



Specification

SPECIFICATION

Part No.	:	A-01
Product Name	:	Hercules Heavy Duty Screw Mount Antenna
Description	:	Two Stage 28dB Height 29mm Diameter 52mm





Specification

1.0 Scope

The A-01 Hercules is a high performance thread mount GPS antenna for external use on vehicles and outdoor assets. Designed for heavy duty work with extra thick threads, there are also convenient side slots for running cables laterally. Durable UV resistant ABS housing is resistant to vandalism and direct attack. At only 29mm high it complies with the latest EU directives for height restrictions, whilst also enabling covert operation with a diameter of 52mm.

2.0 Electrical Specifications

No.	Parameter	Specification
1	Frequency	1575.42MHz±2MHz
2	Dimensions	Height 29mm Diameter 52mm Thread Diameter 18mm
3	Impedance	50 ohm
4	VSWR	2.0 Max
5	Gain	28dB typically Gain at Zenith 5.0dB Gain at 10 o elevation : -1.0 dBi typ
6	Axial ratio	3.0 dB max
7	Polarization	RHCP
8	Noise Figure	1.5 dB max.
9	Operating Temperature	-40°C ~ +85°C
10	Out Band Rejection	fo = 1575.42MHz fo ± 20 MHz 7dB Min. fo ± 30 MHz 12dB Min. fo ± 50 MHz 20dB Min. fo ± 100 MHz 30dB Min.
11	Storage Temperature	-40°C ~ +95°C
12	Cable/Connectors	Standard 2/3/5m RG-174 Cables and Connectors Fully Customisable
13	Housing	UV resistant ABS



Specification

14	Input Voltage	Min:2.5V Max: 5.5V
15	Current Consumption	At 3.0 V Typ: 13mA. Max: 16mA At 5.0 V Typ: 18mA. Max: 22mA

3.0 Drawings

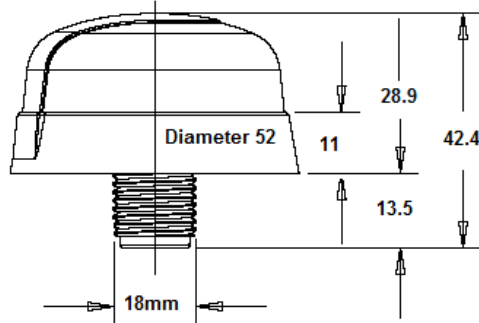
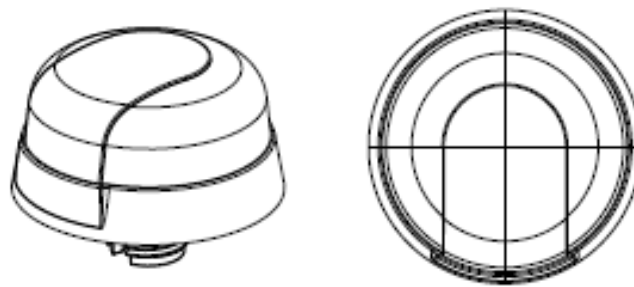

Note: unit cm unless specified

