



Specification

SPECIFICATION

Part No.	:	AA-106
Product Name	:	Titan GPS Antenna AA-106
Features	:	Adhesive Mount – 3M Tape Covert stylish design Wide band input voltage Gain can be adjusted for your application (10dB~31dB) IP-67 Waterproof Custom designed antennas available upon request
Photos	:	





Specification

Electrical Specifications

Centre Frequency	1575.42 MHz ± 2 MHz
Operating Temperature	-30°C to +80°C
Storage Temperature	-40°C to +85°C
Input Voltage	2.7~12V
Power Consumption	5mA Max @14dB 10mA Max@28dB 15mA Max@38dB
Output Connector	Customisable – SMA(M) standard
Mounting	3M Double-Sided Adhesive
Gain	30dB+ Standard – Customizable to 10dB~31dB
Noise figure	1.5dB max
Axial Ratio	2.0dB max
Polarization	RHCP
Output Impedance	50Ω
VSWR	1.92 maximum
Dimensions	44 x 33 x 14 mm

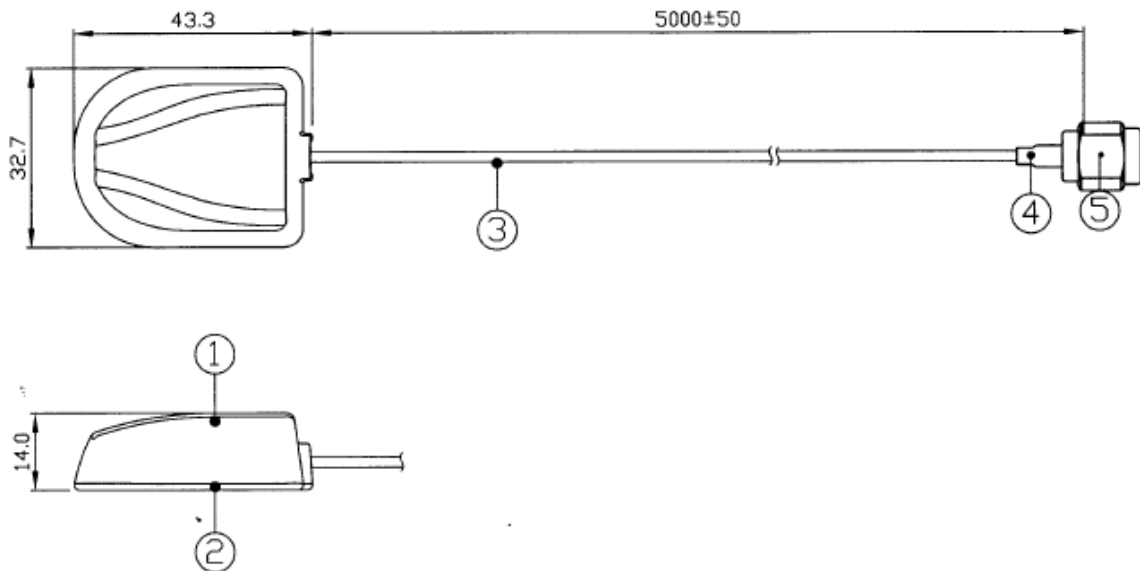

1. GPS Antenna top: PC; Colour: Black
2. GPS Antenna bottom: PC; Colour: Black
3. Cable: RG174
4. Tube: Heat shrink tube
5. Connector: SMA plug standard



Specification

Patch antenna return loss & impedance

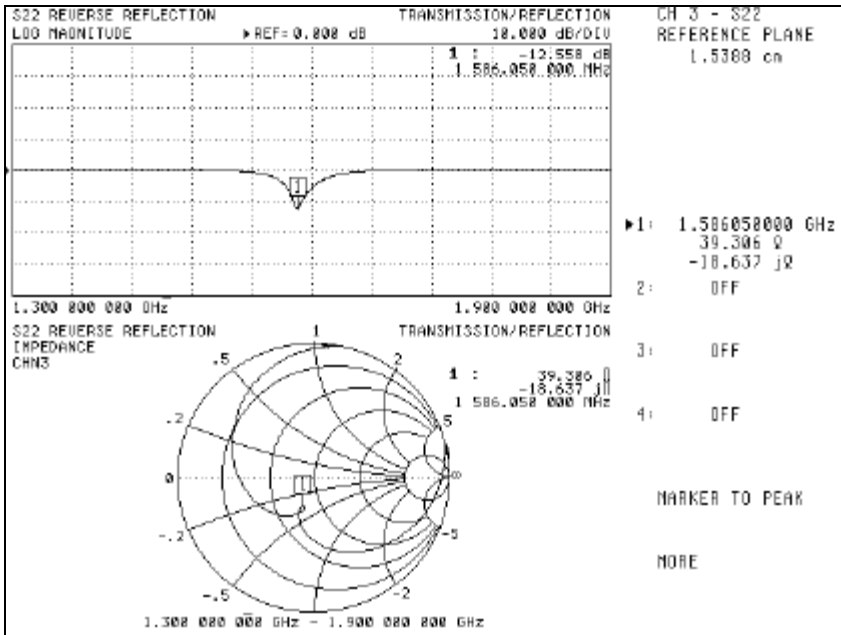

Radiation pattern

