



Specification

1 Scope

This specification covers the dielectric antenna for GPS applications.

2 Name of the product

This product is named “GPS Patch Antenna”.

3 Electrical characteristics

3-1 Electrical characteristics of antenna

The antenna has the electrical characteristics given in Table 1 under the Taoglas standard installation conditions shown in the figure in Appendix

No	Parameter	Specification
1	Center Frequency	1595MHz with 50mm2 GND Plane
2	Bandwidth	8 MHz min (VSWR 2 : 1)
3	VSWR	1.5 max (Center Frequency)
4	Antenna Gain (Toward Zenith)	90° : +2.0 dBi MIN
		20° : -4.5dBi MIN
5	Axial Ratio	90° : 4.0dBi MAX
6	Polarization	RHCP
7	Impedance	50 Ohms
8	Frequency Temperature Coefficient (δf)	0 ± 20ppm / _

Table 1



Specification

4 Environmental conditions

4-1 Operating conditions

The antenna has the electrical characteristics given in Tables 1 in the temperature range of -30°C to $+85^{\circ}\text{C}$ and under the environmental conditions of $+40^{\circ}\text{C}$ 0-95 % r.h.

4-2 Storage temperature range

The storage temperature range of product is -40°C to $+100^{\circ}\text{C}$

5 Reliability tests

5-1. Low-temperature test

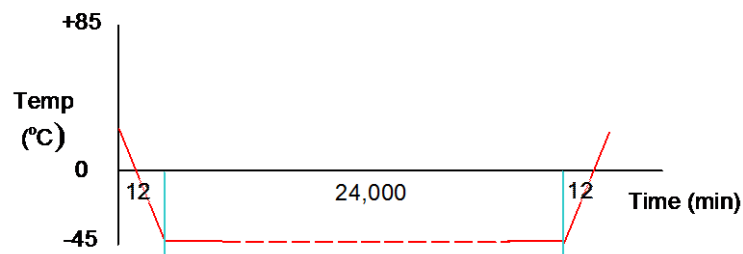

Cooling rate:	5 °C/min
Test temperature:	$-45^{\circ}\text{C} \pm 2^{\circ}\text{C}$
Dwell time	400h
Heating rate:	5 °C/min to room temperature
Settle time:	24h
Pass Criteria:	Gain, bandwidth and centre frequency to remain unchanged after test



Specification

5-2 High-temperature test

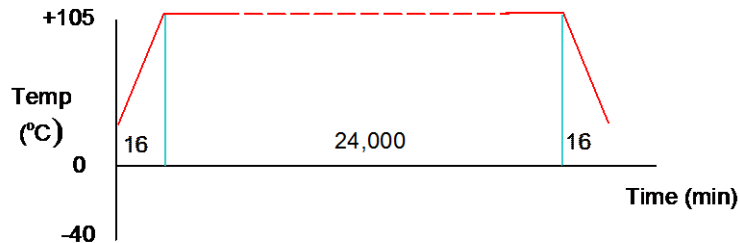

- Heating rate: 5 °C/min
- Test temperature: +105 °C ± 2°C
- Dwell time: 400h
- Cooling rate: 5 °C/min to room temperature
- Settle time: 24h
- Pass Criteria: Gain, bandwidth and centre frequency to remain unchanged after test

5-3 High-temperature/high-humidity test

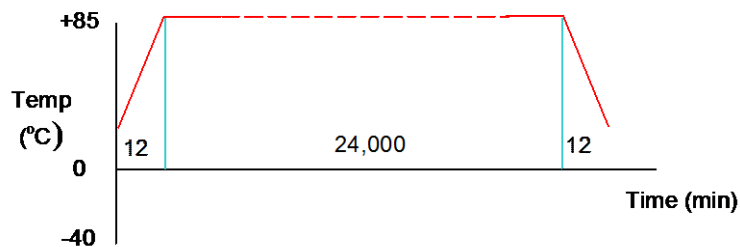

- Heating rate: 5 °C/min
- Test temperature: +85 °C ± 2°C
- Humidity: 90-95 RH
- Dwell time: 400h
- Cooling rate: 5 °C/min to room temperature
- Settle time: 24h
- Pass Criteria: Gain, bandwidth and centre frequency to remain unchanged after test

5-4 Thermal shock test



Specification

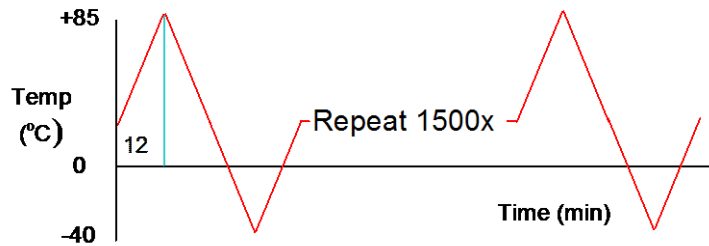

Heating rate: 5 °C/min
Maximum temp: +85 °C ± 2°C
Cooling rate: 5 °C/min
Minimum temp: -40 °C ± 2°C
Pass Criteria: Gain, bandwidth and centre frequency to remain unchanged after test

5-5 Vibration test

5-5-1 Sinusoidal vibration test

Subject the object to vibrations of 5 to 200 to 5Hz swept in 10 minutes, 4.5G at maximum (2mm amplitude), in X and Y directions for two hours each and in Z direction for four hours.

Pass Criteria: Gain, bandwidth and centre frequency to remain unchanged after test

5-5-2 Vibration test in packaged condition

Subject the object, which is packaged as illustrated, to vibrations of 15 to 60 to 15Hz swept in 6 minutes, 4G at maximum (2mm amplitude at maximum), applied in X, Y and Z directions for two hours each.

Pass Criteria: Gain, bandwidth and centre frequency to remain unchanged after test

5-6 Free fall test in packaged condition



Specification

Drop the object, which is packaged as illustrated, to a concrete surface from the height of 90 cm, on one corner, three edges and six faces once each, i.e. 10 times in total.

Pass Criteria: Gain, bandwidth and centre frequency to remain unchanged after test

6 Inspection

Inspection is done in mass production, the receiving character of the ratio wave sent in a shield box from the standard antenna and VSWR are confirmed by sampling inspection.

7 Test Record

A copy of the test record filled with the following contents shall be provided at time of delivery.

7-1 Quantity of delivery

7-2 Measurement of electrical characteristics :

following data at normal temperature obtained by the method described in section 8.

Overall Gain (toward zenith)

Output VSWR

7-3 Temperature and humidity of test

Quantity for sampling inspection shall be $n=5$ for any lot. In case quantity per lot is less than 5, the whole lot shall be inspected.

8 Warranty

If any defect occurs with the product during normal use within a year of delivery, it will be repaired or replaced free of charge.

9 Other

Any question arising from this specification manual shall be solved by arrangement made by both parties.



Specification

10 Precautions for use

A silver electrode is used for the antenna pattern.

Please refrain from use of corrosive elements (sulfur gas, chlorine gas) in the atmosphere.

Please don't direct solder onto the silver electrode antenna pattern.



Specification

Appendix:

Performance Measurement

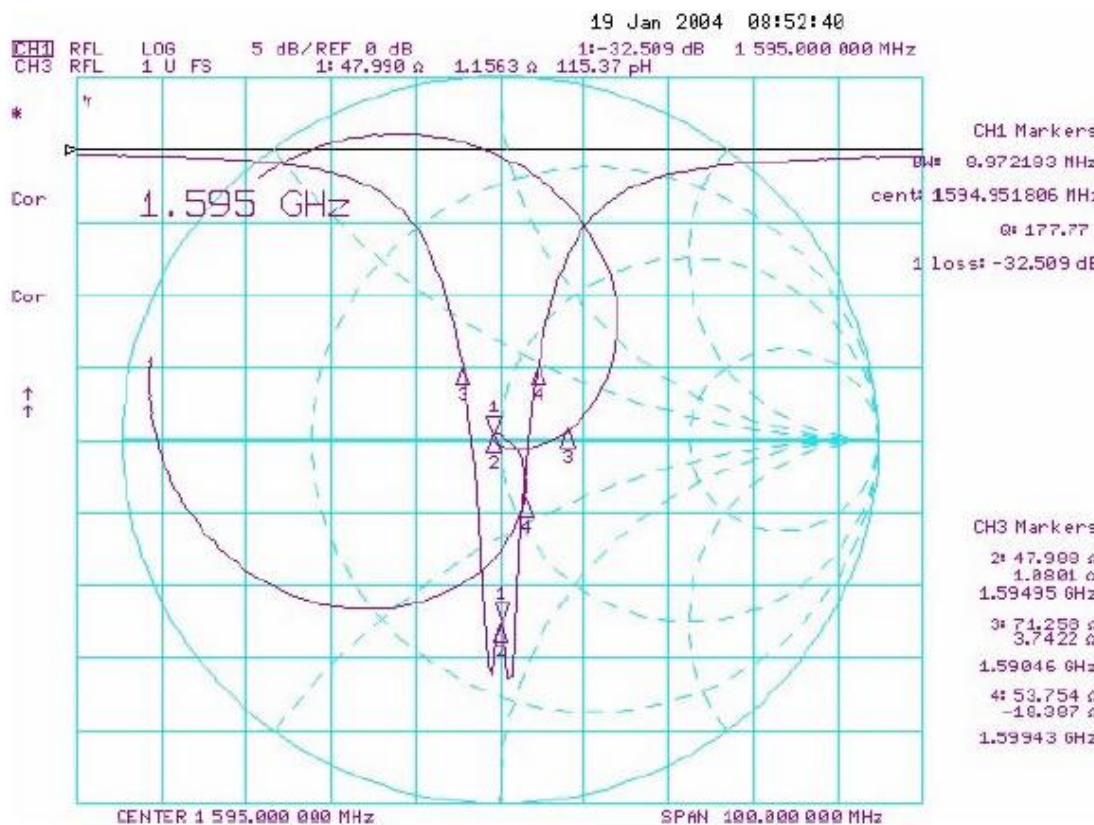



Specification

Normalized Antenna Gain Chart

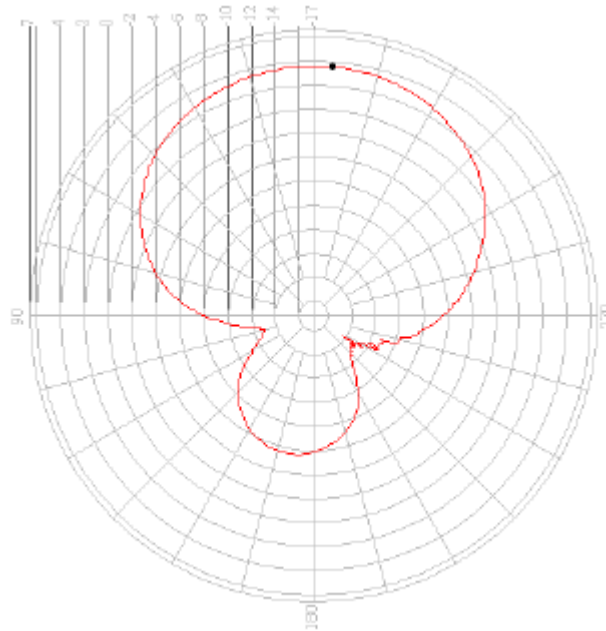



Specification

Shape and Dimension

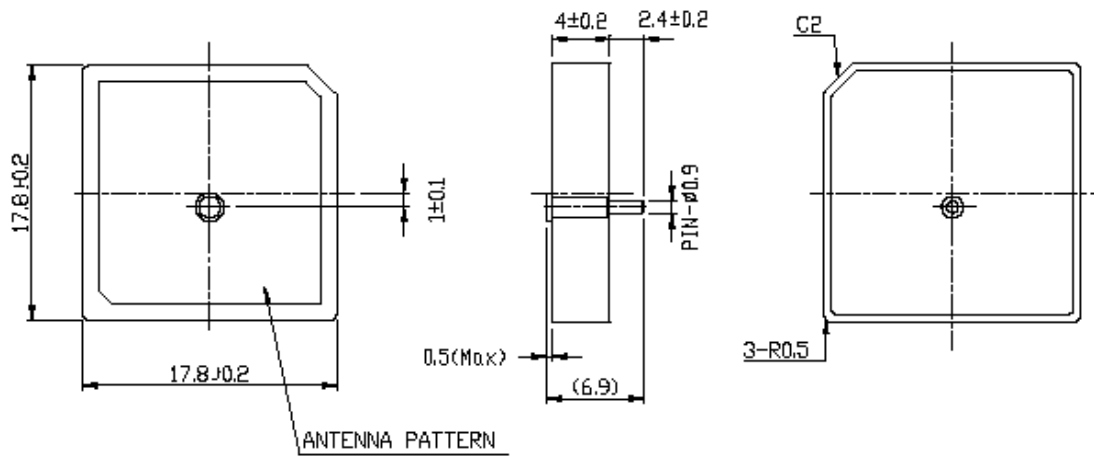

Tape Dimension



Specification

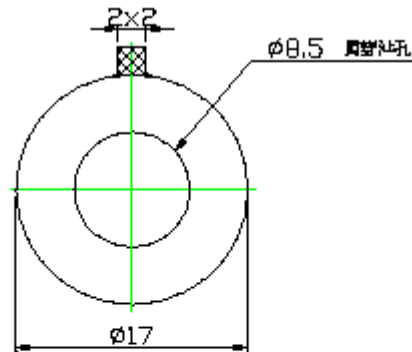

- 備註: 1.NITTO :NO.5015
- 2.Double-coated adhesive tape for industrial use
- 3.Thickness :0.12mm

Test Jig and Dimension

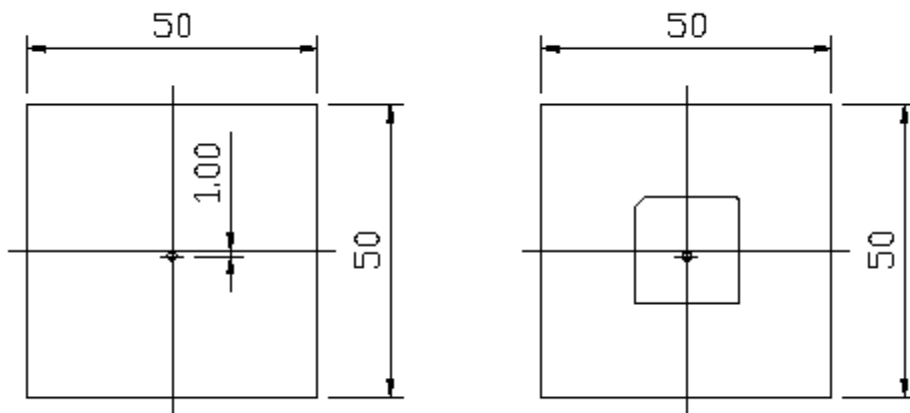

Test Fixture Antenna Setup & Measurements



Specification

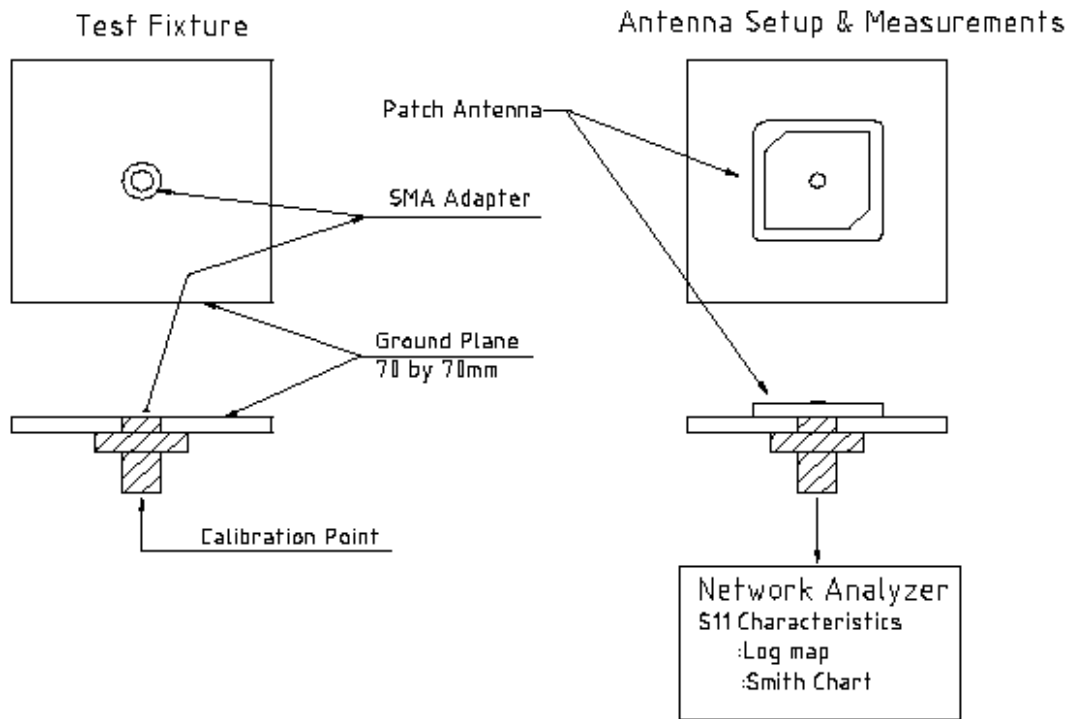

Mark

