



Specification

# SPECIFICATION

Part No. : **PA-03**  
Specification No : PA-1575-00-14-A-02  
Product Name : Dielectric PIFA Antenna for GPS  
Description : 1575Mhz, 0dB Gain  
Size: 14mm\*6mm\*5mm



## REVISION STATUS

Version	Date	Page	Revision Description	Prepared	Approved
01	January 19th 2006	All	New format	TW Product Centre	Ronan Quinlan



**Specification**

**1.0 Scope**

This specification is a miniature PIFA (Dielectric Planar Inverted-F Type Antenna) Antenna for mobile GPS applications.

**2.0 Electrical Specifications**

The antenna has the electrical characteristics given in Table 1 under the Taoglas standard installation conditions as shown in the Evaluation Board.figure.

No.	Parameter	Specification
1	Frequency	1575.42MHz±1.023MHz
2	Dimensions	14*6*4.8 mm
3	Impedance	50 Ohms-
4	VSWR	2.5 Max
5	Peak Gain	0 dBic typically
6	Average Gain	-6.5 dBic typically
7	Polarization	Linear
8	Termination	Ag (ROHS Compliant)
8	Weight	0.5g
9	External Matching Circuit	None
10	Mode	$\lambda / 4$
11	Mounting	SMT

\*Data is measured on Taoglas Standard Reference PCB. (40\*80\*8.0mm)



Specification

Reflection Characteristics

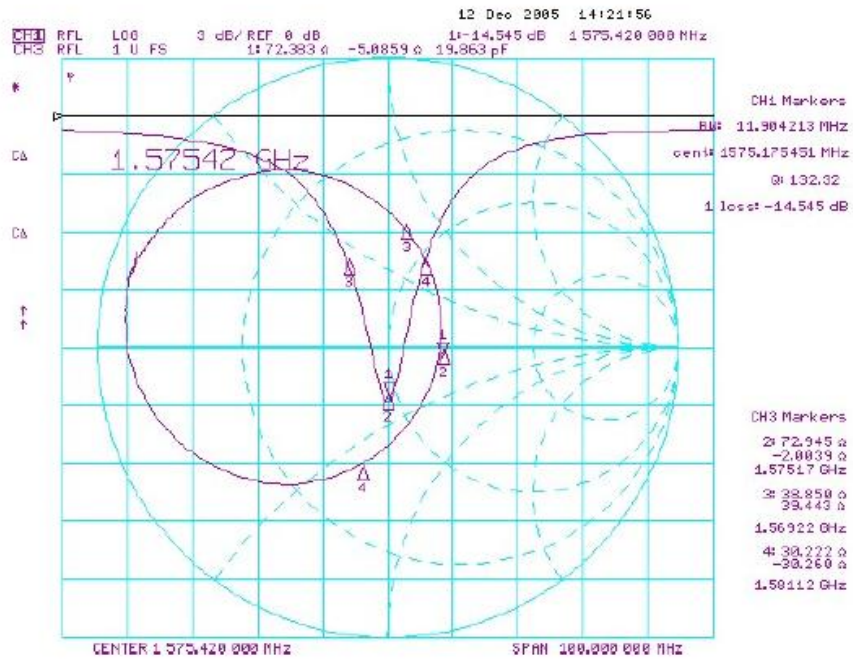

Horizontal Orientation Shown

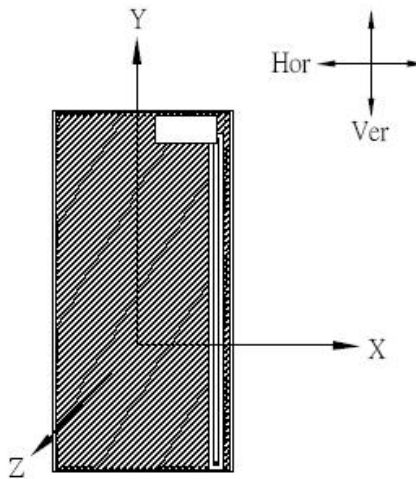



## Specification

### 3.0 Environmental Conditions

#### 3.1 Operating Conditions

The antenna has the electrical characteristics given in Table 1 in the temperature range of -30°C to +825°C and under the environmental conditions of +40 and 0-95%r.h.

#### 3.2 Storage Temperature range

The storage temperature range of the product is -40°C to +100°C

### 4.0 Reliability Tests

#### 4.1 Low-temperature test

Expose the specimen to -30°C for 500 hours and then to normal temperature/humidity for 24 hours or more. After that examine the appearance and functions.

#### 4.2 High-temperature test

Expose the specimen to +85°C for 500 hours and then to normal temperature/humidity for 24 hours or more. After that examine the appearance and functions.

#### 4.3 High-temperature/High-humidity test

Subject the object to the environmental conditions of +85°C and 90-95% r.h. for 96 hours, then expose to normal temperature/humidity for 24 hours or more. After this, check the appearance and functions.

#### 4.4 Thermal Shock test

Subject the object to cyclic temperature change (-30°C, 30 minutes +85°C, 30 minutes ) for 5 cycles, the expose to normal temperature/humidity for 24 hours or more.

#### 4.5 Vibration Test

##### 4.5.1 Sinusoidal Vibration Test

Subject the object to vibrations of 5 to 200 to 5Hz swept in 10 minutes, 4.5G at maximum (2mm amplitude), in X and Y directions for two hours each and in Z direction for four hours. After this, check the appearance functions.

##### 4.5.2 Vibration test in packaged condition

Subject the object, which is packaged as illustrated, to vibrations of 15 to 60 to 15Hz swept in 6 minutes, 4G at maximum (2mm



## Specification

amplitude at maximum), applied in X, Y and Z directions for two hours each, i.e. six hours in total. After this, check the appearance and functions.

### 4.5.3 Free fall test in packaged condition

Drop the object, which is packaged as illustrated, to a concrete surface from the height of 90 cm, on one corner, three edges and six faces once each, i.e. 10 times in total. After this, check the appearance and functions.

### 4.5.4 Soldering Heat Resistance Test

The lead pins of the unit are soaked in solder bath at  $270 \pm 5^\circ\text{C}$  for  $10 \pm 0.5$  seconds and then left for more than 1 hour at  $25 \pm 5^\circ\text{C}$  in less than 65% relative humidity.

### 4.5.5 Adhesion Test

The device is directly soldered on test PCB. Then apply 0.5Kg (5N) of force for  $10 \pm 1$  seconds in a parallel direction to the substrate. (Note: the soldering should be done by reflow and conducted with care so that the soldering is uniform and free of defect by stress such as heat shock).

## 5.0 Inspection

Under mass production examination, the reception characteristic of the ratio wave sent in a shield box from the standard antenna and VSWR are confirmed by sampling.

## 6.0 Warranty

If any product defect occurs during normal use within a year after delivery, it will be repaired or replaced free of charge.

## 7.0 Other

Any questions arising from this specification manual shall be solved by arrangement made between both parties.

## 8.0 Precautions for Use

**8.1** The antenna pattern uses silver electrode.

**8.2** Avoid contact with corrosive gases (sulfur gas, chlorine gas) in the atmosphere.

**8.3** Do not directly solder onto the gold electrode of the antenna pattern.



Specification

9.0 Drawings

9.1 Outline Dimensions

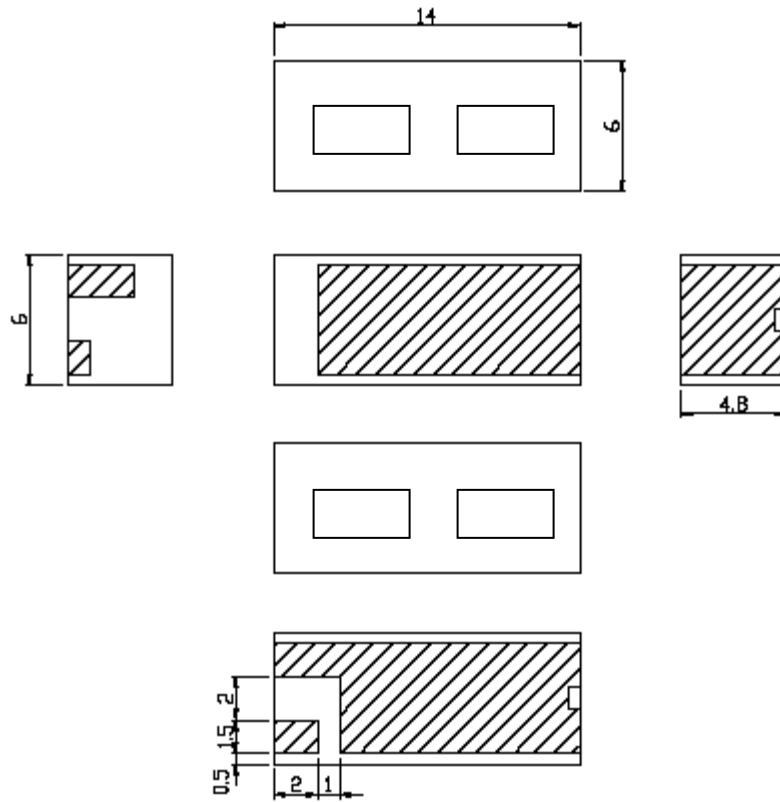

9.2 Recommended Footprint for Evaluation Board

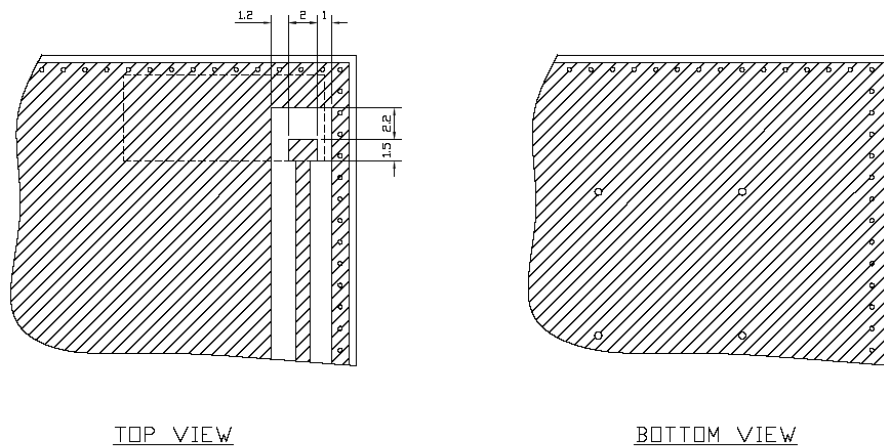

TOP VIEW

BOTTOM VIEW