

**APPLICATION NOTE  
FOR  
PA.22A ANTENNA INTEGRATION**



## I. BASICS

The PA.22A Planar Inverted F Antenna (PIFA) consists of a rectangular planar element located above a ground plane, a short circuiting plate, and a feeding mechanism for the planar element. The product is SMD process compatible and delivered in tape and reel, making a unique highest performance and practical solution for current market needs.

The PIFA is a variant of the monopole where the top section has been folded down so as to be parallel with the ground plane. This is done to reduce the height of the antenna, while maintaining a resonant trace length. This parallel section introduces capacitance to the input impedance of the antenna, which is compensated by implementing a short-circuit stub. The stub's end is connected to the ground plane via the short circuiting plate on the edge of the antenna, whose function is to extend the bandwidth of the PIFA.

The ground plane of the antenna plays a significant role in its operation. Excitation of currents in the PIFA causes excitation of currents in the ground plane. The resulting electromagnetic field is formed by the interaction of the PIFA and an 'image' of itself below the ground plane.

Its behaviour as a perfect energy reflector is consistent only when the ground plane is infinite or very much larger in its dimensions than the monopole itself. In practice the ground-plane area is of comparable dimensions to the monopole and forms the 'image antenna' which is one half of the dipole.

The antenna/ground-plane combination will behave as an asymmetric dipole, the differences in current distribution on the two-dipole arms being responsible for some distortion of the radiation pattern.

## II. GROUND PLANE SIZE

In general, the required PCB ground plane length should be at least one quarter ( $\lambda/4$ ) of the operating wavelength.

- If the ground plane is much longer than  $\lambda/4$ , the radiation patterns will become increasingly 'multilobed'.
- On the other hand, if the ground plane is significantly smaller than  $\lambda/4$ , then tuning becomes increasingly difficult and the overall performance degrades.
- The optimum location of the PIFA in order to achieve an Omni-directional far-field pattern and 50 $\Omega$  impedance match was found to be close to the edge of the Printed Circuit Board.

### III. BANDWIDTH

The bandwidth of the PA.22A is affected considerably by the size of the ground plane. By varying the size of the ground plane, the bandwidth of a PIFA can be adjusted. For example, a reduction of the ground plane area can effectively broaden the bandwidth of the antenna system. An increase in the bandwidth of the PIFA (and thus a reduced quality or Q-factor), can be achieved by inserting several slits at the ground plane edge, however this is not always practical in real life systems.

### IV. GAIN

The gain of the PA-22 will be affected by the area of the ground-plane. As explained in section 1, the ground-plane of a PIFA is electrically one half of the dipole (known as the image antenna) and thus a larger ground-plane will yield an improved gain.

### V. ADVANTAGES

- Compact volume, minimum footprint - It can be placed into the housing of the mobile/handheld device, unlike most whip/rod/helix antennas.
- Achieves moderate to high gain in both vertical and horizontal polarization planes. This feature is very useful in certain wireless communications where the antenna orientation is not fixed and the reflections or multipath signals may be present from any plane. In those cases the important parameter to be considered is the total field strength that is the vector sum of the signal from the horizontal and vertical polarization planes at any instant in time.
- Labor saving SMT – also ensures higher quality yield rate
- No antenna tooling cost for customer
- Robust single block structure

## VI. MOUNTING

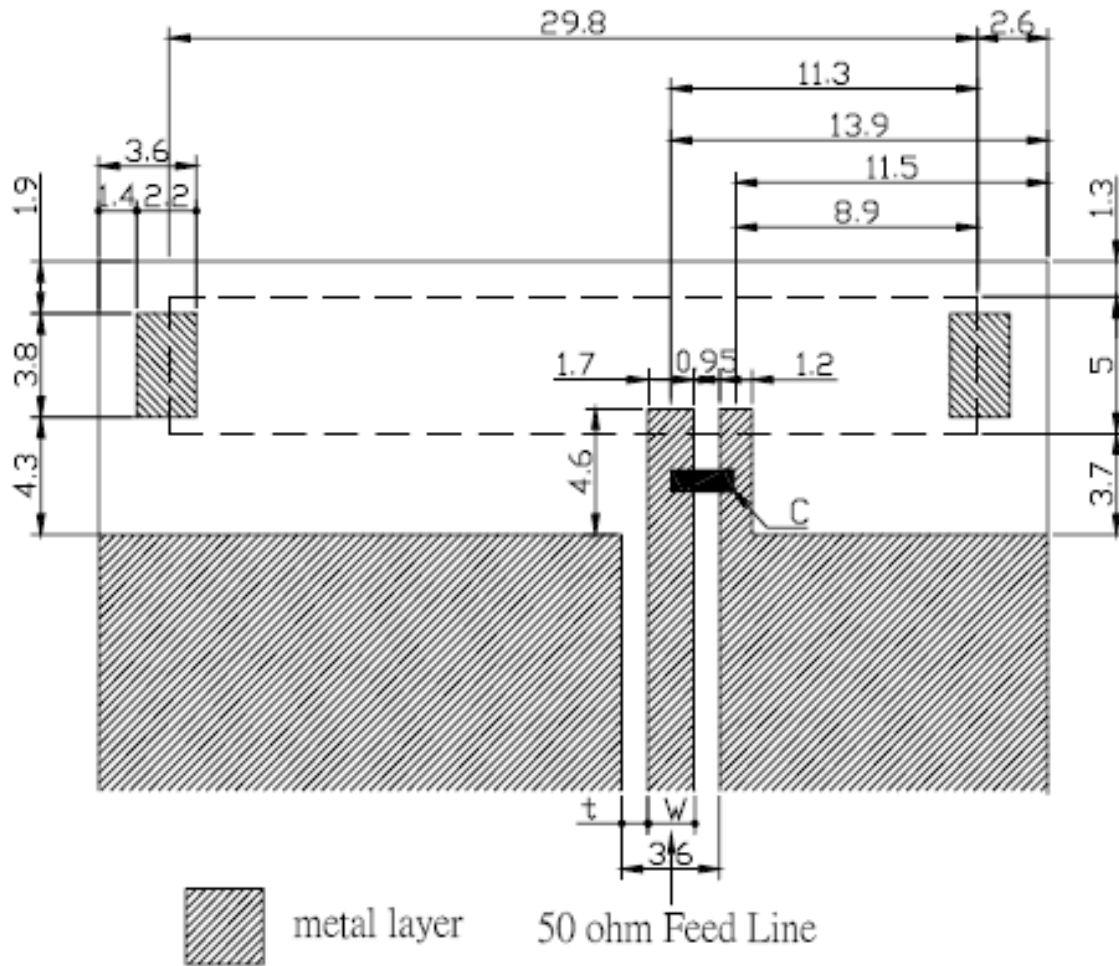

$t, w$  = Unique dimensioning according to your PCB.  
 $C$  = inductor and capacitor values according to your specific device.

Mount on non-conductive area close to ground-plane ensuring minimum separation distances are obeyed.

Best results are achievable when placed close to the edge of the board, see the outline drawing in the specification.

## VII. ENVIRONMENTAL CONSIDERATIONS

Close proximity to components or housing affects the electrical performance of all antennas. When placed on a non-conductive area of the board, ideally there should be clearance of 4mm in all directions from the board/housing for maximum efficiency. A reduction in the efficiency of the antenna efficiency or a slight shift in tuned frequency will be observed if these clearances are not adhered to. Proximity effects will also have an adverse effect on the radiation pattern of the antenna.

## VIII. TUNING

PIFA antennas are less susceptible to detuning from the close environment than other antennas due to their design. However tuning optimization can be carried out by;

### 1. Appropriate Choice of Matching Circuit

If the customer can give the housing and reference PCB to Taoglas then Taoglas can carry out the necessary S11 response measurements in both magnitude and Smith Chart format of the complete system. The necessary impedance matching circuit should be designed on the customer side if he/she has access to a software modeling tool which simulates the system. The matching circuit values obtained from this exercise can then be employed and adjusted via trial and error to obtain the optimal 50 Ohm match at the frequencies of interest. It should be noted that the impedance matching can improve the response of the antenna at certain frequencies (or bands of frequencies in the case of wideband matching circuits) but a reduction in the response at other frequencies may be observed.

### 2. Inductor

On the Taoglas evaluation board it was found that either a 4.7nH or 6.8nH grade chip inductor can be used to obtain a 50 Ohm impedance match across the frequency bands.

### 3. Other Techniques for Tuning

#### Lower Frequency

- A. Lengthen distance of PIFA to ground
- B. Cutting a bridged meander line on side of antenna will lengthen wavelength and reduce frequency. Would need to be implemented on manufacturing side.
- C. Larger surface area on contact pad will lengthen effective wavelength and reduce frequency

#### Higher Frequency

- A. New photomask would be needed on manufacturing side. But this is a very expensive process so we designed the antenna so that in practice the antenna should not need to be tuned to higher frequency.