

# APPLICATION NOTE FOR PA.700A ANTENNA INTEGRATION

VERSION A



## I. TABLE OF CONTENTS

I. TABLE OF CONTENTS	2
II. BASICS	3
III. APPLICATIONS	3
IV. IMPEDANCE	4
V. BANDWIDTH	4
VI. GAIN	4
VII. POLARIZATION	5
VIII. EFFICIENCY	5
IX. GROUND PLANE EFFECTS	6
X. ISOLATION	7
XI. ELECTROMAGNETIC ENVIRONMENT	8
XII. ADVANTAGES	8
XIII. DESIGNING THE CPW	9
XIV. MATCHING DESIGN	12
XV. MOUNTING	15
XVI. MAJOR NO NO's	16

## II. BASICS

PA.700A is a Monopole-PIFA SMD antenna. Knowledge and design of the best environment to use such an antenna is crucial to optimizing its performance and thus the RF device performance itself.

The PA.700A Planar Inverted F Antenna (PIFA) is without ground plane behind the antenna structure, with rectangular planar elements located in a ceramic substrate, with a short circuiting plate and a feeding mechanism. The product is SMD and delivered in tape and reel, making a unique high performance and practical solution for current market needs.

PA.700A PIFA antenna couples to the ground to achieve high radiation performance. The size of the ground plane plays an important role in the antenna efficiency and is related to the wavelength, having more effect at low frequencies. The optimal size for a ground plane is 107 x 45 mm, as the evaluation board. However the antenna can be used for smaller ground-planes with very good results compared to any other existing antenna technology.

This design application note is intended for the antenna integrator to understand the relevant parameters affecting the antenna performance. Taoglas recommends that the integrator strictly follow the guidelines in this application note, upon your device prototype completion Taoglas offers further optimization by custom tuning and testing service of the antenna in your device, and assists you in the design process not just from the antenna perspective but also in achieving an ideal electromagnetic environment.

## III. APPLICATIONS

The PA.700A is an extension version of PA.25 that works from 700MHz to cover LTE bands. It is suitable for all remote side cellular applications, such as GSM, AMPS, GPRS, CDMA, WCDMA, UMTS, HSPA and LTE etc.

This antenna is SMT mounted and a section on the shorter edge of the device main board need to be metal free for PA.700A to radiate well.

## IV. IMPEDANCE

RF circuits in mobile devices should be designed for 50 Ohm impedance at the source (RF module), transmission line (PCB trace or co-axial cable) and load (antenna). In practice, sometimes the characteristic impedance of the circuit is not exactly 50 Ohms at different transmitting and receiving bands. The antenna impedance needs to be adjusted to match the actual characteristic impedance of the circuit. For a cellular antenna this is most effective when tuning the antenna at the over the air active testing stage in a 3D radiation chamber, when the device is turned on and using the TRP and TIS numbers as guide to find the best impedance match for the antenna.

## V. BANDWIDTH

We normally target a minimum of -5dB return loss at the band edge and -10dB peak for LTE antenna in small mobile device. The ground plane size and antenna surrounding /clearance define the return loss of PA.700A.

We have designed PA.700A on a target board with 107mm long ground and 13mm metal free part to meet the bandwidth requirement for LTE. PA.700A works well for PCB with ground length of over 70mm. We also recommend a minimum clearance from metal parts, including PCB ground, of 5mm. Antenna performance would be degraded if the clearance is less than the recommended 5mm.

## VI. GAIN

The gain of the antenna is closely linked to the effective surface area or volume of the antenna. The larger the surface area or volume of the antenna, the higher the gain that can be obtained; the ideal target for gain for a cellular band antenna in a mobile device which needs omni-directional radiation characteristics is peak gain of 0 dBi. Higher gain means the radiation is higher in certain directions and other directions are reduced. The use of ceramic materials can achieve high efficiencies in small form factors.

## VII. POLARIZATION

Polarization describes the orientation of the wave oscillation. All our cellular and broadband antennas are linearly polarized, to most efficiently match with the signals broadcast and the antennas mounted on cellular base-stations.

Whether it is horizontally or vertically polarized depends on how it is mounted from your frame of reference. The polarization of PA.700A is along the longer side of the antenna. In practice the radiation emitted and received by internal antennas would have certain cross-polarization due to reflections from the environment and scattering in the atmosphere.

## VIII. EFFICIENCY

Efficiency is defined as the percentage of the power radiated out from the antenna for a given input. Since mobile or portable device is ideally to have isotropic radiation with 0 gain, efficiency is a good indication of antenna radiation performance.

In general 20% efficiency or higher at all bands is good enough for worldwide mobile use. However it is recommended to aim for 40%+ in efficiency if the device needs to pass operator approvals after PTCRB in the US, especially where AT&T approval is required. In this case a ground-plane length of 70mm or above should be used where possible. Shorter ground-plane lengths may still pass approvals but with less certainty. Higher efficiency also translates into better device performance in weak signal areas and lower battery consumption.

Efficiency of the antenna directly relates to the TRP/TIS results of a device in OTA testing if the module has 50 Ohm impedance. However this is only one factor and care must be taken to not single out antenna efficiency as the only reason why a device does not meet certain TRP/TIS targets. Impedance mismatches, conducted power from the module and noise can sometimes have a greater effect on TRP/TIS than the antenna efficiency.

## IX. GROUND PLANE EFFECTS

In general for a PIFA, the required PCB ground plane length should be at least one quarter ( $\lambda/4$ ) wavelength of the lowest operating band.

If the ground plane is much smaller than  $\lambda/4$  of the lower bands, will affect the efficiency of the antenna, this mean the having problem to radiate the energy.

If the ground plane is much longer than  $\lambda/4$  of the lower bands, will affect the high frequency, this is easily observed in the efficiency graph provided for different ground plane lengths as next.

For those devices where the length of the ground plane is larger than the optimal (107mm), can be compensated increasing the width of the ground plane. There is no specific proportion to do this, but we can study case by case depending on your board size.

For those devices where the length of the board is less than 70 mm, there is little to do to improve the antenna performance.

The PIFA antenna must be strictly allocated in one of the shorter sides of the your board, the electromagnetic waves travel parallel to the longest side of the board, having the perfect condition to radiate the energy, not following this recommendation will degrade the antenna performance drastically. A larger ground-plane improves return loss and efficiency, but having the max-optimal length at 107 mm (without area for the antenna), when the width is 45 mm and a minimal recommended of 70 mm for high efficiency applications.

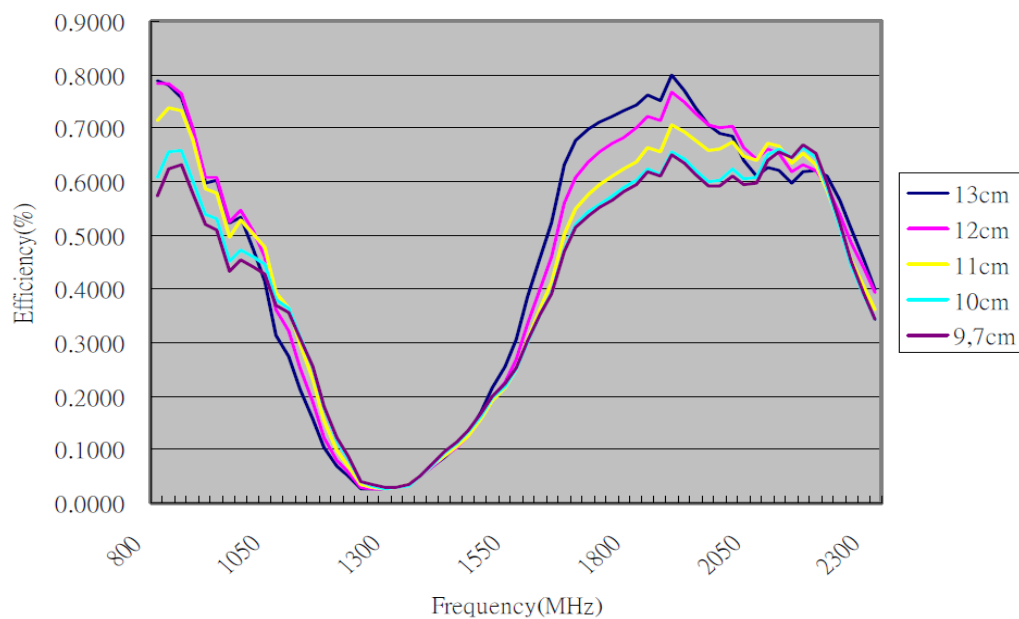

**Figure 1.** Efficiency at different ground plane lengths.

The top PCB layer ground has the dominate effect to the antenna performance compare with ground in other PCB layer. RF theory does not follow the traditional AC/DC laws; here is where Maxwell shifts Kirchhoff. It's important that you must fill the PCB with ground as much you can on the top and bottom layer, having several via holds to interconnect the ground plane in all layers (top, bottom and middle layers). Also it's important for the Co-Planar Waveguide (CPW) transmission line discussed later.

On the top and bottom layers of main board, can be allocated as much components as needed, but trying to fill all the left area with ground plane having continuity along the 2 layers. For those places where the ground plane cannot be continued, insert via holes to interconnect with the middle layer ground plane and/or the ground plane at the bottom layer.

## **X. ISOLATION**

Isolation is a measure of coupling between two different antennas. In general care should be taken to ensure isolation between all antennas in a device. The easiest and most effective method is to place them as far away from each other as possible.

For example, in a CDMA diversity antenna plan the target is to get -10dB isolation between the main and the auxiliary antenna. Greater isolation can be achieved by using different polarizations on the two antennas. For example the main antenna can be positioned horizontally and the auxiliary antenna vertically. In practice this is difficult for omni-directional internal cellular antennas as there is cross-polarization of the waves occurring. So the normal solution is to keep the distance from both antennas as far away as possible.

Testing is carried by sending a signal to one antenna and measuring the power of the signal at the other antenna, using the S21 on network analyzer. There should be a 10dB or greater difference between the transmitted and the received signal. One way to achieve adequate isolation is to move the two antennas farther from each other until reaching target isolation.

## **XI. ELECTROMAGNETIC ENVIRONMENT**

Close proximity to components or housing affects the electrical performance of all antennas. When placed on a non-conductive area of the board, there should be clearance of 5mm in all directions from metal components for maximum efficiency. A reduction in the efficiency of the antenna and a shift in tuned frequency will be observed if these clearances are not followed. Proximity effects will also have an adverse effect on the radiation pattern of the antenna. Device housings should never be metal, polycarbonate and/or coated with EMI absorption material. For the PA.700A we recommend at least 3mm of clearance from enclosure for best performance. Below 1mm will cause major issues, such antenna detuning and low radiation efficiency.

## **XII. ADVANTAGES**

- Compact volume, minimum footprint - It can be placed into the housing of the mobile device, unlike most whip/rod/helix antennas.
- It can be machine surface mounted directly on edge of device main-board.
- Transmission losses are kept to absolute minimum resulting in much improved over the air (OTA) device performance compared to similar efficiency cable and connector antenna solutions
- Reductions in probability of radiated spurious emissions compared to other antenna technologies are observed when using the PA.700A and strictly following this application note layout
- Achieves moderate to high gain in both vertical and horizontal polarization planes. This feature is very useful in certain wireless communications where the antenna orientation is not fixed and the reflections or multipath signals may be present from any plane. In those cases the important parameter to be considered is the total field strength, which is the vector sum of all signals from the horizontal and vertical polarization planes at any instant in time.
- Labour saving SMT – also ensures higher quality yield rate
- No antenna tooling cost for customer.

### XIII. DESIGNING THE CPW

The CPW (Co-Planar Waveguide) design is only from the GSM Module to the edge of the ground plane. Beyond the edge of the ground plane to the antenna is not a CPW, this is a special interconnection line. Depending on the thickness and number of layers of the board, the CPW can be adjusted to maintain a 50 Ohms +/- 10% system.

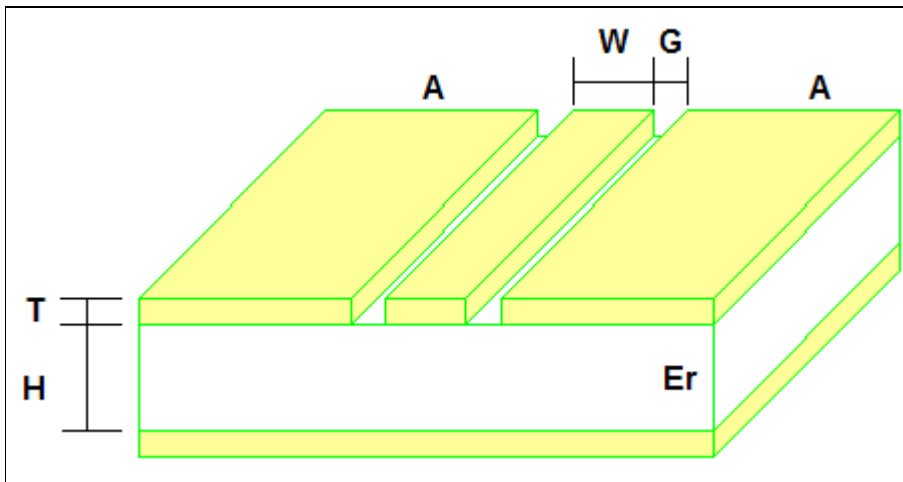

**Figure 2.** Representation of Co-Planar Waveguide (CPW).

Inputs:

Width=1.2 mm (W)

Gap=0.5 mm (G)

Thickness=0.36 mm (T)

Height=0.76 mm (H)

Dielectric Constant=4.4 (Er)

Conductivity= $5.88 \times 10^7$  S/m

Loss Tangent=0.02

Frequency=2170 MHz

Outputs:

Impedance=50.02 Ohms

Loss=1.51 dB/m

The CPW can be adjusted for Gap, Width and Height. The Gap and Width we recommend

changing the values but not too far away from those proposed here, so as to avoid abrupt changes in different widths and separations. The CPW can be designed in between the TOP and BOTTOM Layers or in between the TOP and GND Middle Layers.

Depending on the selected pair chosen, the height can be changed to obtain a 50 ohms system depending on each individual project need. In between the pair chosen must be free of other layers, traces, etc, having a cutout where the CPW path is designed.

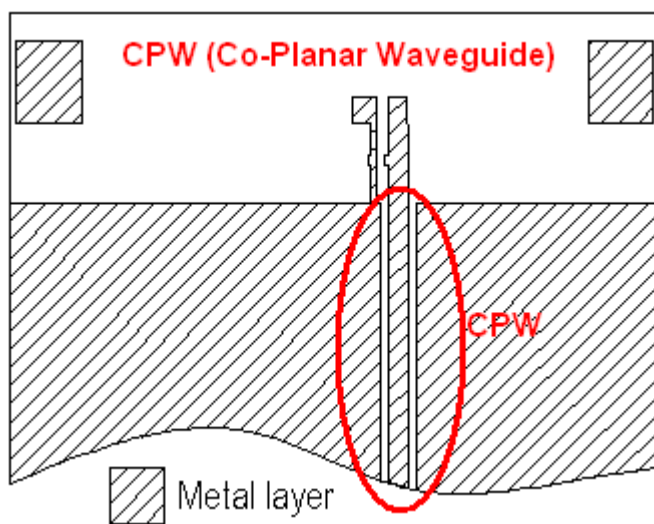

**Figure 3.** Co-Planar Waveguide (CPW).

## Tips in designing CPW

We recommend incorporating in the design via holes at the edge of the ground plane aside of the center signal trace from the CPW. This will help to ensure grounds on all layers are well connected to each other and have the same voltage level, thus keeping the 50 ohms system reliable and a proper RF ground plane for the antenna.

Making a fence around the board with via holes will result in a better shielding of the system, providing more resistance against noise issues, better ground and optimum antenna performance. This via hole fence must interconnect the ground planes in between (TOP, BOTTOM and GND Layers), plus some random via holes on the entire board. The next figure shows via holes around the CPW and fencing the board.

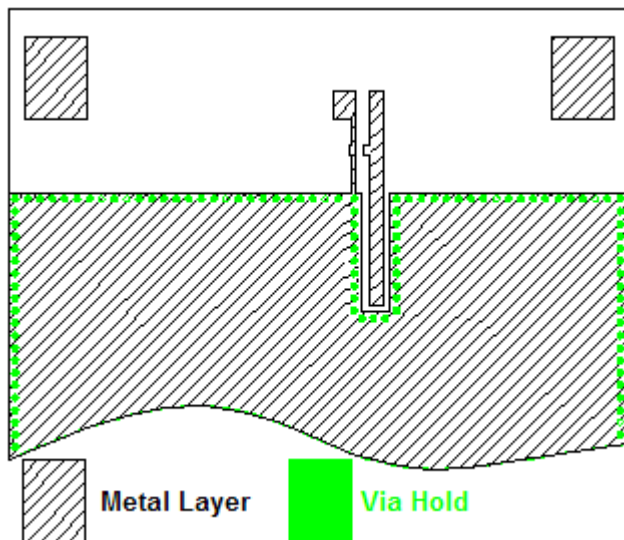

Figure 4. Via holes fence.

## XIV. MATCHING DESIGN

PIFA antennas are less susceptible to detuning from the close environment than other antennas. But sometimes having the proper matching circuit can improve the antenna performance. PA.700A needs a 8.2nH (L1 in Figure 5) inductor in parallel to have 50ohms impedance. We recommend to have a pi network pre-allocated during PCB layout in case matching circuit is used later.

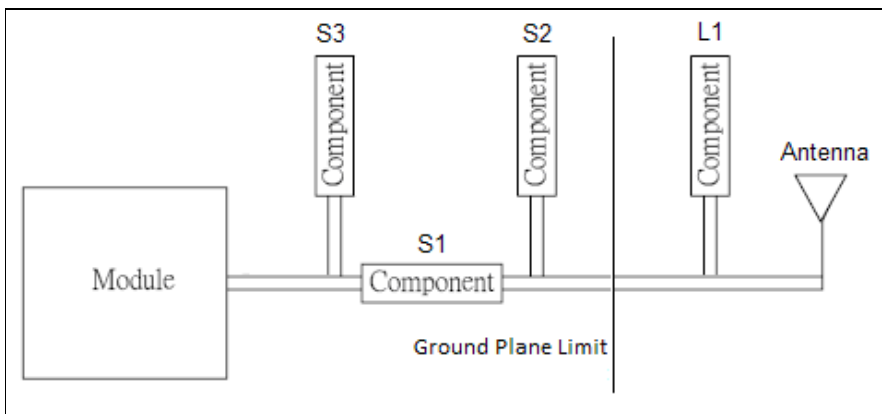

Figure 5. Matching circuit.

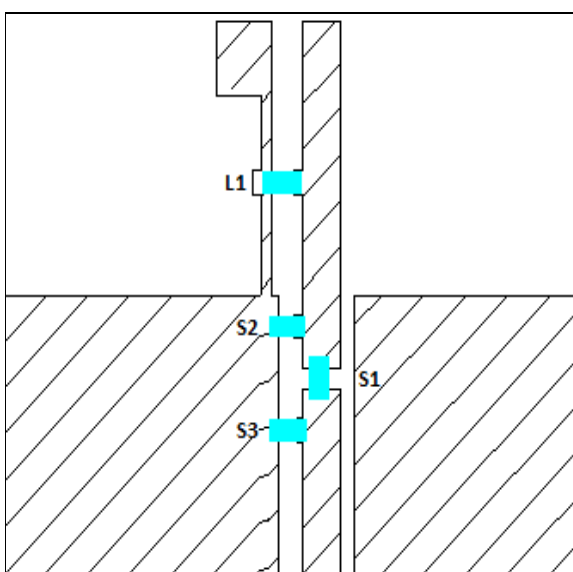
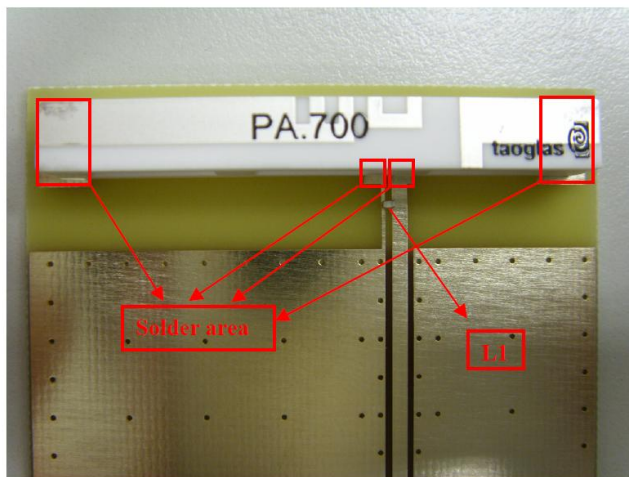
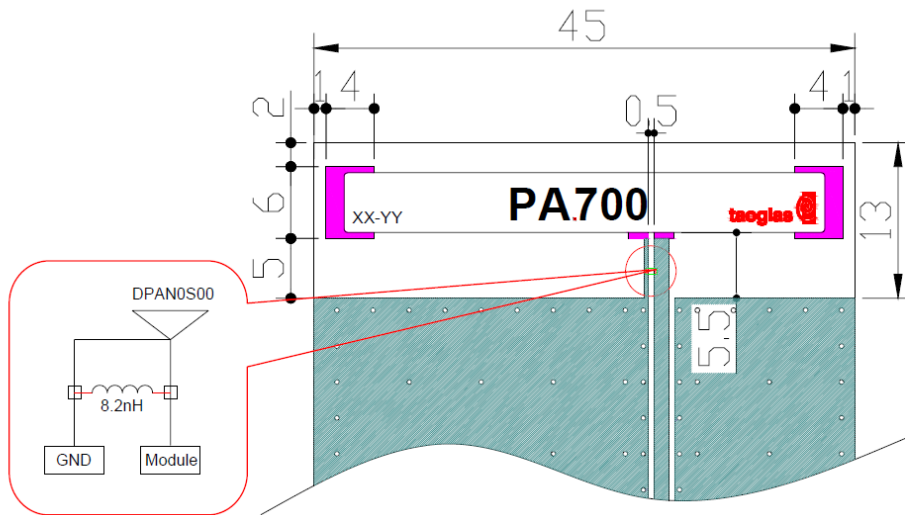

Figure 6. Layout for the Matching circuit.

## Matching Circuit on EVB



Circuit Symbol	Size	Description
L1	0402	8.2nH Inductor (MLK1005S8N2D)

## Mandatory Outside inductor

The PA.25 needs a lumped component at the antenna to obtain a 50 Ohm impedance match across the frequency bands. We recommend starting with a 2.2 nH for short ground planes (45-75 mm) and 6.8 nH for larger ground planes (80-100 mm).

## **Appropriate choice of matching circuit**

Taoglas offers RF integration services. If the customer uses our service they can give the housing and reference PCB to Taoglas then Taoglas can carry out the necessary S11 response measurements in both magnitude and Smith Chart format of the complete system. The necessary impedance matching circuit should be designed on the customer side if he/she has access to a software modeling tool which simulates the system.

The matching circuit values obtained from this exercise can then be employed and adjusted via measurement and simulation to obtain the optimal 50 Ohm match at the frequencies of interest, establishing the type and values for the lumped components. It should be noted that impedance matching can improve the response of the antenna at certain frequencies (or bands of frequencies in the case of wideband matching circuits) but a reduction in the response at other frequencies may be observed.

The “pi” network can have inductors or capacitor combinations, any board will have a very different effect over the antenna return loss, we can not give the values for this “pi” network and in some cases it is not needed at all.

## **Starting values for the PI network**

Leave a zero Ohm resistor in series in the “pi” matching network (S1) and no lumped components in parallel (S2 and S3). Further optimization could be done as part of a matching circuit to determine if more components are necessary in the “pi” network, but cannot be determined before, until we test the board with the antenna on it.

## XV. MOUNTING

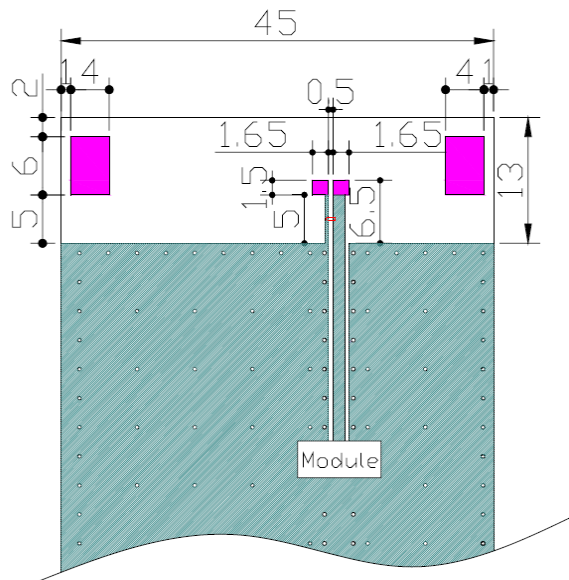

**Figure 7.** Baseline PCB Layout.

The size of the ground plane for the complete evaluation board is 107x45 mm (maximum performance). The size of the entire board including the antenna area free of ground plane is 120x 45 mm. The area occupied by the antenna is 45x13 mm.

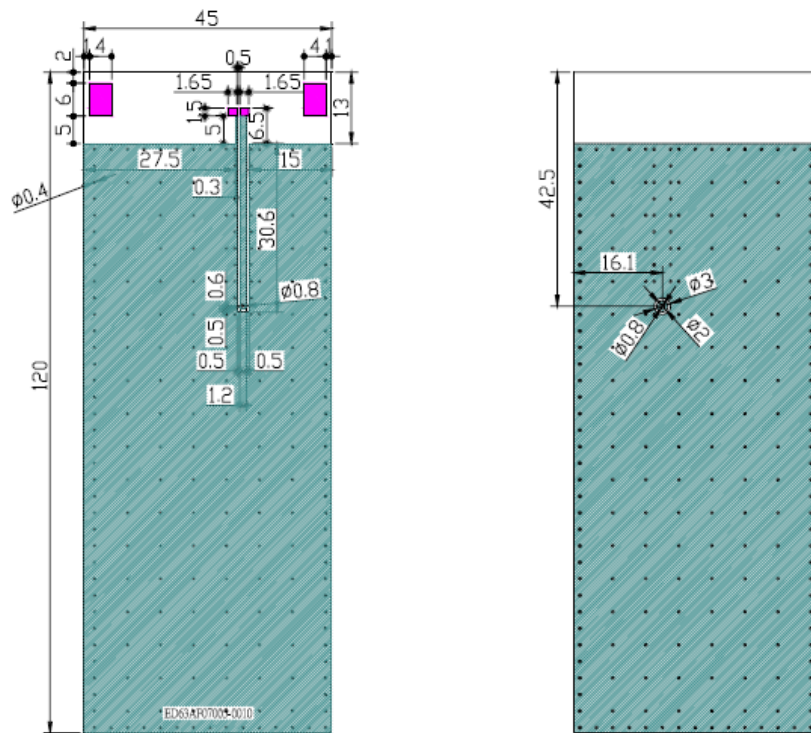
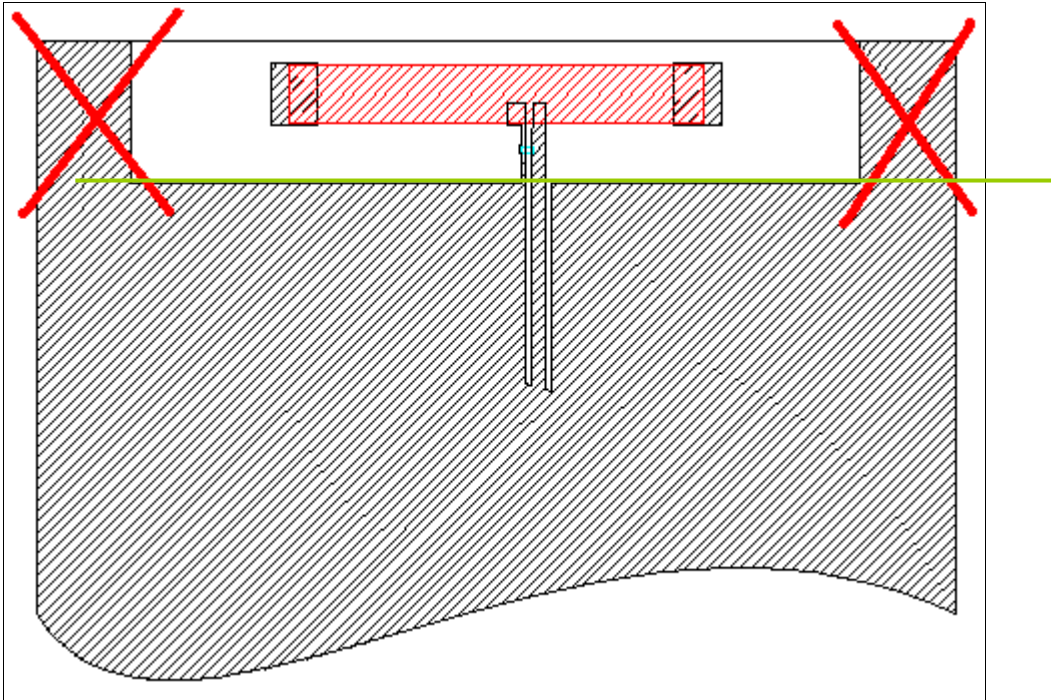

Figure 8. PA.700A EVB Layout.

## XVI. MAJOR NO-NO'S

Under no circumstances must ground plane be placed beside the antenna, nor components, metal screws, or metal structures even if they are not grounded, these metal structures behave like they are grounded. No metal components or ground plane must be placed beyond the edge of the ground plane, above or below the PCB. The edge of the ground plane must be cut in flat shape along that side, as in the green line in the next figure.



**Figure 9.** Solder pad and mask areas.

Do not place metal components, ground plane, daughter boards, LCD or other metal structure near the antenna, on the sides, above, or below on the other side of the board. All these structures must stop at the edge of the ground plane where the green line is drawn in the above figure.

If a thicker component is placed near the end of the ground plane edge, it is at better to have a larger clearance of more than 5 mm, such as an LCD panel, high metal components, etc.

We strictly recommend allocating the antenna in one of the shorter sides for rectangular boards.