



Specification

SPECIFICATION

Model No. : **SGP-13a**

Part No. : **SGP-1575-13-4-A-02**

Specification No : **SP03AB15752-0030**

Product Name : **GPS SMT Patch Antenna**

Features : 13*13*4mm
1575MHz Centre Frequency

RoHS ✓



REVISION STATUS

Version	Date	Page	Revision Description	Prepared	Approved
01	17 th July 2008	All	New release	TW Product Centre	Ronan Quinlan



1.0 Introduction

This miniaturized ceramic GPS patch antenna is based on smart **XtremeGain™** technology. It is mounted via SMT process and has been selected as optimal solution for the 35*35mm ground plane.

2.0 Key Antenna Performance Indicators

Original Patch Specification tested on 35mm ground plane

No	Parameter	Specification
1	Range of Receiving Frequency	1575MHz +/- 1.023MHz
2	Center Frequency**	1575MHz ± 3MHz when tested on a 35m ² Ground Plane
3	Bandwidth	6 MHz min with Return Loss $\leq -10\text{dB}$
4	VSWR	1.5 max
5	Gain at Zenith	-1.0 dBi typically
6	Impedance	50 Ω
7	Axial Ratio (at Zenith)	4.0 dB max
8	Polarization	Right Hand Circular Polarization
9	Frequency Temperature Coefficient	0 ± 20 ppm/ °C max @ -40°C to +105°C
10	Operating Temperature	-40°C to +105°C

****Changes in user groundplane and environment will offset centre frequency**



Specification

3.0 Mechanical Specifications

3.1 Dimensions and Drawing

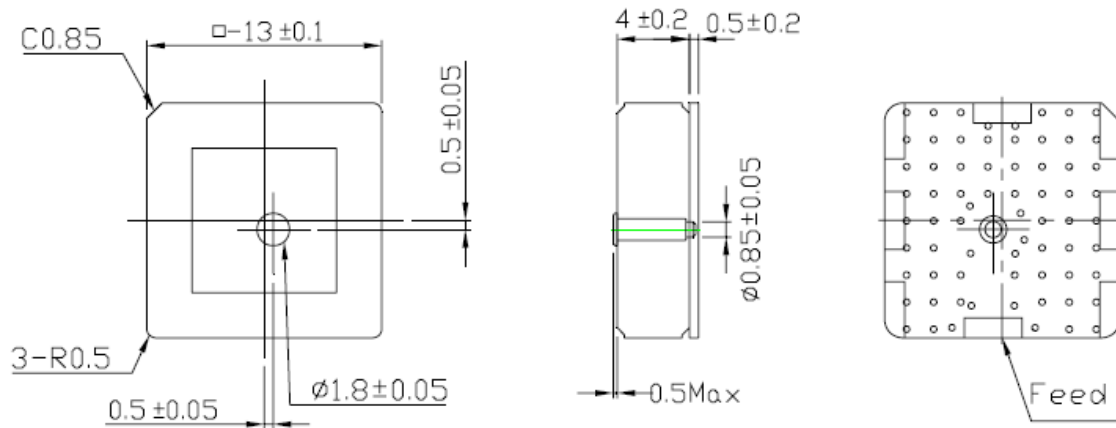

3.2 Antenna Foot Print

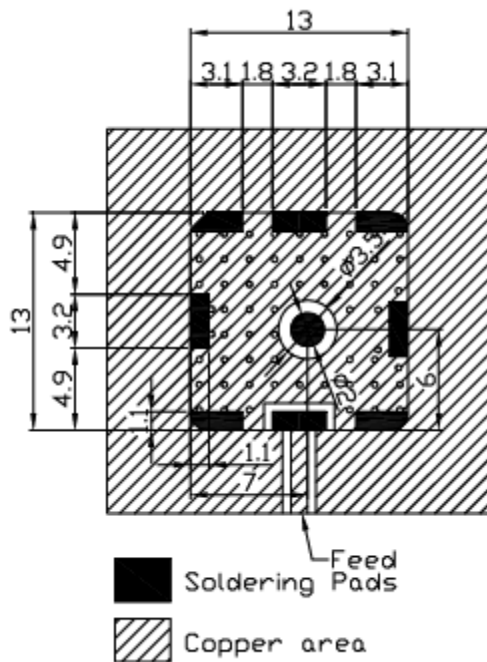



Specification

3.3 Test Jig and Dimension

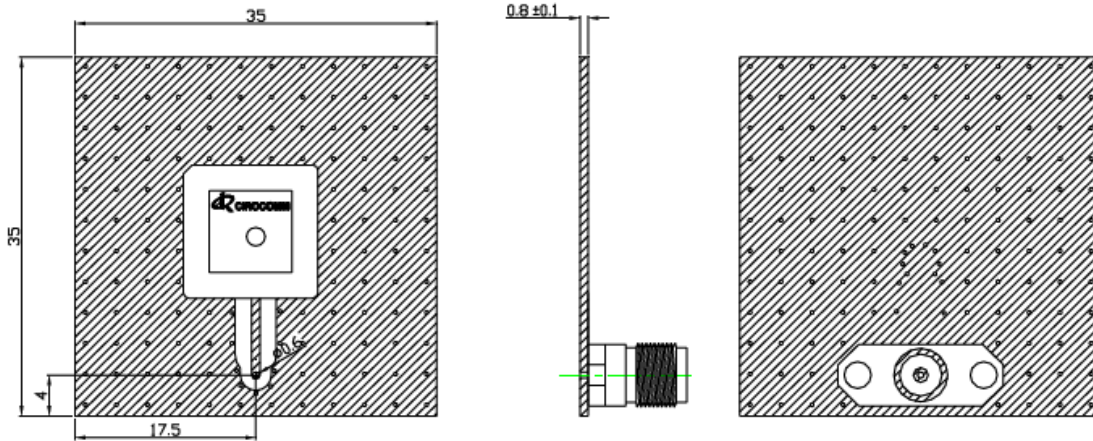

3.4 Test Fixture set up and measurements

Test Fixture

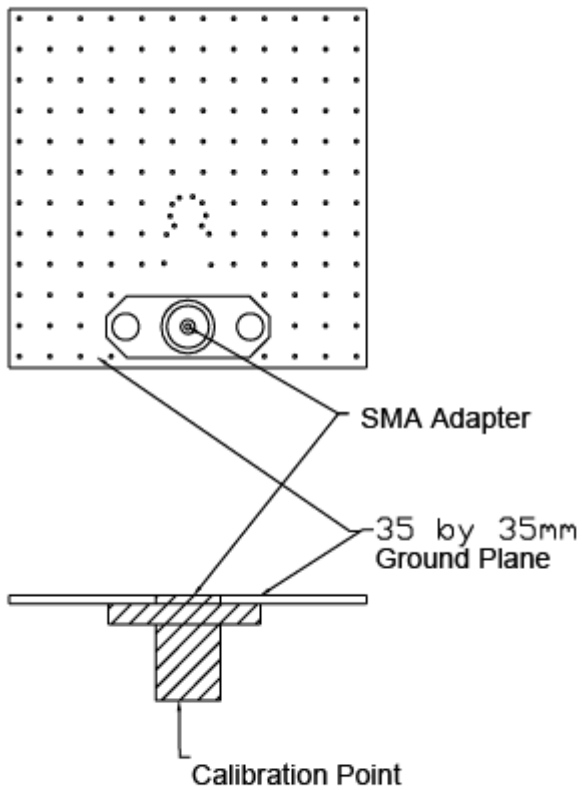

Antenna Setup & Measurements

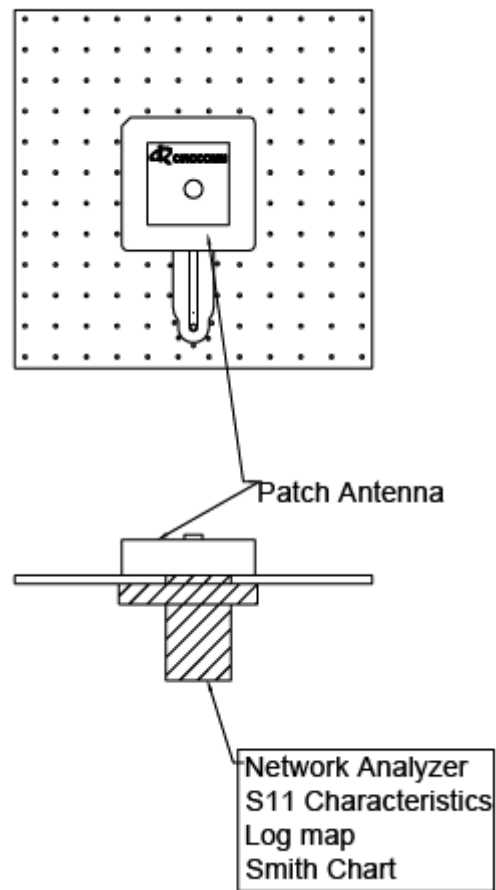



3.5 Delivery Mode

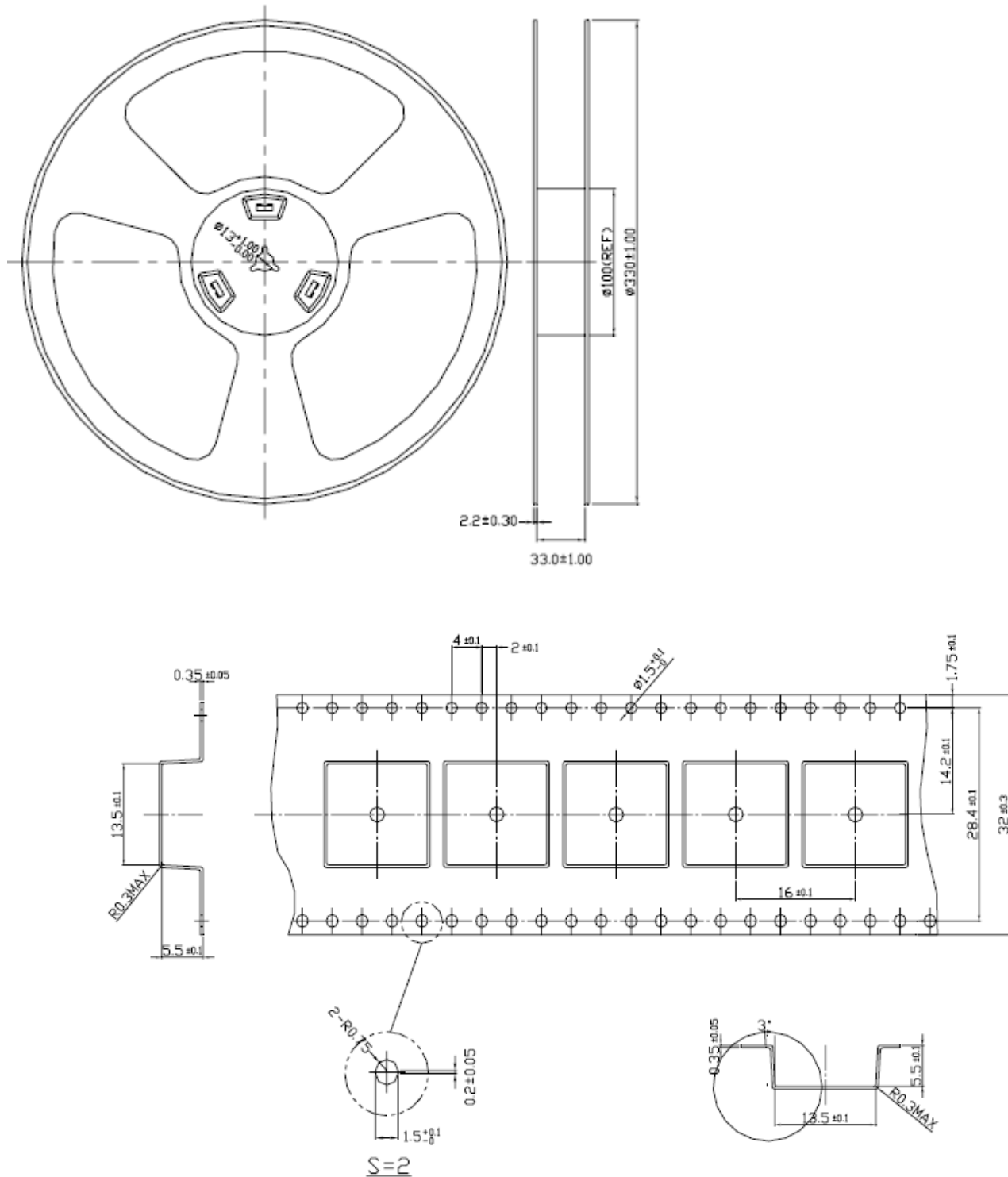



4.0 Electrical Specifications

4.1 Smith Chart

