

SPECIFICATION

- Part No. : **TI.18.3113**
- Product Name : 3dBi 868MHz ISM Band Dipole Terminal
Antenna, SMA(M) Hinge
- Feature : High efficiency dipole terminal antenna
ROHS compliant



I. Introduction

TI.18 is high performance 868MHz ISM band dipole omni-directional antenna. The SMA connector is for general purpose used and the hinged design enables the antenna to be positioned at its most suitable angle.

For a lot of antenna applications, such as Wi-Fi Hotspot or cellular Pico-cell, the antenna of the operator's device and the antenna of the user's remote device are not on the same horizontal level. So rather than having the usual dipole antenna with dumbbell shape radiation pattern in the E-plane cross-section, we have designed this antenna with butterfly shape radiation pattern. This way, the best radiation direction of TI.19 will be more pointed to the remote user.

II. Specification

ELECTRICAL	
Frequency	868 ~ 870MHz
Peak Gain (bend)	3.2dBi
Peak Gain (straight)	3.2dBi
Average Gain (bend)	-0.3dBi
Average Gain (straight)	-0.3dBi
Efficiency (bend)	92%
Efficiency (straight)	93%
Impedance	50Ω
VSWR	< 1.9 : 1
Polarization	Linear
Radiation Pattern	Omni
Input Power	10 W
MECHANICAL	
Antenna Length	375 ± 5 mm
Antenna Diameter	12.5 ± 0.5 mm
Casing	TPU
Connector	SMA Male
ENVIRONMENTAL	
Temperature Range	-40°C to 85°C
Humidity	Non-condensing 65°C 95% RH

III. Antenna S11 Properties

Return Loss

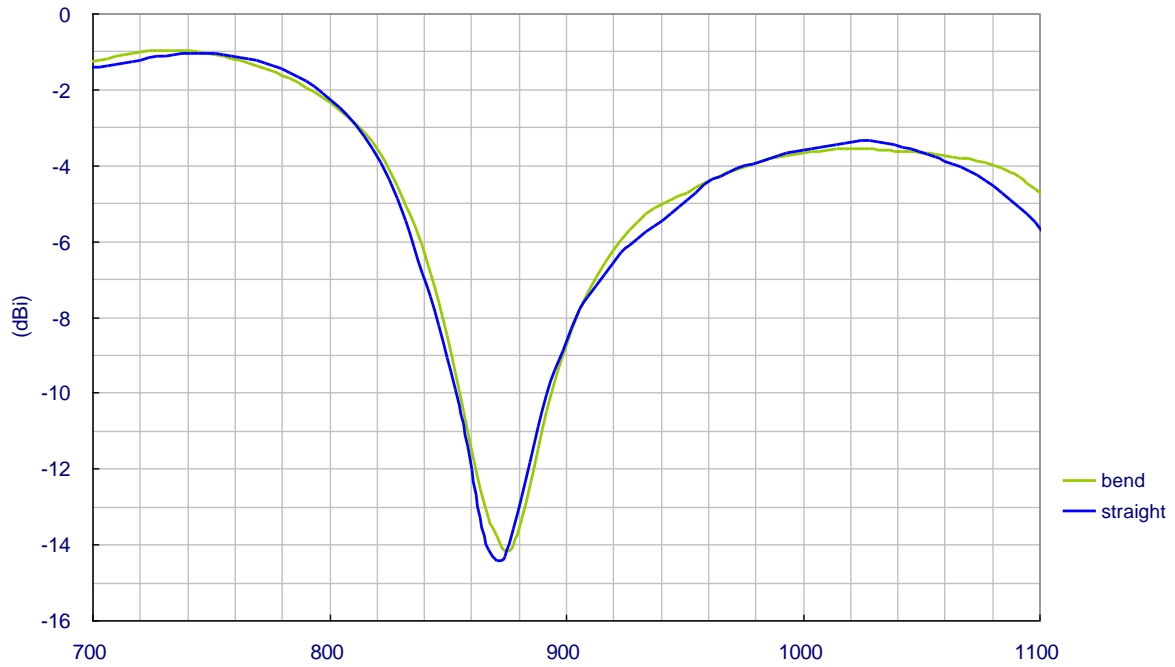

VSWR

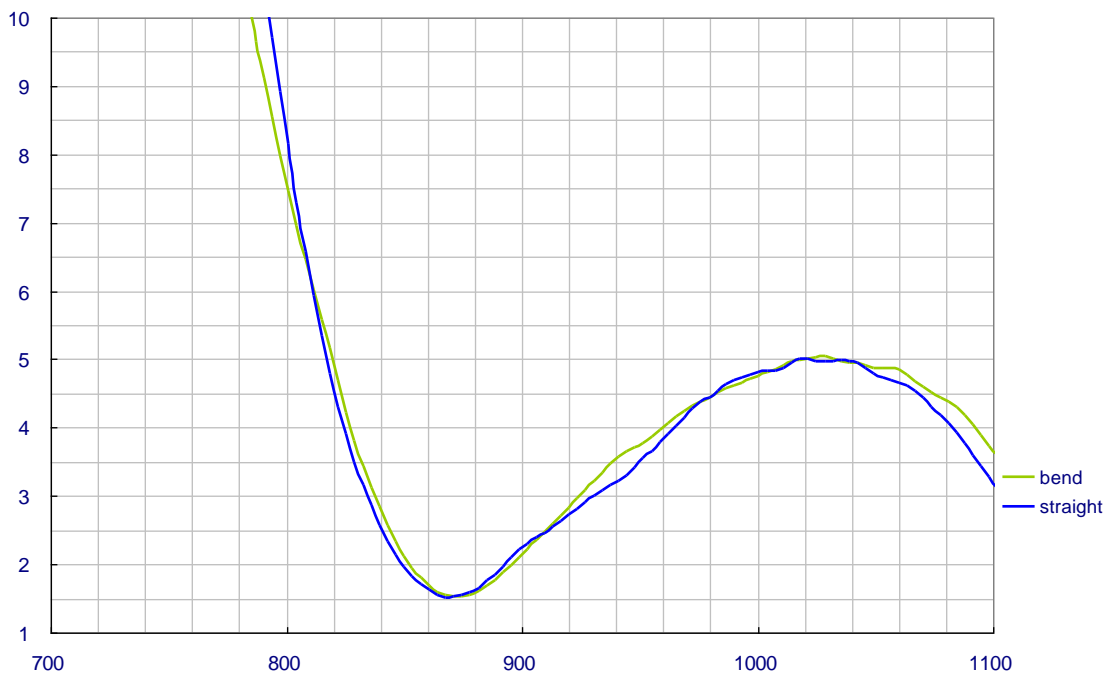

IV. Antenna Free Space Radiation Properties

IV.1. 3D Radiation Efficiency

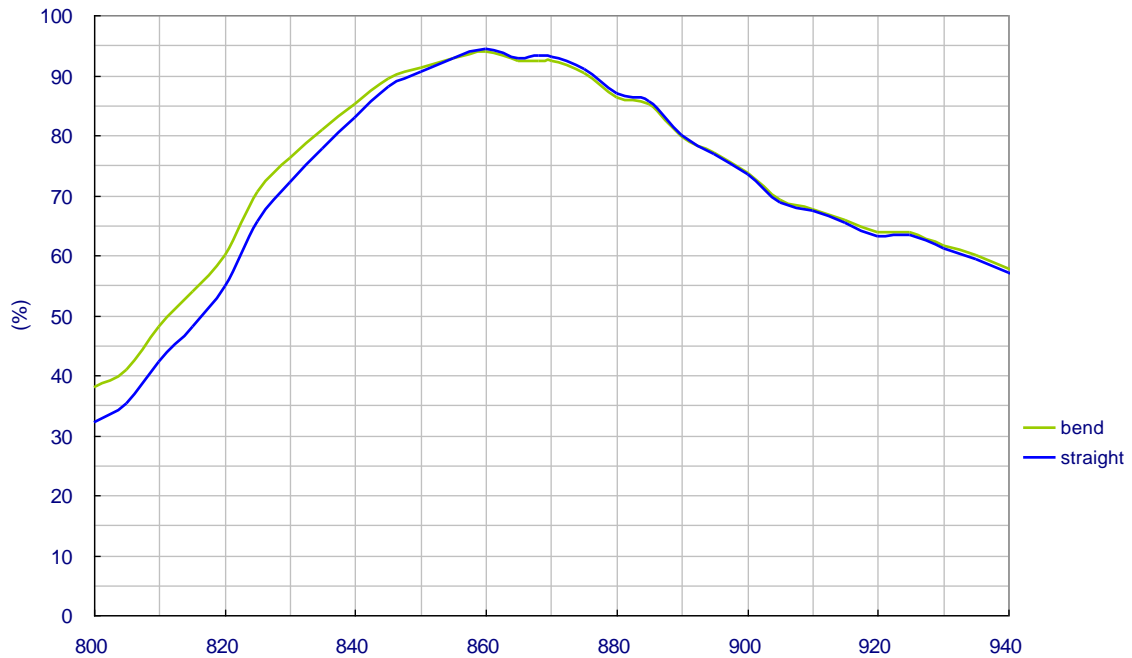

IV.2. Peak Gain

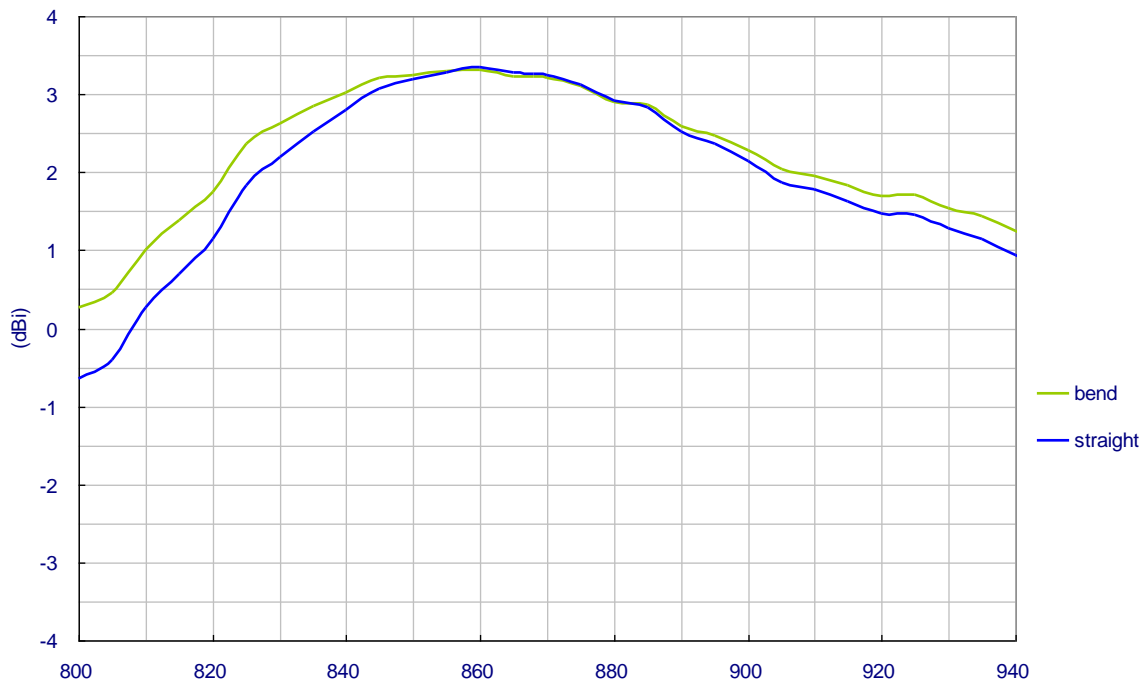

IV.3. Average Gain

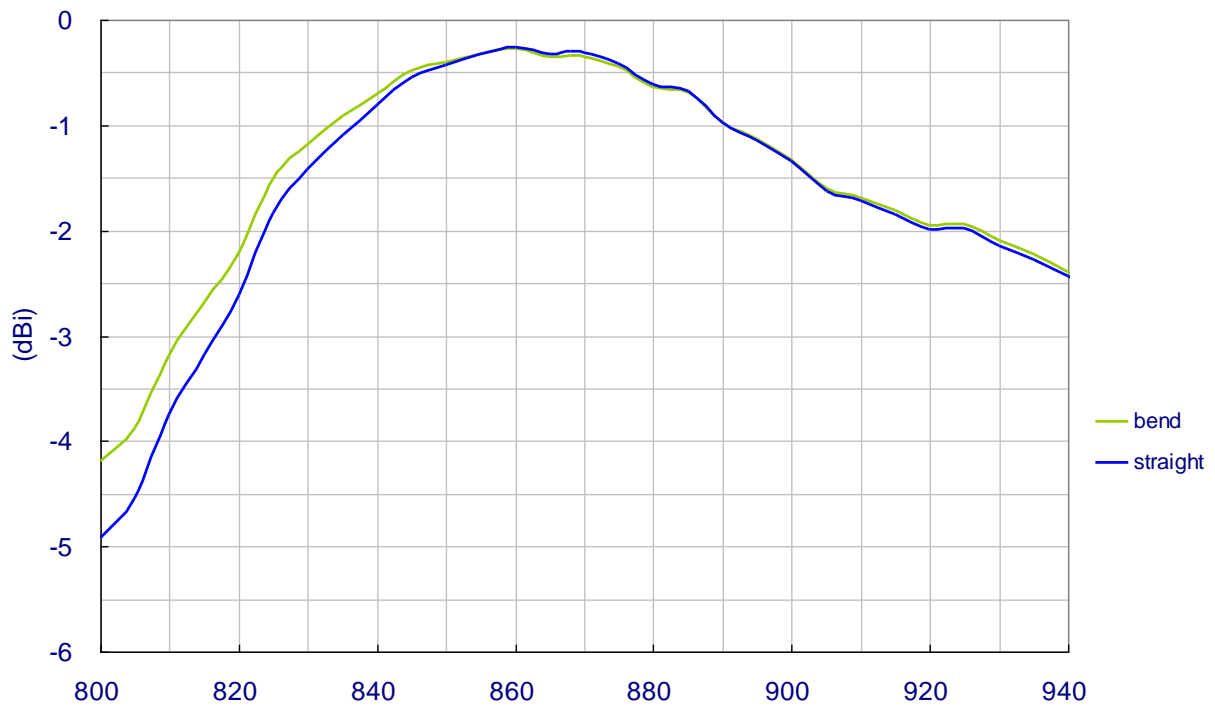

IV.4. Radiation Pattern of 90 Degree Bend Position

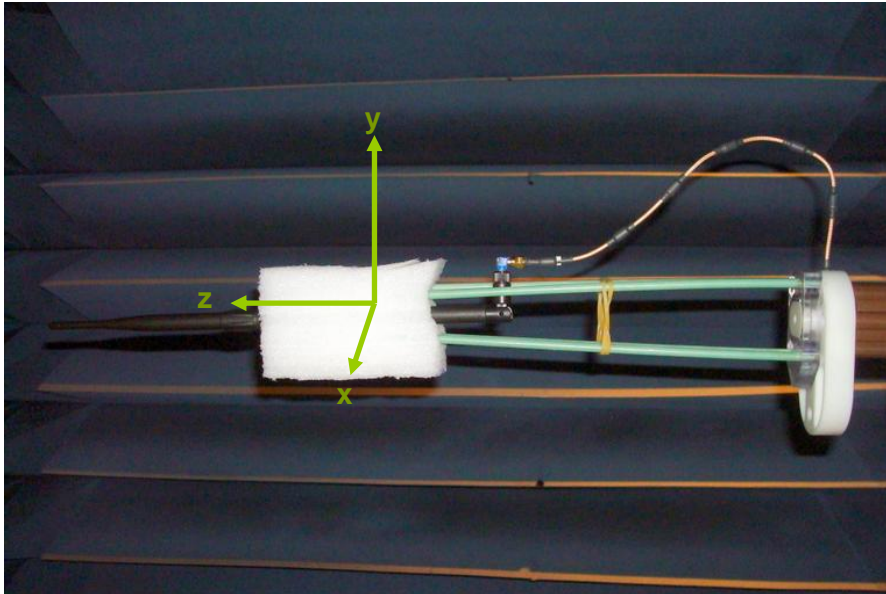

3D Radiation Pattern

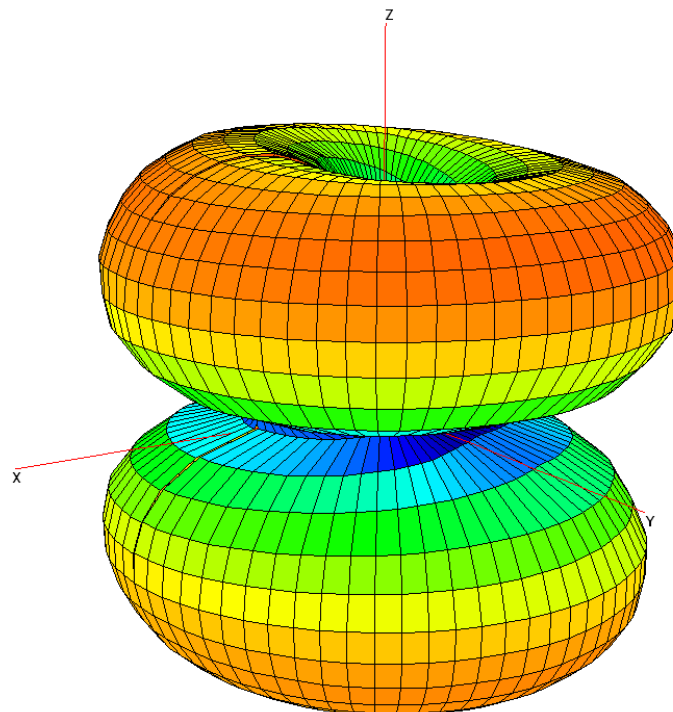

X-Z Plane Radiation

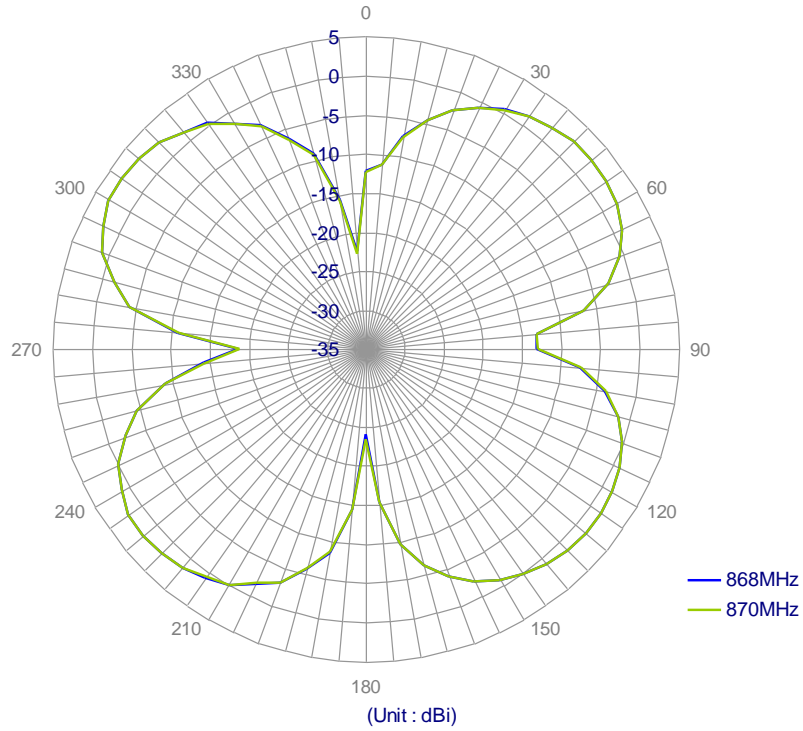

X-Y Plane Radiation

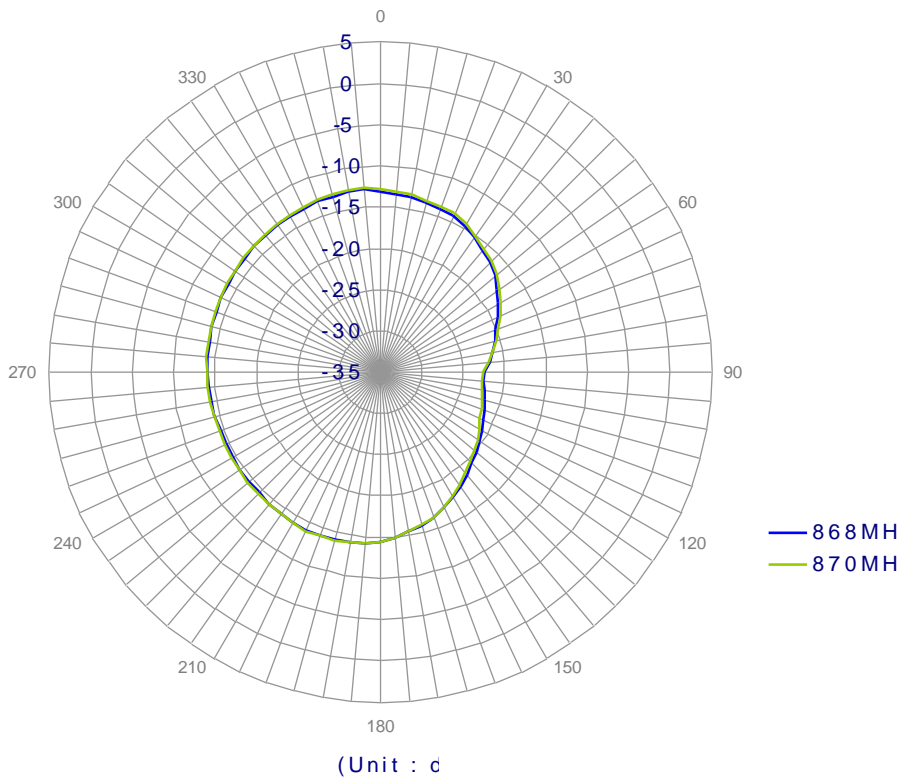

Radiation at 45 Degree from XY Plane

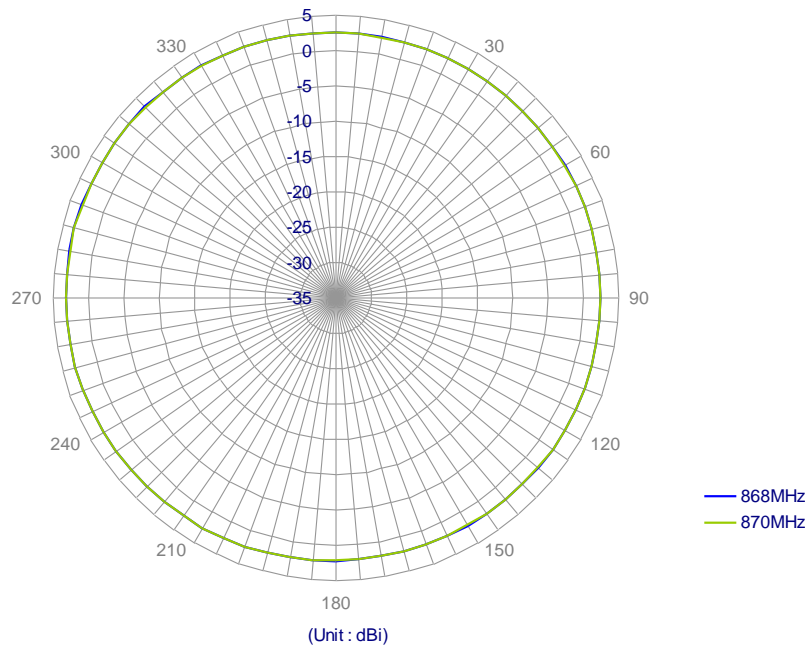

IV.5. Radiation Pattern of 180 Degree Straight Position

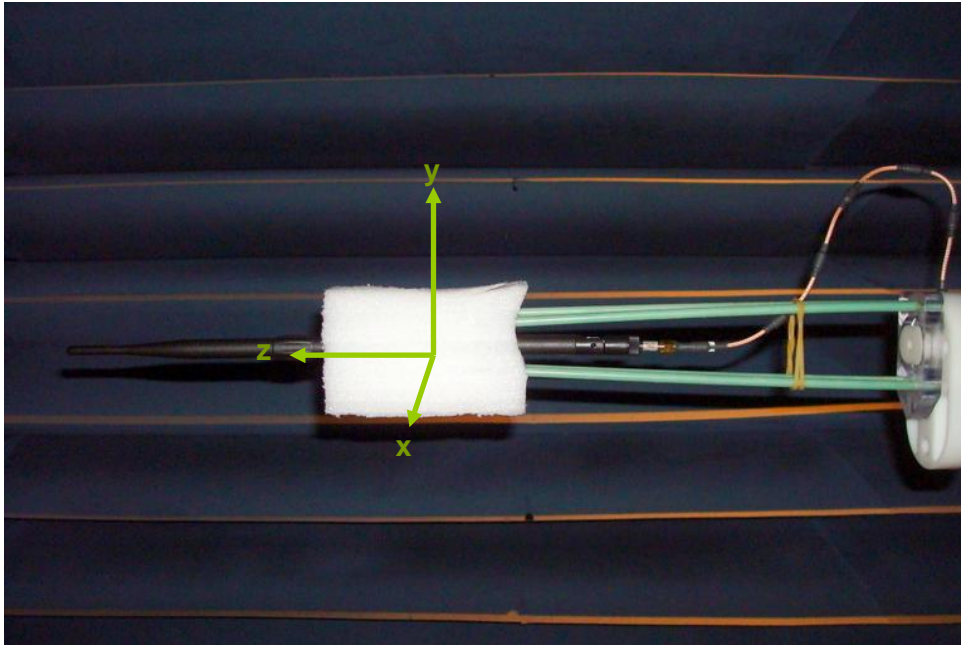

3D Radiation Pattern

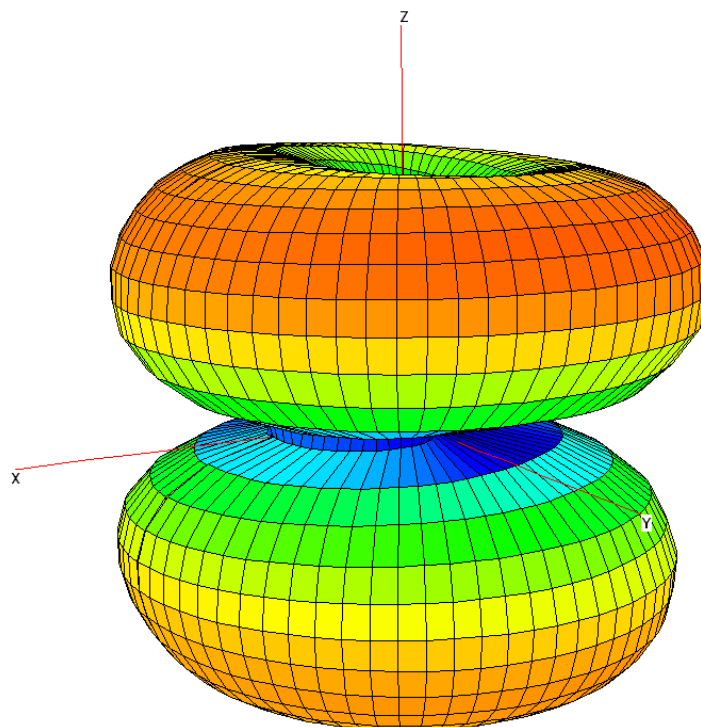

X-Z Plane Radiation

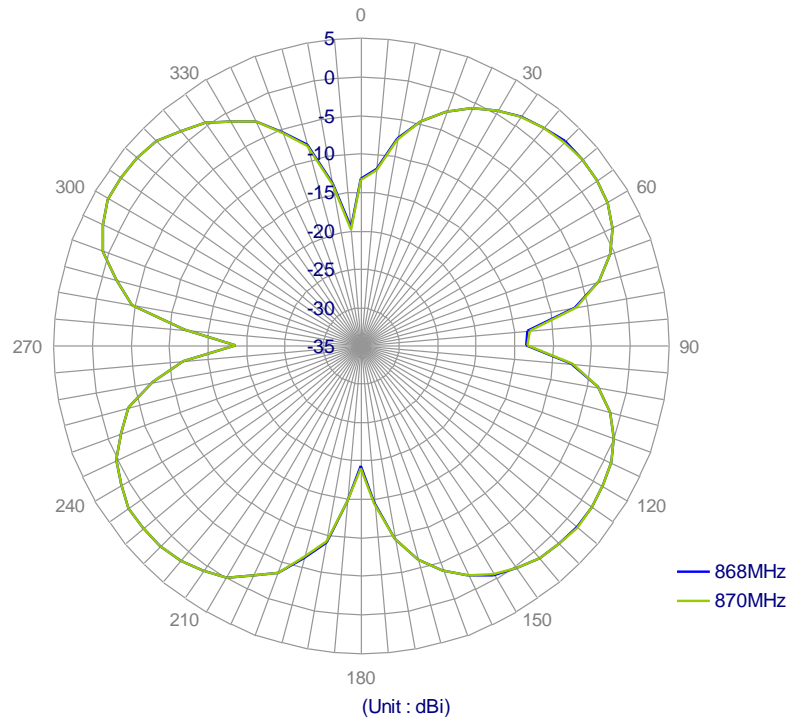

X-Y Plane Radiation

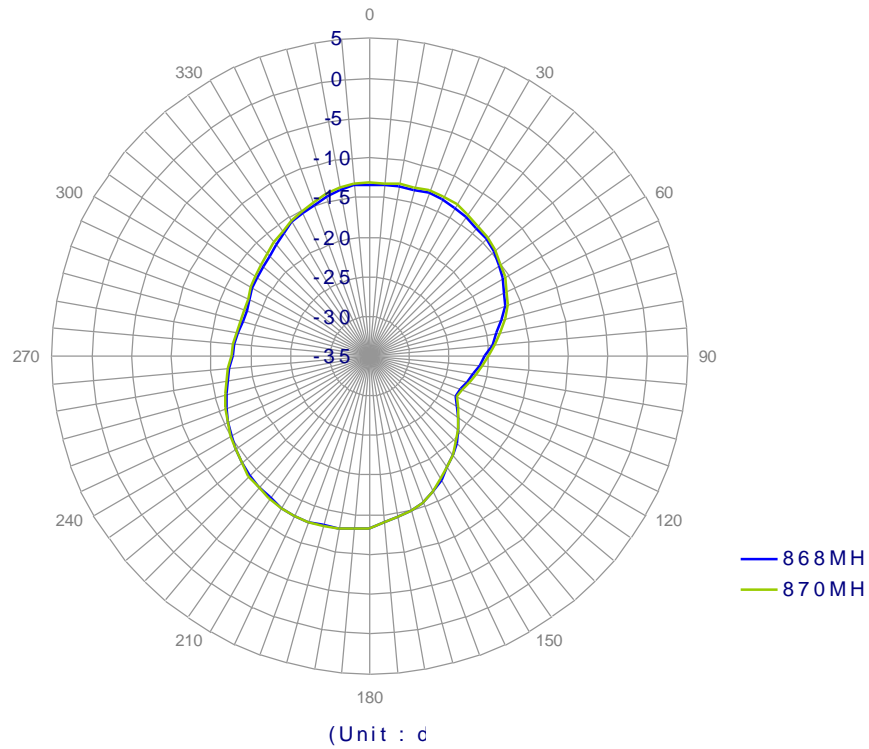

Radiation at 45 Degree from XY Plane

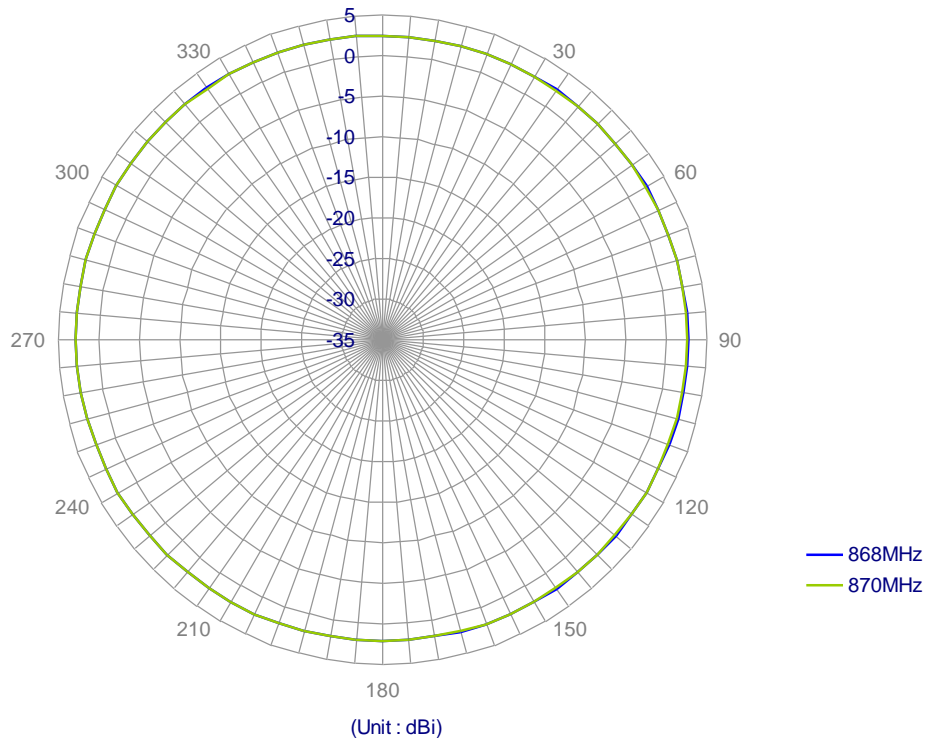

V. Ground Plane Effect

Three ground setups are used to see the affect of positioning TI.18 close to ground -

1. Small Ground (15 x 9cm) – common size of CPE devices. TI.18 is mounted at the longer edge for testing.
2. Big Ground Edge (45 x 30cm) – simulate the effect of mounting antenna on a base station device. TI.18 is mounted at the centre of the longer edge.
3. Big Ground Centre (45 x 30cm) – simulate the effect of mounting antenna in a centre of a big ground plane, such as vehicle top.

V.1. S11 Retune Loss

Bend

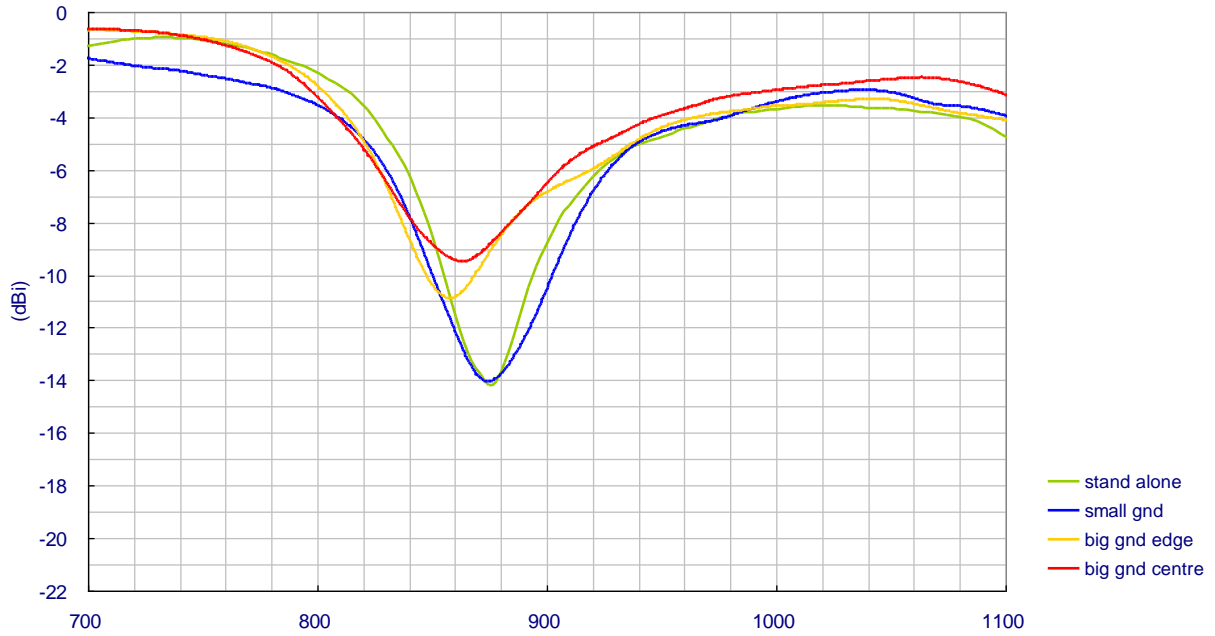

Straight

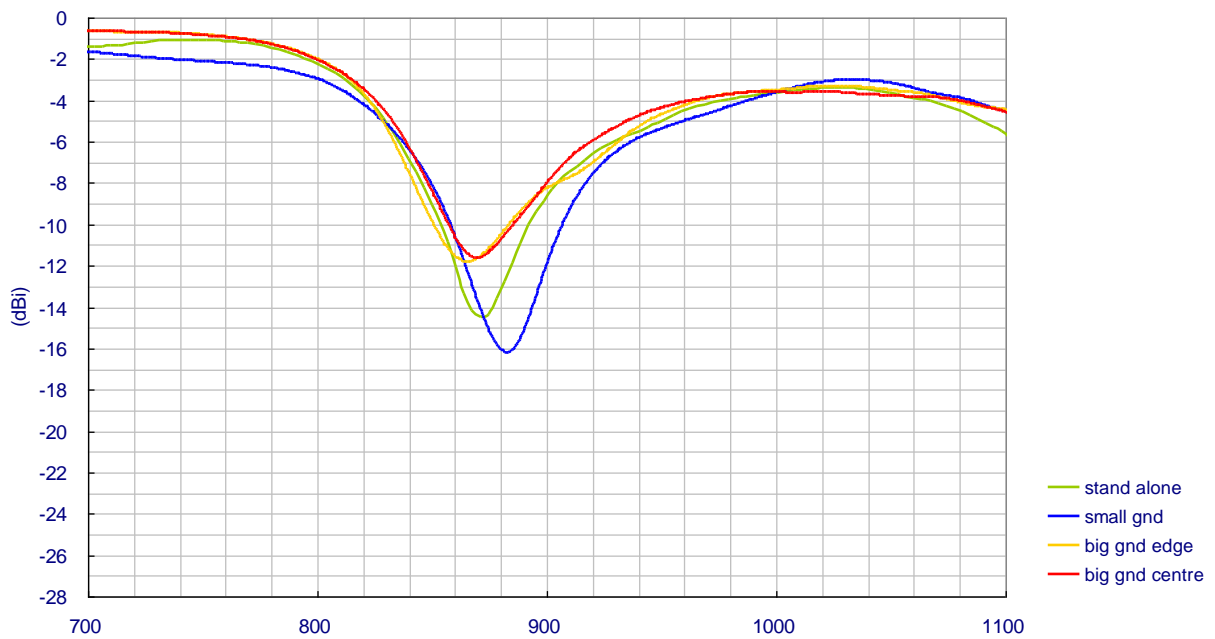

V.2. VSWR

Bend

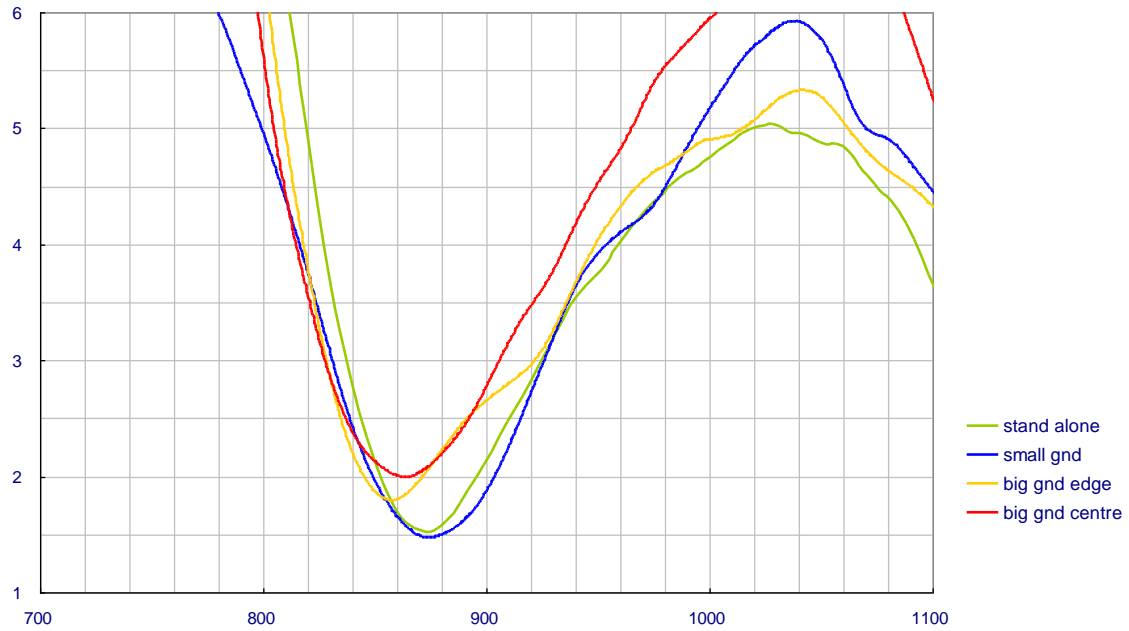

Straight

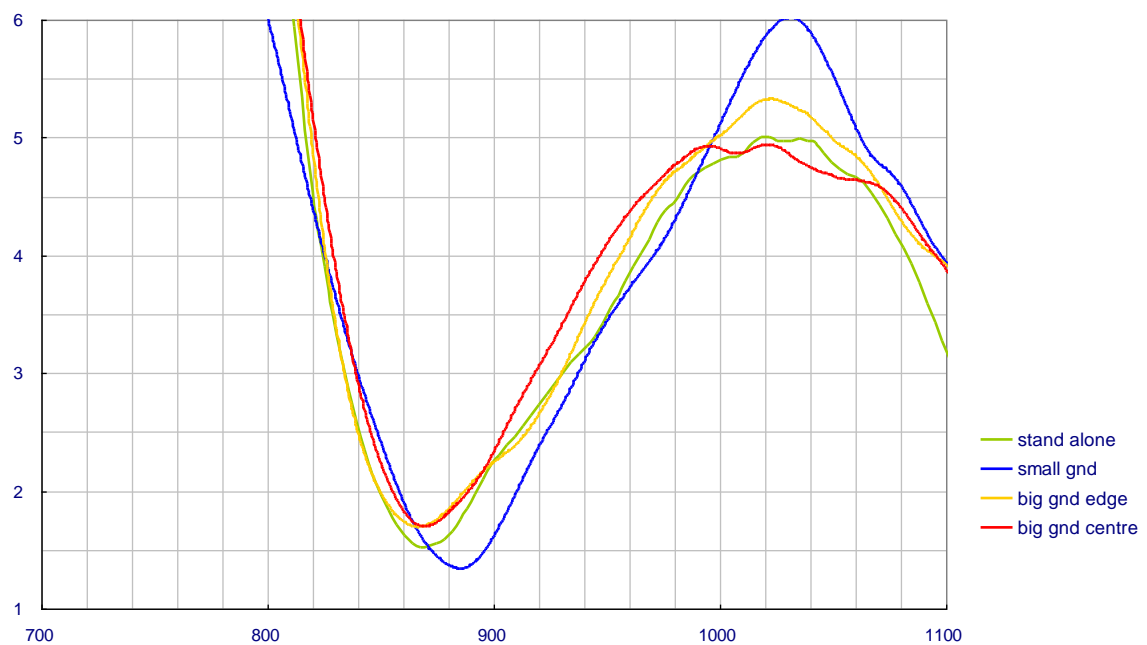

V.3. Radiation Efficiency

Bend

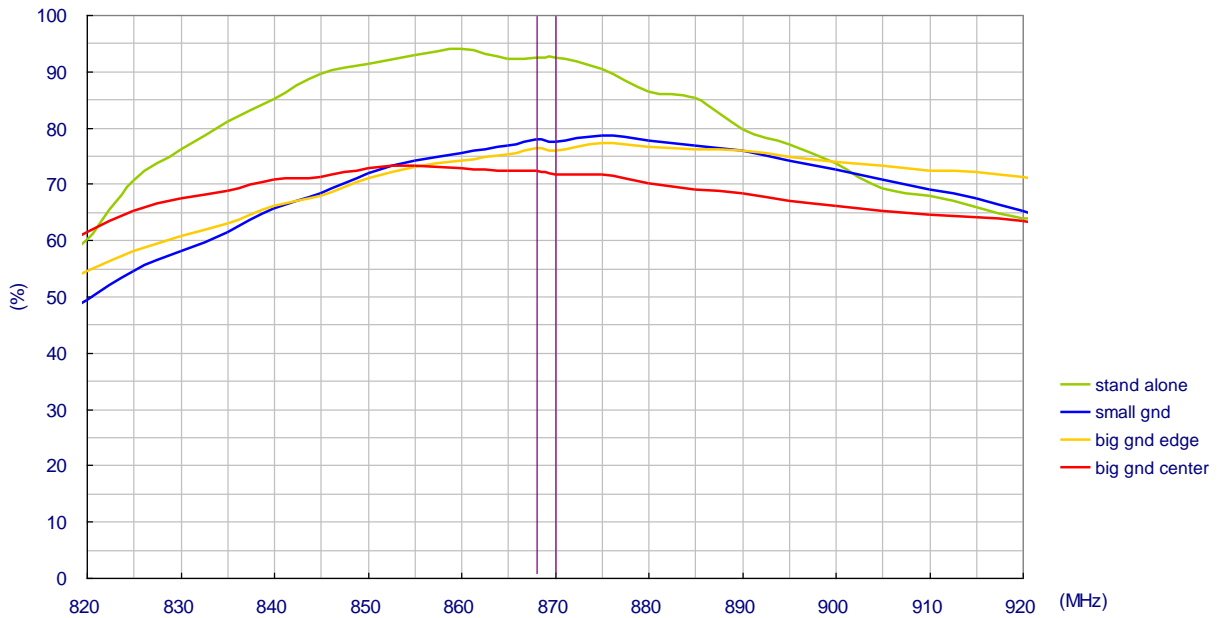

Straight

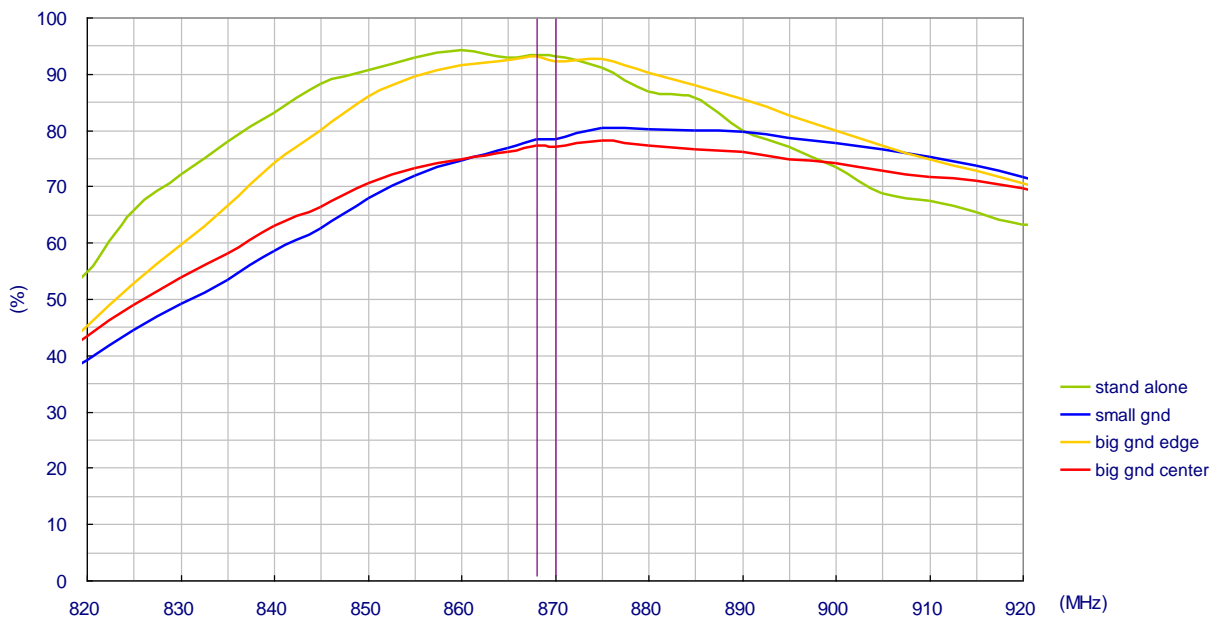

V.4. Average Gain

Bend

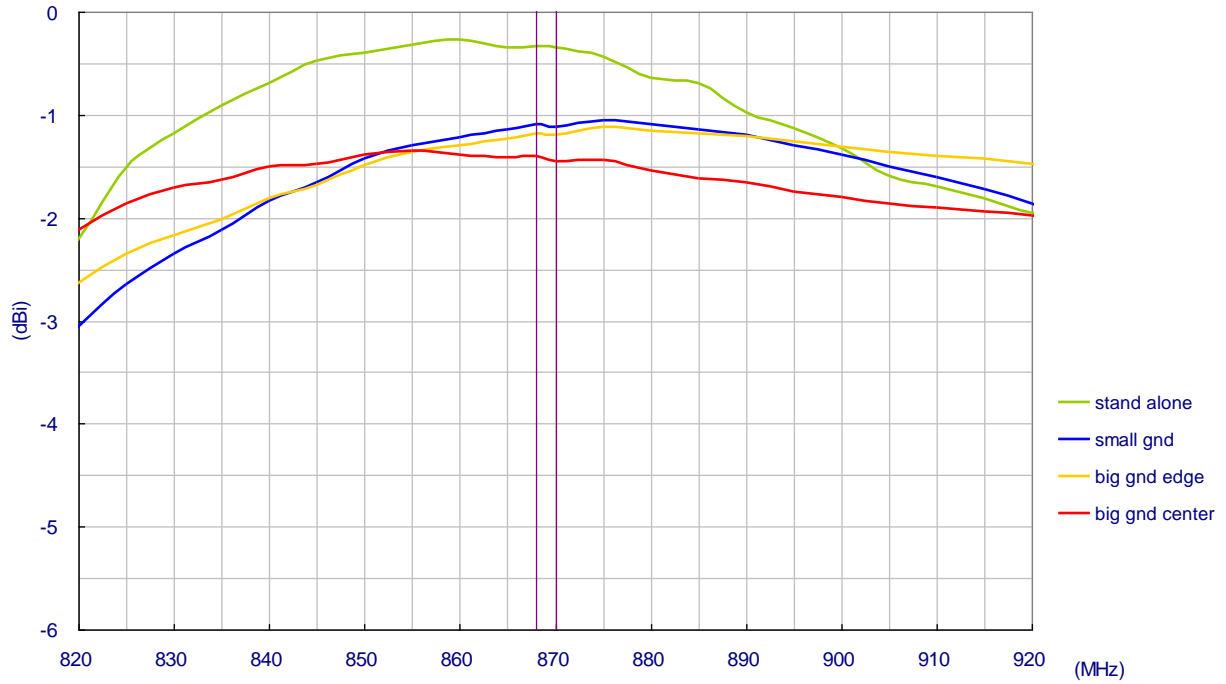

Straight

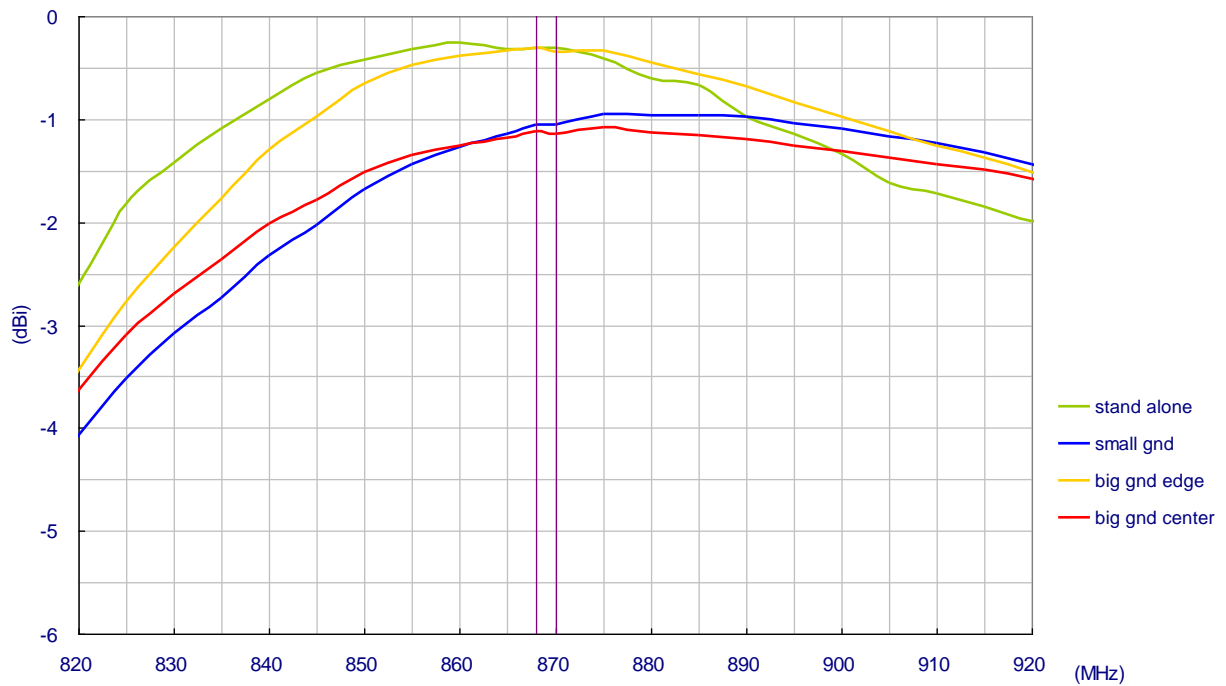

V.5. Peak Gain

Bend

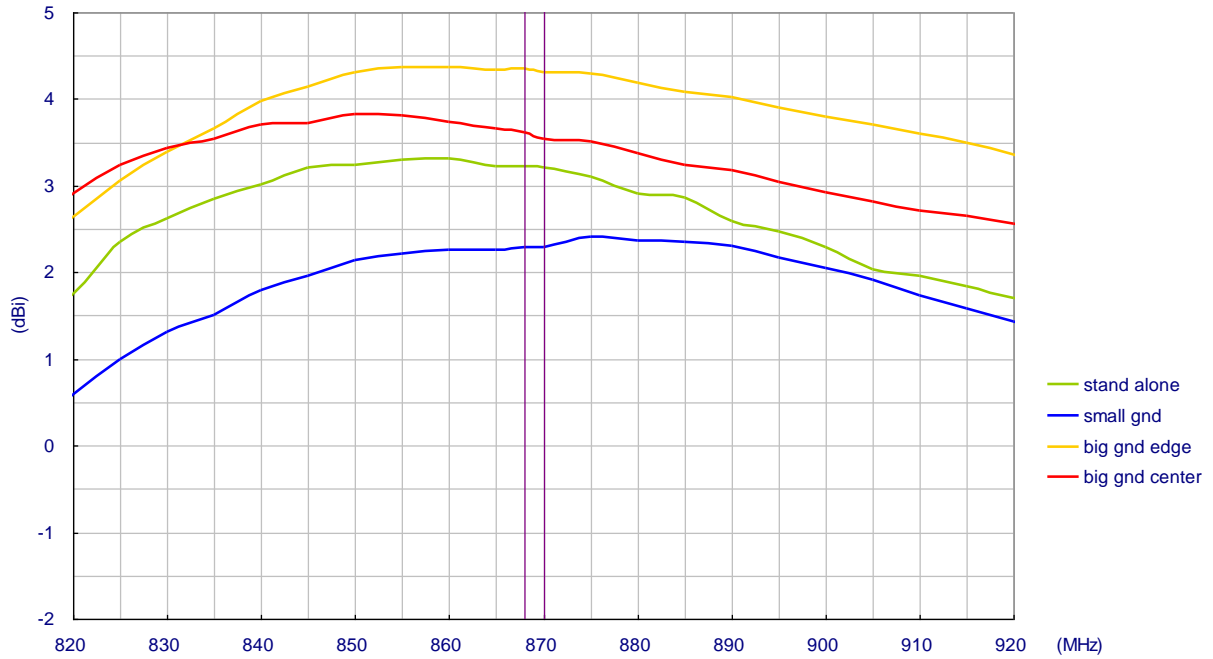

Straight

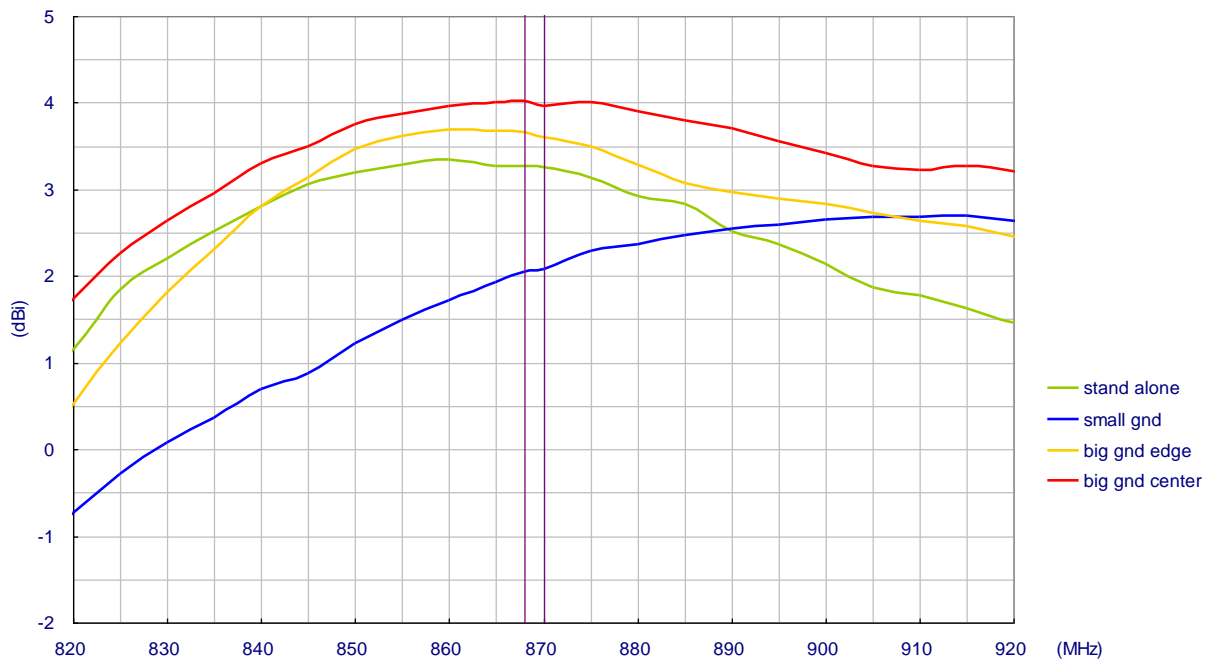

V.6. Radiation Pattern of 90 Degree Bend Position

X-Z Plane Radiation

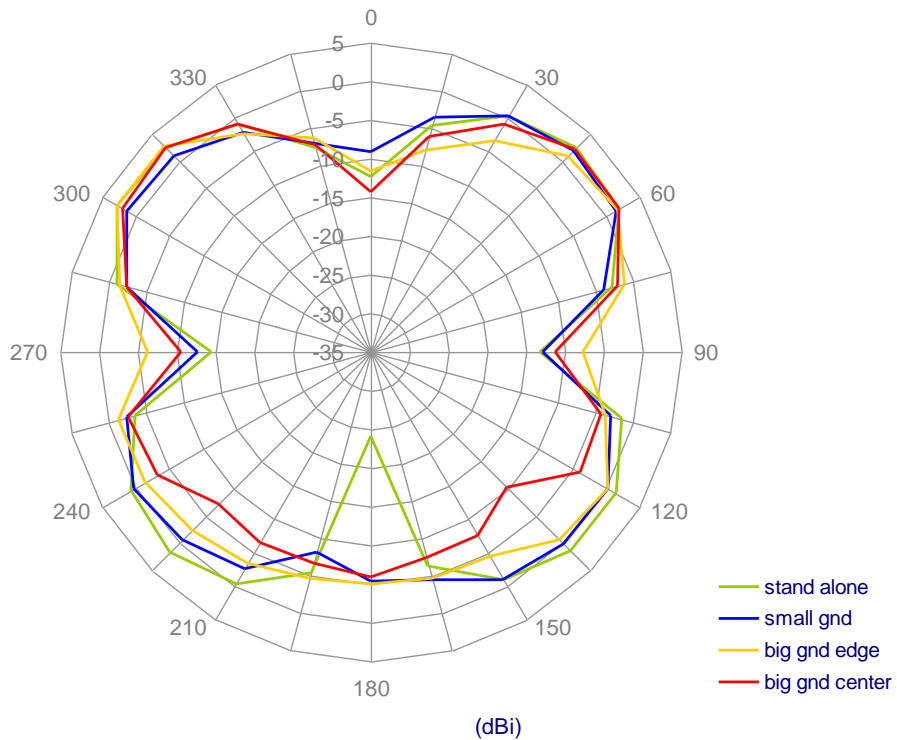

X-Y Plane Radiation

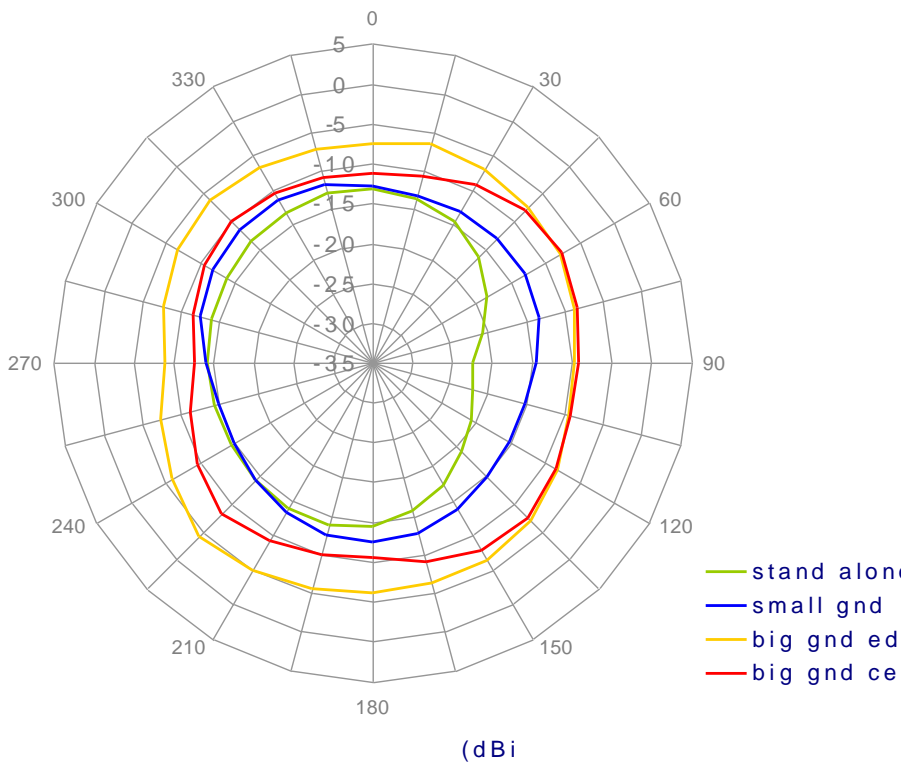

Radiation at 45 Degree from XY Plane

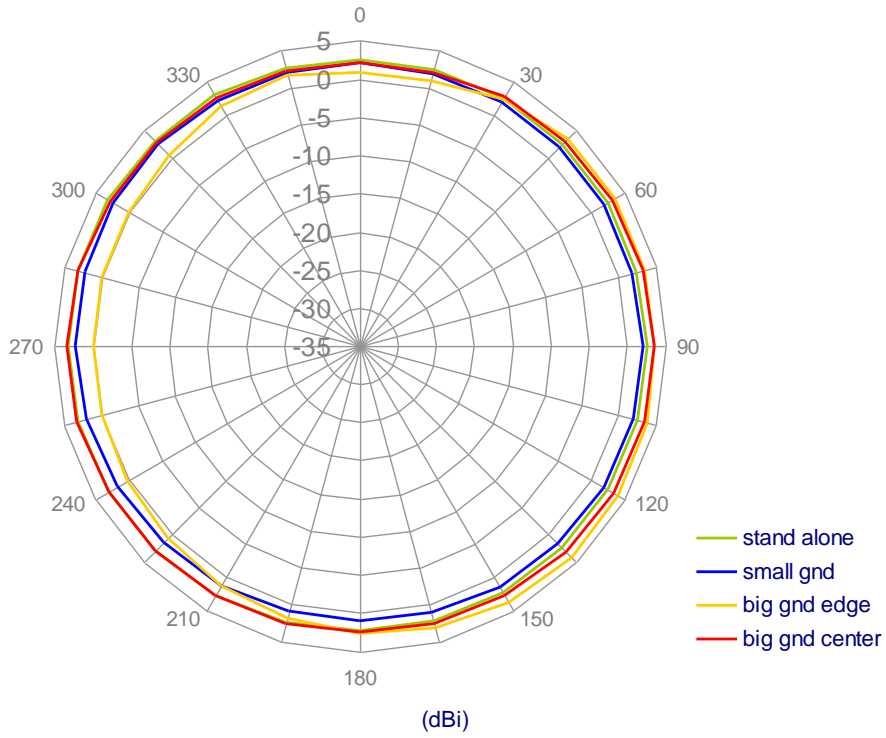

V.7. Radiation Pattern of 180 Degree Straight Position

X-Z Plane Radiation

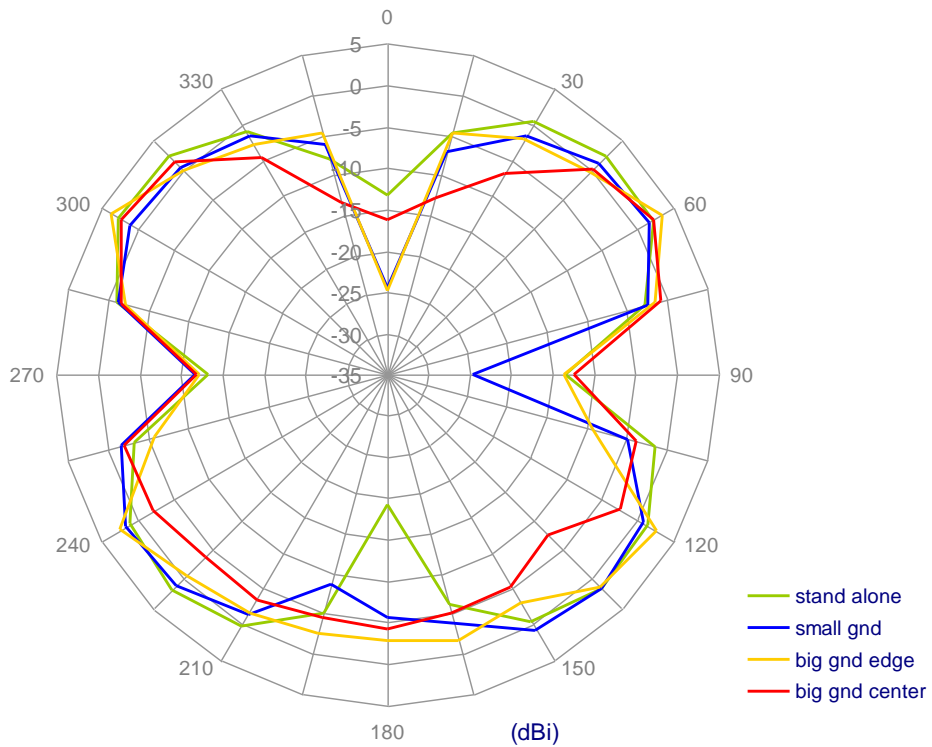

X-Y Plane Radiation

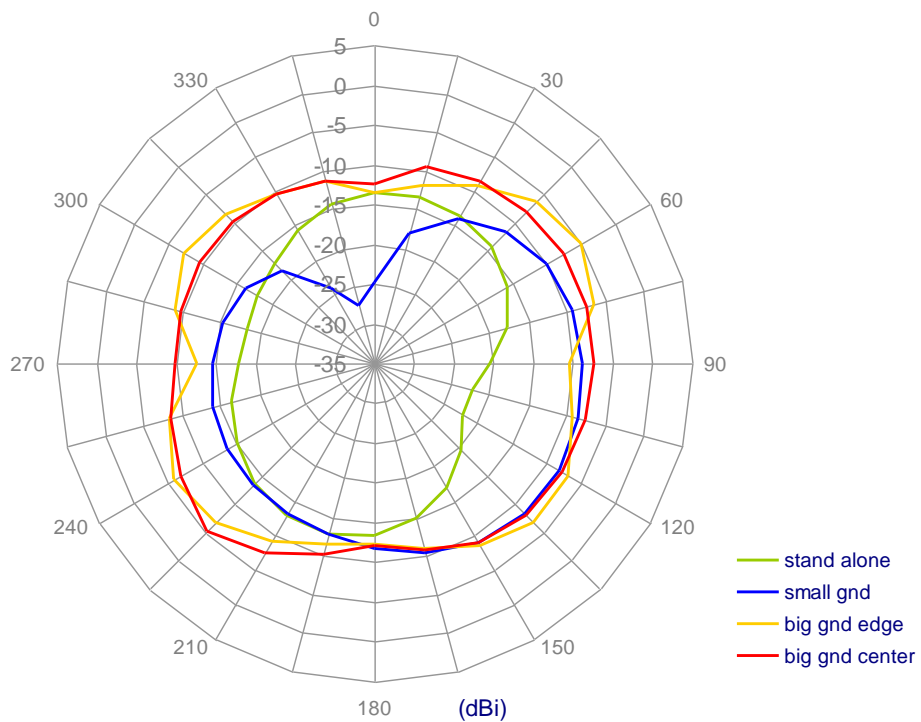

Radiation at 45 Degree from XY Plane

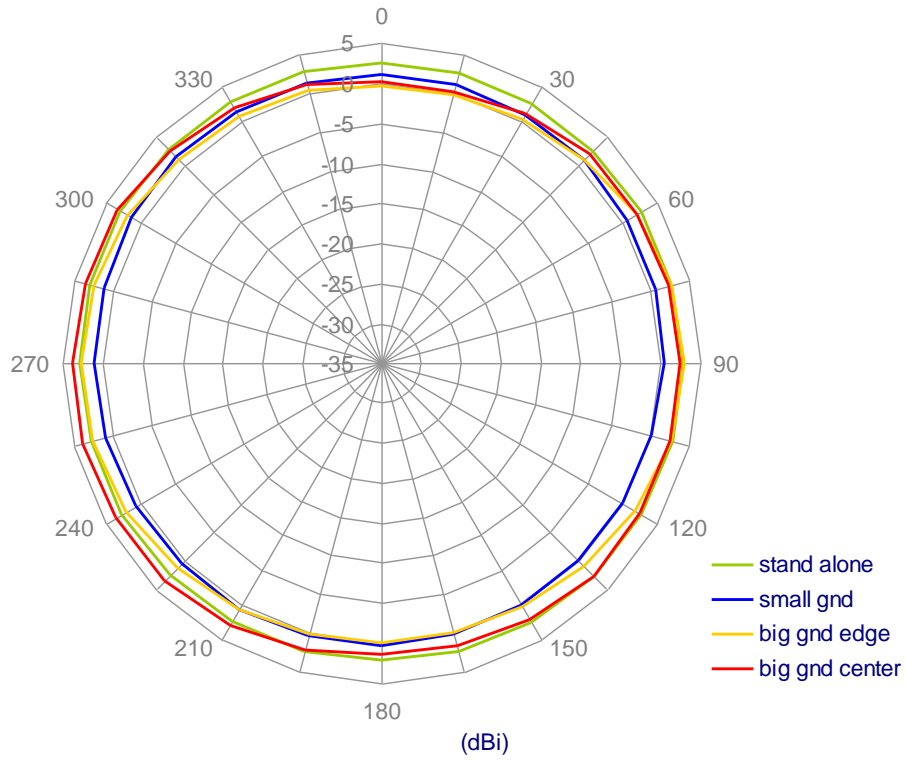

VI. Mechanical Drawing

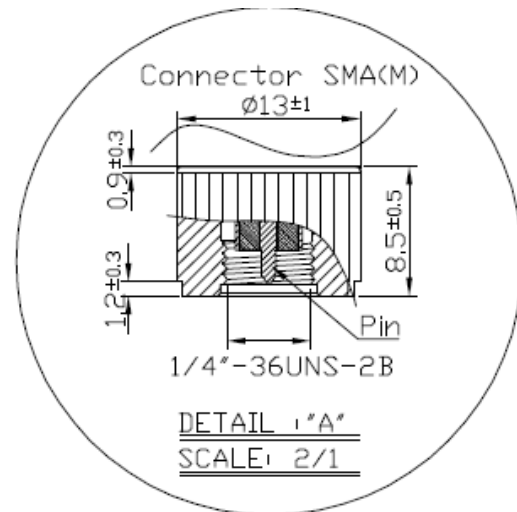
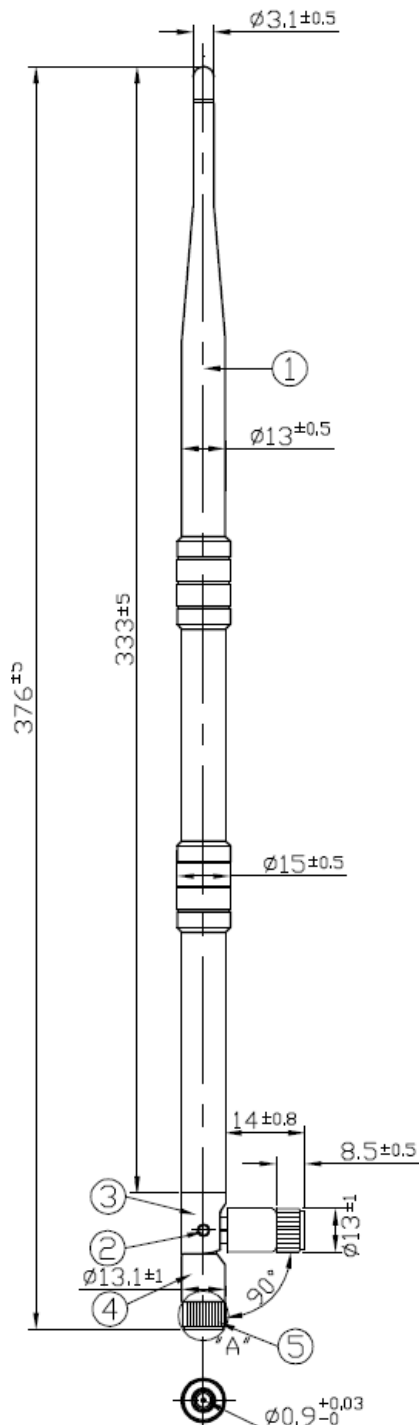

	Name	Material	Finish	QTY
①	Antenna Housing	TPU	Black	1
②	Rotary Shaft	Brass	Black	1
③	Upper Base	ABS+PC	Black	1
④	Bottom Base	ABS+PC	Black	1
⑤	SMA(M)	Brass	Black	1

Unit : mm