

PCN – Process Change Notification

Change:	CAB.954_Cable & Connector Tolerances
Date:	2016/05/25
Author	Haley Tsai

Affected Products

Model#	Part Number	Changes
CAB.954_ N Type Jack with O-Ring to 300mm(11.8") 1.37mm IPEX MHFI	CAB.954	Tolerance Change.

Type of Change

- Hardware Modification
 Production Process Advance
 Others – Tolerance Changing
-

Description of Change

We have improved the cable/connector joint reliability for thinner cables by adding a protective extra metal tube crimped over the cable to protect the solder joint, also updated connector and cable length tolerance.

Schedule

2016, January, Taoglas will change new tolerance into production drawing.

Forecast Estimated Transition Date

Jan/2016

Illustration of Change

Old drawing tolerance

EDW

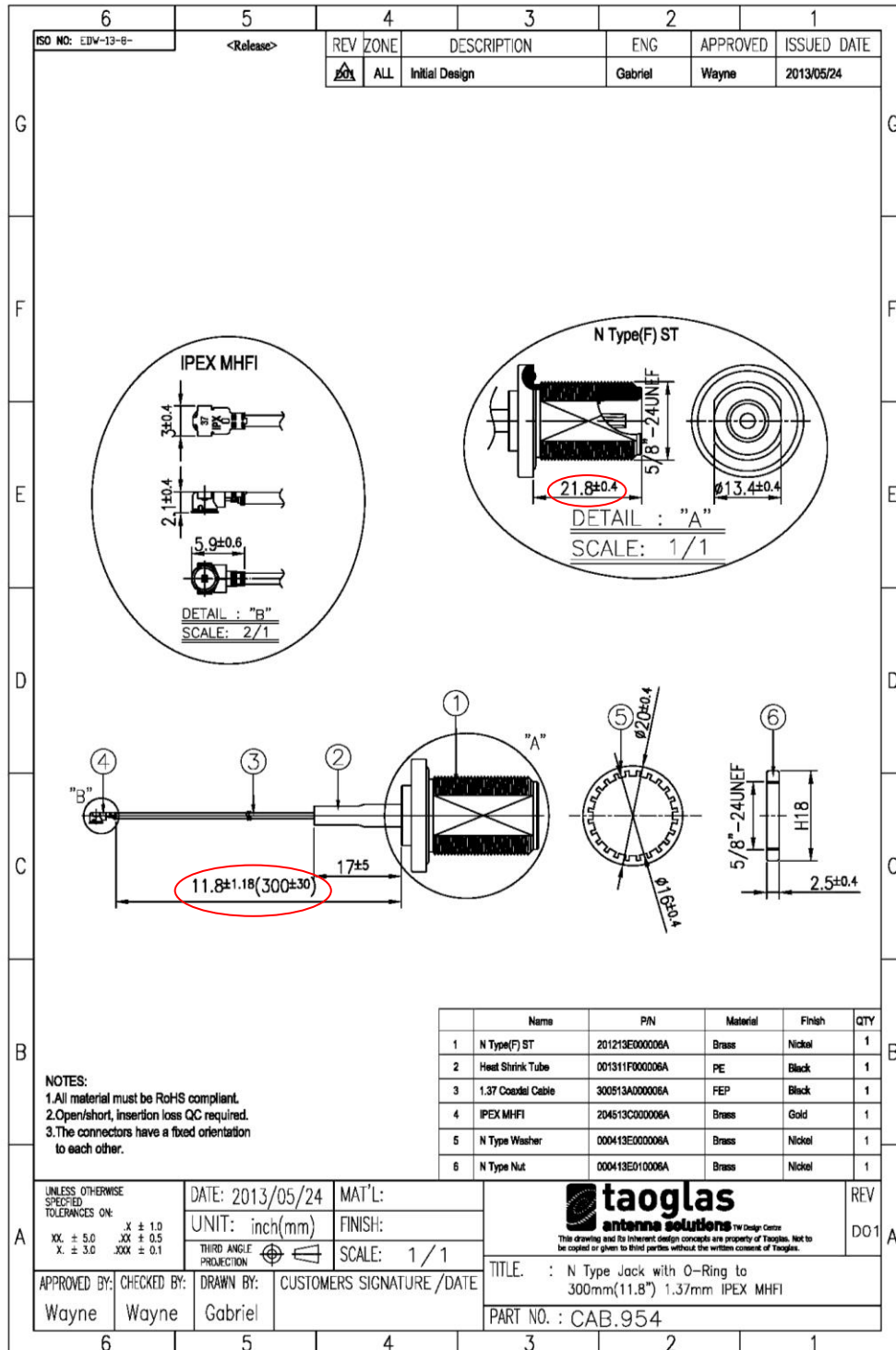

New drawing tolerance

EDW

