

PCN – Process Change Notification

Change:	FW.90.SMA.M
Date:	2017/08/04
Author	Haley Tsai

Affected Products

Model#	Part Number	Changes
FW.90 Penta-band Cellular Flexible Whip Antenna SMA(M) Straight	FW.90.SMA.M	<ol style="list-style-type: none"> 1. Amend $\varnothing 4 \pm 0.3\text{mm}$ to $3.7 \pm 0.2\text{mm}$. 2. Amend $\varnothing 61 \pm 0.3\text{mm}$ to $\varnothing 61 \pm 0.5\text{mm}$. 3. Amend $\varnothing 16.05 \pm 0.2\text{mm}$ to $\varnothing 16 \pm 0.5\text{mm}$. 4. Amend cap material from ABS to POM.

Type of Change

- Hardware Modification
 Production Process Advance
 Others –file change
-

Description of Change

1. Amend $\varnothing 4 \pm 0.3\text{mm}$ to $3.7 \pm 0.2\text{mm}$.
2. Amend $\varnothing 61 \pm 0.3\text{mm}$ to $\varnothing 61 \pm 0.5\text{mm}$.
3. Amend $\varnothing 16.05 \pm 0.2\text{mm}$ to $\varnothing 16 \pm 0.5\text{mm}$.
4. Amend cap material from ABS to POM.

Schedule

2017, August, Taoglas will provide new drawing rule into production.

Forecast Estimated Transition Date

August/2017

Illustration of Change

Old drawing

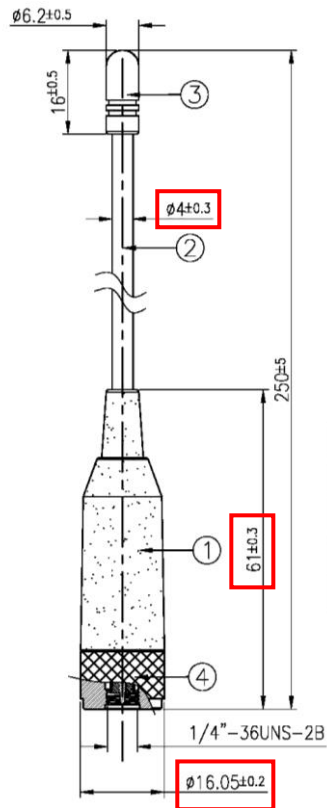

	Name	P/N	Material	Finish	QTY
1	Housing	000111K060002A	ABS	Black	1
2	Flexible Whip	001111K000002A	Steel+PE Jacket	Black	1
3	Cap	000711C000002A	ABS	Black	1
4	Outer Body SMA(M)	000611B000002A	Brass	Black	1

New drawing

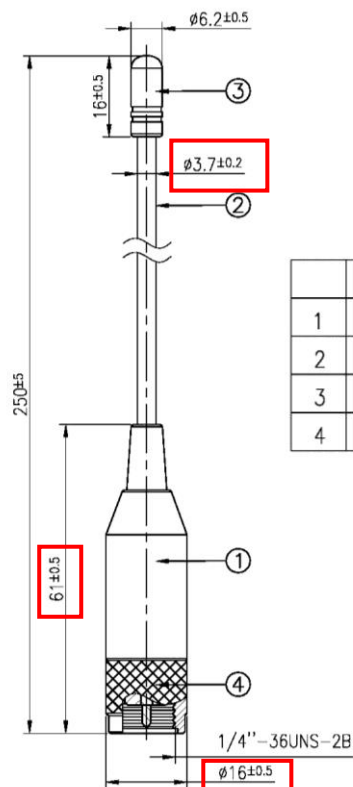

	Name	P/N	Material	Finish	QTY
1	Housing	000111K060002A	ABS	Black	1
2	Flexible Whip	001111K000002A	Steel+PE Jacket	Black	1
3	Cap	000711C000002A	POM	Black	1
4	Outer Body SMA(M)	000611B000002A	Brass	Black	1