

PCN – Process Change Notification

Change:	GSA.8822 Series
Date:	2017/05/08
Author	Haley Tsai

Affected Products

Model#	Part Number	Changes
GSA.8822 Series	-	Amend 11.8±0.9mm to 13±3.1mm.

Type of Change

- Hardware Modification
 Production Process Advance
 Others – Amend 11.8±0.9mm to 13±3.1mm.
-

Description of Change

Amend 11.8±0.9mm to 13±3.1mm.

Schedule

2017, May, Taoglas will provide new drawing into production.

Forecast Estimated Transition Date

May/2017

Illustration of Change

Old drawing

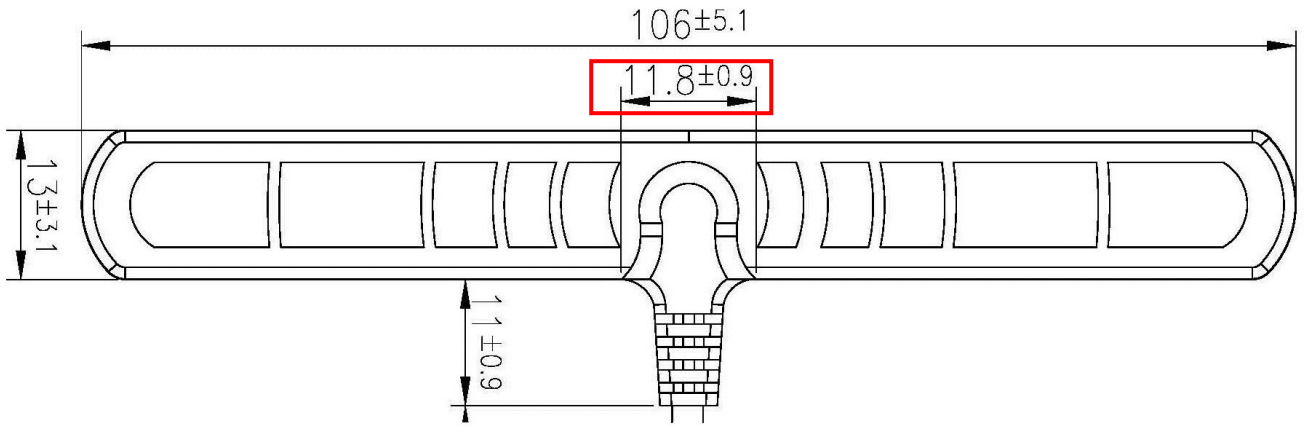

New drawing

