



TAOGLAS®



Datasheet

Part No:
AGGBLA.125.A

Description

Active On-Board SMD Multi-Band GNSS Antenna, covering L1/L5 bands

Features:

Single Stage LNA

Covers Bands

- GPS L1 & L5
- BeiDou B1
- Galileo E1 & E5a
- GLONASS G1
- IRNSS L5

Dimensions: 25 x 25 x 2.8mm

SMD Antenna

RoHS & Reach Compliant

1.	Introduction	2
2.	Specification	3
3.	Antenna Characteristics	5
4.	Radiation Patterns	9
5.	Active Circuitry Characteristics	13
6.	Mechanical Drawing	19
7.	Antenna Integration Guide	20
8.	Packaging	27
<hr/>		
	Changelog	29

Taoglas makes no warranties based on the accuracy or completeness of the contents of this document and reserves the right to make changes to specifications and product descriptions at any time without notice. Taoglas reserves all rights to this document and the information contained herein. Reproduction, use or disclosure to third parties without express permission is strictly prohibited.



1. Introduction



The patent pending AGGBLA.125.A embedded SMD antenna is a next generation, active multi-band GNSS antenna designed to cover working constellations in the GNSS L1/L5 spectrum. The AFXP125 comes with active circuitry, so it is a plug and play alternative to customer's design a complex active circuit themselves. The AFXP.125 multi band GNSS antenna is a compact high precision solution for navigation or asset tracking devices where board space is at a premium and cost is a major factor.

The AGGBLA.125 has an omnidirectional radiation pattern that allows customers to use an omnidirectional antenna in devices where orientation of the product may be unknown, making it less sensitive to device orientation allowing it to be installed in areas where a patch antenna won't work. It also comes with a low noise figure to preserve signal quality helps minimize time to first fix. It also features excellent out-of-band rejection to prevent out-of-band signals from overdriving or damaging its LNAs.

Typical Applications Include:

- E-Mobility
- Precision Agriculture
- Autonomous Vehicles
- UAVs and Robotics

Based on the loop antenna electrical effect, this operates antenna best when placed in the center of the longest edge of the board, the AGGBLA.125.A is an SMD component, delivered on tape and reel. As with all on-board SMD antennas, care must be taken to ensure the device ground-plane layout and antenna matching has been done correctly.

This antenna can be mounted with no performance degradation in either orientation as long as the antenna is soldered correctly via Surface mounting. Please see the integration instructions section for further detail regarding the optimum way to integrate this antenna into your device.

At any of our global design and test facilities, Taoglas can offer professional Gerber review, transmission line design, general integration support and final matching services of the AGGBLA.125.A on your device board. Please contact your regional Taoglas customer support for further information.

2. Specification

GNSS Frequency Bands					
GPS	L1 1575.42 MHz	L2 1227.6 MHz	L5 1176.45 MHz		
	■	□	■		
GLONASS	G1 1602 MHz	G2 1248 MHz	G3 1207 MHz		
	■	□	□		
Galileo	E1 1575.24 MHz	E5a 1176.45 MHz	E5b 1201.5 MHz	E6 1278.75 MHz	
	■	■	□	□	
BeiDou	B1C 1575.42 MHz	B1I 1561 MHz	B2a 1176.45 MHz	B2b 1207.14 MHz	B3 1268.52 MHz
	■	■	■	□	□
L-Band	L-Band 1542 MHz				
	□				
QZSS (Regional)	L1 1575.42 MHz	L2C 1227.6 MHz	L5 1176.45 MHz	L6 1278.75e6	
	■	□	■	□	
IRNSS (Regional)	L5 1176.45 MHz				
	■				
SBAS	L1/E1/B1 1575.42 MHz	L5/B2a/E5a 1176.45 MHz	G1 1602 MHz	G2 1248 MHz	G3 1207 MHz
	■	■	■	□	□

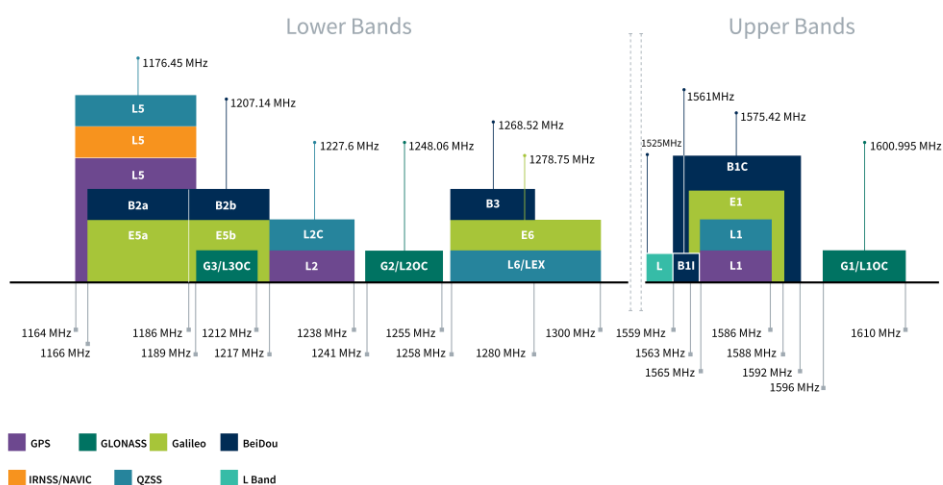

GNSS Bands and Constellations

GNSS Electrical				
Frequency (MHz)	1176.45	1561	1575.42	1603
Return Loss (dB)	-6.3	-6.8	-7.1	-7.1
Passive Antenna Efficiency (%)	75.93	69.05	68.47	66.13
Passive Antenna Gain at Zenith (dBic)	-0.38	-0.95	-0.95	-0.94
Group Delay Mean (ns)	3.42	0.37	0.14	0.71
Polarization		Linear		
Impedance		50 Ω		

LNA and Filter Electrical Properties				
Frequency (MHz)	1176.45	1561	1575.42	1603
Gain@5V (dBic)	17.4	15.4	15.4	15.2
Noise@5V (dBic)	2.4	2.5	2.5	3.0
Current Consumption @5V	10mA			

Total Specification (Through Antenna, SAW Filter and LNA)				
Frequency (MHz)	1176.45	1561	1575.42	1603
Gain@5V (dBic)	14.51	12.5	14.06	14.03
Output Impedance		50 Ω		

Mechanical	
Dimensions	25*25*2.8mm
Weight	9g
Material	FR4

Environmental	
Temperature Range	-40°C to 85°C
Moisture Sensitivity Level (MSL)	3 (168 Hours)

3. Antenna Characteristics

3.1 Test Setup

AUT



Vector Network Analyzer

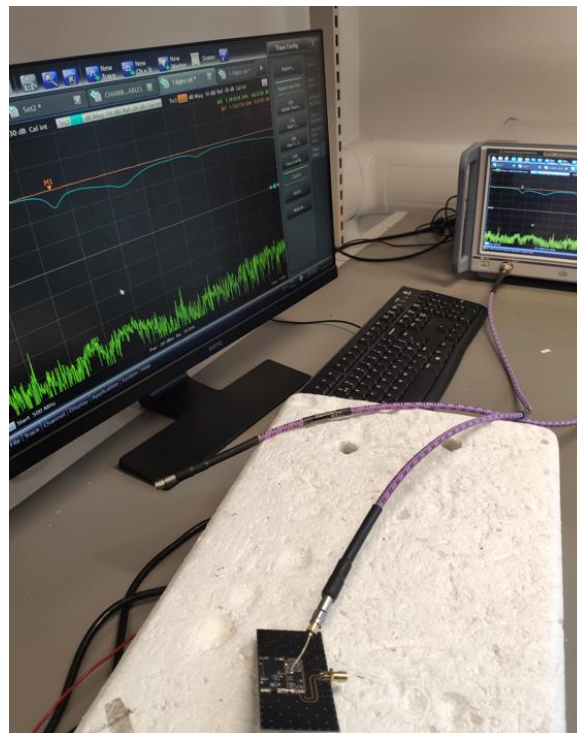

3.2 Return Loss

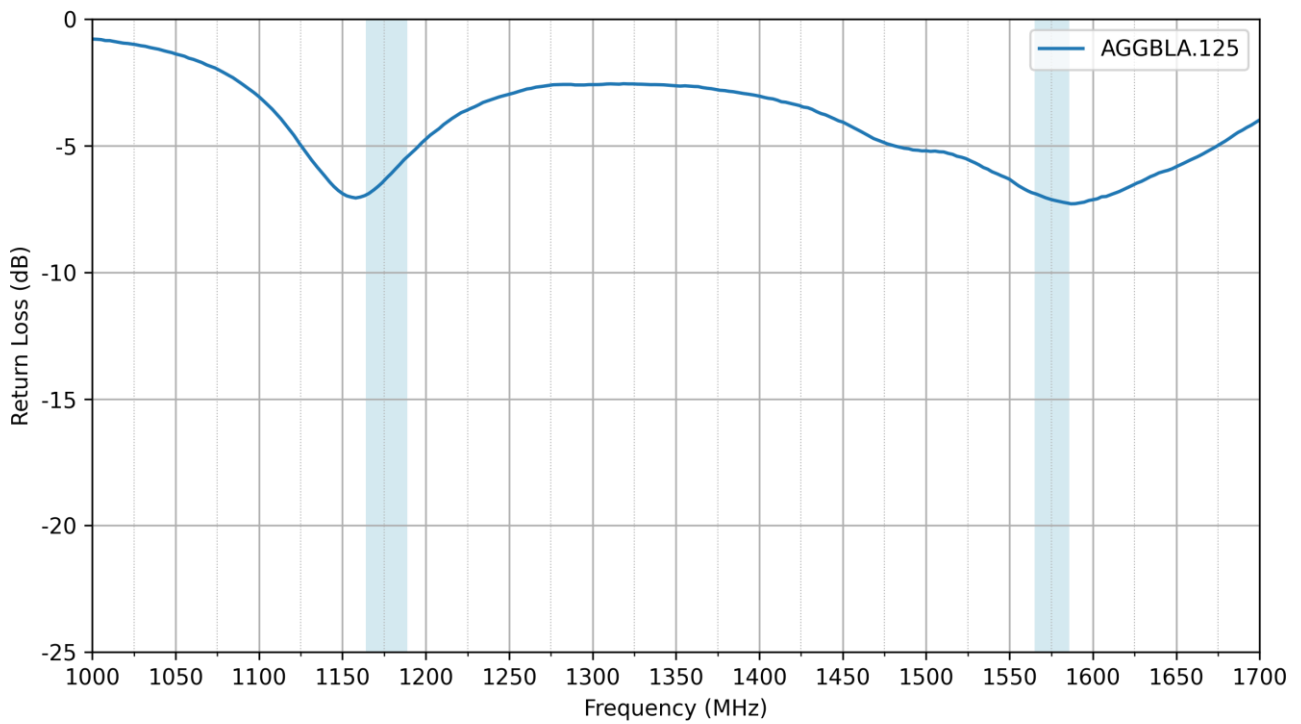

3.3 VSWR

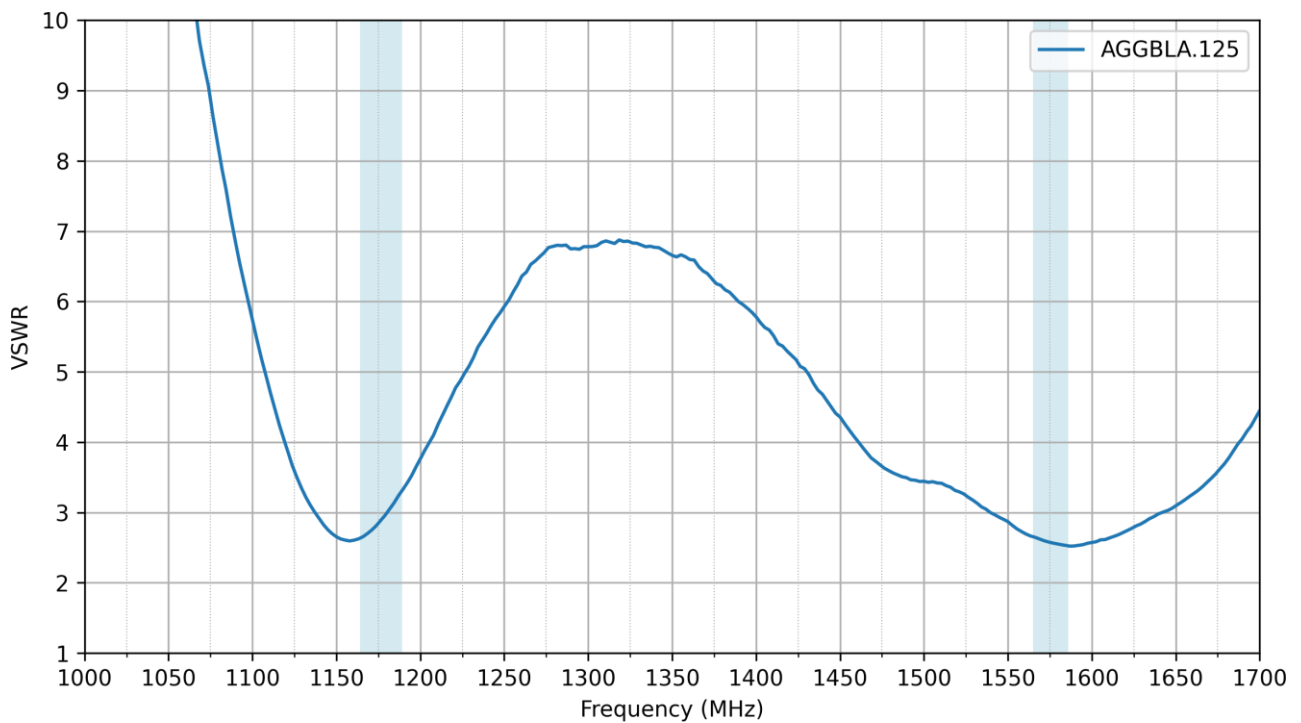

3.4 Efficiency

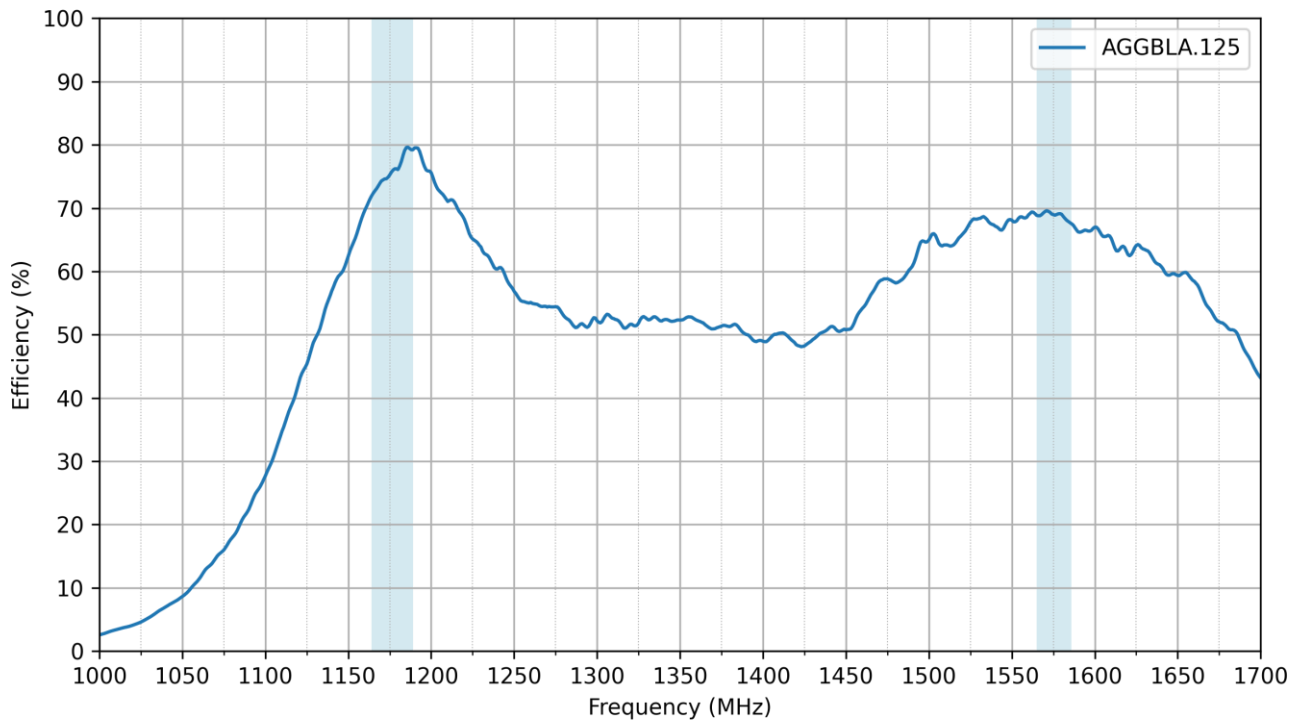

3.5 Average Gain

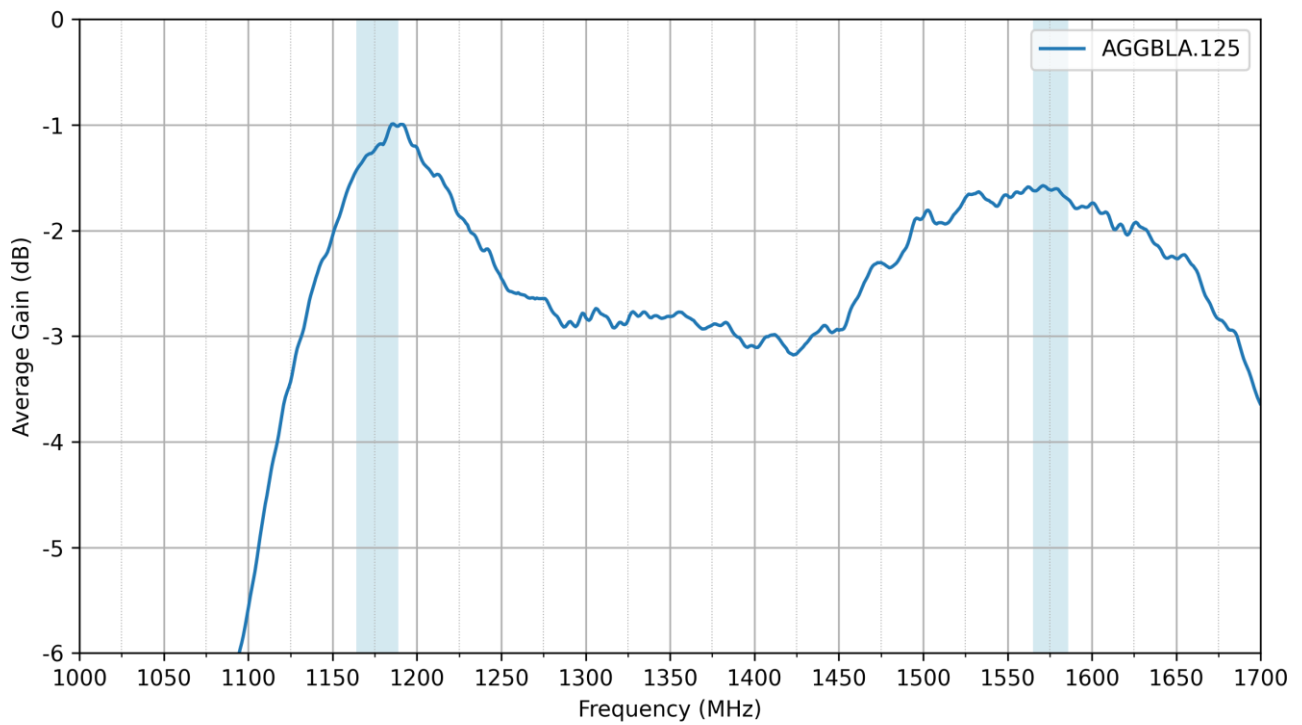

3.6 Peak Gain

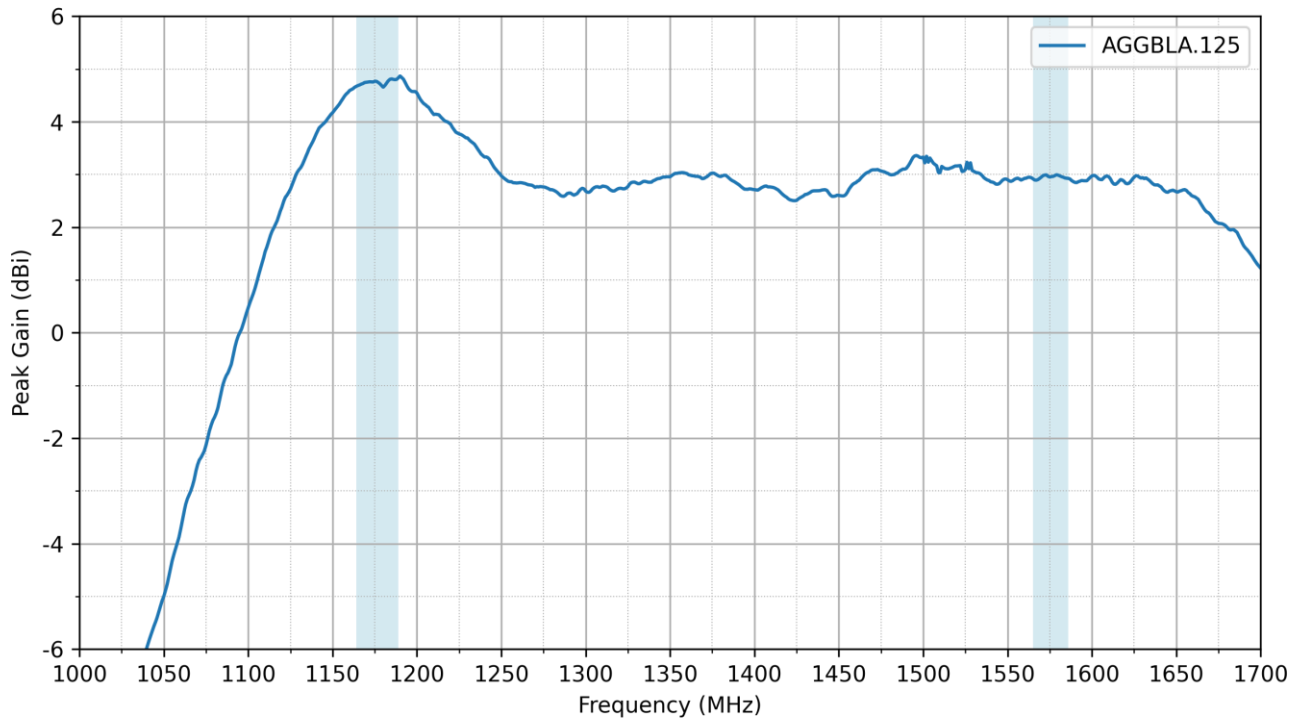

4. Radiation Patterns

4.1 Test Setup

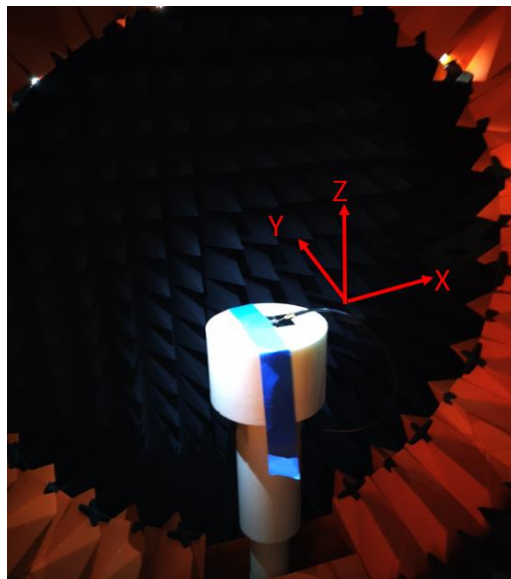
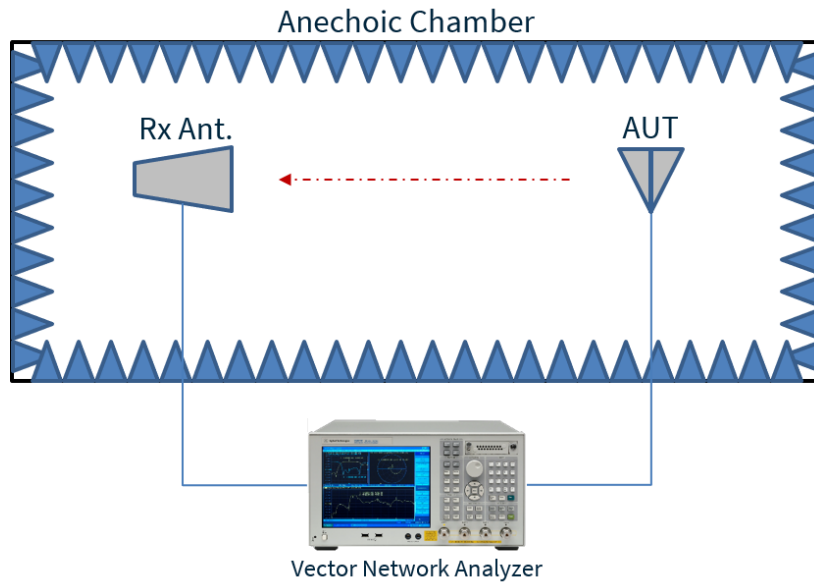

4.2 AGGBLA.125 Patterns at 1176 MHz

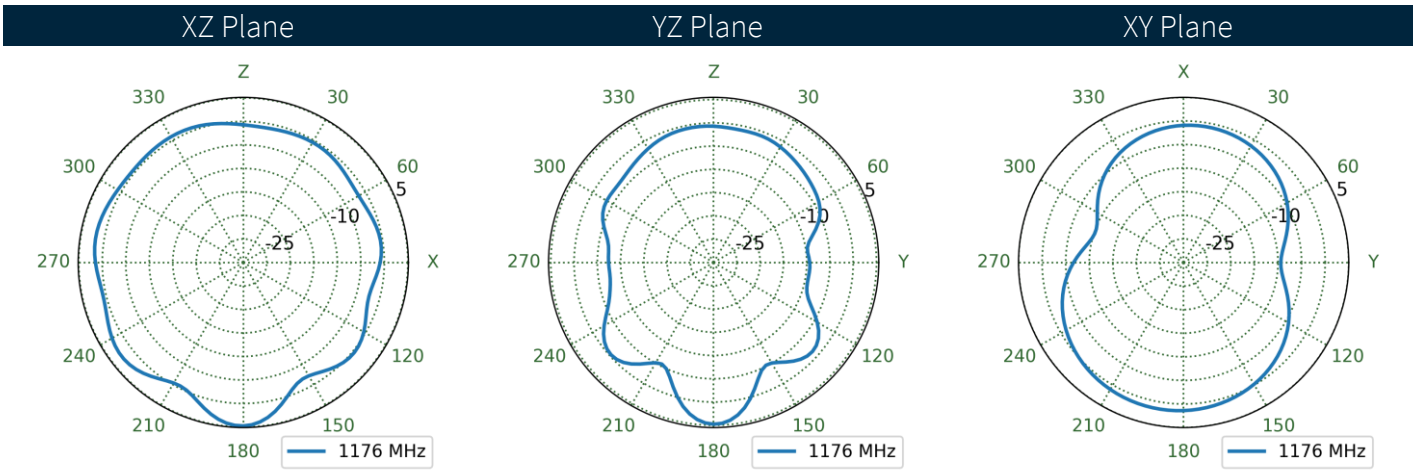
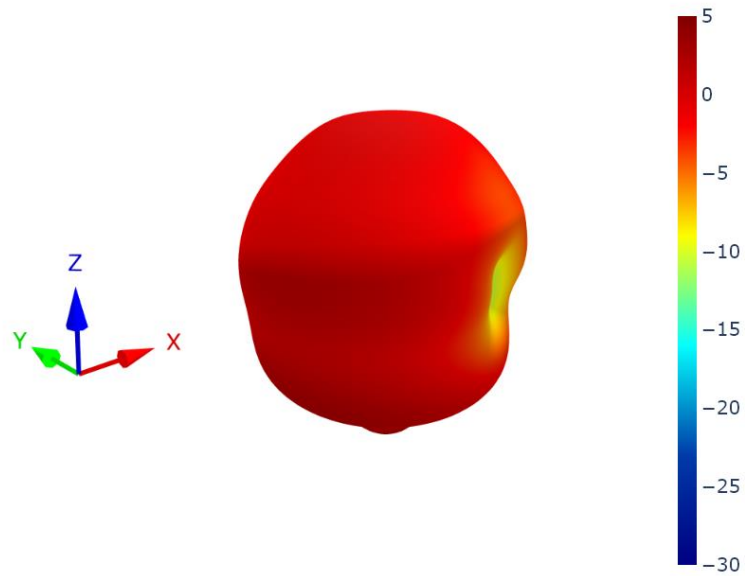

4.3 AGGBLA.125 Patterns at 1575 MHz

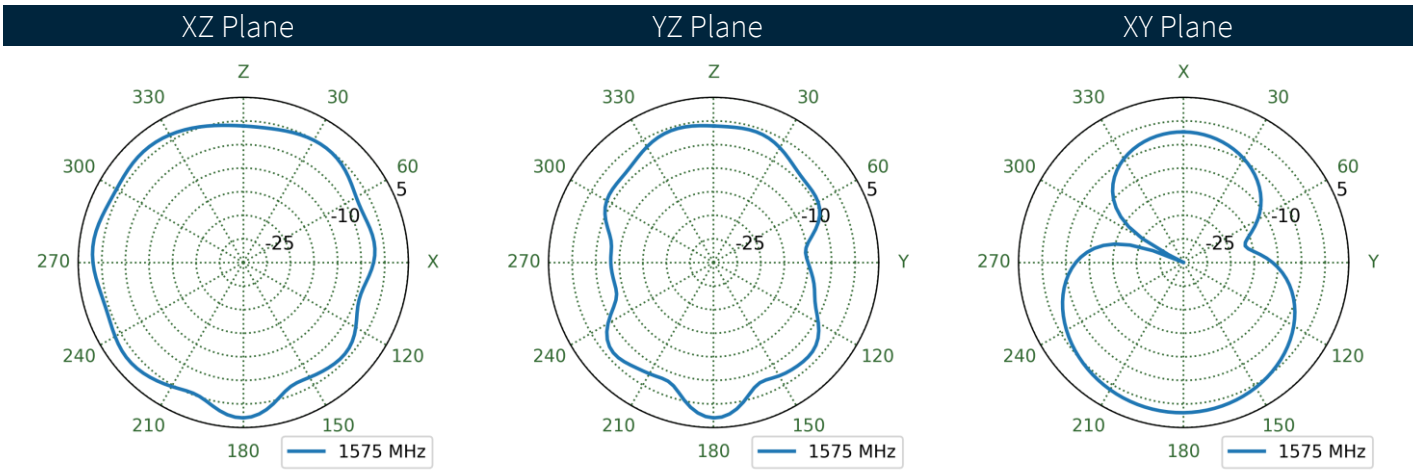
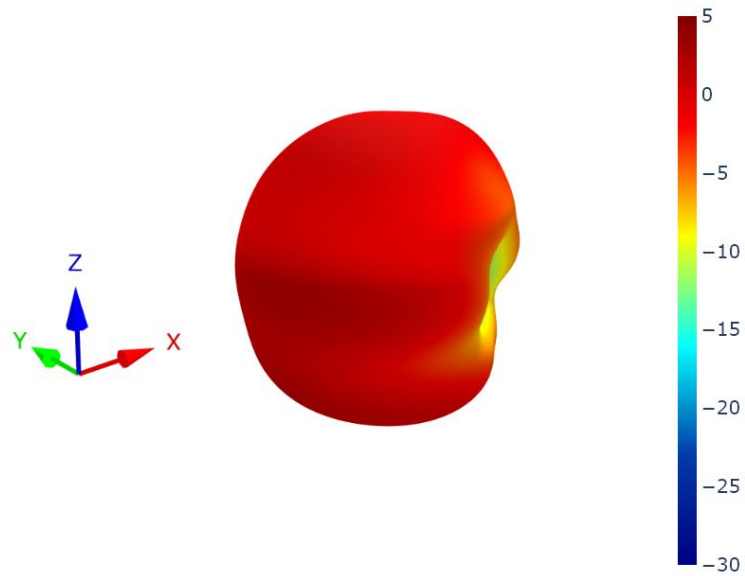

4.4 AGGBLA.125 Patterns at 1603 MHz

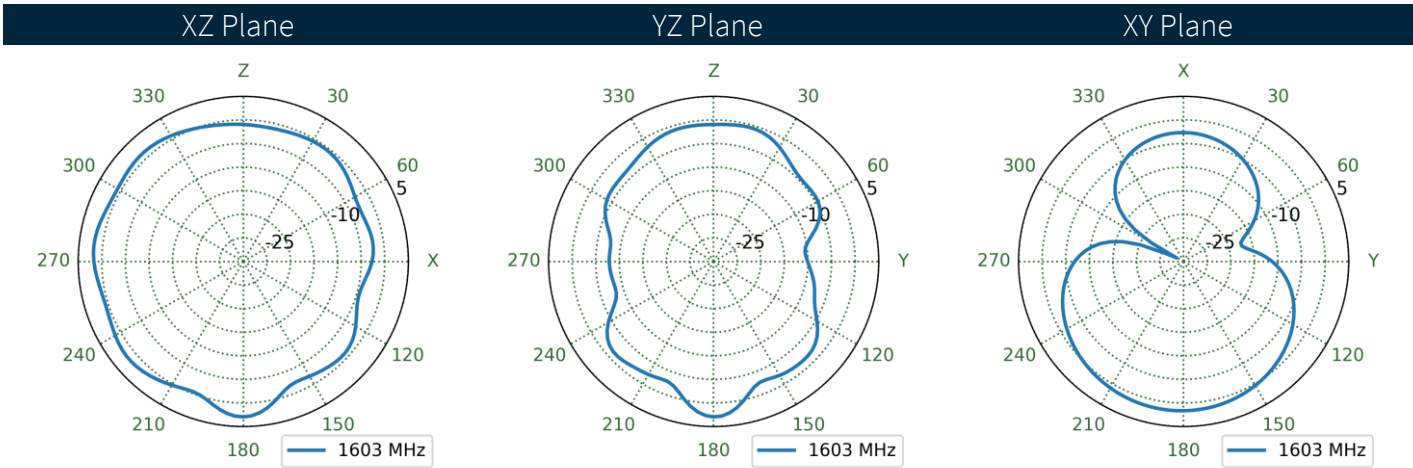
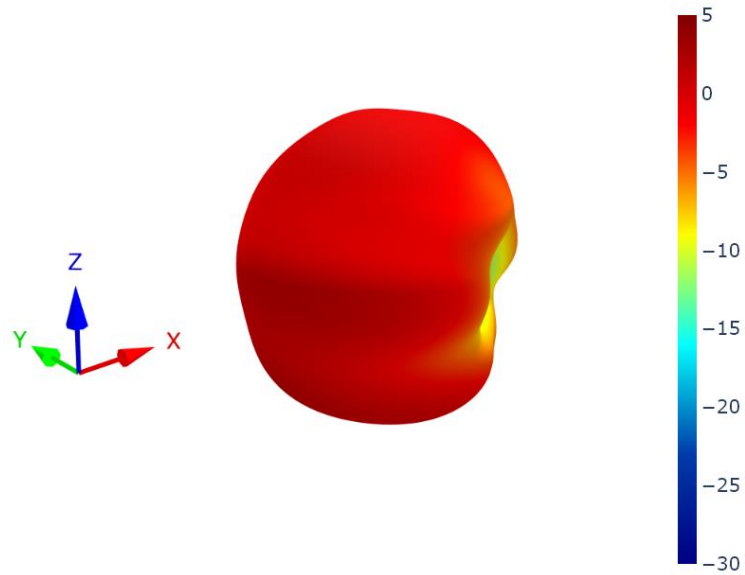

5. Active Circuitry Characteristics

5.1 Block Diagram

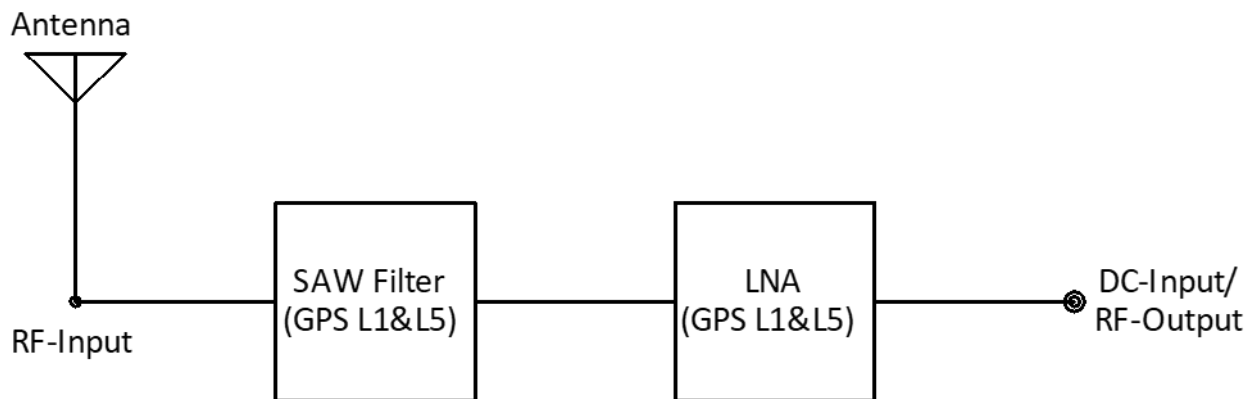

5.2 LNA Gain L1 & L5

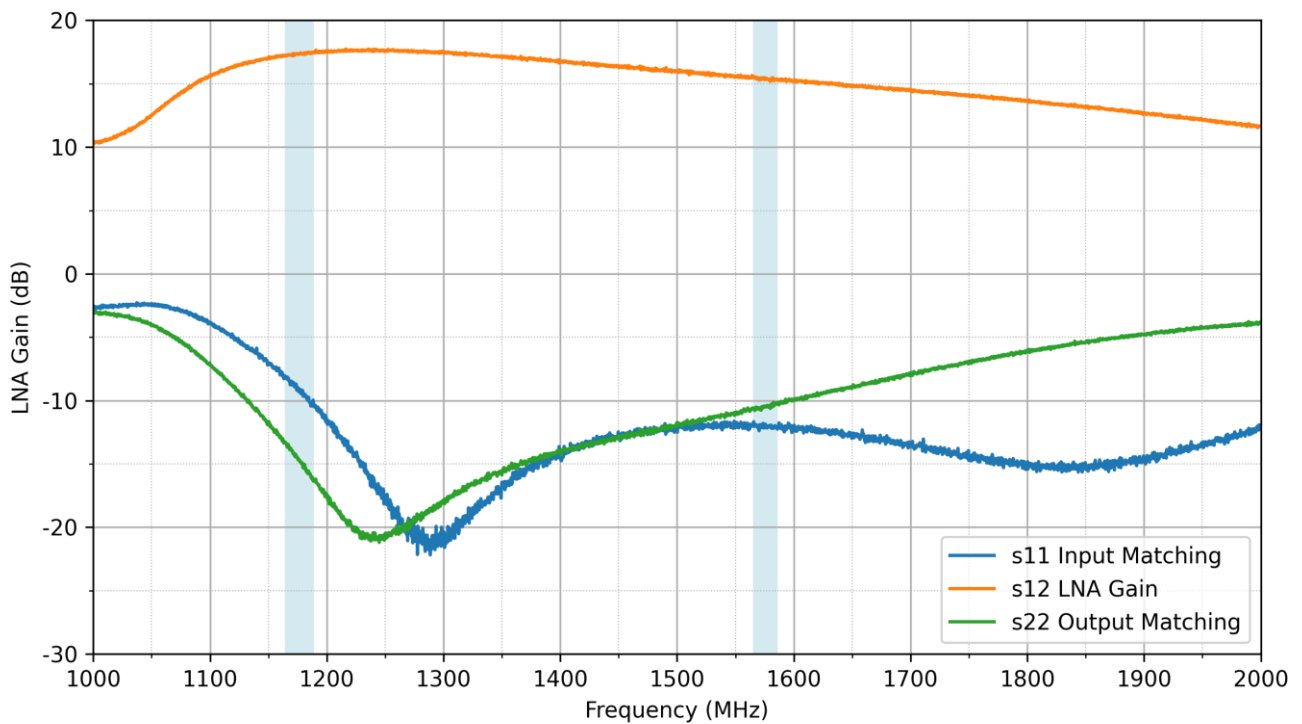

5.3 P1dB Compression Point (L1)

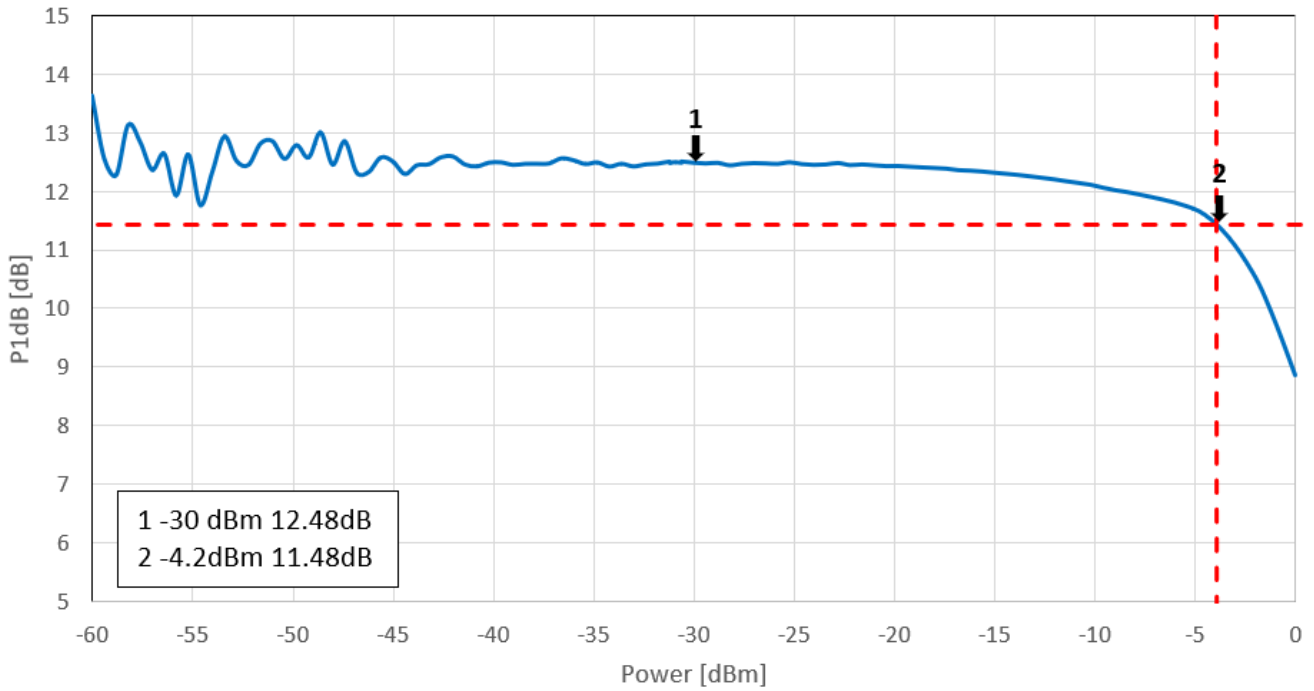

5.4 P1dB Compression Point (L5)

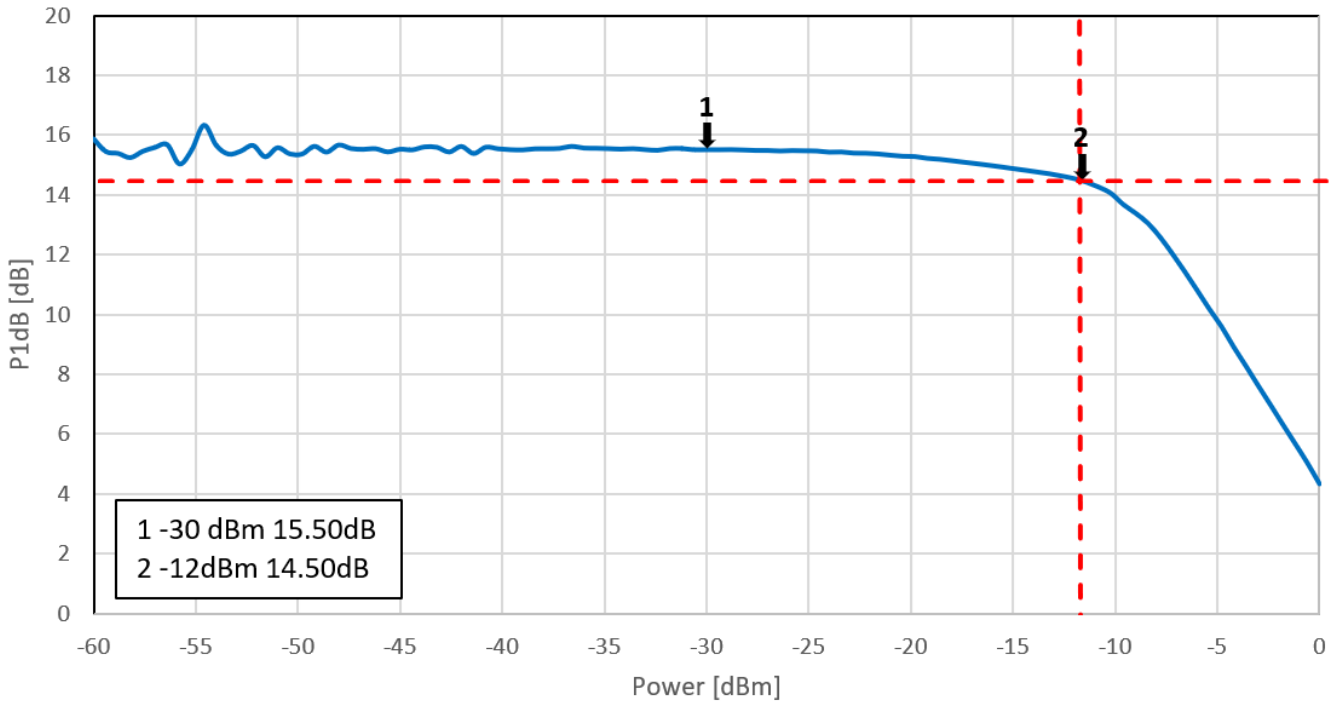

5.5 Noise Figure (L1)

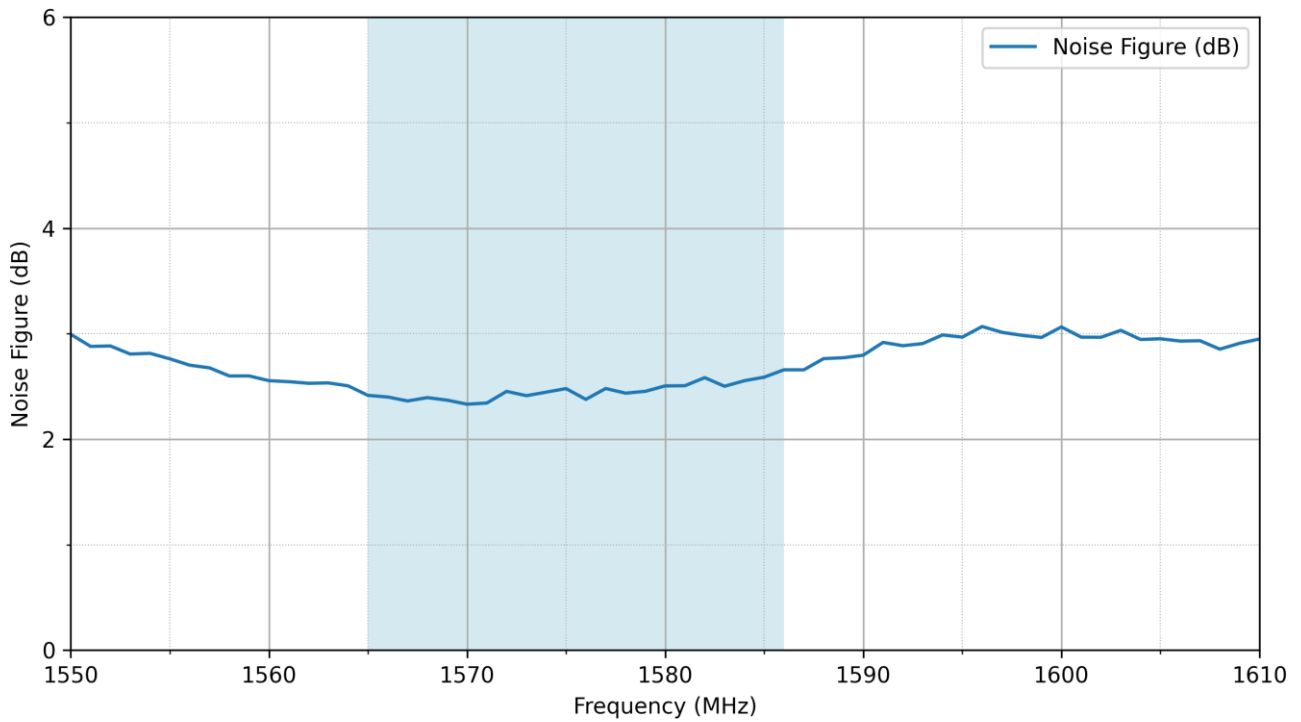

5.6 Noise Figure (L5)

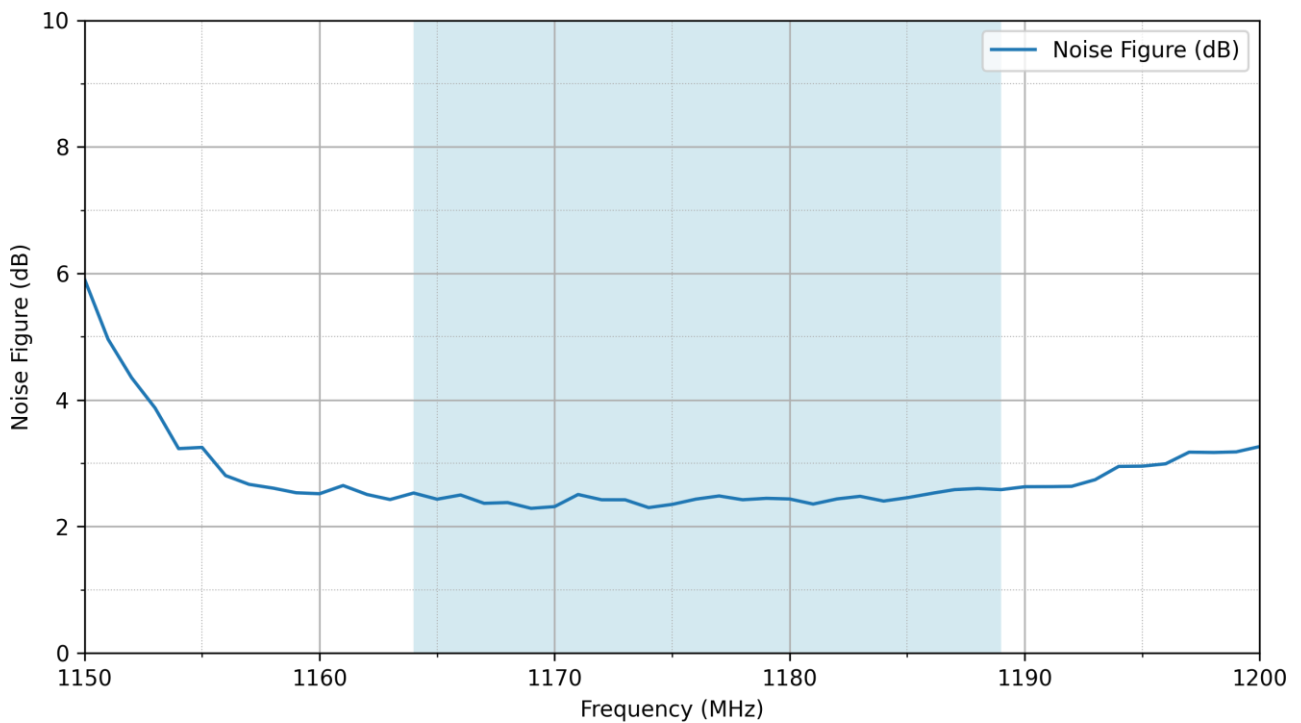

5.7 Group Delay (L1)

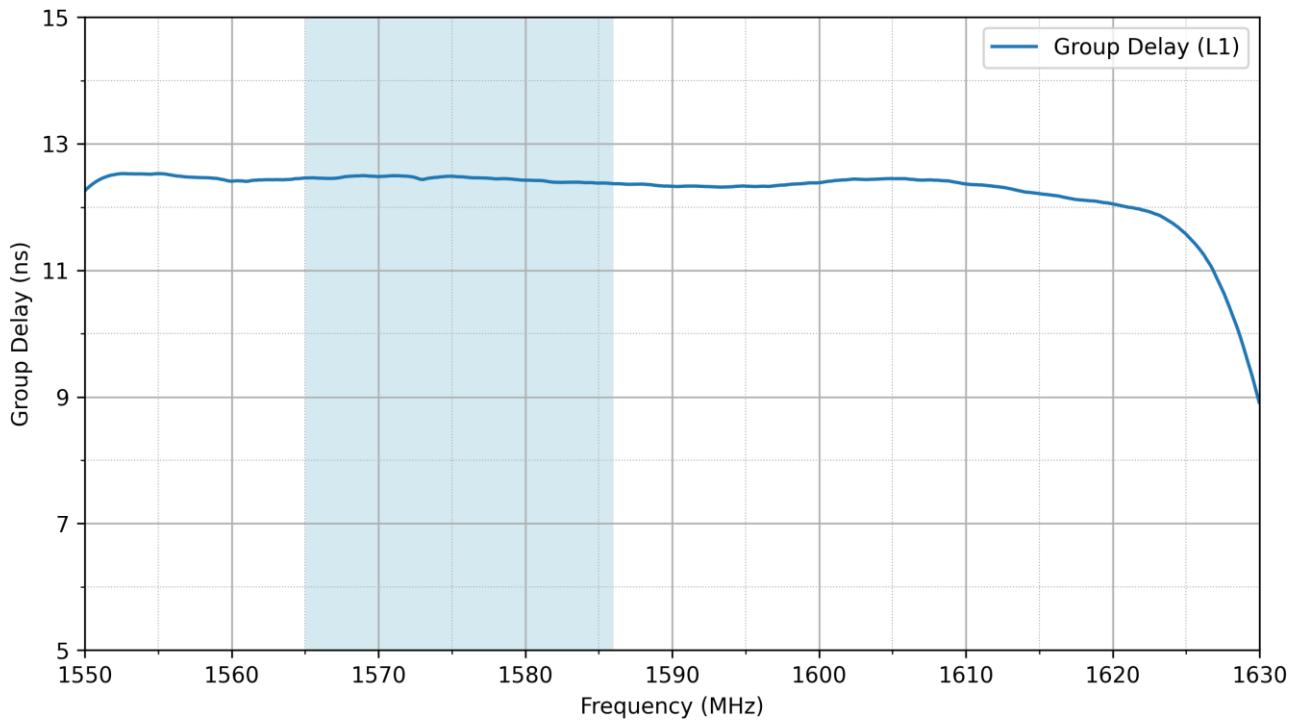

5.8 Group Delay (L5)

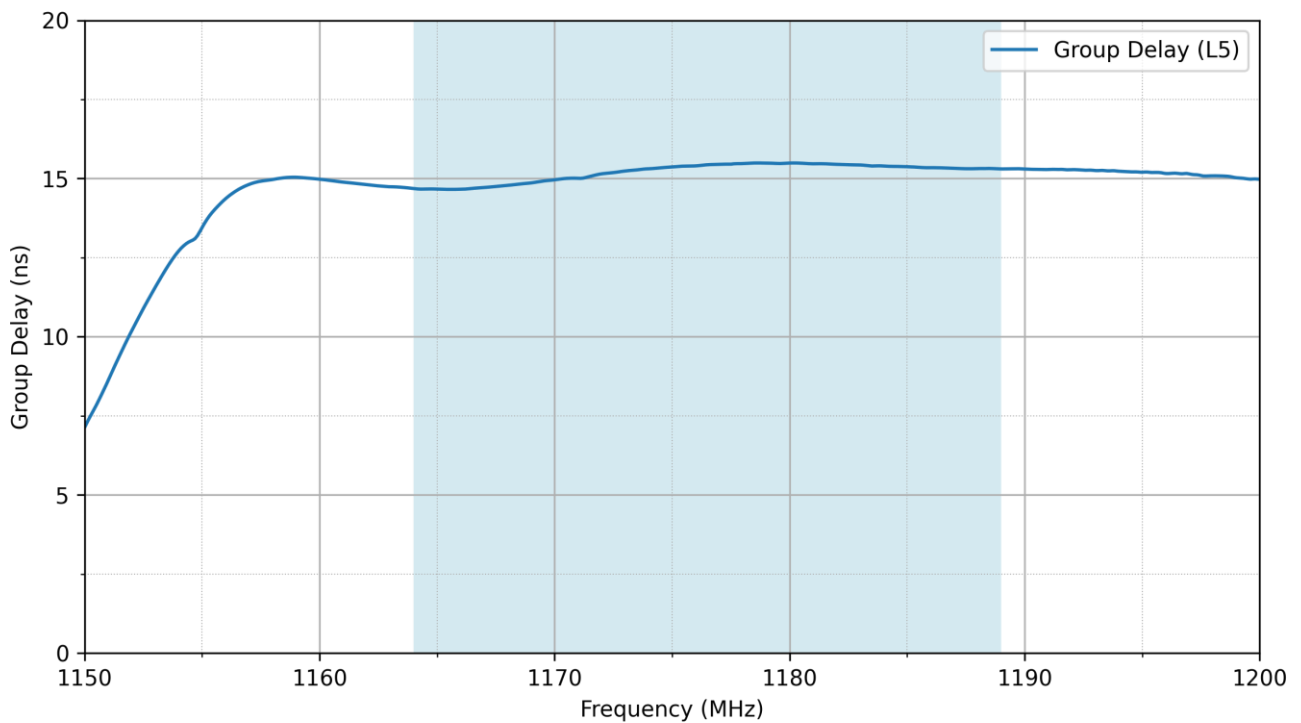

5.9 L1/L5 Dual Band Saw Filter Performance

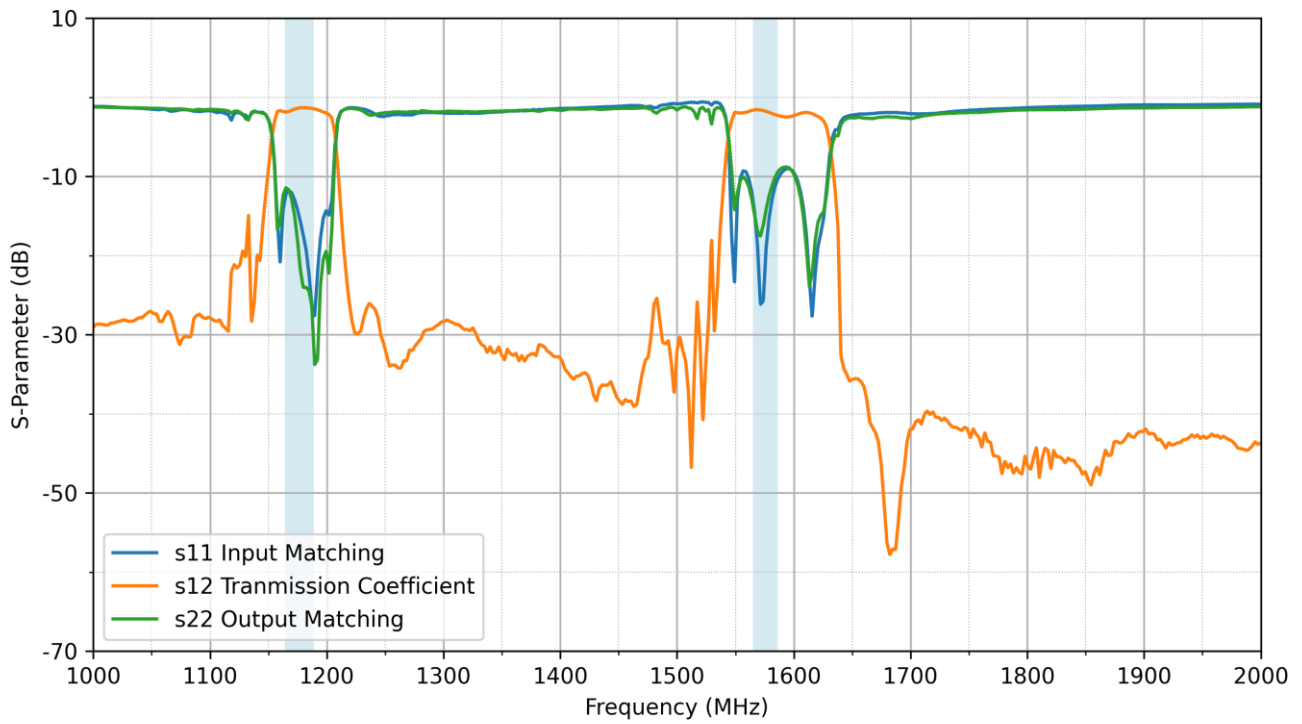

5.10 Out Of Band Rejection

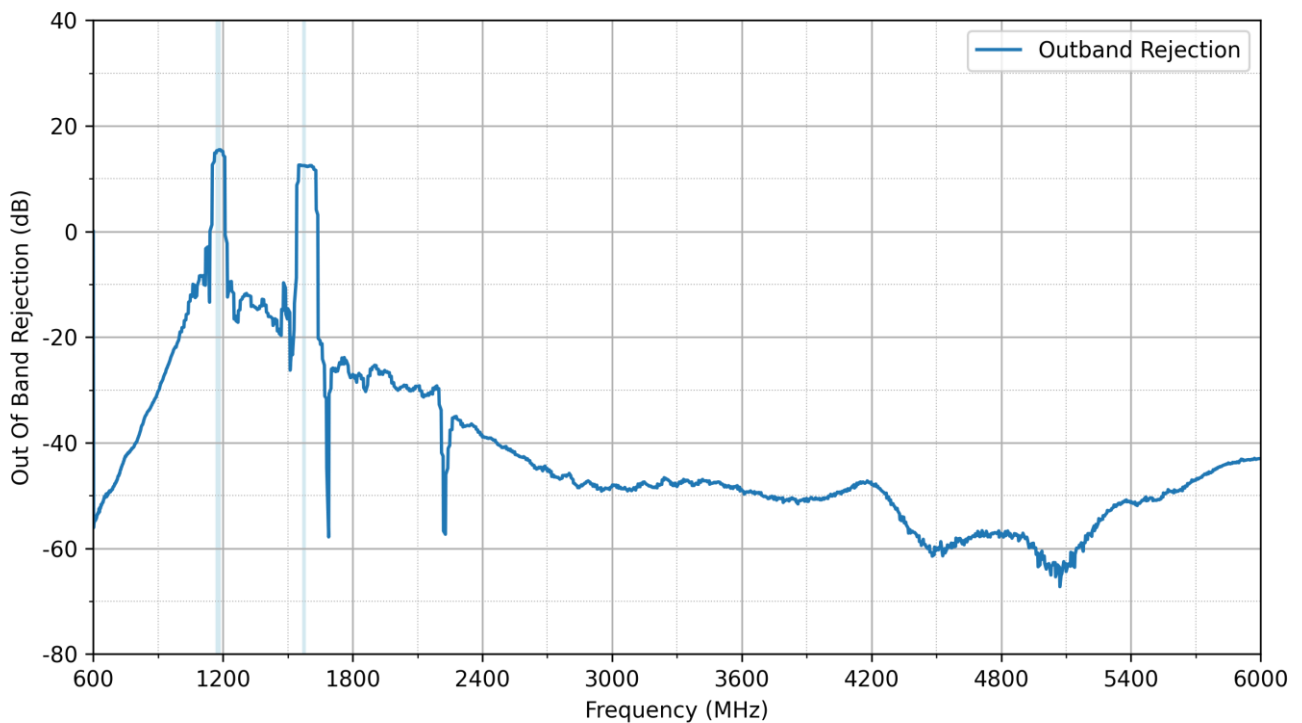

5.11 Combined Gain

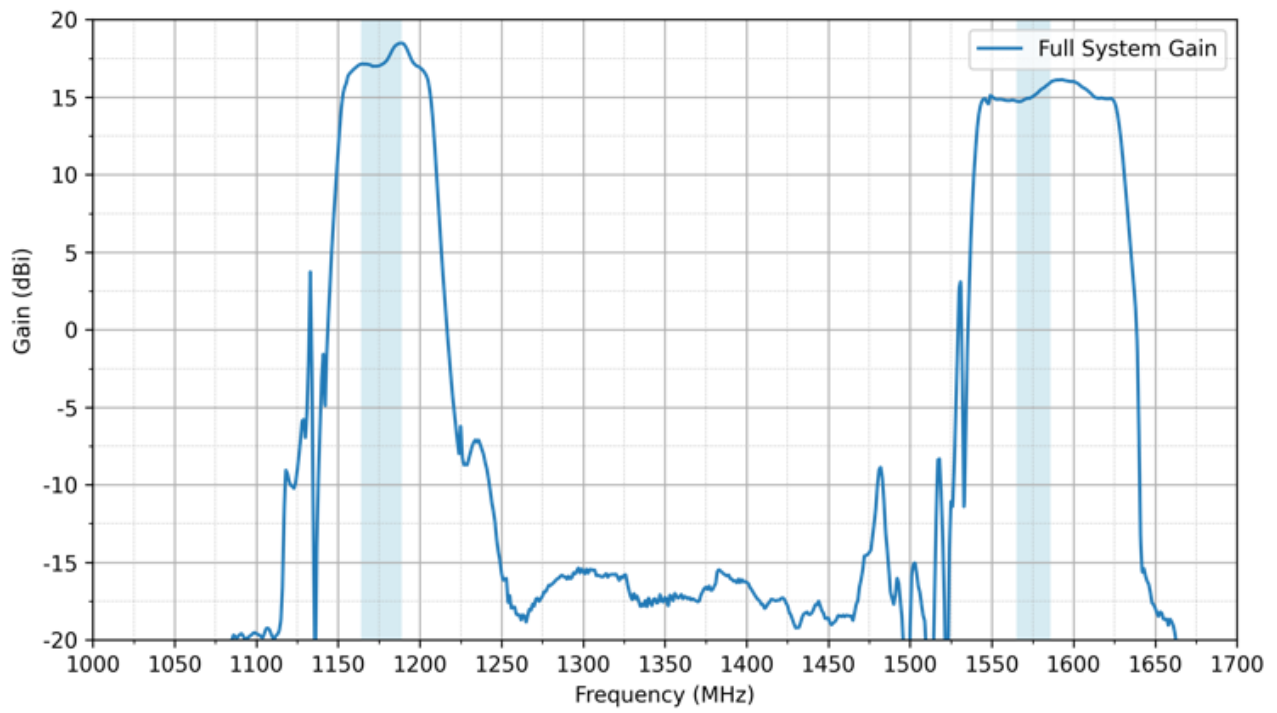

6. Mechanical Drawing

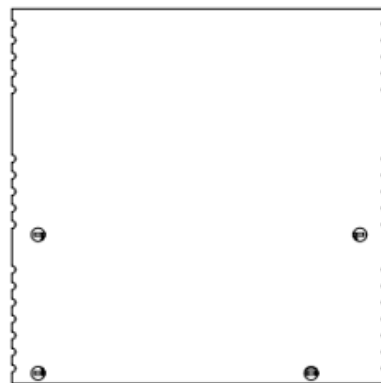
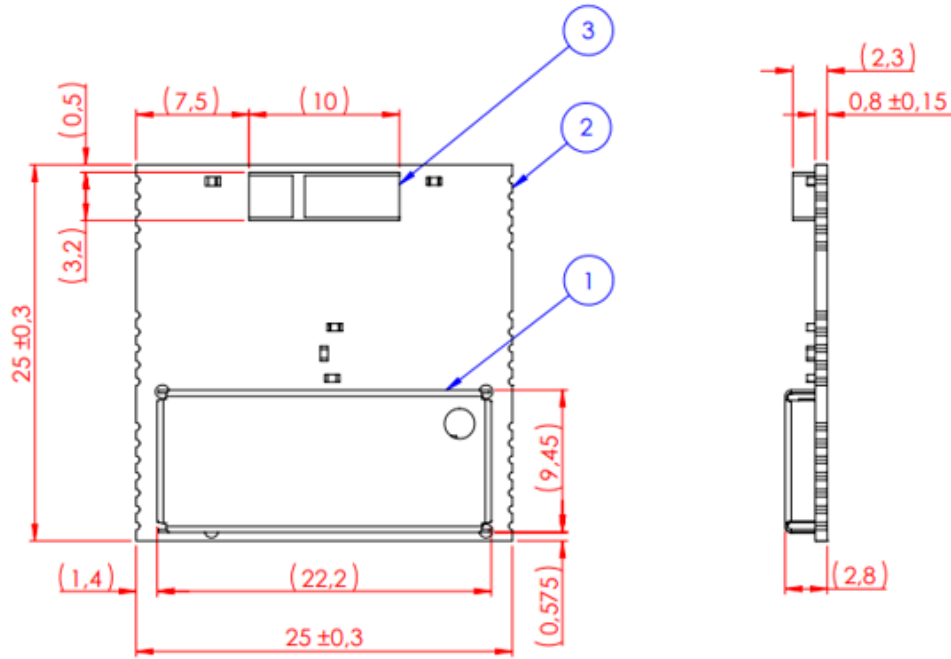

ITEM NO.	DESCRIPTION	QTY
1	SHIELDING CASE SPTe TIN PLATED	1
2	GGBLA.125.A GNSS ANTENNA PCBA/SMDP	1
3	GPS/GLONASS/GALILEO/BEI-DOU CERAMIC SUBSTRATE LOOP ANTENNA (L/E 1, 2, 5)	1

7. Antenna Integration Guide

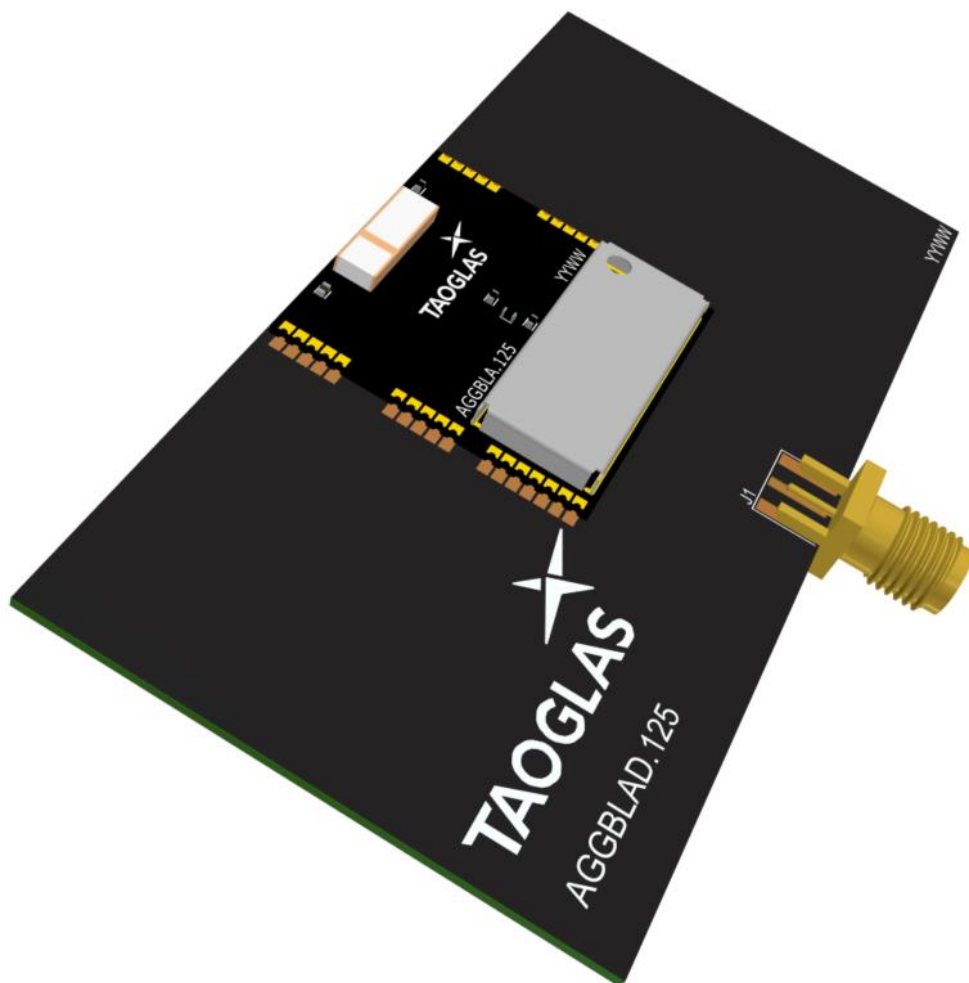
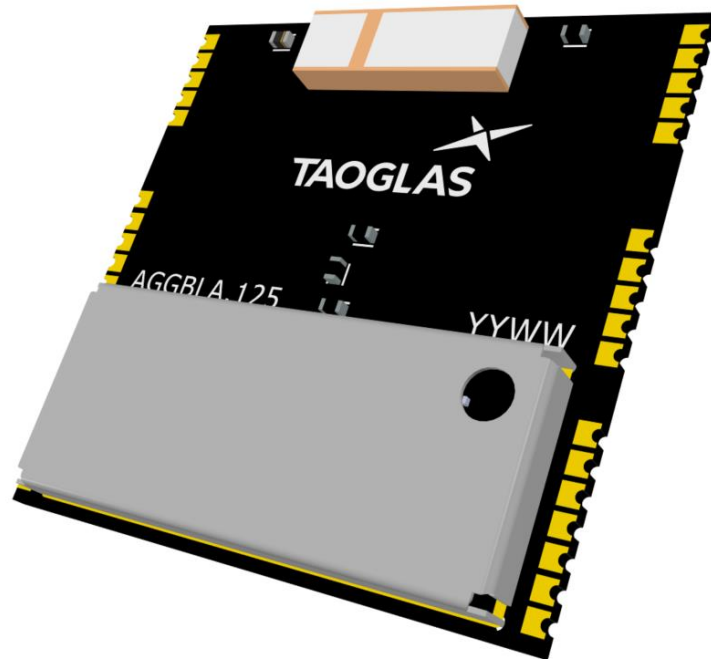

7.1 Schematic Symbol and Pin Definitions

The circuit symbol for the antenna is shown below. The antenna has 34 pins with all pins as functional.

Pin	Description
1	RF Feed
2-34	Ground

TAOGLAS_AGGBLA.125 ANT1

1	RF FEED	GND	34
2	GND	GND	33
3	GND	GND	32
4	GND	GND	31
5	GND	GND	30
6	GND	GND	29
7	GND	GND	28
8	GND	GND	27
9	GND	GND	26
10	GND	GND	25
11	GND	GND	24
12	GND	GND	23
13	GND	GND	22
14	GND	GND	21
15	GND	GND	20
16	GND	GND	19
17	GND	GND	18

7.2 Antenna Integration

For any given PCB size, the antenna should ideally be placed on the PCB's longest side, to take advantage of the ground plane. Optimized matching components can be placed as shown.

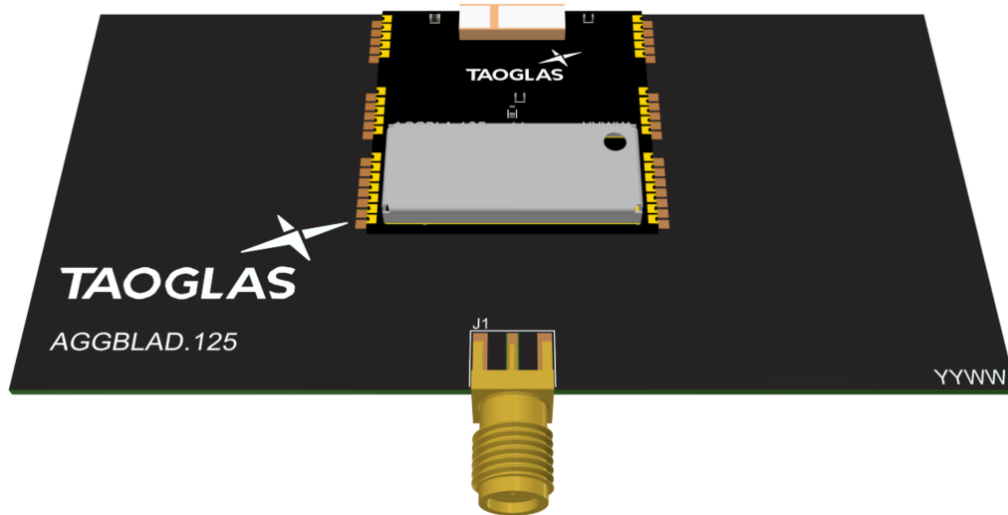

With Solder Mask

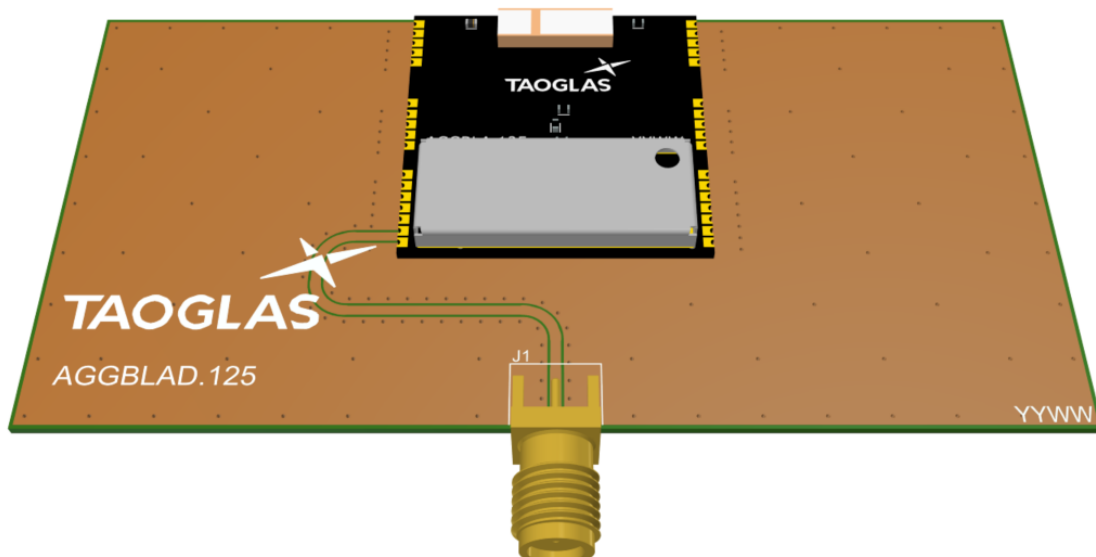

Without Solder Mask

7.3 PCB Layout

The footprint and clearance on the PCB must meet the layout drawing in section

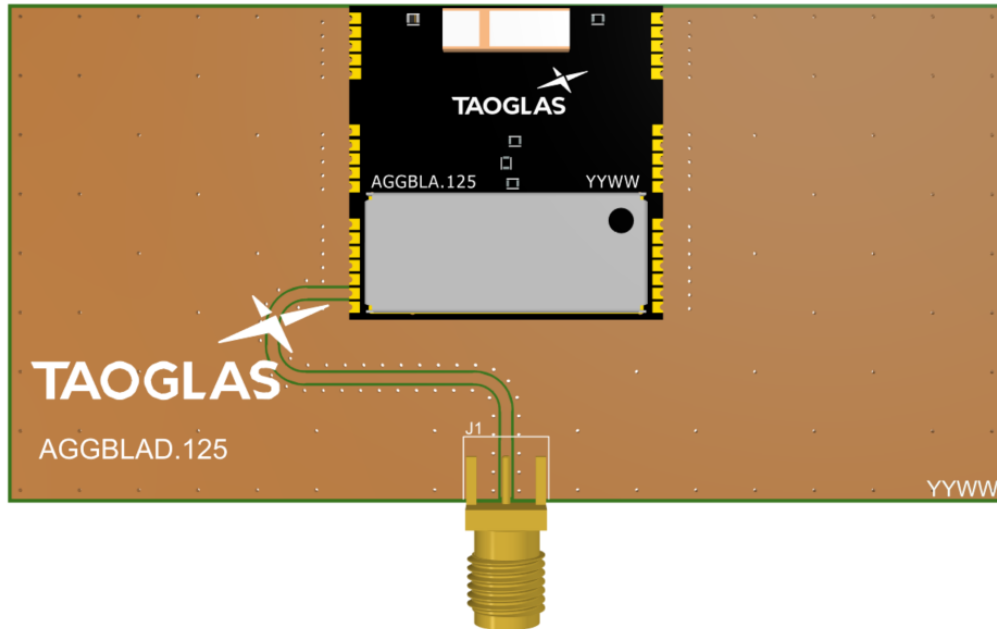

With Antenna

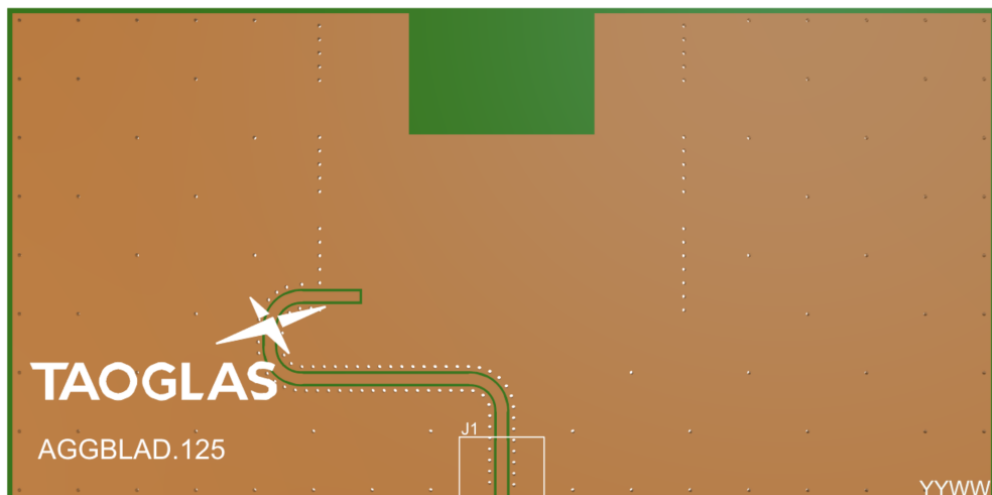

Without Antenna

7.4 PCB Clearance

Below shows the antenna footprint and clearance through ALL layers on the PCB. Only the antenna pads and connections to feed and GND are present within this clearance area (marked RED). The clearance area extends to 10.1mm in length and 15mm in width from the centre of the top side of the PCB. This clearance area includes the bottom side and ALL internal layers on the PCB.

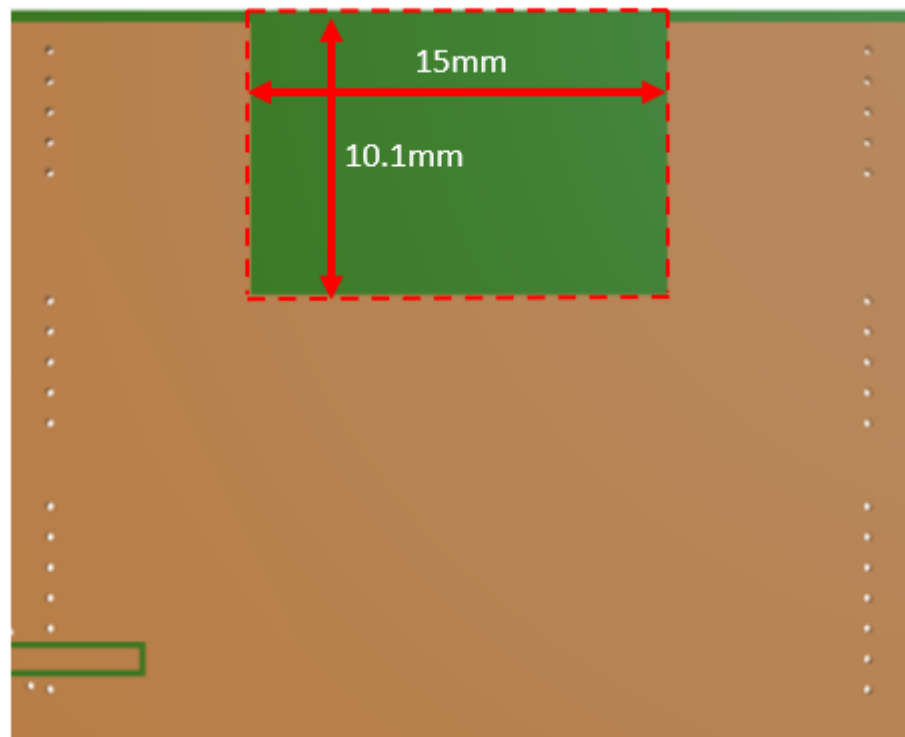

7.5 PCB Clearance

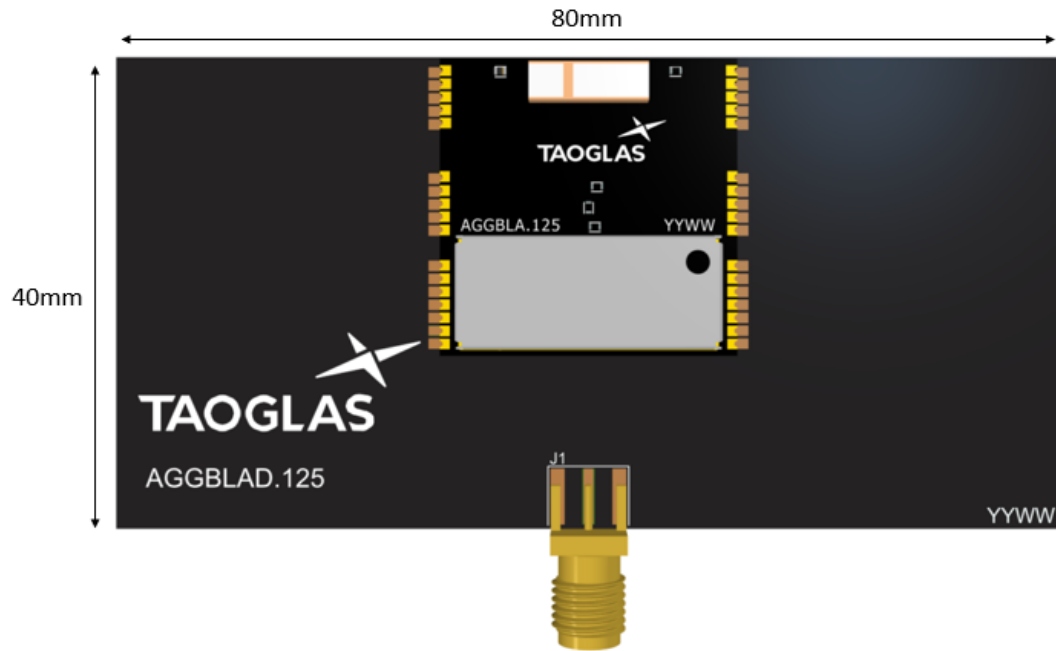

Topside



Bottom Side

7.6 Footprint

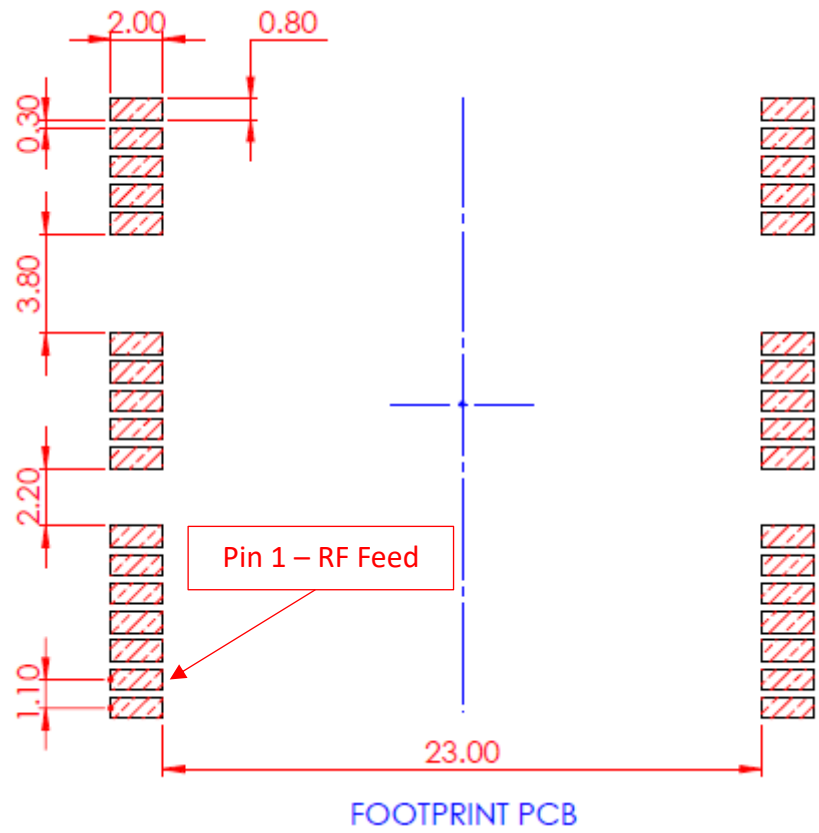

8. Packaging

1000 pcs AGGBLA.125 per Tape & Reel

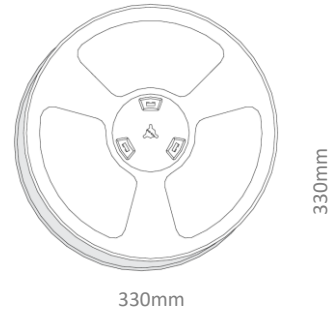

1 reel in small inner box
 Dimensions: 350*340*70mm
 Weight: 2.2Kg

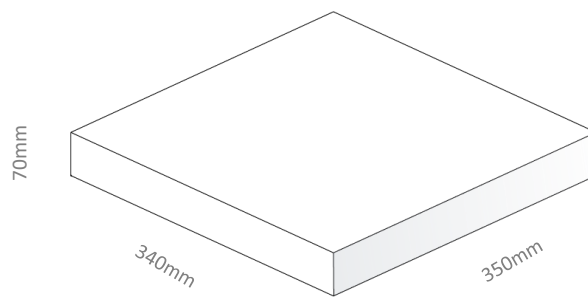

4000 pcs in one carton
 Dimensions: 370*370*300mm
 Weight: 8.9Kg

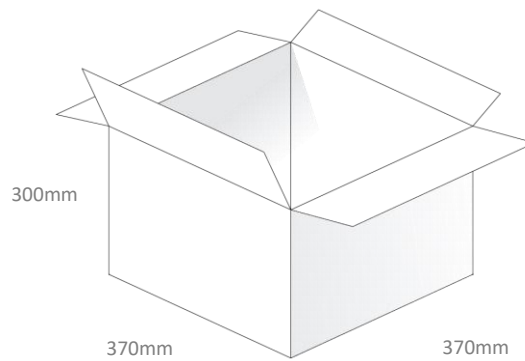

Changelog for the datasheet

SPE-23-8-240– AGGBLA.125

Revision: A (Original First Release)	
Date:	2023-08-24
Notes:	Initial Release
Author:	Gary West

Previous Revisions



www.taoglas.com

