



TAOGLAS®



Datasheet

Active L1, L2, L-Band GNSS High Precision Antenna

Part No:
AHP24510.07.0100C

Description

Active L1/L2/L-Band GNSS Antenna
45x45x10mm Dual Feed Stacked Patch

Features:

L1, L2, L-Band GNSS Bands Covered
Ceramic Patch Element
Cable: 100mm ϕ 1.13
Connector: IPEX MHFI (U.FL)
Dimensions: 45x45x10mm
RoHS & Reach Compliant

1.	Introduction	2
2.	Specification	3
3.	Antenna Characteristics	6
4.	Radiation Patterns	10
5.	LNA Characteristics	20
6.	Mechanical Drawing	24
7.	Packaging	25
<hr/>		
	Changelog	25

Taoglas makes no warranties based on the accuracy or completeness of the contents of this document and reserves the right to make changes to specifications and product descriptions at any time without notice. Taoglas reserves all rights to this document and the information contained herein. Reproduction, use or disclosure to third parties without express permission is strictly prohibited.



1. Introduction



The Taoglas AHP24510, is a multi-band GNSS, high-performance directional antenna for high precision GPS and BeiDou accuracy and fast positioning. It utilizes a 45*45*10mm advanced wide-band dual stacked ceramic patch antenna with optimized gain for GPS L1/L2, Galileo, GLONASS, BeiDou, and L-Band bands.

Typical Applications Include:

- Wearables
- Transportation
- Precision Agriculture
- Navigation
- Robotics
- Autonomous Vehicles

The AHP24510 has been tuned and tested on a 60 x 60 mm ground plane and exhibits excellent radiation patterns. The AHP24510 has been optimized to cover the bands required for the next generation of L1/L2 GNSS receivers that are currently on the market. It is supplied with 4 corner screw holes for easy installation in customer devices.

The AHP24510 has been designed to be a premium solution for high precision GNSS systems, by including the L-Band for High Precision GNSS correction services. The L-Band correction service is utilized in High Precision GNSS systems to decode the satellite transmission and outputs a correction stream, enabling a high precision system to reach genuine centimeter level accuracy.

The cable and connector is fully customizable, for further information please contact your regional Taoglas customer support team to request these services or additional support to integrate and test this antenna's performance in your device.

2. Specification

GNSS Frequency Bands					
GPS	L1 1575.42 MHz	L2 1227.6 MHz	L5 1176.45 MHz		
	■	■	□		
GLONASS	G1 1602 MHz	G2 1248 MHz	G3 1207 MHz		
	■	■	■		
Galileo	E1 1575.24 MHz	E5a 1176.45 MHz	E5b 1201.5 MHz	E6 1278.75 MHz	
	■	□	■	□	
BeiDou	B1C 1575.42 MHz	B1I 1561 MHz	B2a 1176.45 MHz	B2b 1207.14 MHz	B3 1268.52 MHz
	■	■	□	■	□
L-Band	L-Band 1542 MHz				
	■				
QZSS (Regional)	L1 1575.42 MHz	L2C 1227.6 MHz	L5 1176.45 MHz	L6 1278.75e6	
	■	■	□	□	
IRNSS (Regional)	L5 1176.45 MHz				
	□				
SBAS	L1/E1/B1 1575.42 MHz	L5/B2a/E5a 1176.45 MHz	G1 1602 MHz	G2 1248 MHz	G3 1207 MHz
	■	□	■	■	■

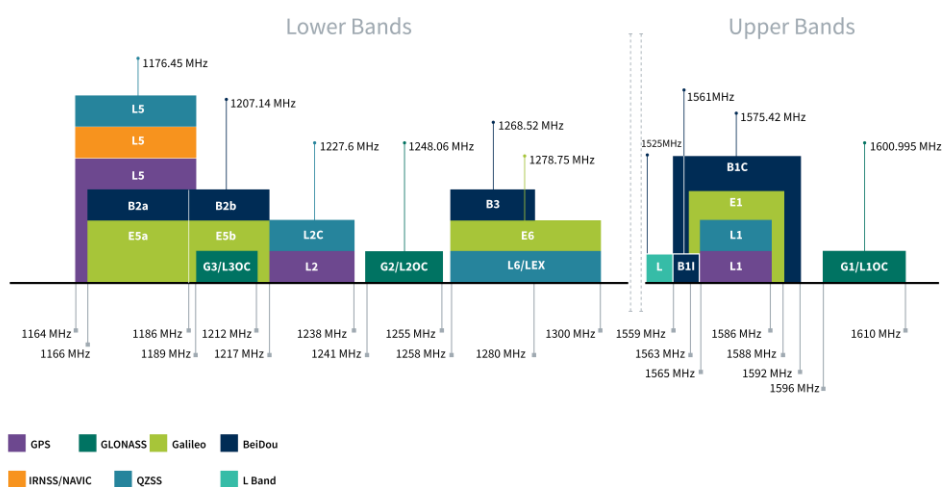

GNSS Bands and Constellations

GNSS Electrical							
Frequency (MHz)	1207	1227.6	1248	1525-1559	1561	1575.42	1603
VSWR (max.)	1:1	1:1	1:1	1:1	1:1	1:1	1:1
Passive Antenna Efficiency (%)	39.93	61.54	45.47	55.72	68.52	69.41	61.1
Passive Antenna Gain at Zenith (dBic)	1.23	3.48	2.95	4.01	4.21	4.43	4.27
Axial Ratio (dB)	1.84	0.54	1.31	0.5	0.7	0.84	0.95
PCO (cm)	3.4	3.4	3.0	1.9	1.9	2.0	2.2
PCV (cm)	0.6	0.6	0.6	0.3	0.2	0.2	0.2
Group Delay Mean (ns)	11.58	12.94	13.58	10.29	10.98	11.01	11.11
Group Delay Variation (ns)	3	6	3	0	1	2	0
Polarization	RHCP						
Radiation Pattern	Directional						
Impedance	50 Ω						

*Tested on a 70x70mm Ground plane

LNA and Filter Electrical Properties							
Frequency (MHz)	1207	1227.6	1248	1525-1559	1561	1575.42	1603
Noise Figure (dB)	2.0	2.3	2.4	2.4	2.1	1.8	2.3
Gain (dB)	29.2	29.4	28.6	28.8	28.5	28.3	26.9
Input Voltage (V)	+ 1.8 to 5.5						
Current consumption (mA)	18 \pm 3						
Outer Band Attenuation (dB)	> 65dB @ LTE Band						

Mechanical	
Dimensions	45x45x5.1mm
Total Dimension (Including Shielding Case)	60x60mm
Connector	IPEX MHFI (U.FL)
Cable	1.37mm Coaxial Cable
Material	Ceramic
Weight	70g

Environmental	
Temperature Range	-40°C to 85°C
Storage Temperature	-40°C to 85°C
Humidity	Non-condensing 65°C 95% RH

3. Antenna Characteristics

3.1 Test Setup

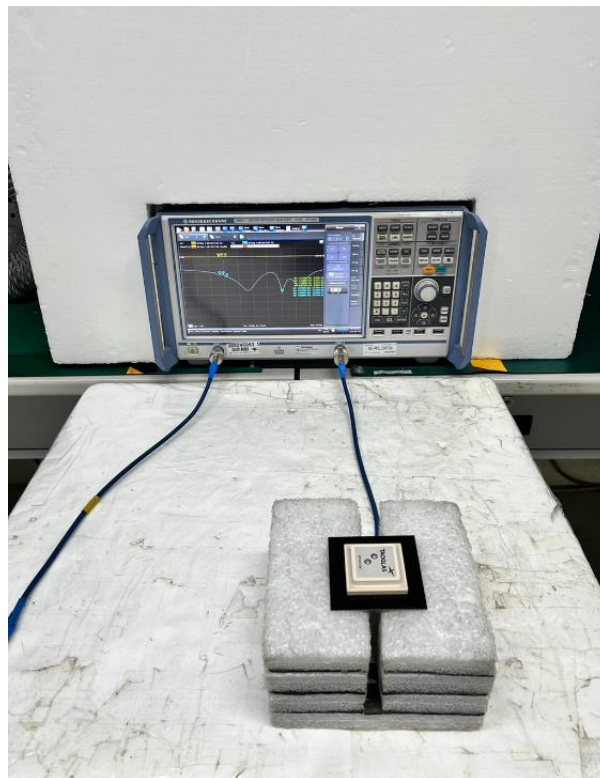
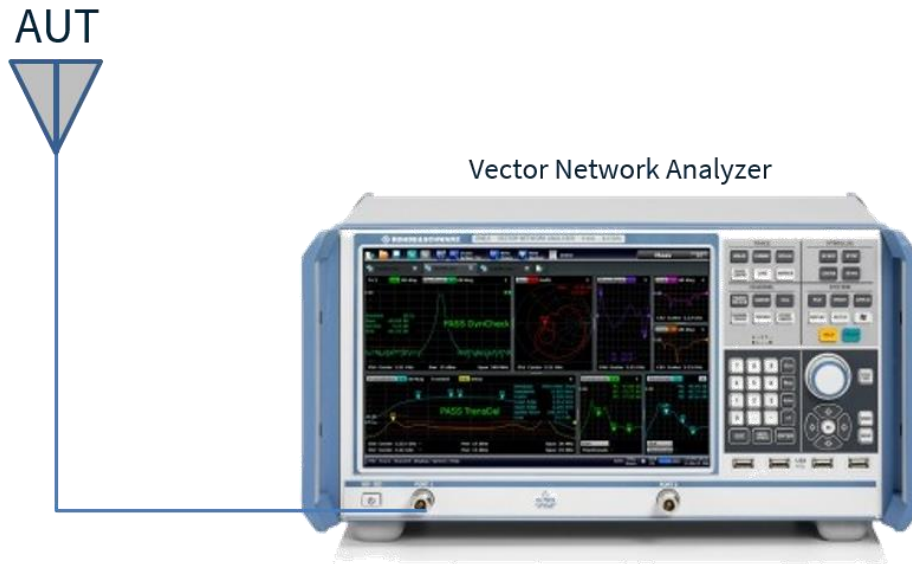

VNA Test Setup – Tested on 70x70mm Evaluation Board.

3.2 Return Loss

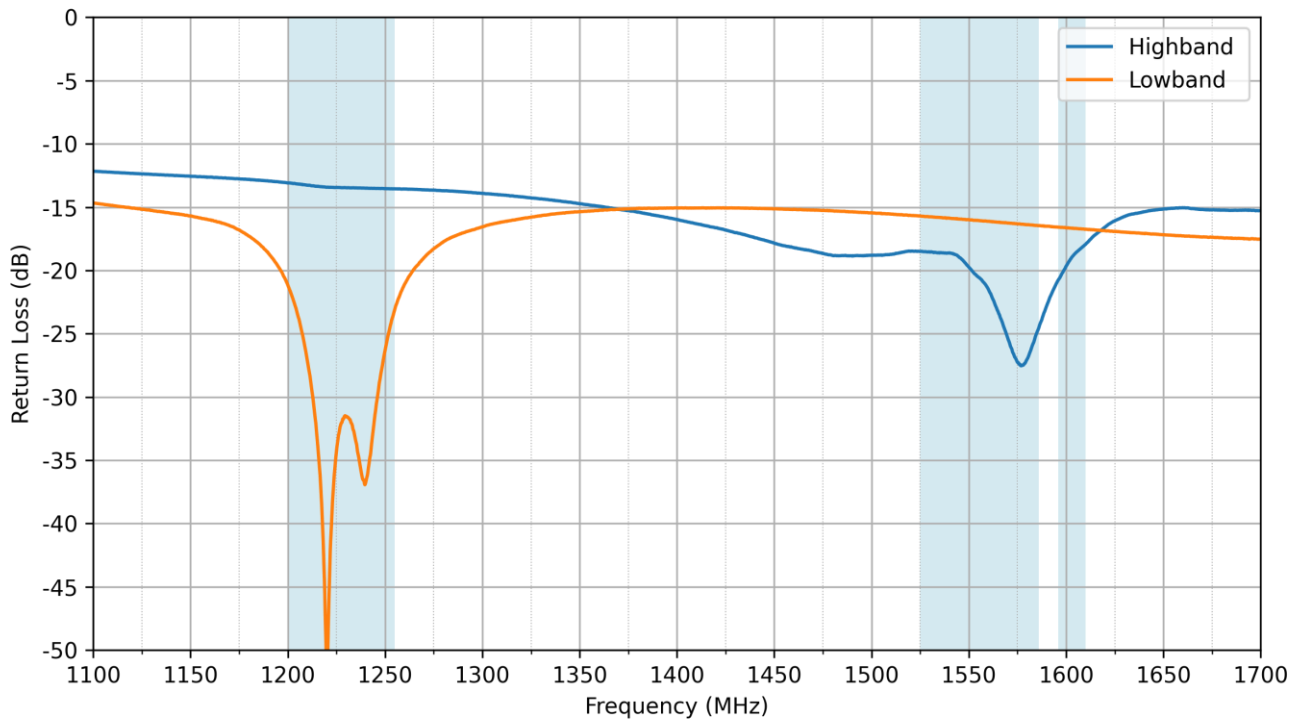

3.3 VSWR

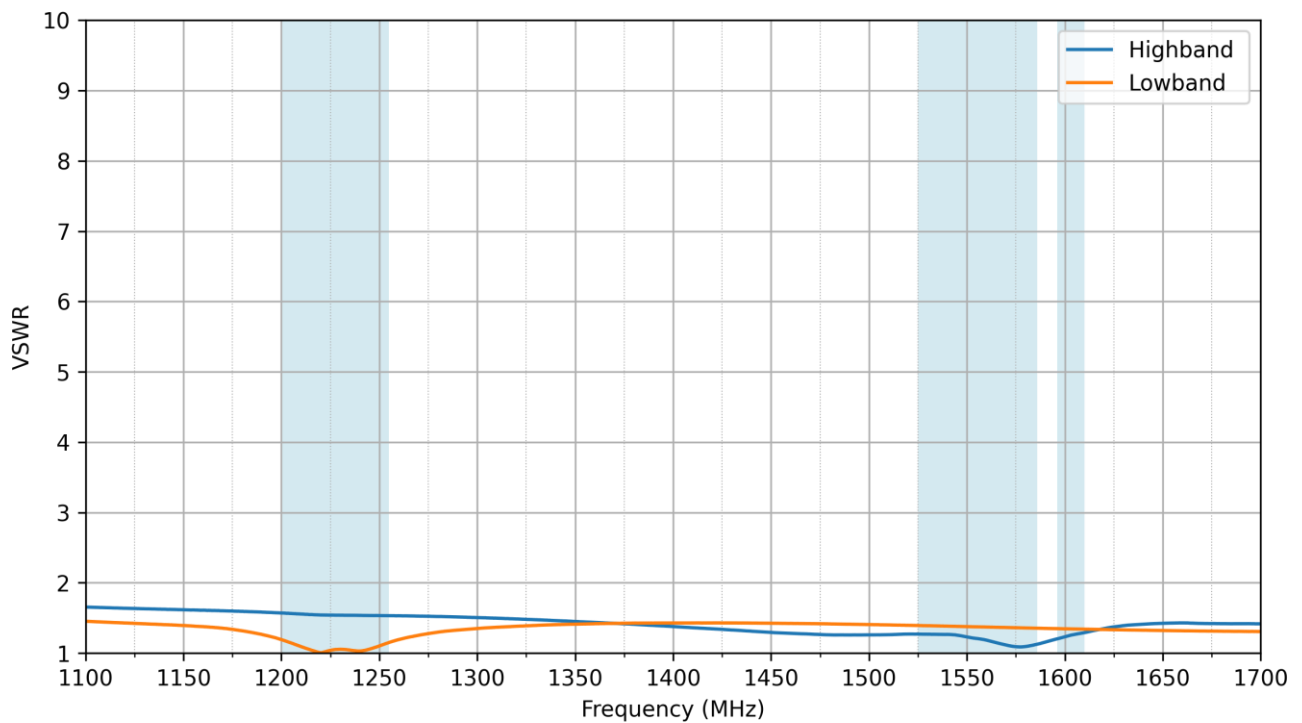

3.4 Efficiency

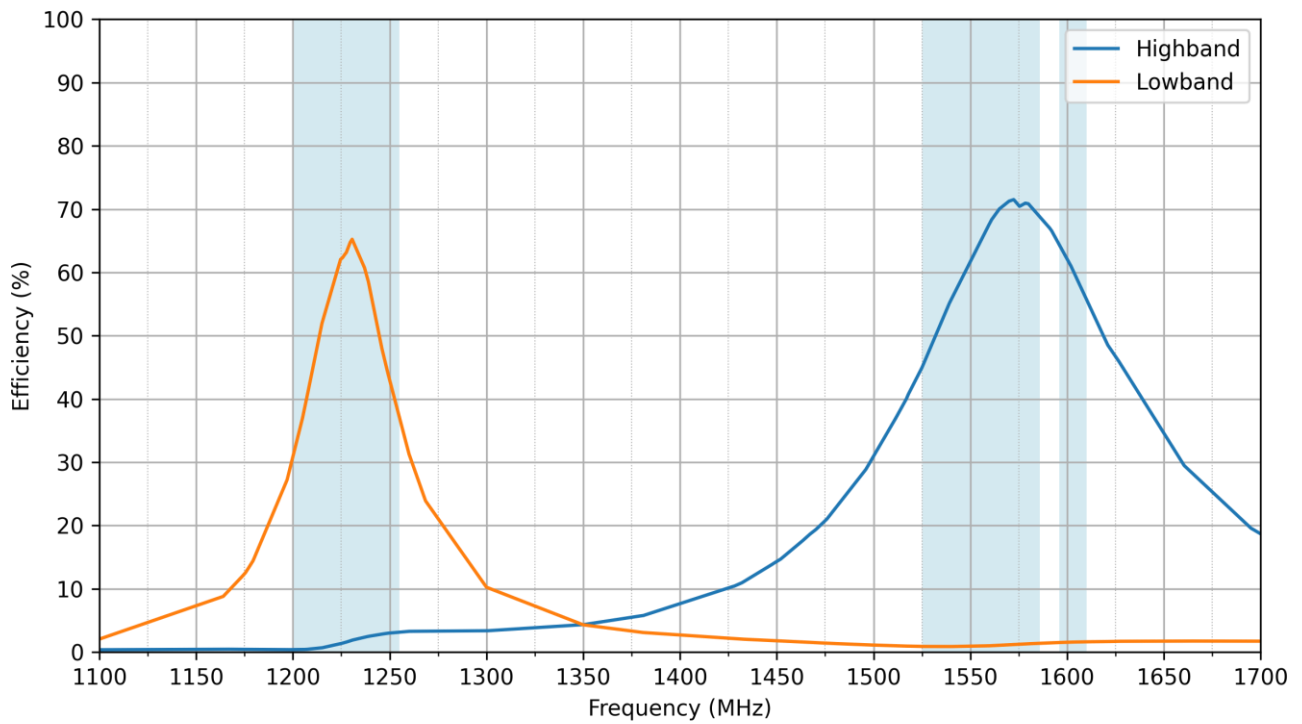

3.5 Average Gain

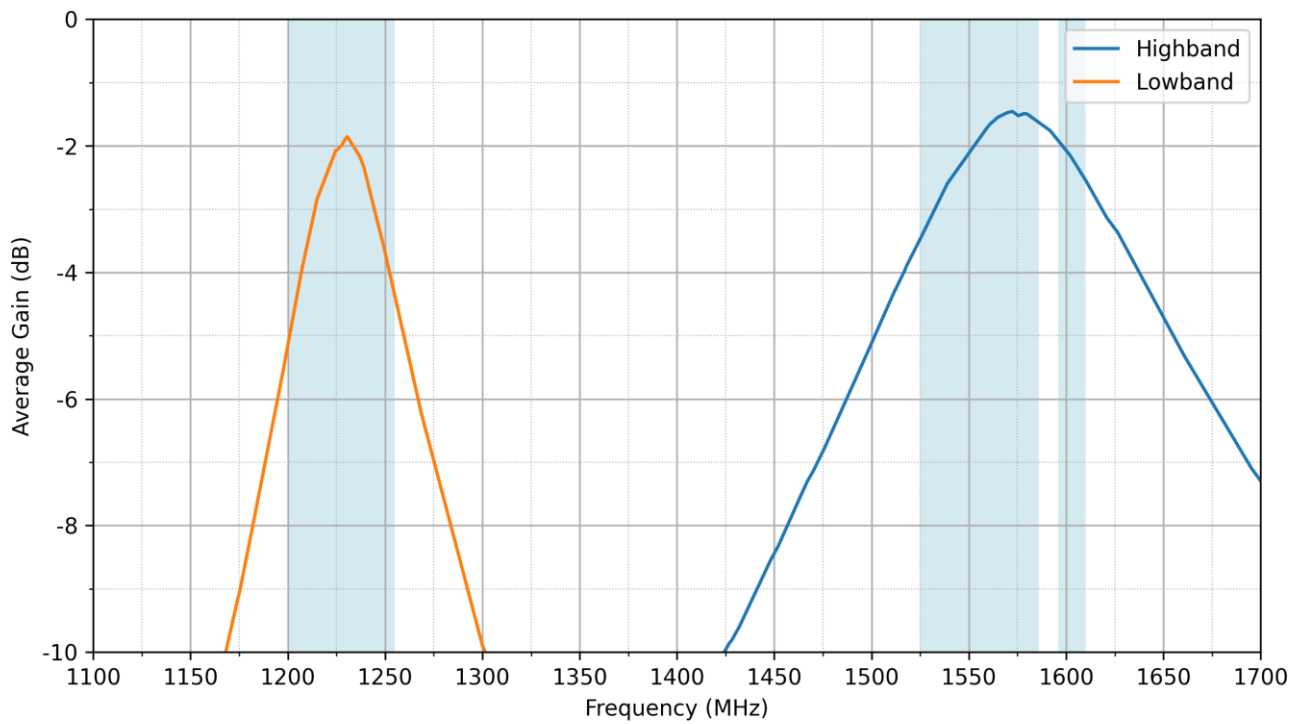

3.6 Peak Gain

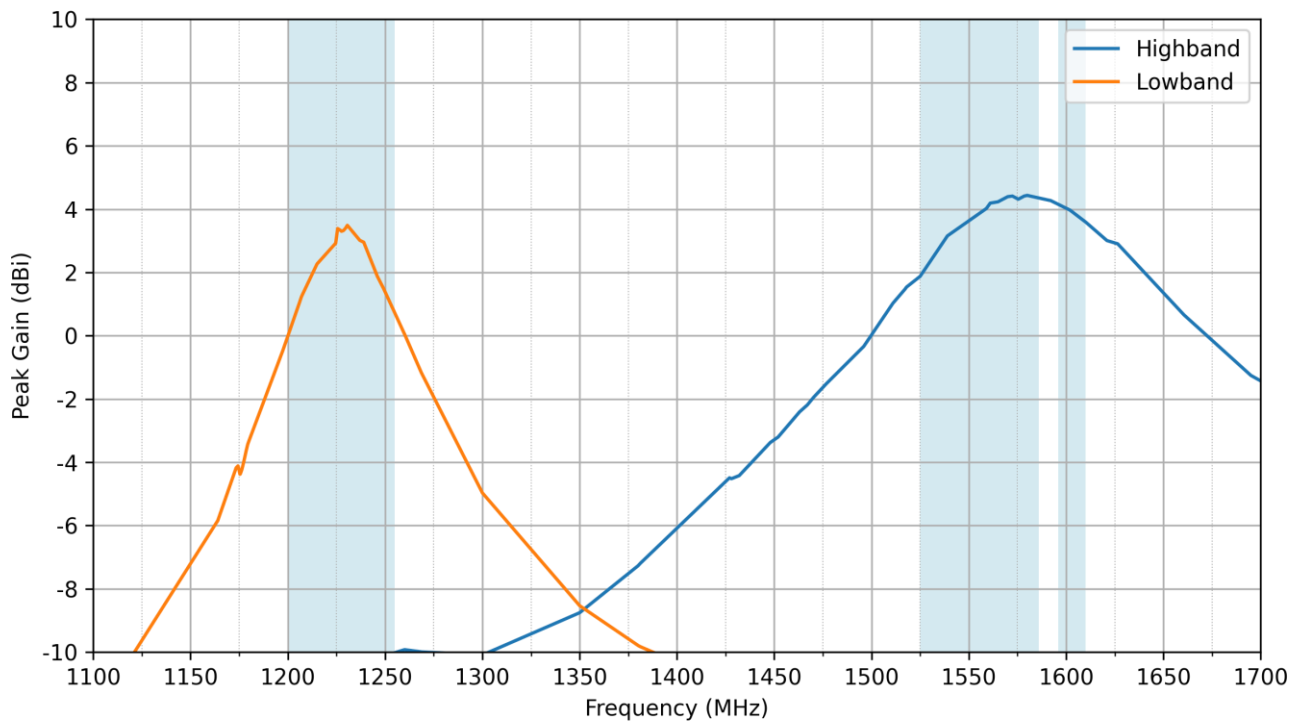

3.7 Axial Ratio

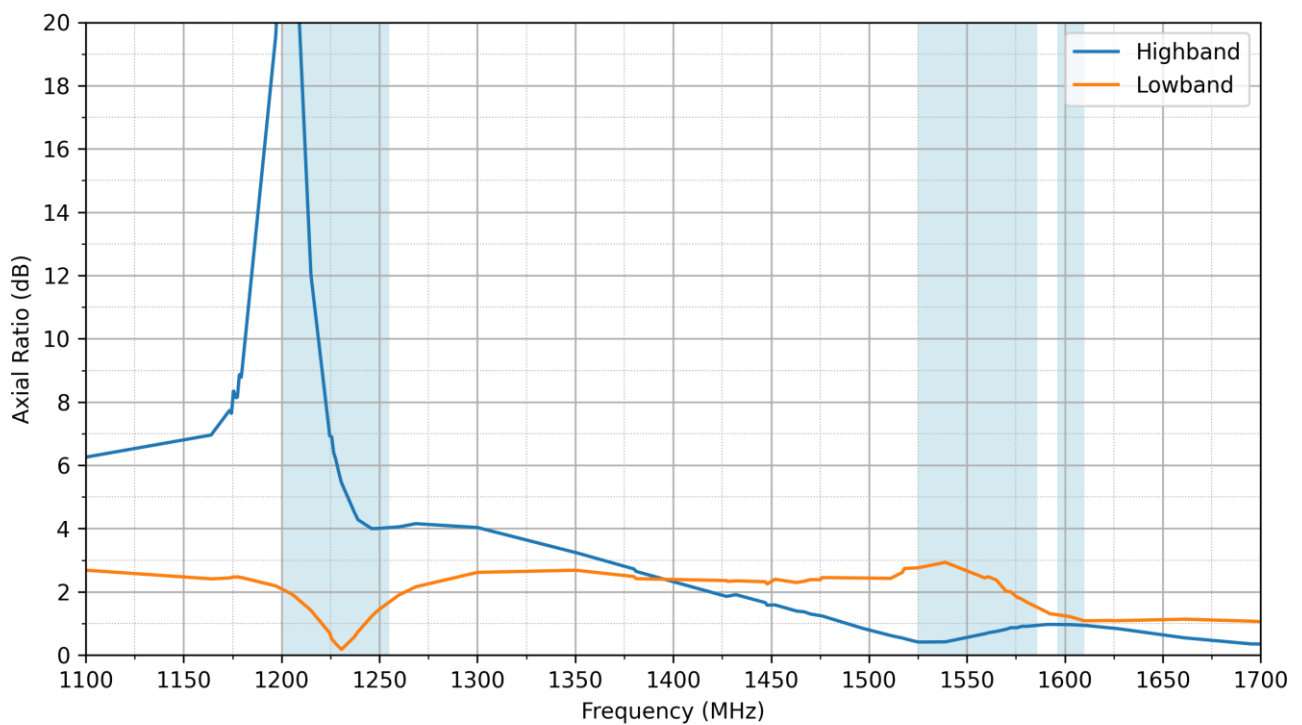

4. Radiation Patterns

4.1 Test Setup

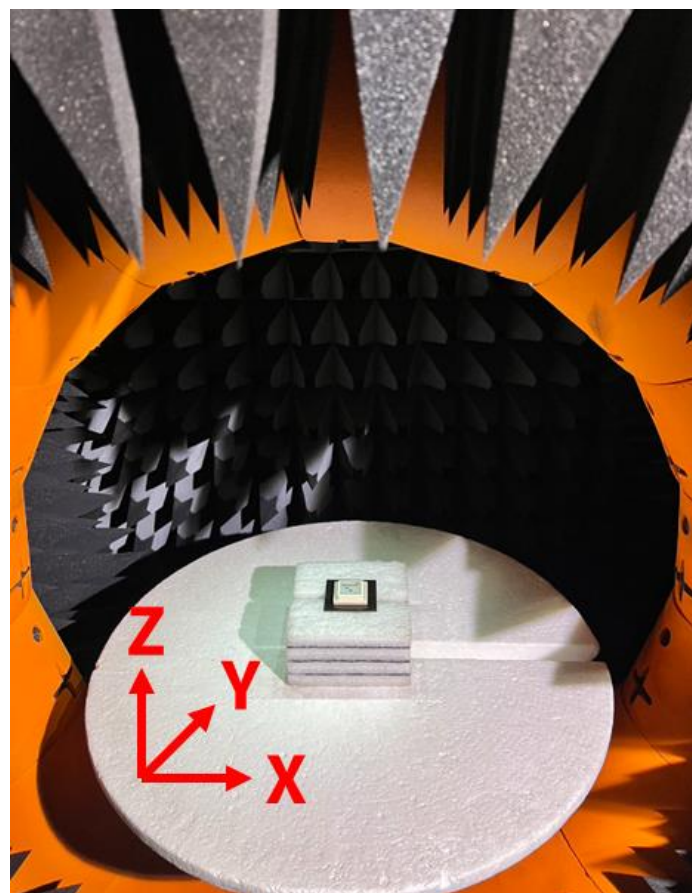
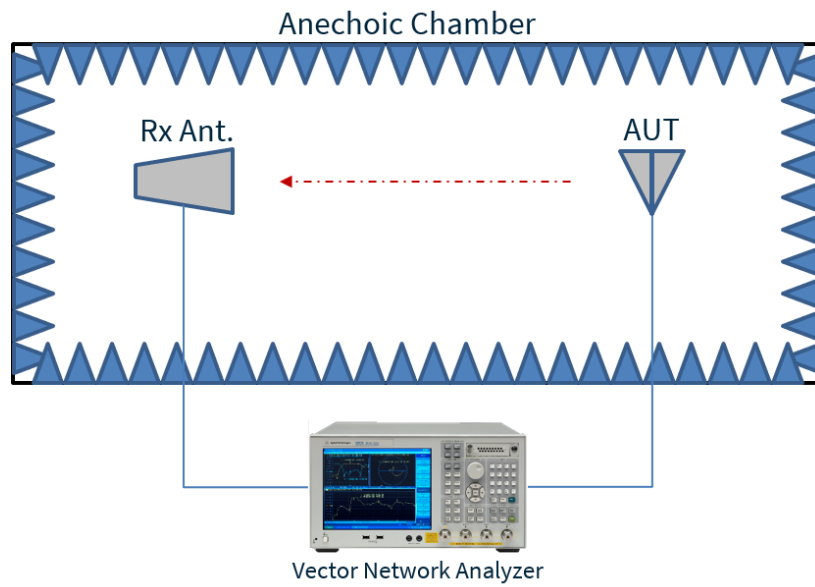

Chamber Test Setup – Tested on 70x70mm Evaluation Board.

4.2 Patterns at 1207 MHz

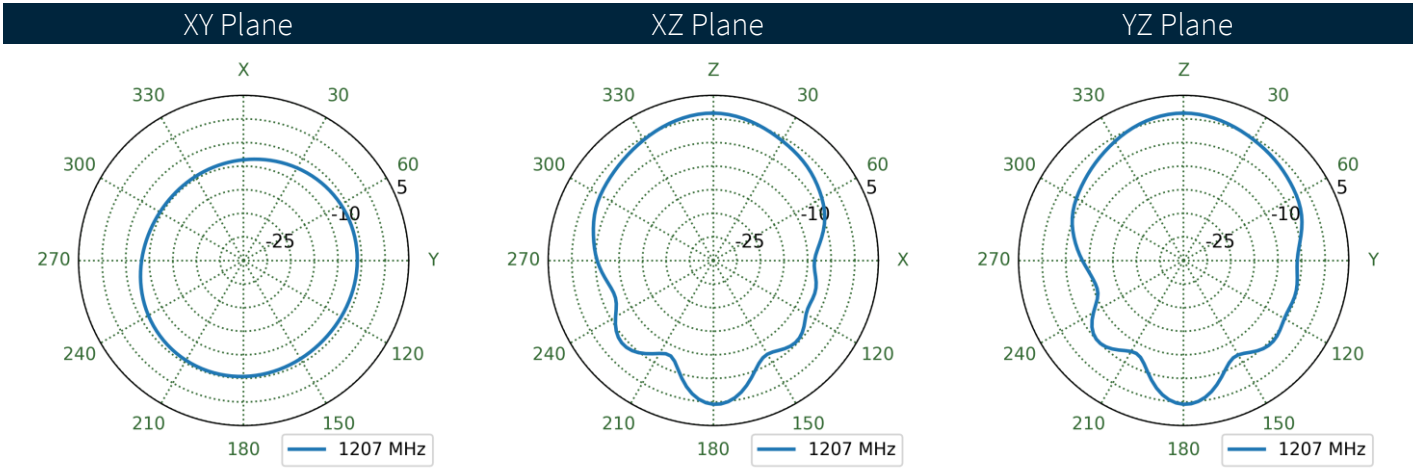
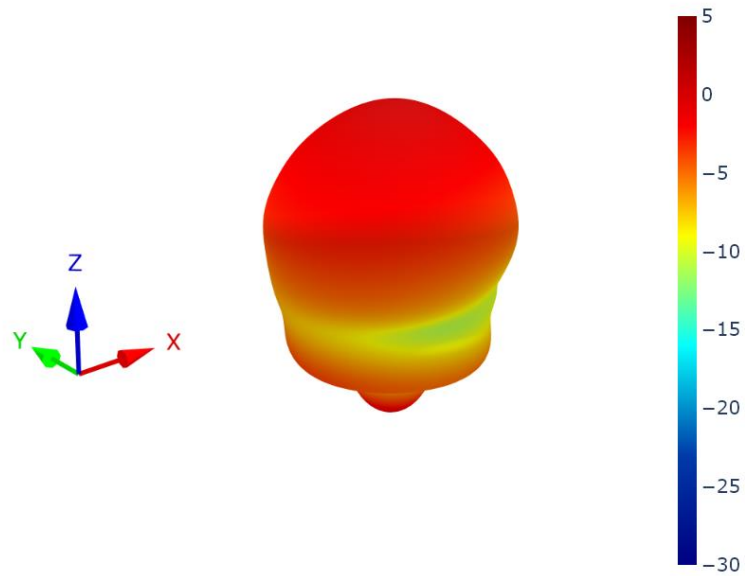

4.3 Patterns at 1227 MHz

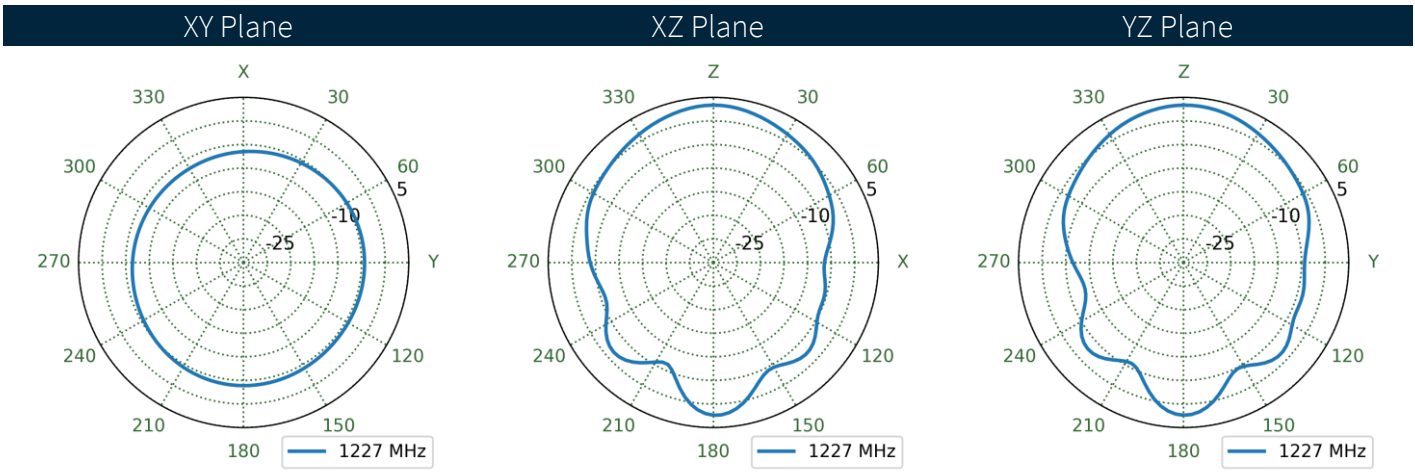
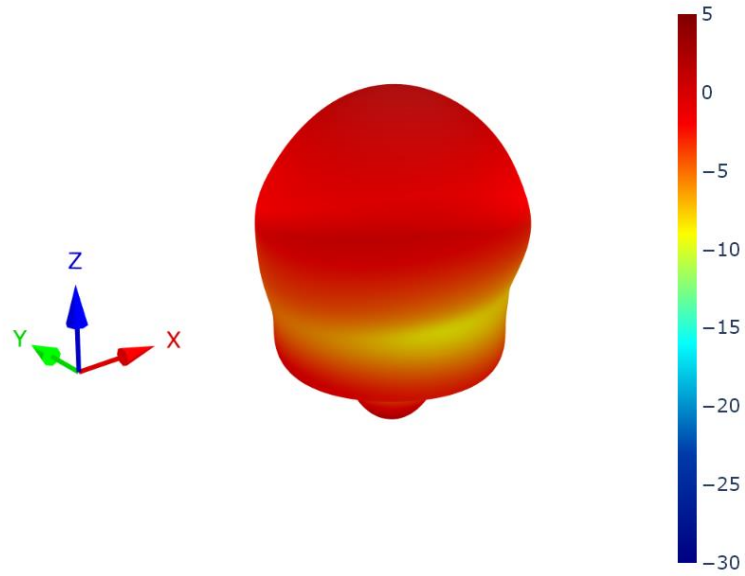

4.4 Patterns at 1249 MHz

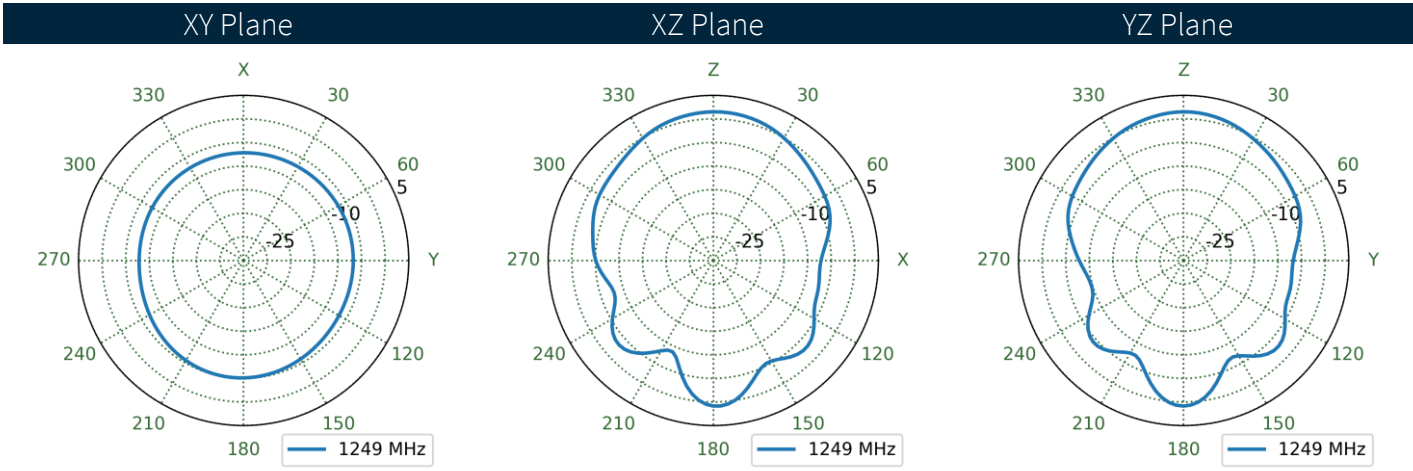
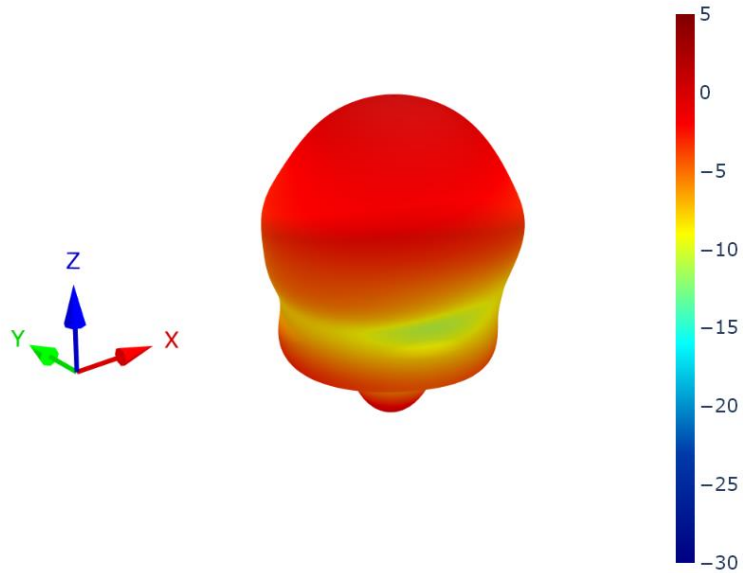

4.5 Patterns at 1525 MHz

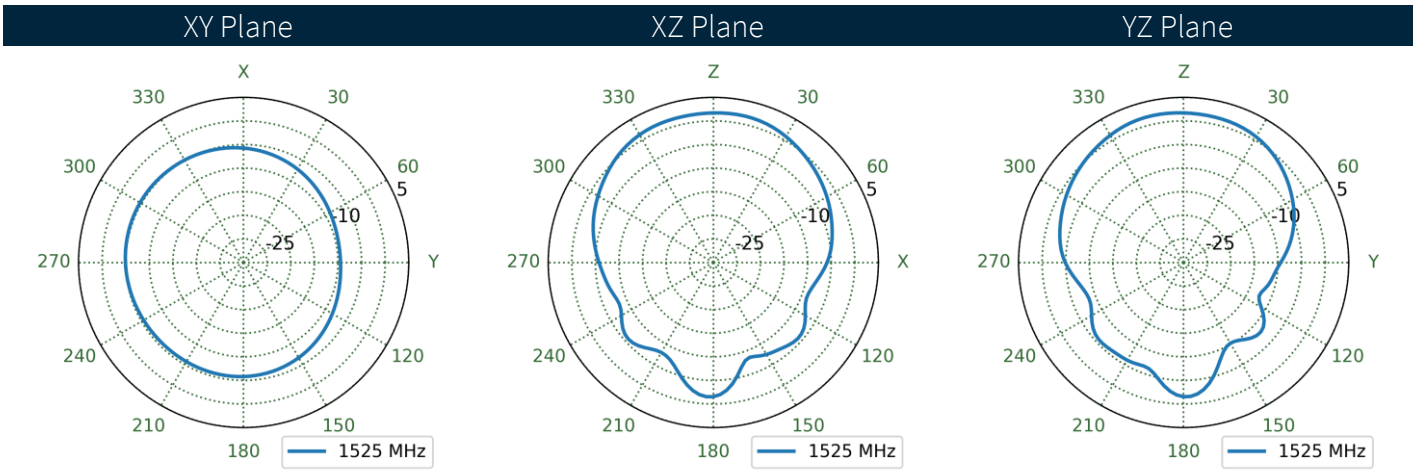
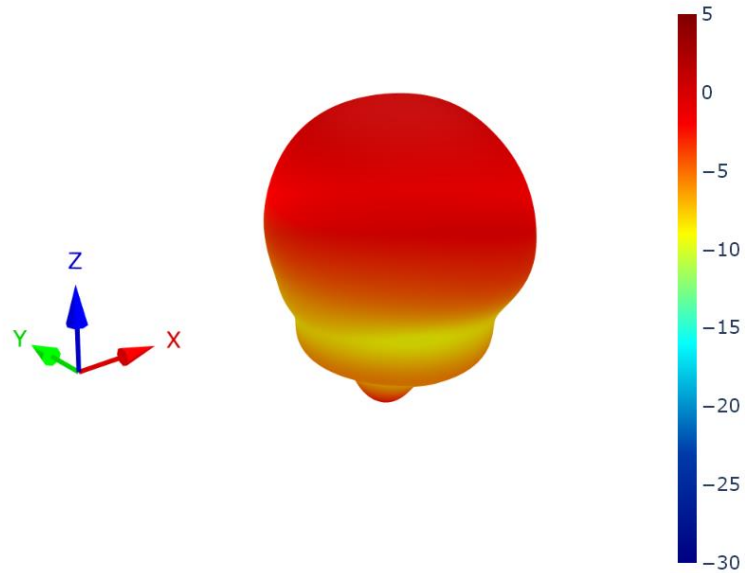

4.6 Patterns at 1539 MHz

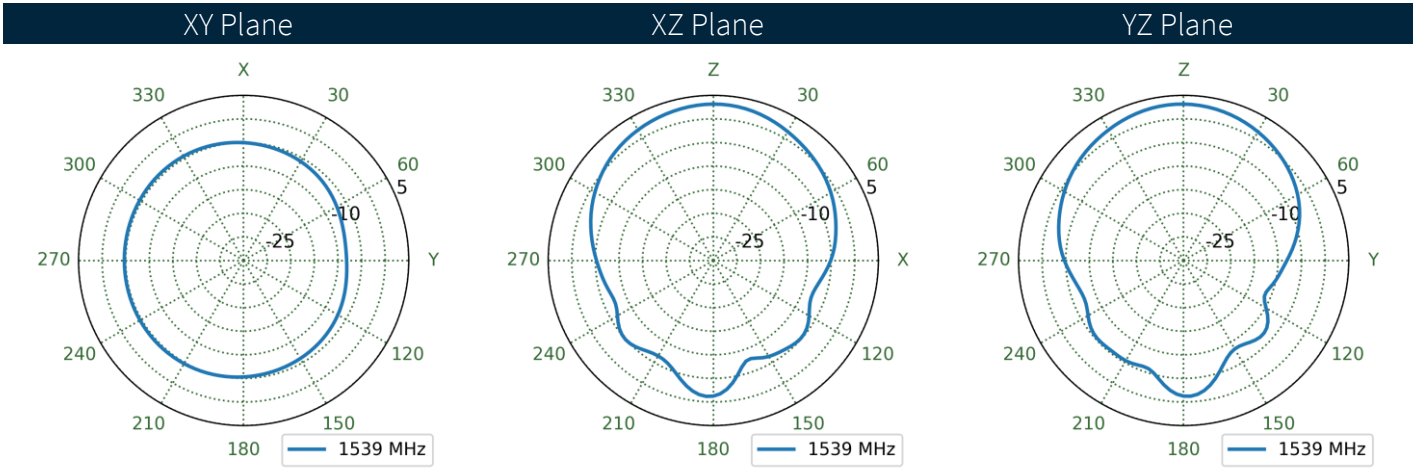
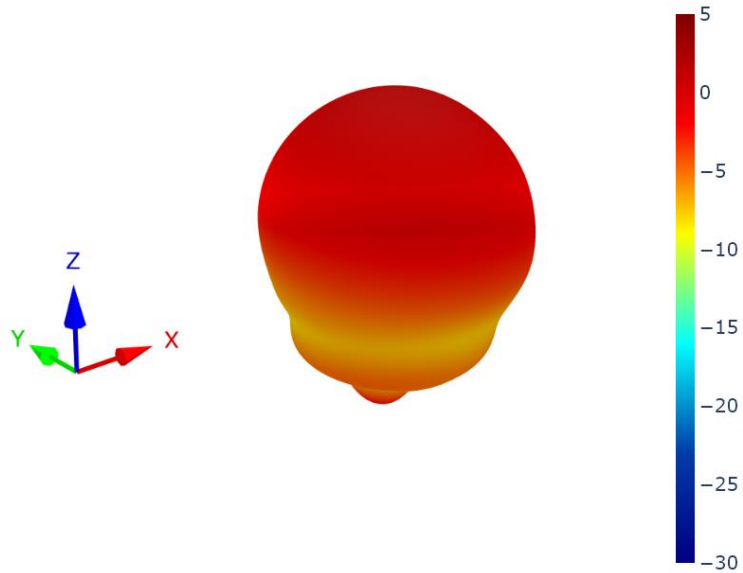

4.7 Patterns at 1559 MHz

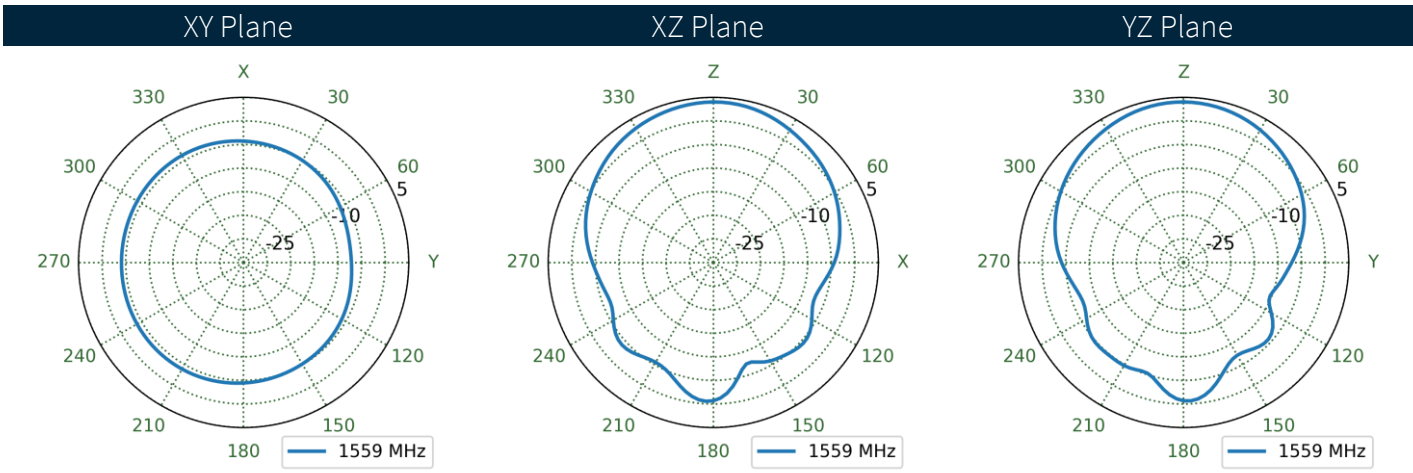
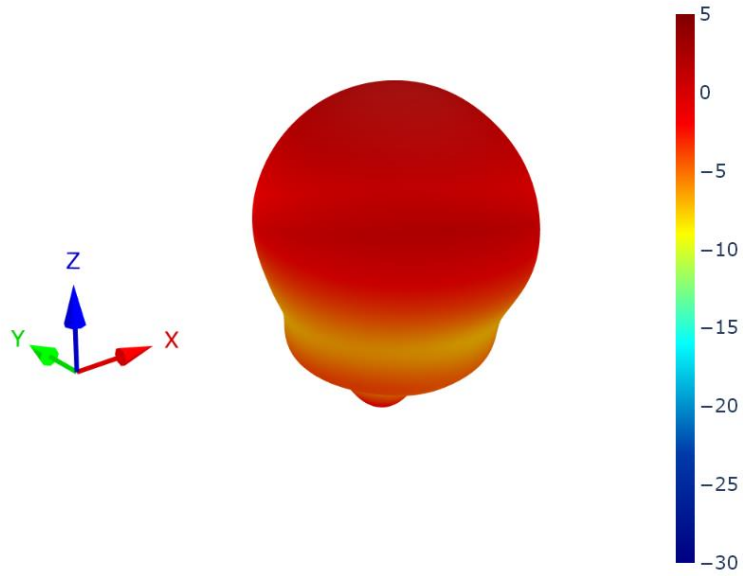

4.8 Patterns at 1561 MHz

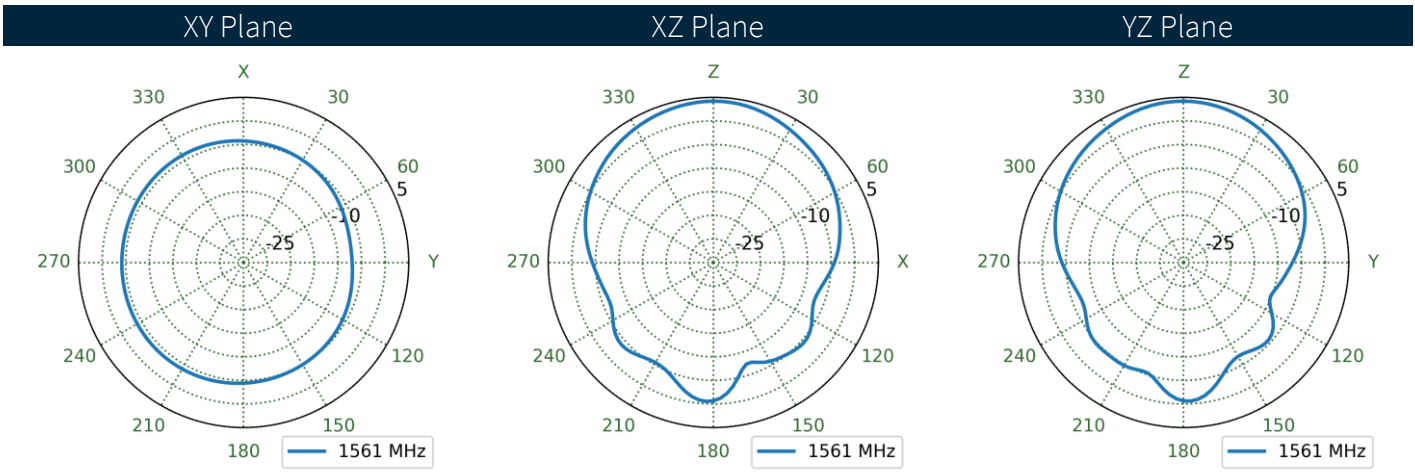
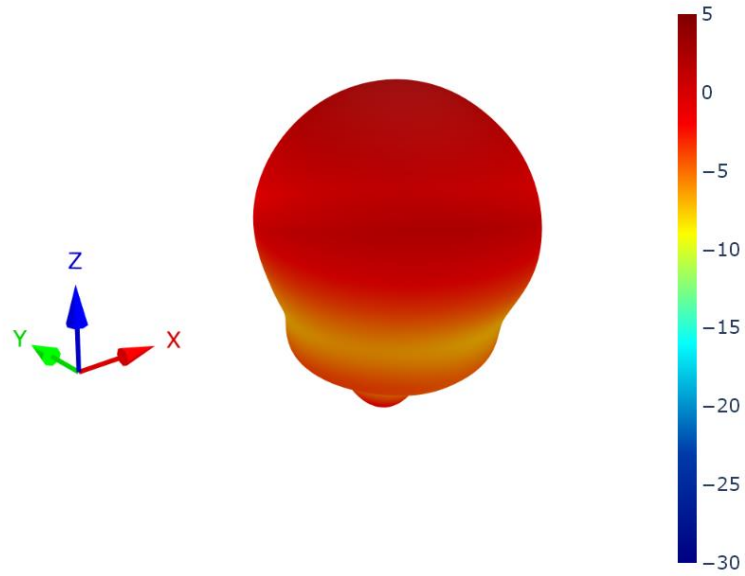

4.9 Patterns at 1575 MHz

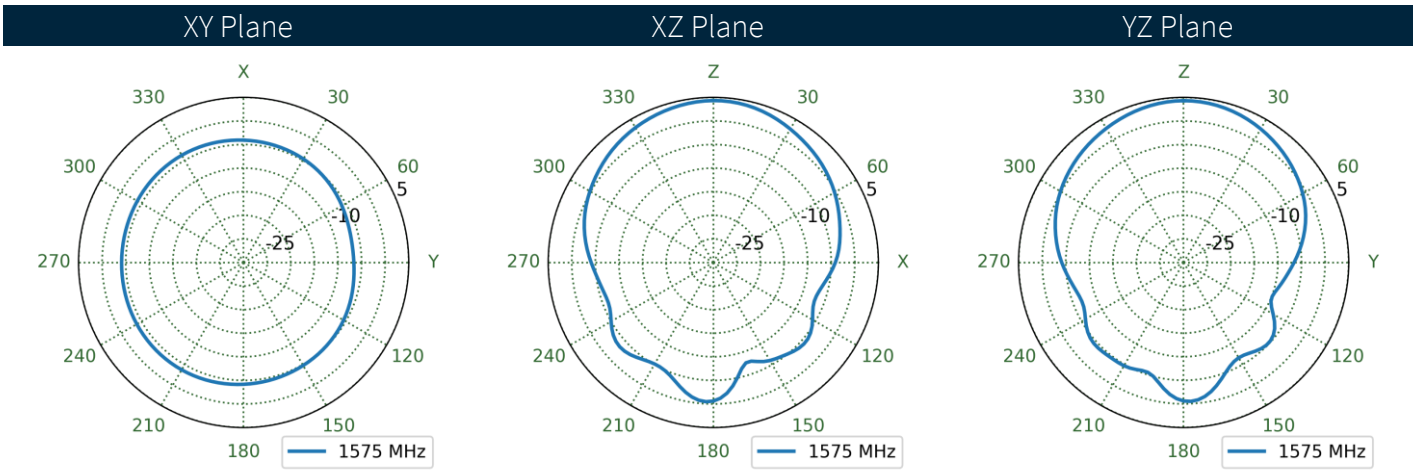
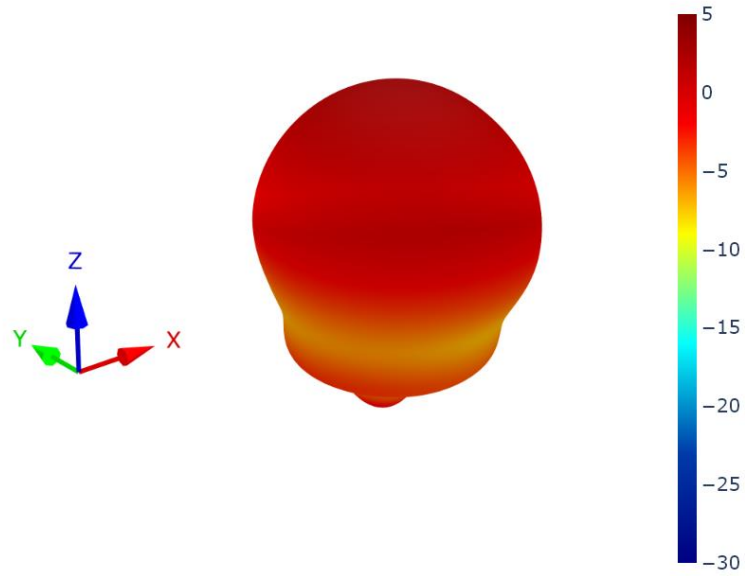

4.10 Patterns at 1602 MHz

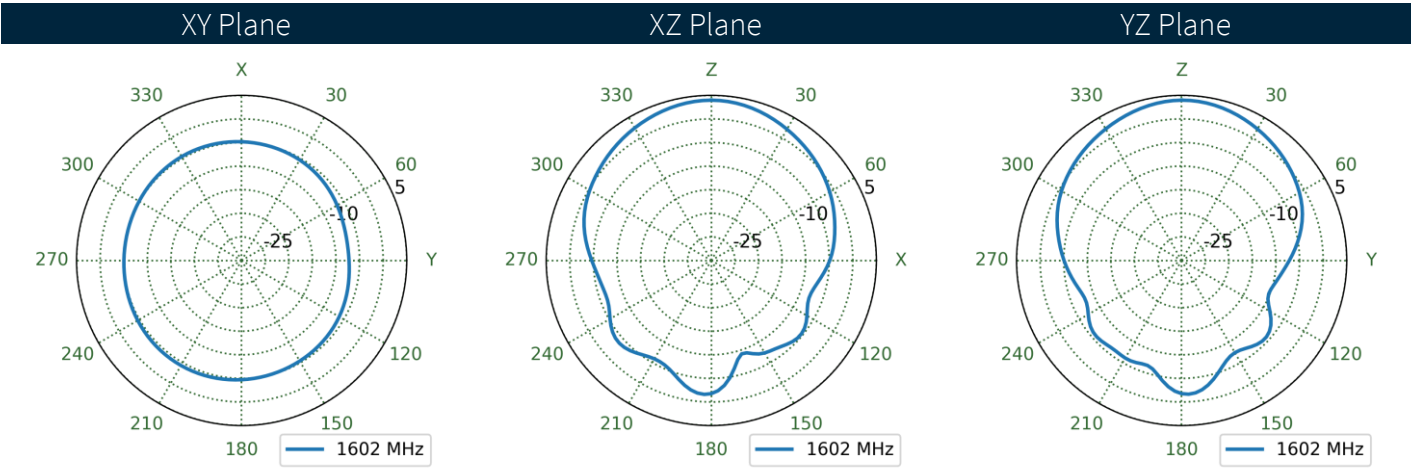
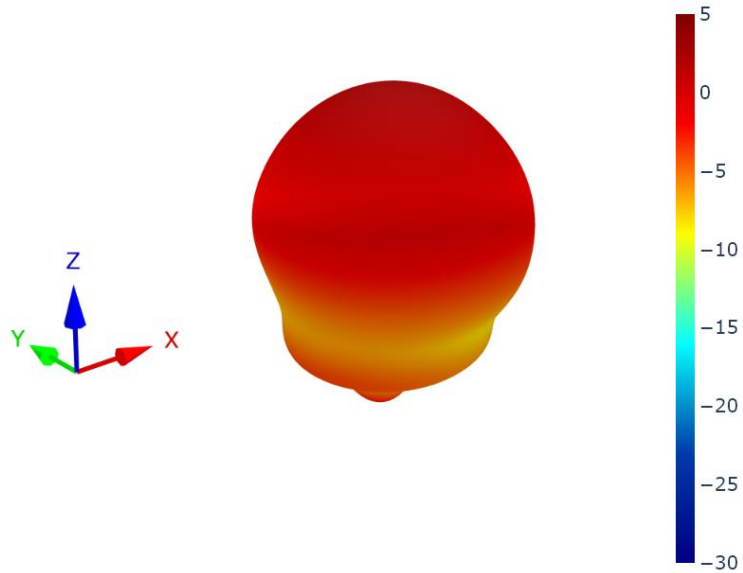

5. LNA Characteristics

5.1 Block Diagram

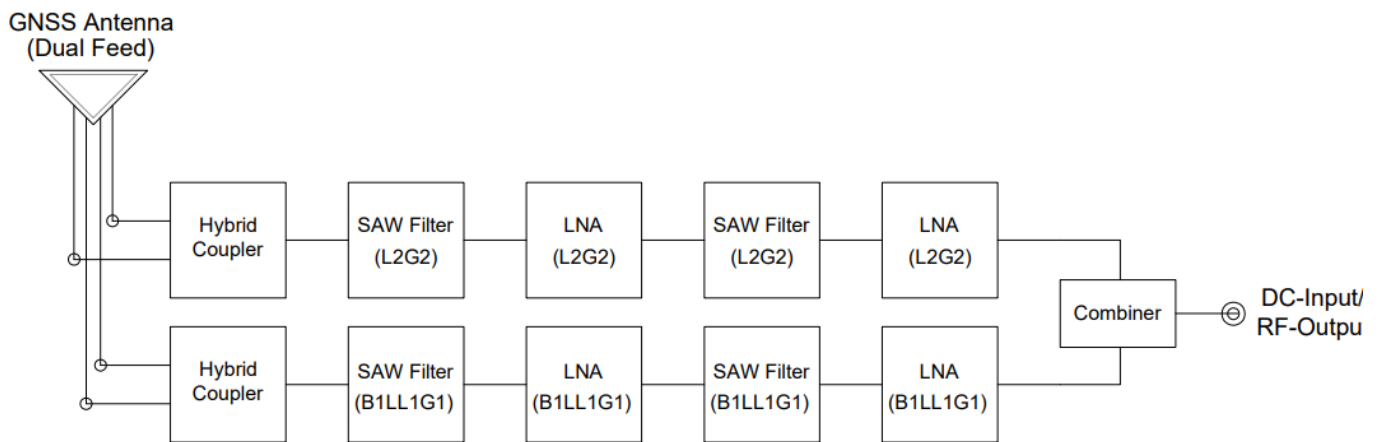

5.2 Noise Figure

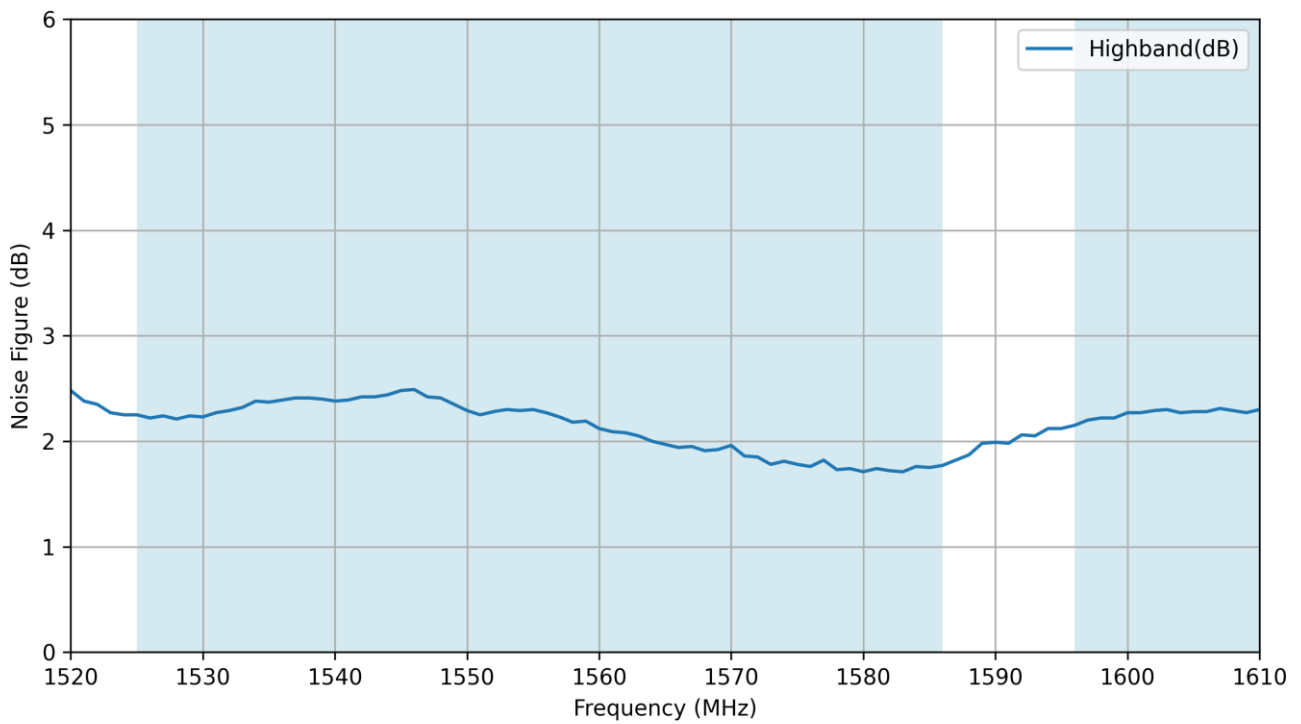
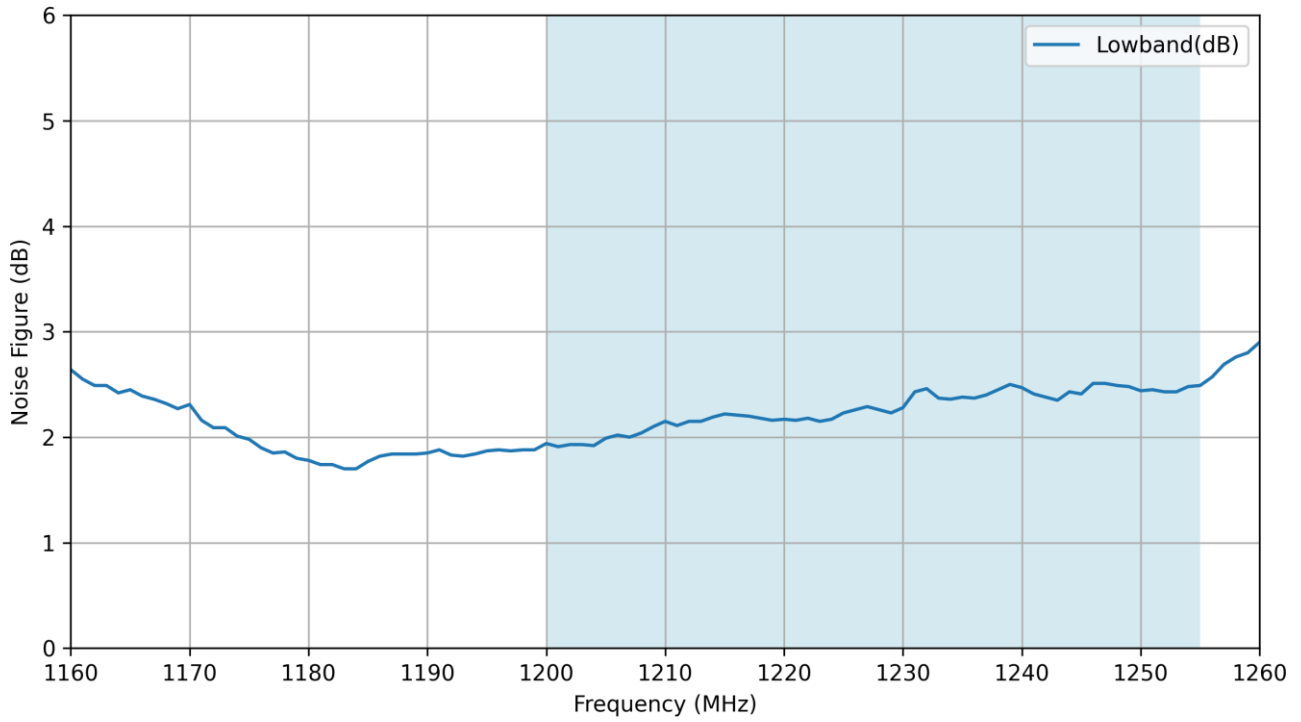

5.3 LNA Gain

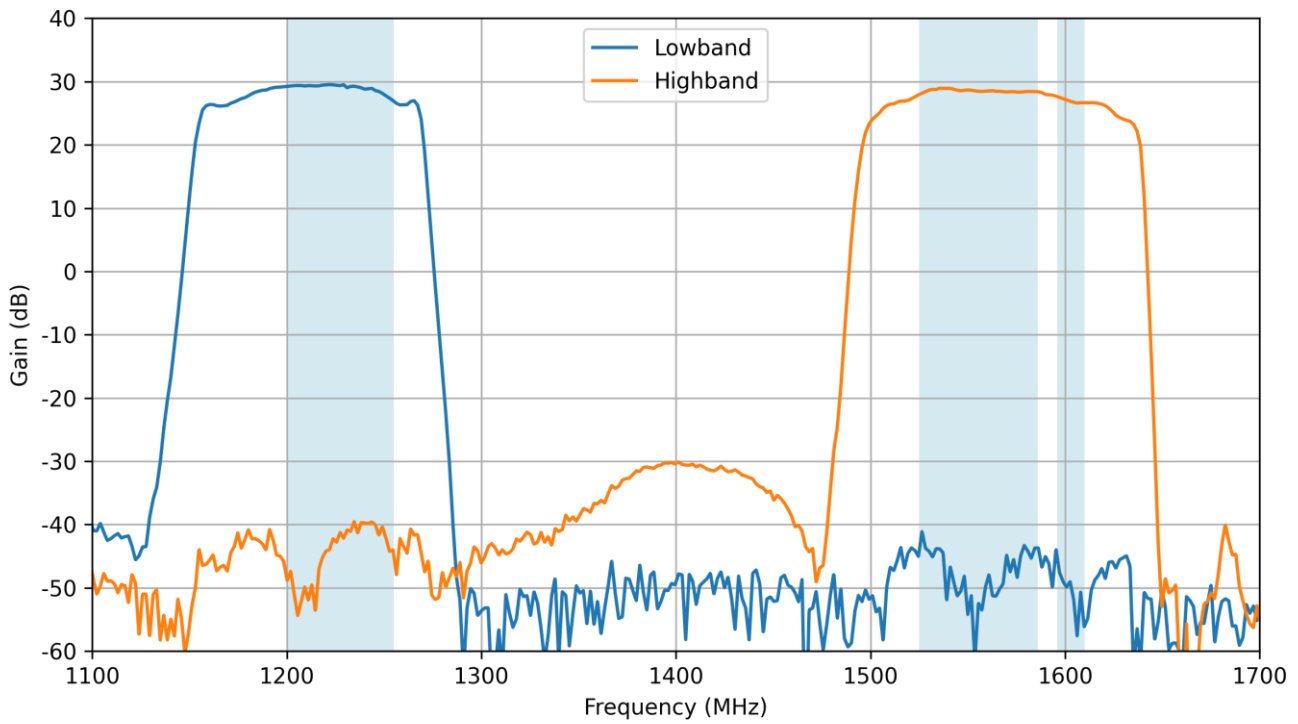

100

5.4 Out-band rejection

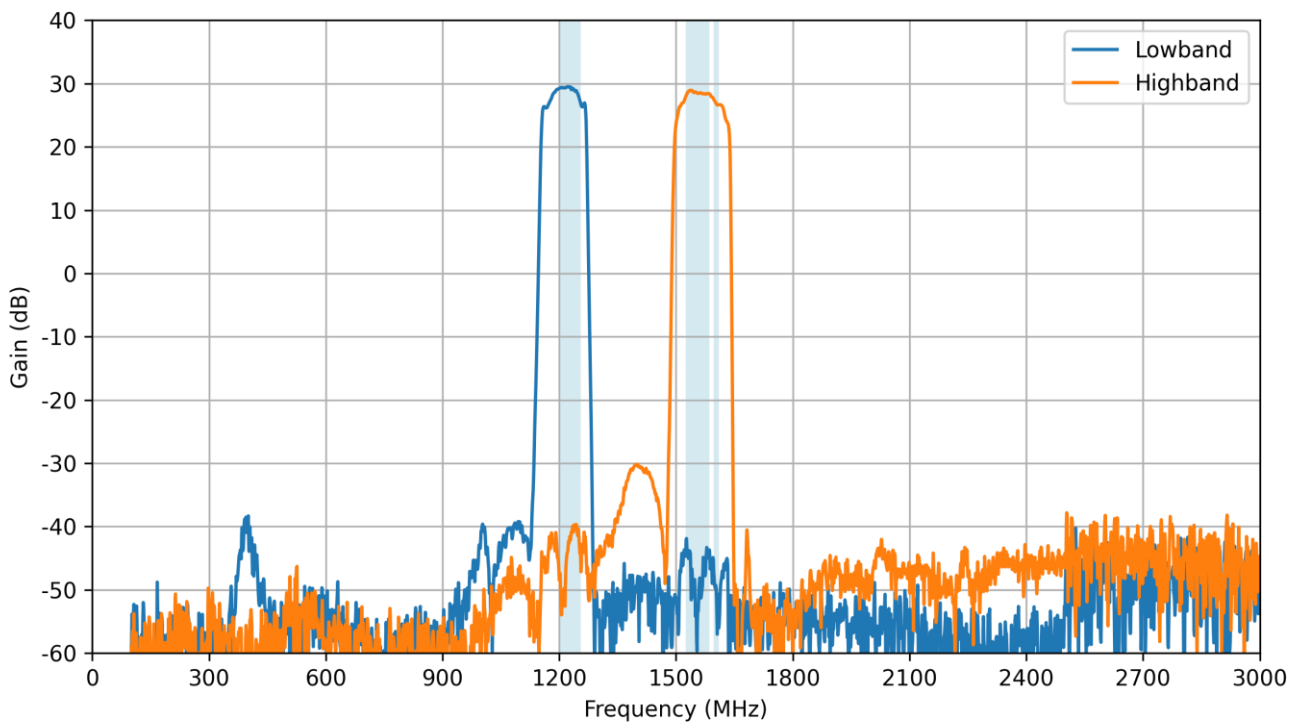

5.5 Group Delay

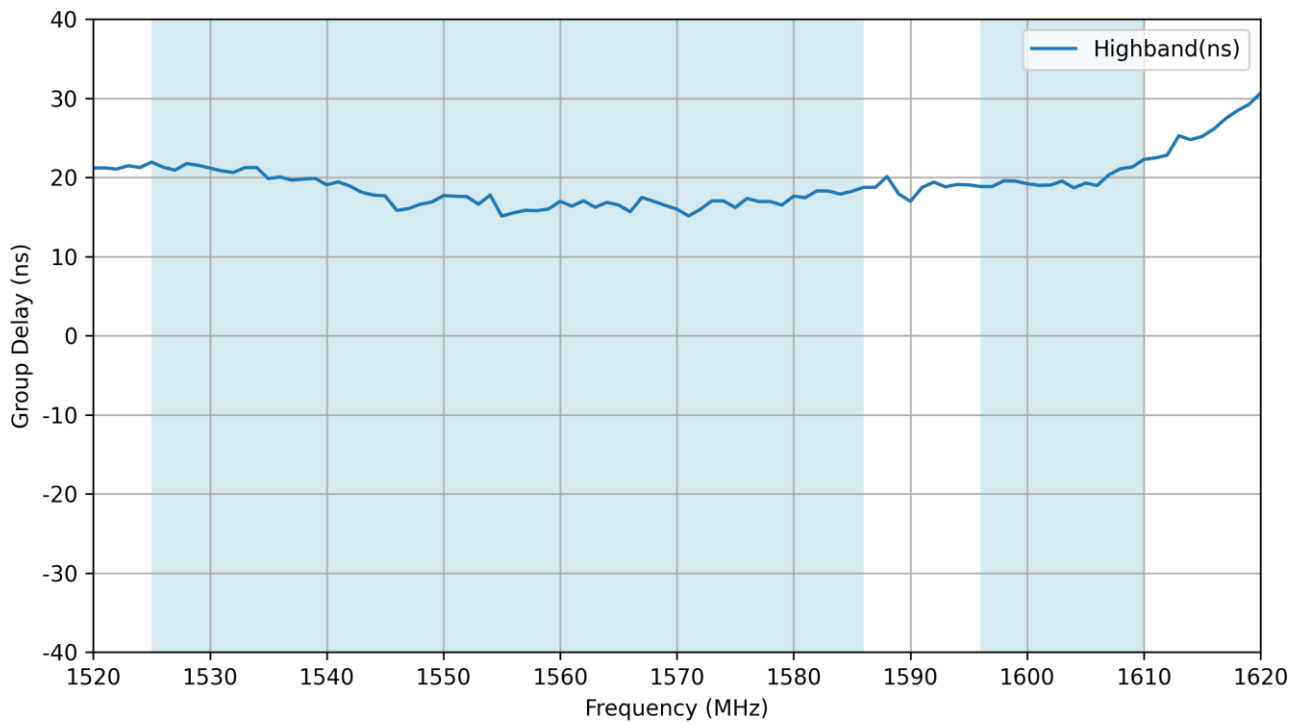
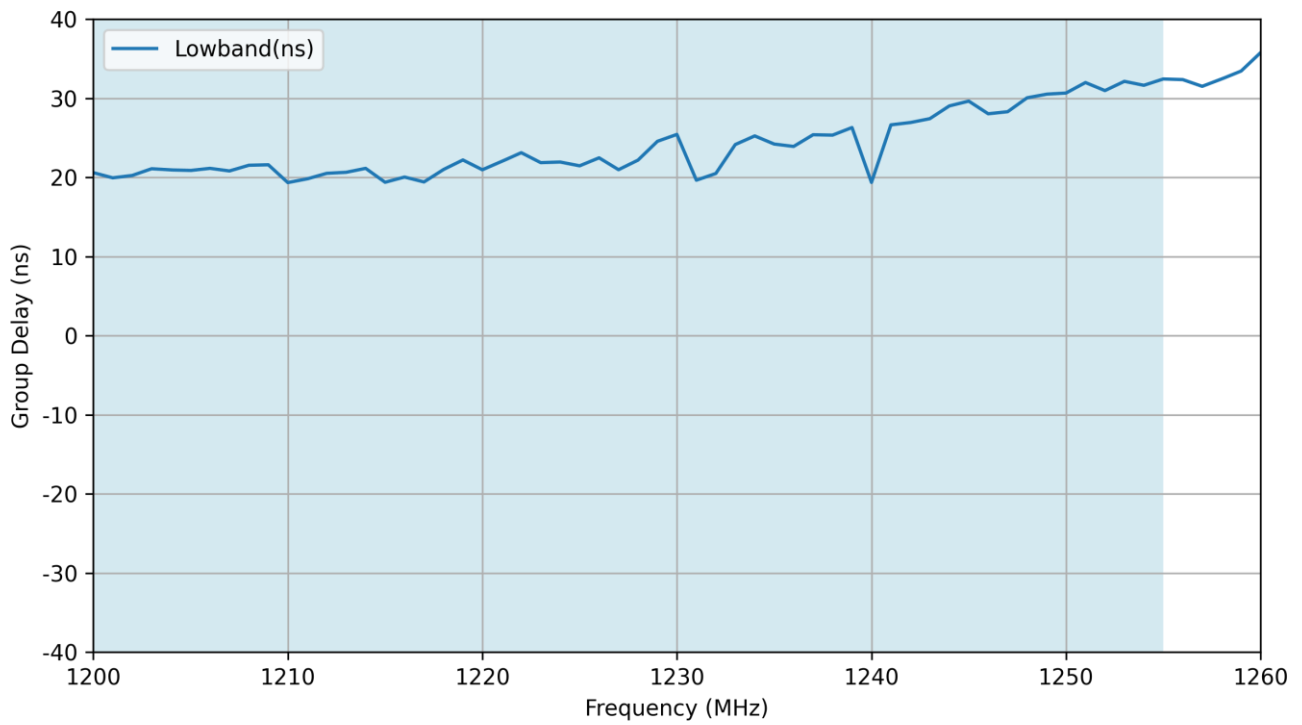

6. Mechanical Drawing

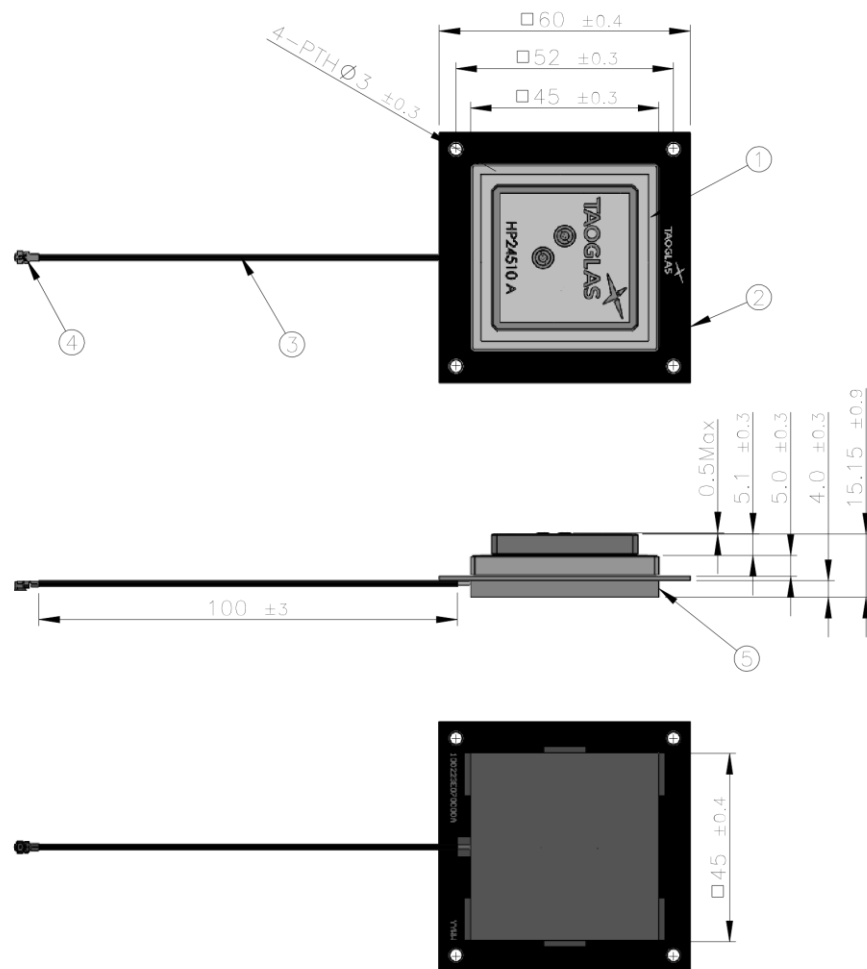

	Name	Material	Finish	QTY
1	Patch	Ceramic	Reddish Brown	1
2	PCB	Composite 1t	Black	1
3	1.37 Coaxial Cable	FBP	Black	1
4	IPEX MHHT	Brass	Au Plated	1
5	Shielding Case	SPTe	Sn Plated	1

7. Packaging

1 PCS AHP24510 per PE Bag



60pcs AHP24510 per Carton
Dimensions: 390x320x290 mm

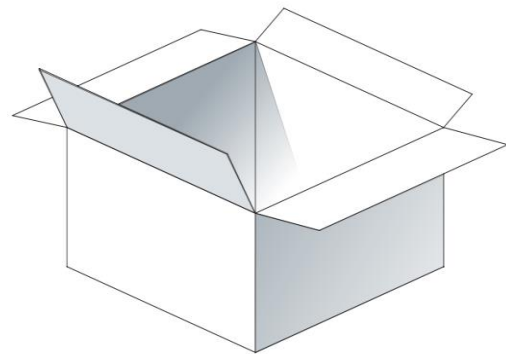



www.taoglas.com

