



TAOGLAS®



Datasheet

Part No:
DMB.GRD.A

Description

Desk Mount Bracket for Guardian Series

Features:

Desk Mount

Dimensions: 175 x 120 x 100mm

With pre-adhered non slip feet

RoHS & REACH Compliant

1.	Introduction	2
2.	Specification	3
3.	Mechanical Drawing	4
4.	Packaging	5

Taoglas makes no warranties based on the accuracy or completeness of the contents of this document and reserves the right to make changes to specifications and product descriptions at any time without notice. Taoglas reserves all rights to this document and the information contained herein. Reproduction, use or disclosure to third parties without express permission is strictly prohibited.



1. Introduction



The Taoglas DMB.GRD.A has been designed for the Guardian Series of Taoglas products, it has been designed to utilize a desk mounting method for the Guardian Series which are excellent for indoor applications like home Wi-Fi or Office connectivity.

Configurations are available to suit your mounting requirements:

- Desk Mount

Contact your regional Taoglas customer support team for further information. This bracket is fully compatible with all variants(custom or standard) of our Guardian MA9XX Adhesive mount Series. See below standard parts:

Part Numbers
MA910.A.CG.001
MA912.A.BI.001
MA990.A.001
MA964.A.CGHM.003.je
MA963.A.BIVW.002
MA952.A.LBIVW.001
MA931.A.LBICGH.001
MA961.A.BICG.002
MA961.W.A.BICG.002
MA931.A.LBICGH.008
MA950.A.LBICG.005
MA995.A.001
MA910.W.A.CG.001
MA912.W.A.BI.001
MA931.W.A.LBICGH.001
MA950.W.A.LBICG.005

2. Specification

Mechanical	
Dimensions	175 x 120 x 100mm
Material	Aluminium
Bracket weight	250g
Environmental	
Operation Temperature	-40°C ~ +85°C
Storage Temperature	-40°C ~ +90°C

3. Mechanical Drawing

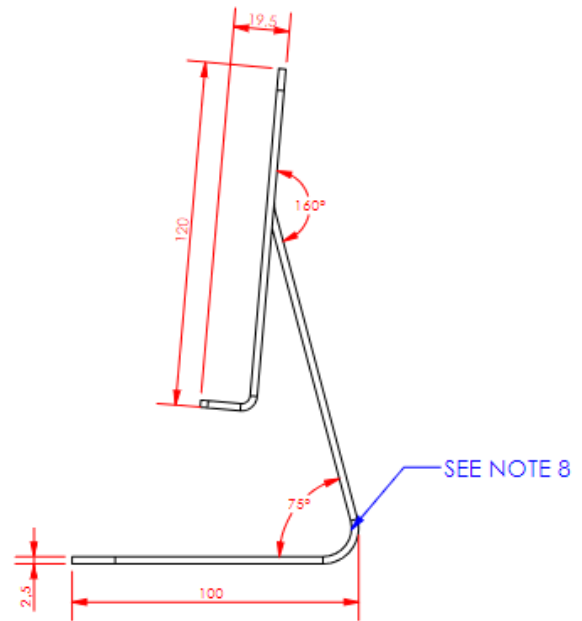
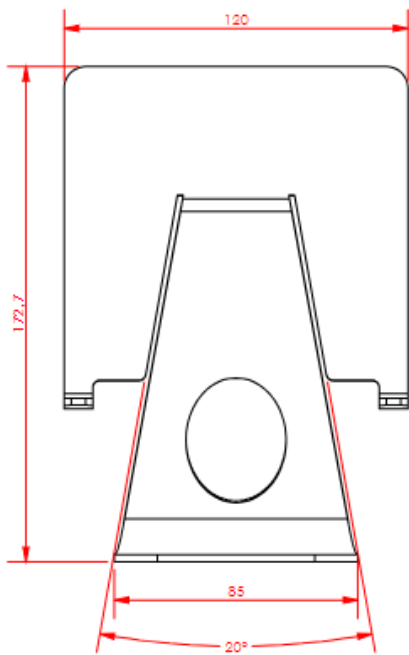

4. Packaging

Changelog for the datasheet

SPE-23-8-269– MB.A.MX1

Revision: A (Initial Release)

Date: 2023-09-14

Changes: Initial Release

Changes Made by: Cesar Sousa

Previous Revisions



www.taoglas.com

