

# Quad FAKRA Code B White Connector

Quad FAKRA – Code B for RG-174/RG-316/1.5DS cables

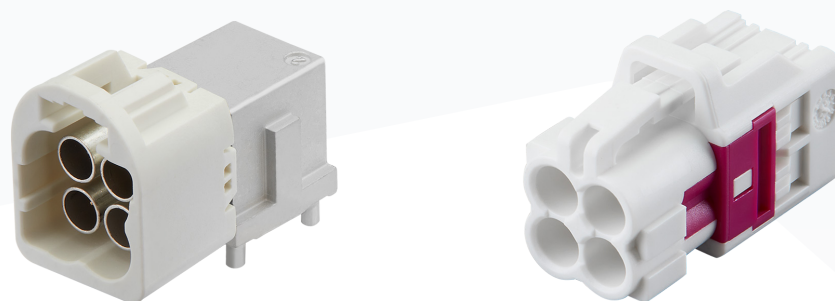

## Product description

Taoglas is a leading provider of advanced technology for a smarter world. Our solutions include advanced components and technologies and help OEMs, enterprises, and communities to resolve the complexities of bringing digital transformation solutions to market quickly and cost effectively. Focused on best-in-class, high-performance antenna and RF design with advanced positioning, imaging, audio and artificial intelligence technologies, Taoglas understands the importance of high-performance connections.

Taoglas Quad FAKRA connectors utilize a metal SMB connector embedded within a plastic enclosure that is colour coded and keyed for ease of identification and assembly. They have been designed with a swivel style housing for ease of installation. They are designed for high-volume production, automated harness assembly and provide superior performance. They are manufactured with the highest precision and are thoroughly tested to meet USCAR-2 and USCAR-17 standards. All Taoglas connectors are RoHS & REACH compliant.

The White Code B connector is typically used for AM/FM connections and is available in both Jack and Plug and for multiple cable diameters.

## Features

- Optimized for automated manufacturing
- Full Series of colours available
- RF performance up to 6GHz
- Primary and Secondary Locks
- Tulip contact/ anti-stubbing
- Housing inner ring / anti-scooping
- Fully compliant to USCAR requirements

## Specifications

Electrical		
Impedance		50Ω Nominal
Operating Frequency		0 ~ 9000MHz
Mechanical		
Insertion Force		≤45N
Withdraw Force		≥5N
Latch force		≥110N
Mating cycle		≥25
Terminal Tensile Strength		≥30N
Storage and Operational Temperature Range		-40°C - 105°C
Cable Range		
Suitable Cables		RG-174, RG-316, 1.5DS
Conductor Range		0.61mm



# Quad FAKRA Code B - White

## Mechanical Drawings

**FKQRFBF** - Code B Female Jack for RG-174/RG-316/1.5DS

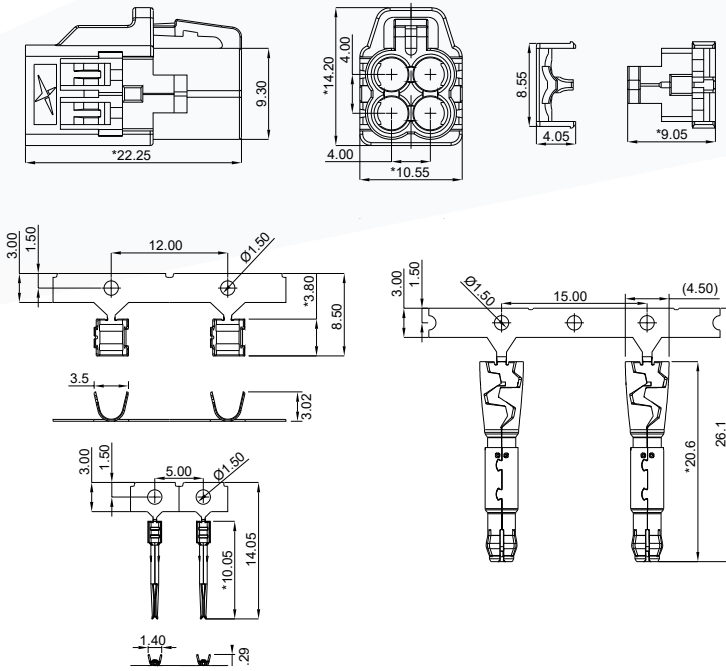

**FKQRMBCB** - Code B Male Plug for RG-174/RG-316/1.5DS

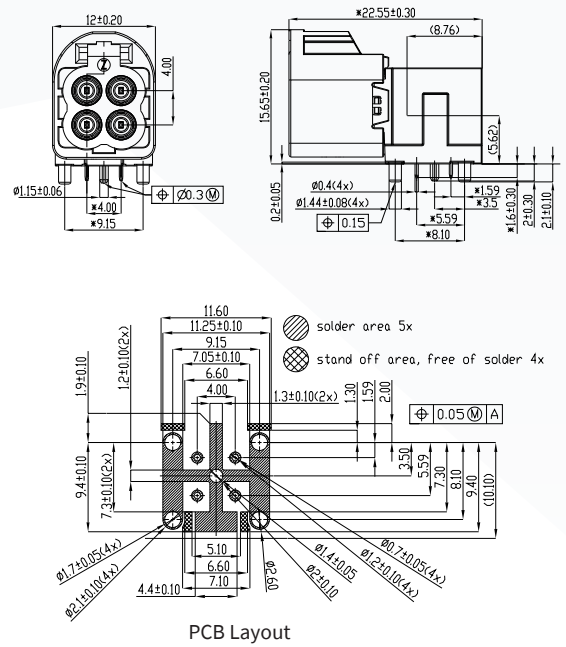

Taoglas makes no warranties based on the accuracy or completeness of the contents of this document and reserves the right to make changes to specifications and product descriptions at any time without notice. Taoglas reserves all rights to this document and the information contained herein. Reproduction, use or disclosure to third parties without express permission is strictly prohibited.

