



# TAOGLAS®



# Datasheet

**Part No:**  
FXP055.A.07.C.001

## Description

GNSS and Wi-Fi Flex PCB Antenna 2 feeds 100mm 1.37 cable IPEX MHFI  
With Wi-Fi 6 frequency bands included

## Features:

2-in-1 Flex PCB Antenna  
Covers Extended Wi-Fi Frequencies of 2.4-2.5GHz, 5-7.125GHz  
GNSS frequencies of 1.56-1.61GHz,  
Dimensions: 53\*18\*0.2mm  
Cables: 100mm of  $\varnothing$ 1.37mm  
Connectors: I-PEX MHF® I (U.FL Compatible)  
RoHS & Reach Compliant

<b>1.</b>	<b>Introduction</b>	<b>2</b>
<b>2.</b>	<b>Specification</b>	<b>3</b>
<b>3.</b>	<b>Antenna Characteristics</b>	<b>5</b>
<b>4.</b>	<b>Radiation Patterns</b>	<b>12</b>
<b>5.</b>	<b>Mechanical Drawing</b>	<b>19</b>
<b>6.</b>	<b>Packaging</b>	<b>20</b>
<hr/>		
	Changelog	21

Taoglas makes no warranties based on the accuracy or completeness of the contents of this document and reserves the right to make changes to specifications and product descriptions at any time without notice. Taoglas reserves all rights to this document and the information contained herein. Reproduction, use or disclosure to third parties without express permission is strictly prohibited.



# 1. Introduction



The FXP055.A.07.C.001 is a 2-in-1 embedded GNSS and Wi-Fi flexible PCB antenna designed to be widely used with modern Wi-Fi networks, including all Wi-Fi 2.4/5.8/7.125GHz and GNSS frequencies on the L1 Bands from 1560-1610MHz.

Typical Applications Include:

- Asset Tracking Systems
- Smart Home Devices
- Telemedicine Devices
- Gaming Devices
- Navigation Devices

By integrating both Wi-Fi and GNSS functionality into a single compact and flexible PCB easy to install design, the FXP055 offers an efficient and space-saving solution. It provides manufacturers and designers with the flexibility to incorporate advanced wireless connectivity and precise positioning capabilities into their products without the need for more than one antenna.

The FXP055 has excellent efficiency and isolation performance for Wi-Fi and GNSS applications. With a thickness of only 0.24mm, the FXP055 is an ideal solution for maintaining high performance with over 50% efficiency across all Wi-Fi bands and GNSS L1 bands, while fitting into narrow spaces such as plastic enclosures for routers, gateways, set-top boxes, and other Wi-Fi and GNSS applications.

With its versatility and compatibility with a wide range of Wi-Fi networks, including the latest standards, as well as its support for GNSS frequencies, the FXP055 is a highly desirable choice for various wireless applications, from smart home devices and IoT devices to industrial equipment and navigation systems.

For further optimization to customer-specific device environments and for support to integrate and test this antennas performance in your device, please contact your regional Taoglas Customer Support Team.

## 2. Specification

GNSS Frequency Bands					
GPS	L1 1575.42 MHz	L2 1227.6 MHz	L5 1176.45 MHz		
	■	□	□		
GLONASS	G1 1602 MHz	G2 1248 MHz	G3 1207 MHz		
	■	□	□		
Galileo	E1 1575.24 MHz	E5a 1176.45 MHz	E5b 1201.5 MHz	E6 1278.75 MHz	
	■	□	□	□	
BeiDou	B1C 1575.42 MHz	B1I 1561 MHz	B2a 1176.45 MHz	B2b 1207.14 MHz	B3 1268.52 MHz
	■	■	□	□	□
QZSS (Regional)	L1 1575.42 MHz	L2C 1227.6 MHz	L5 1176.45 MHz	L6 1278.75e6	
	■	□	□	□	
IRNSS (Regional)	L5 1176.45 MHz				
	□				
SBAS	L1/E1/B1 1575.42 MHz	L5/B2a/E5a 1176.45 MHz	G1 1602 MHz	G2 1248 MHz	G3 1207 MHz
	■	□	■	□	□

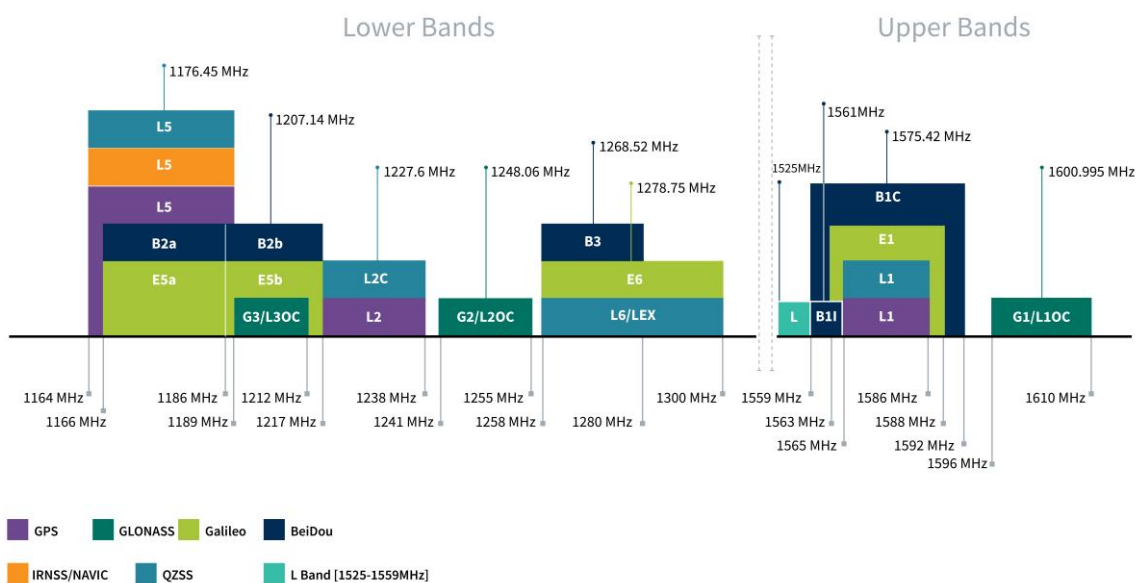

GNSS Electrical								
Band	Frequency (MHz)	Efficiency (%)	Average Gain (dB)	Peak Gain (dBi)	Impedance	Polarization	Radiation Pattern	Max. input power
L1 [1575.42 MHz]	1565-1586	74.8	-1.26	2.14	50 Ω	Linear	Omni	2W
G1/L1OC [1601 MHz]	1596-1610	71.7	-1.44	1.92				
B1I [1561 MHz]	1559-1565	75.0	-1.25	2.16				

Wi-Fi Electrical								
Band	Frequency (MHz)	Efficiency (%)	Average Gain (dB)	Peak Gain (dBi)	Impedance	Polarization	Radiation Pattern	Max. input power
WiFi - 2GHz	2400-2500	56.8	-2.46	2.56	50 Ω	Linear	Omni	2W
WiFi - 5GHz	5150-5850	58.2	-2.35	4.88				
WiFi - 6GHz	5925-7125	66.0	-1.80	6.88				

Mechanical	
Dimensions	53*18*0.24mm
Material	Polymer
Connector	IPEX MHFI U.FL Compatible
Cable	1.37mm Coaxial Cable

Environmental	
Operation Temperature	-40°C to +85°C
RoHs & REACH Compliant	Yes

### 3. Antenna Characteristics

#### 3.1 Test Setup

AUT

Vector Network Analyzer



### 3.2 GNSS - Return Loss

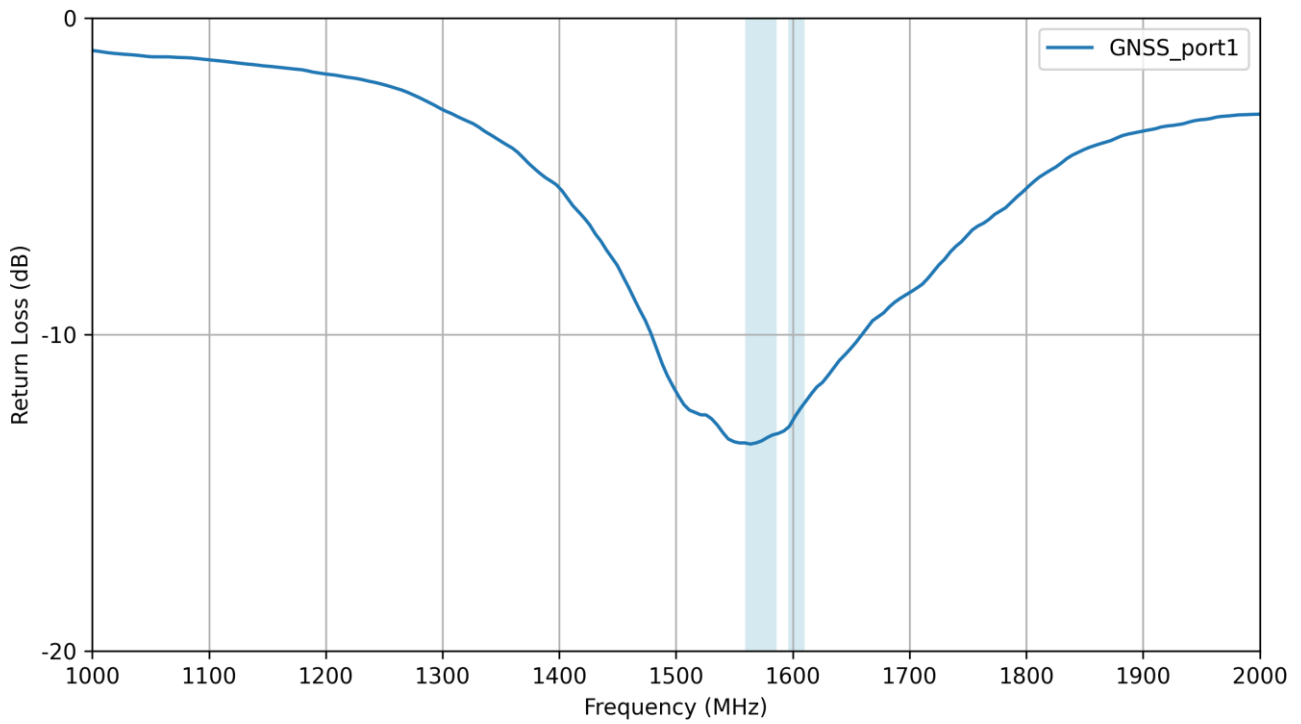

### 3.3 GNSS - VSWR

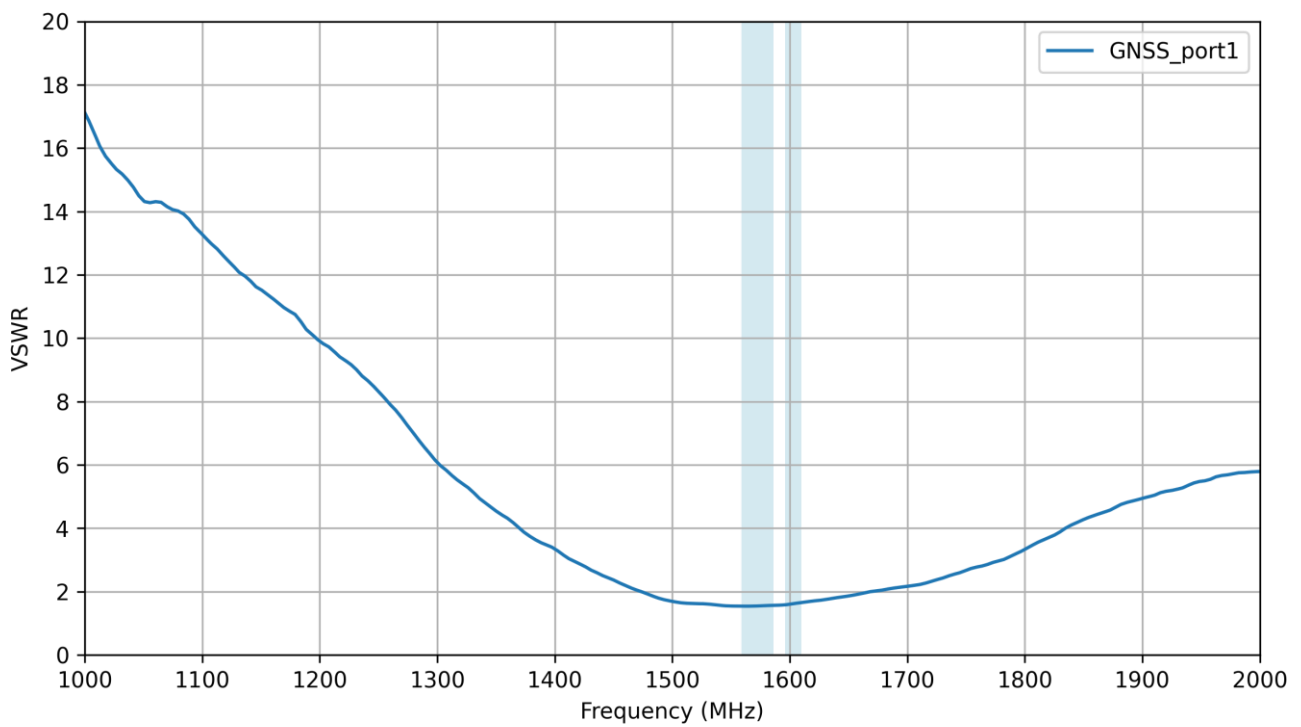

### 3.4 GNSS - Efficiency

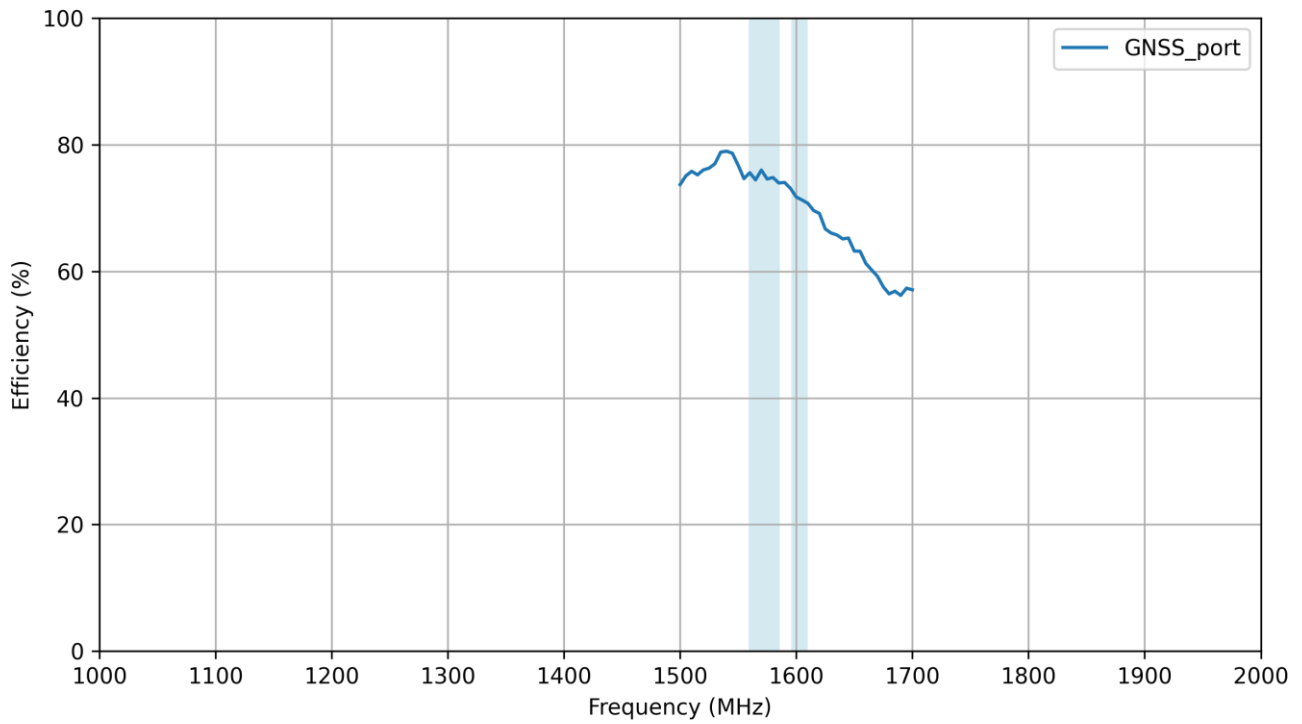

### 3.5 GNSS - Average Gain

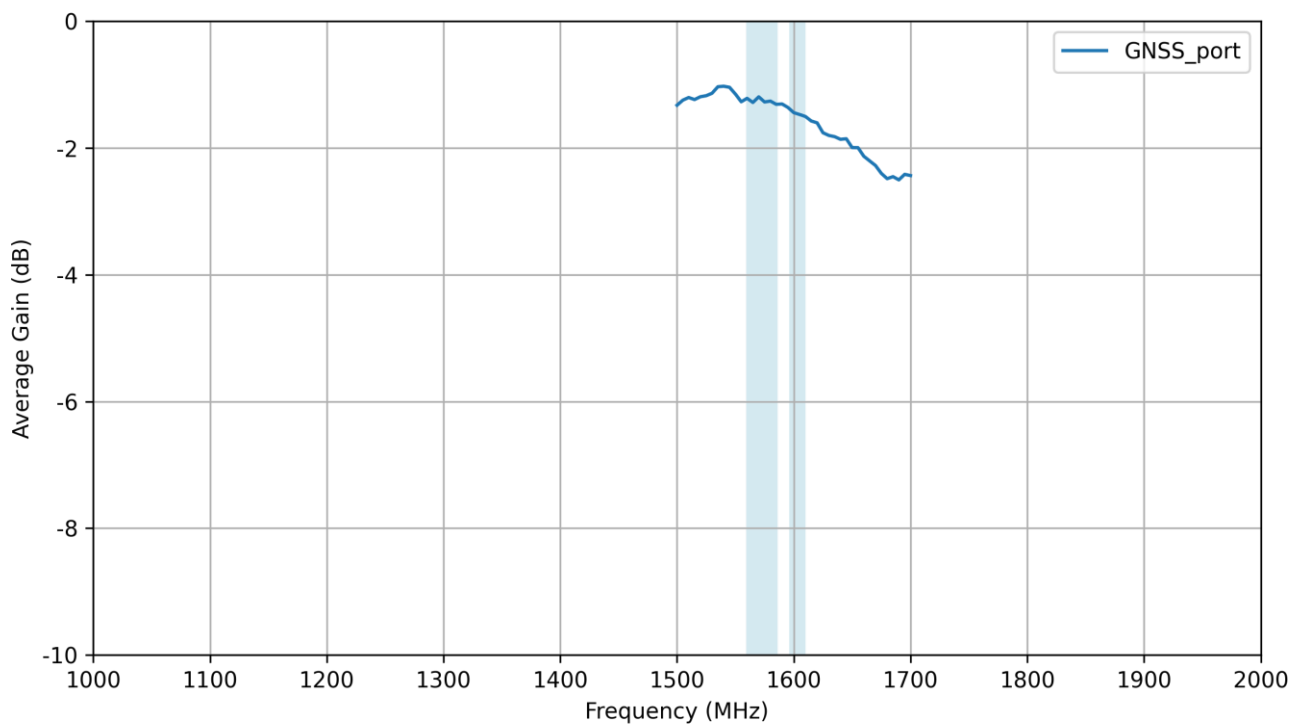



### 3.6 GNSS - Peak Gain

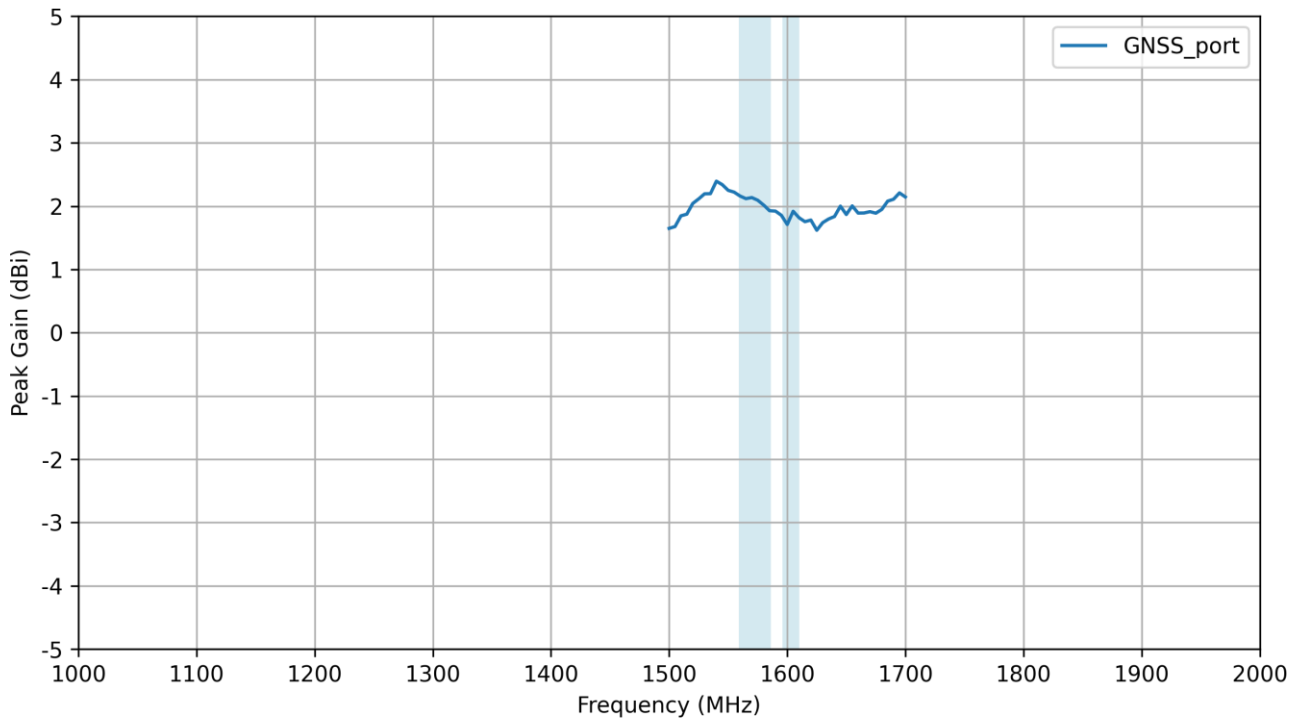

### 3.7 Wi-Fi - Return Loss

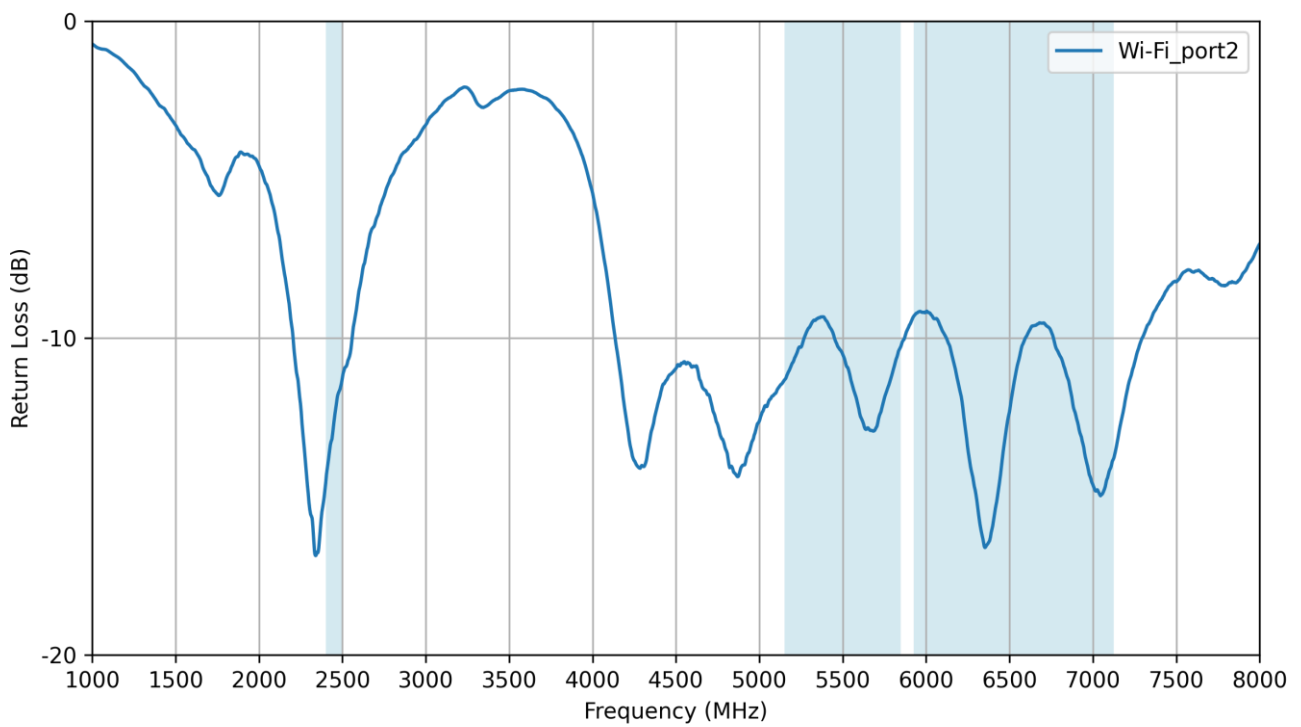

### 3.8 Wi-Fi - VSWR

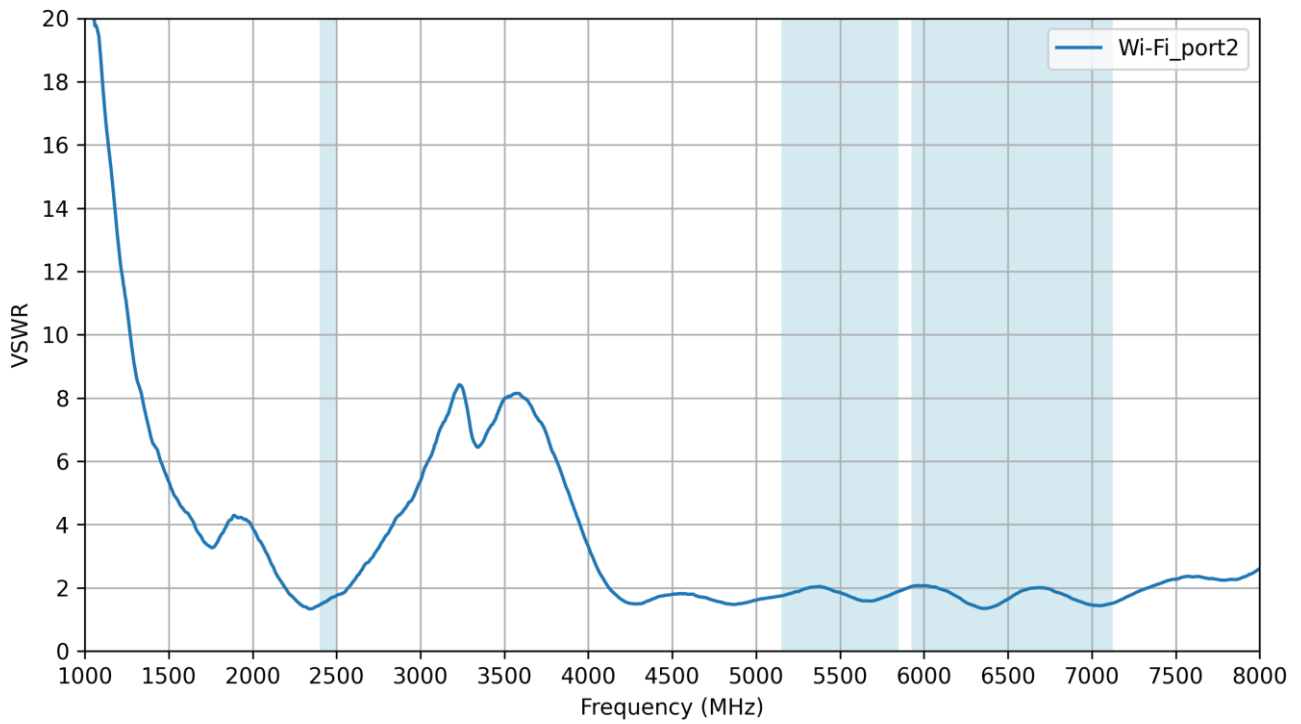

### 3.9 Wi-Fi – GNSS Isolation

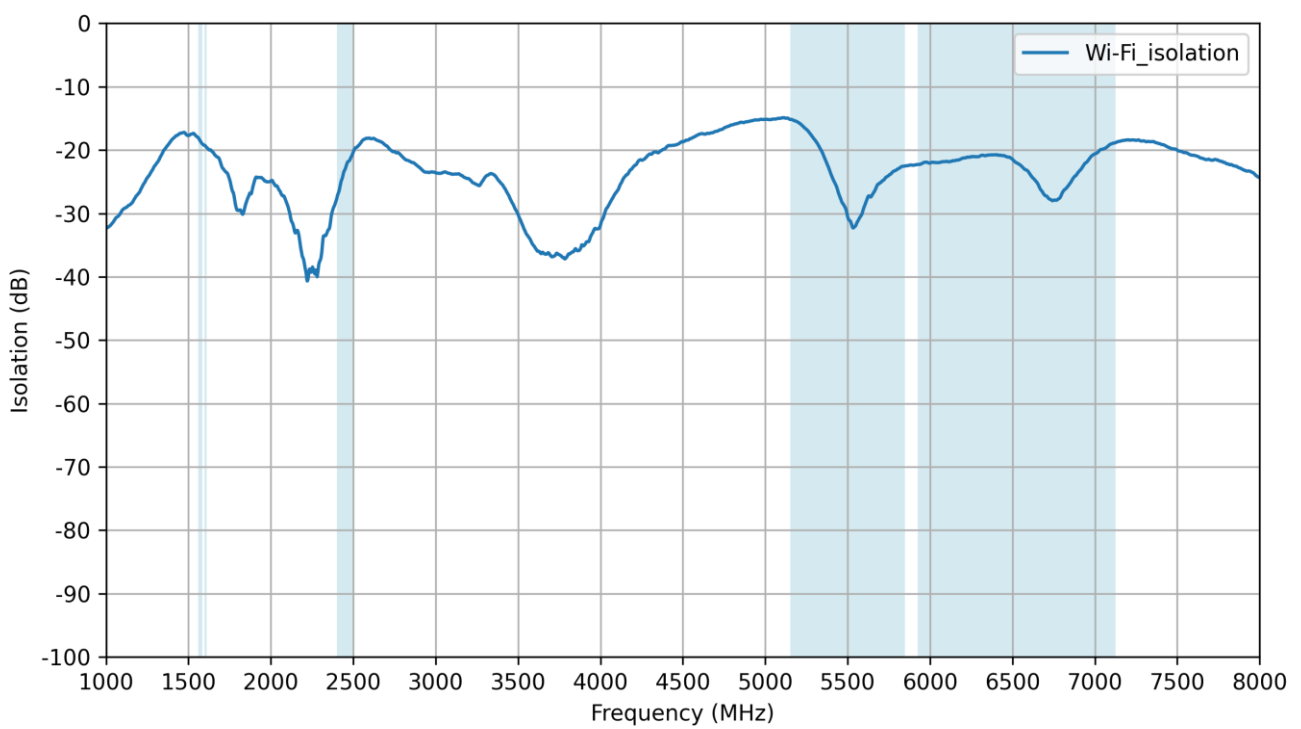

### 3.10 Wi-Fi - Efficiency

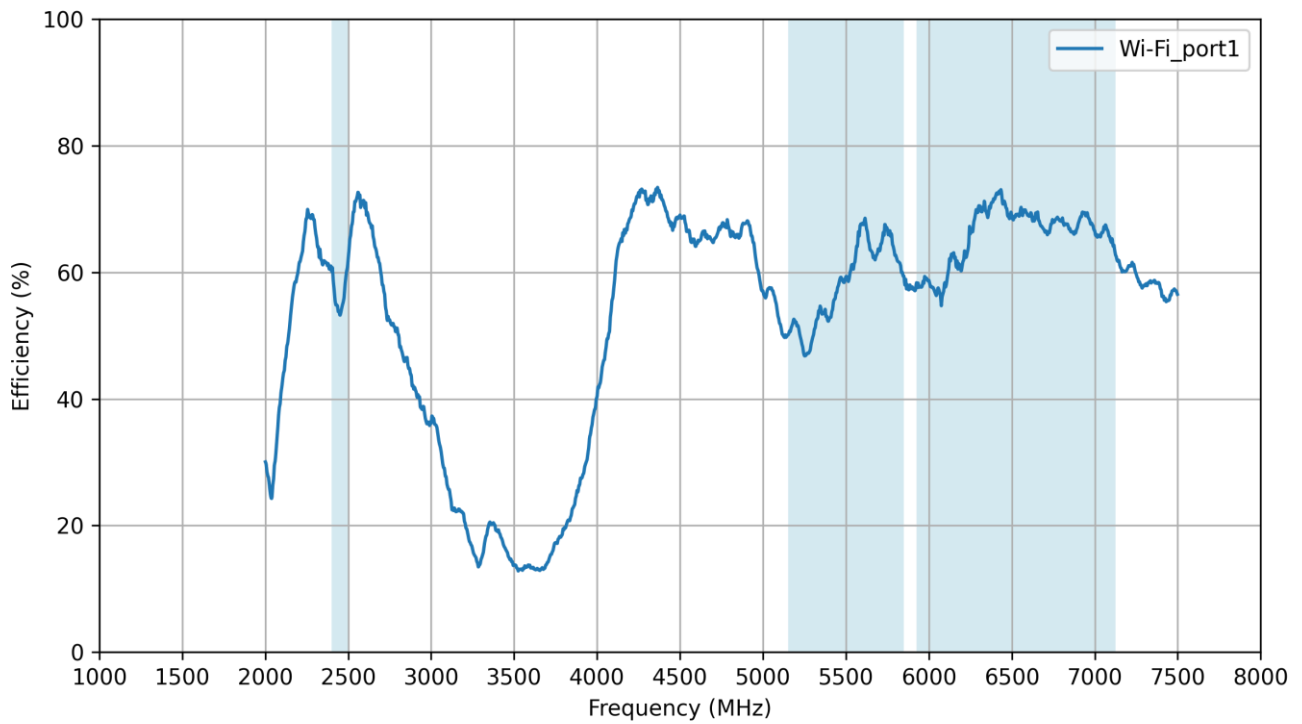

### 3.11 Wi-Fi - Average Gain

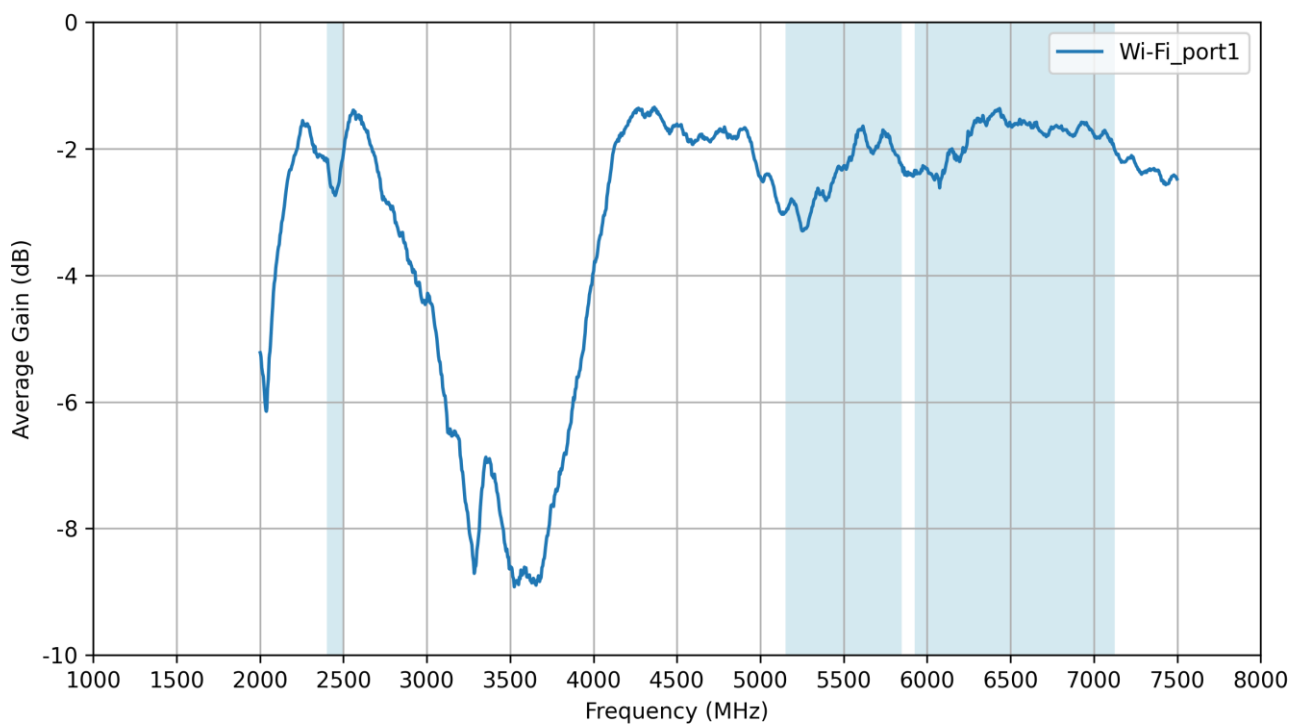

### 3.12 Wi-Fi - Peak Gain

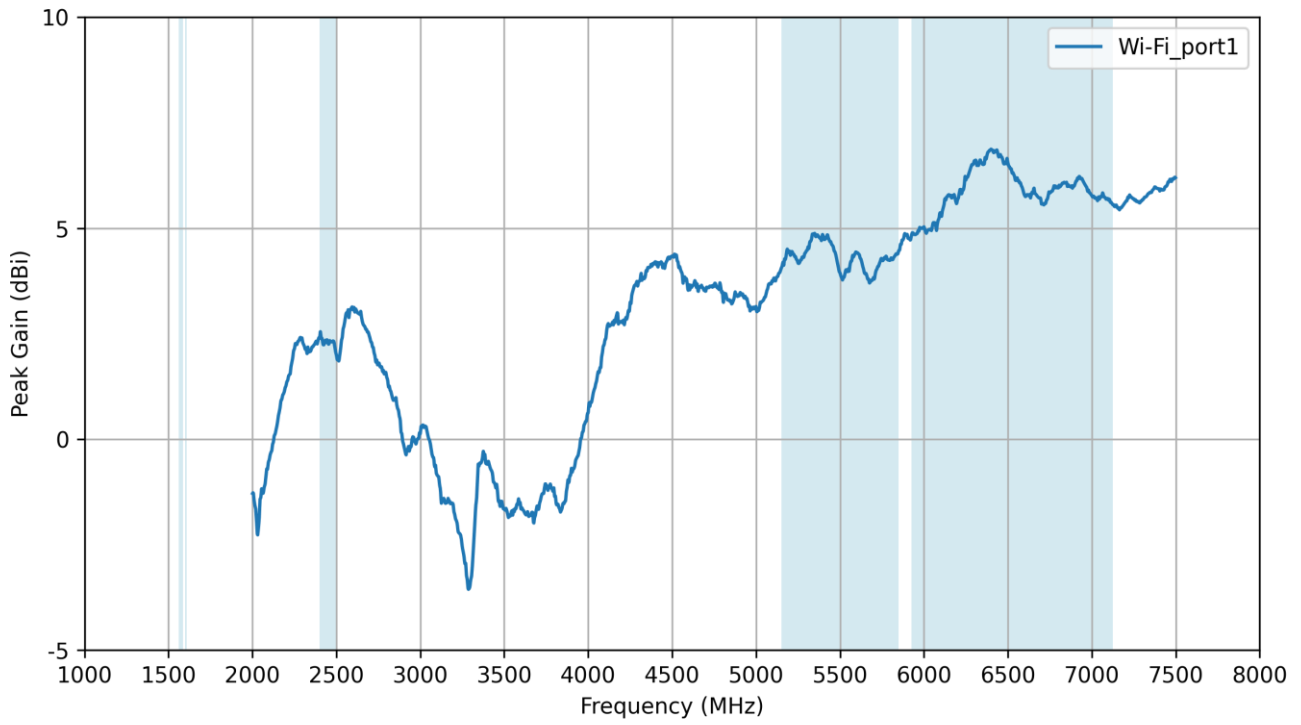

## 4. Radiation Patterns

### 4.1 Test Setup

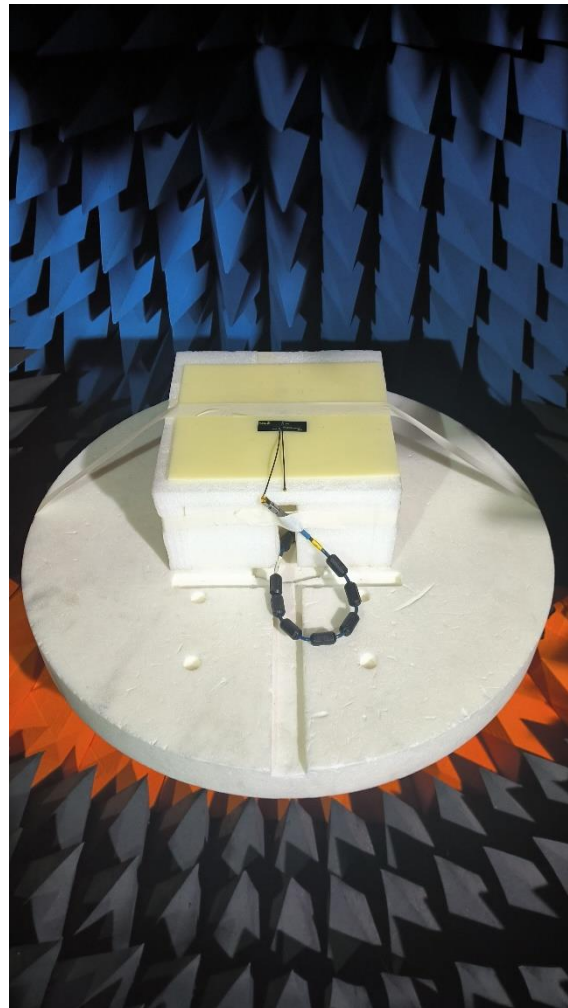
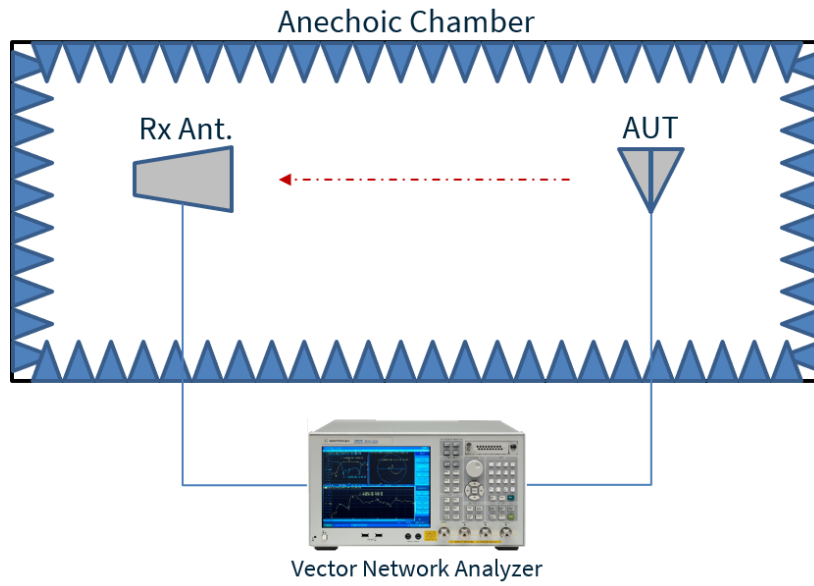

4.2 GNSS port Patterns at 1575 MHz

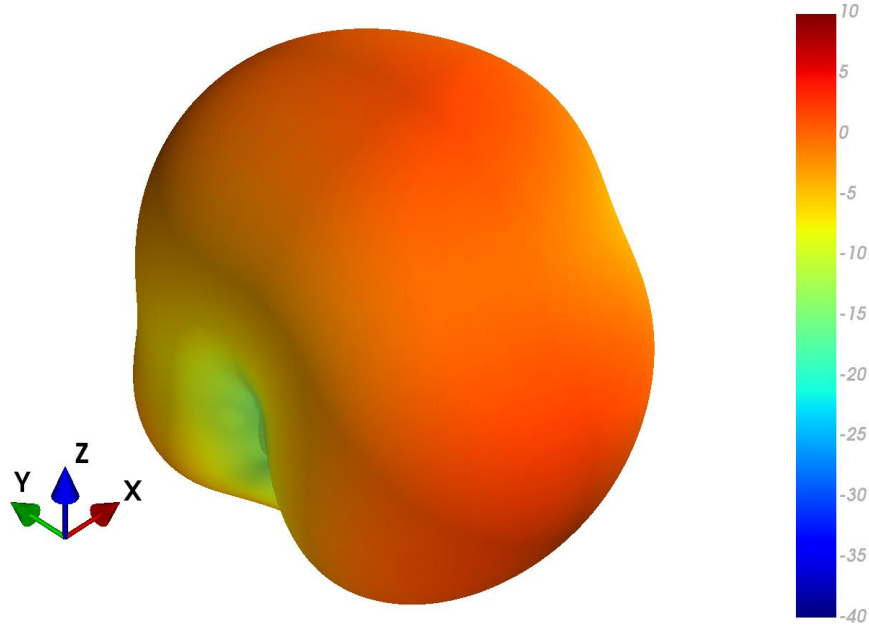

XZ Plane                      YZ Plane                      XY Plane

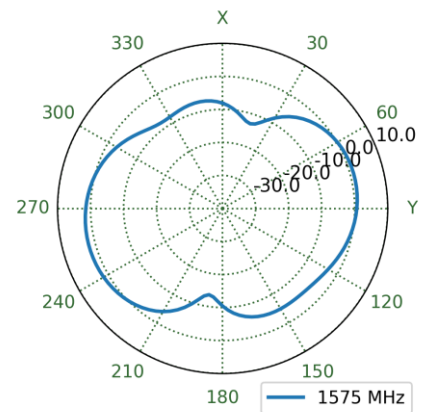
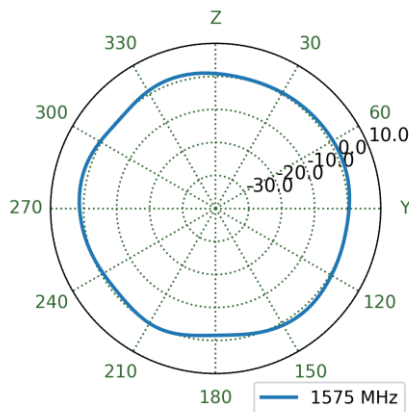
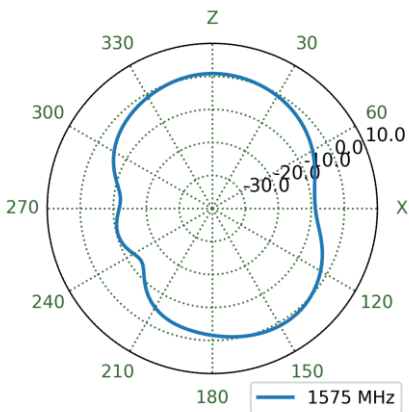

4.3 GNSS port Patterns at 1605 MHz

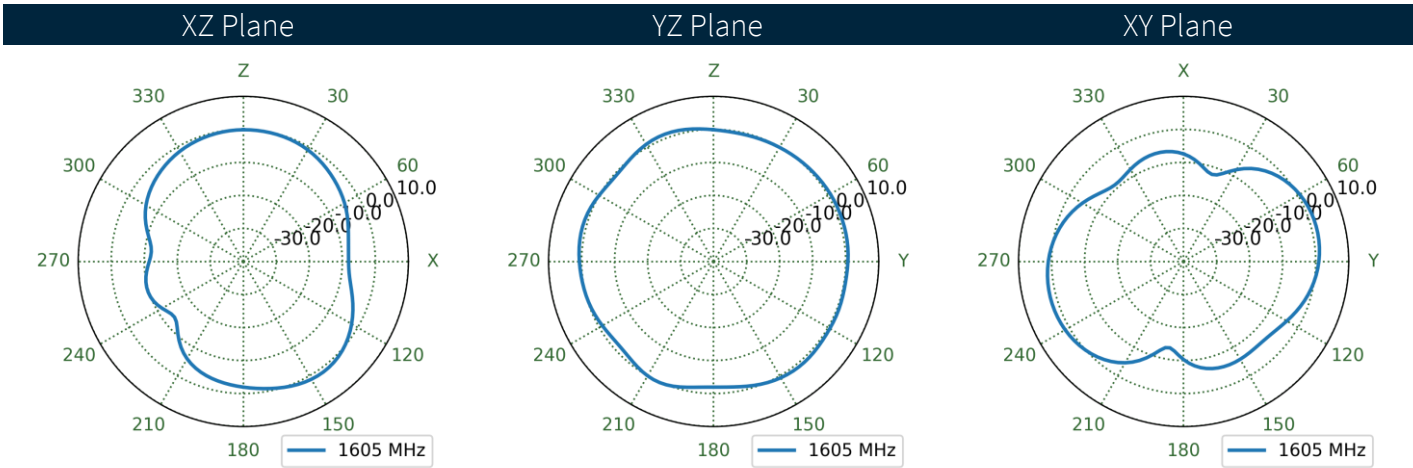
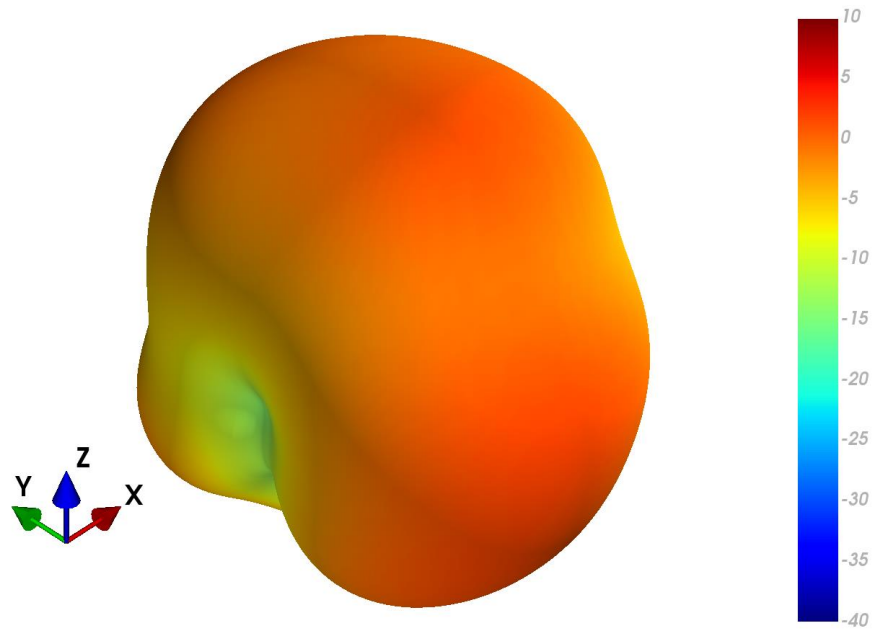

4.4 GNSS port Patterns at 1560 MHz

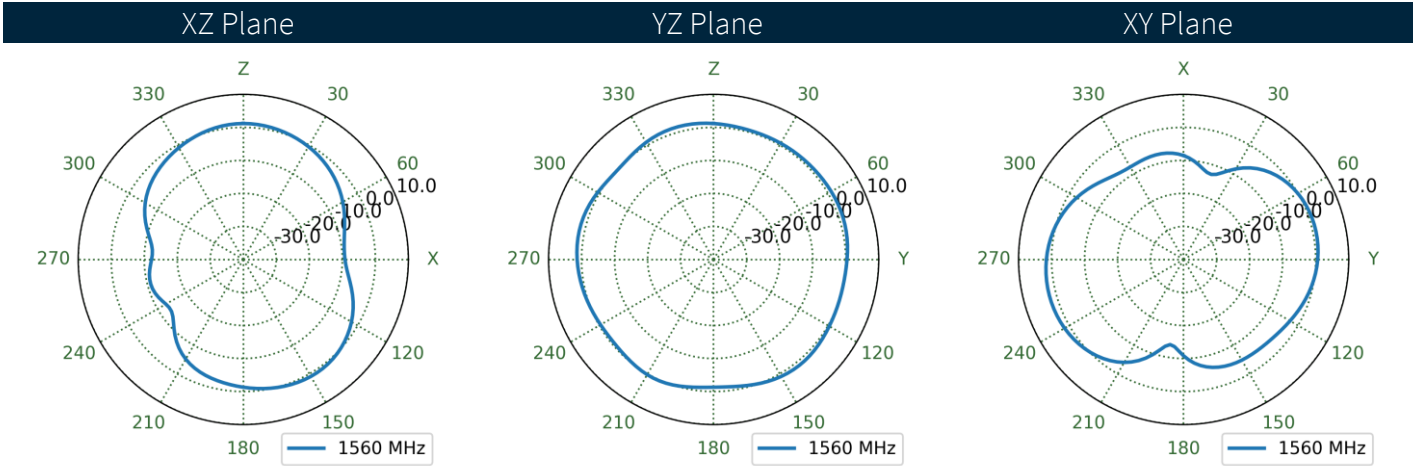
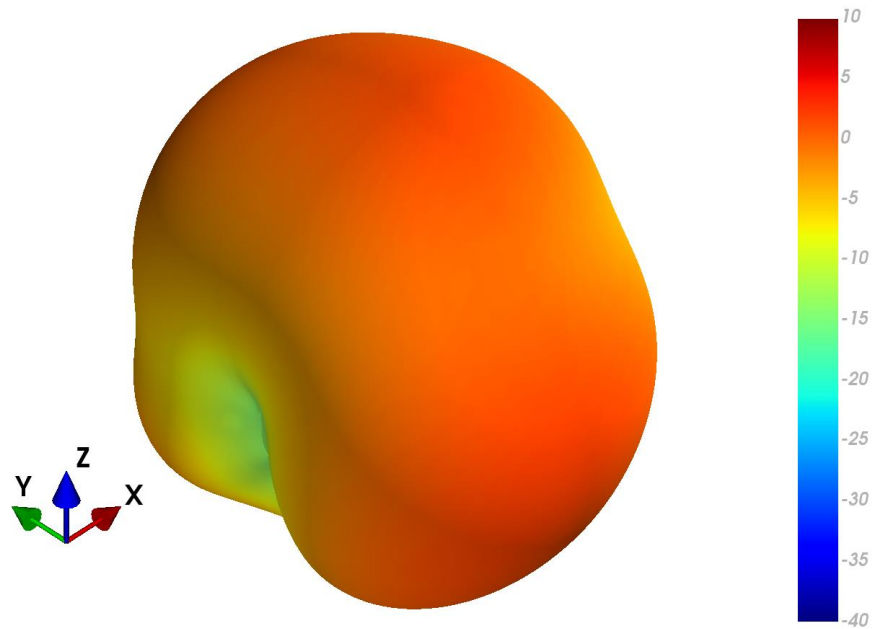



4.5 Wi-Fi\_port1 Patterns at 2450 MHz

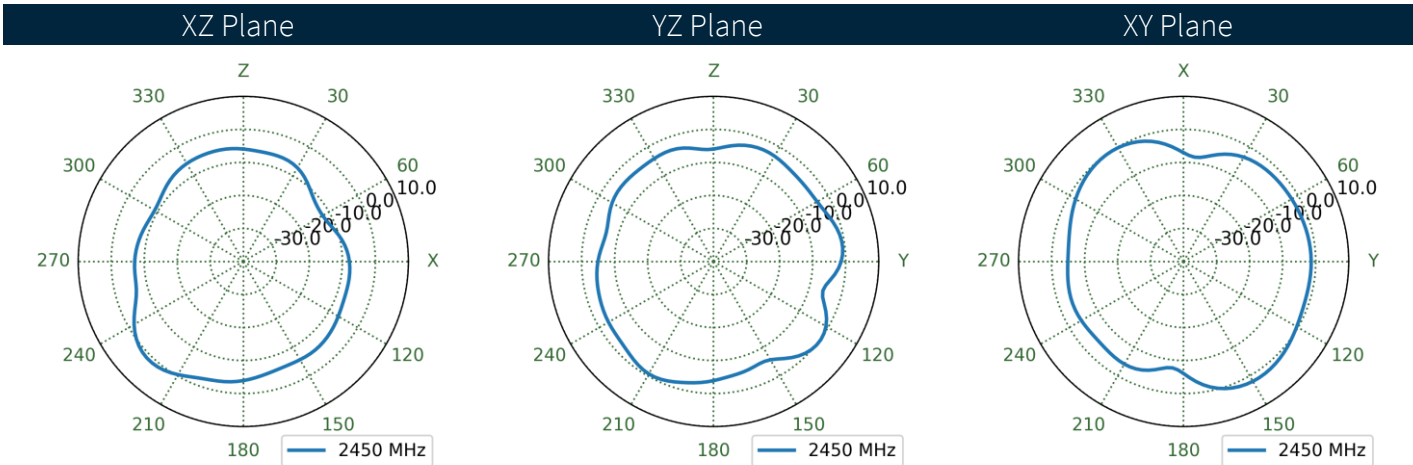
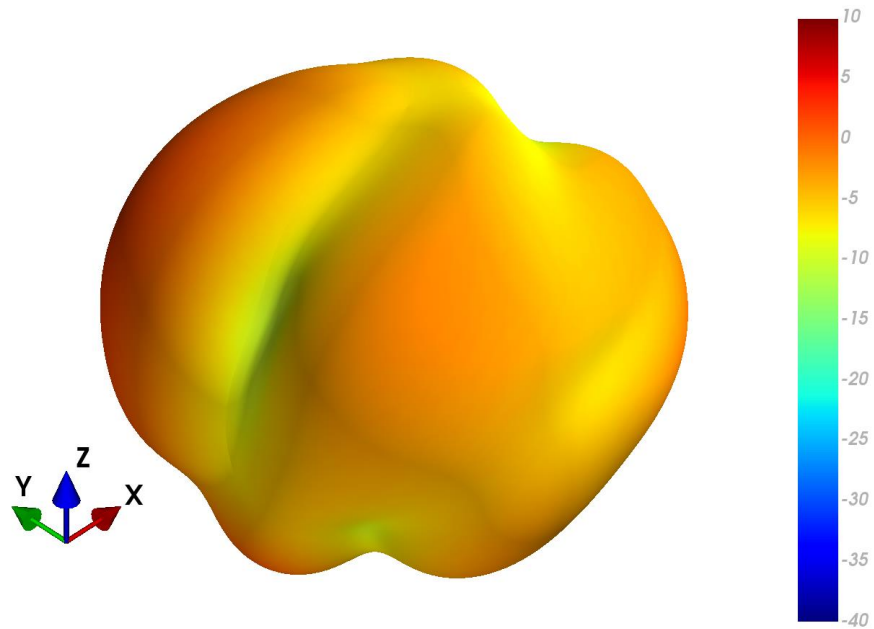

4.6 Wi-Fi\_port1 Patterns at 5500 MHz

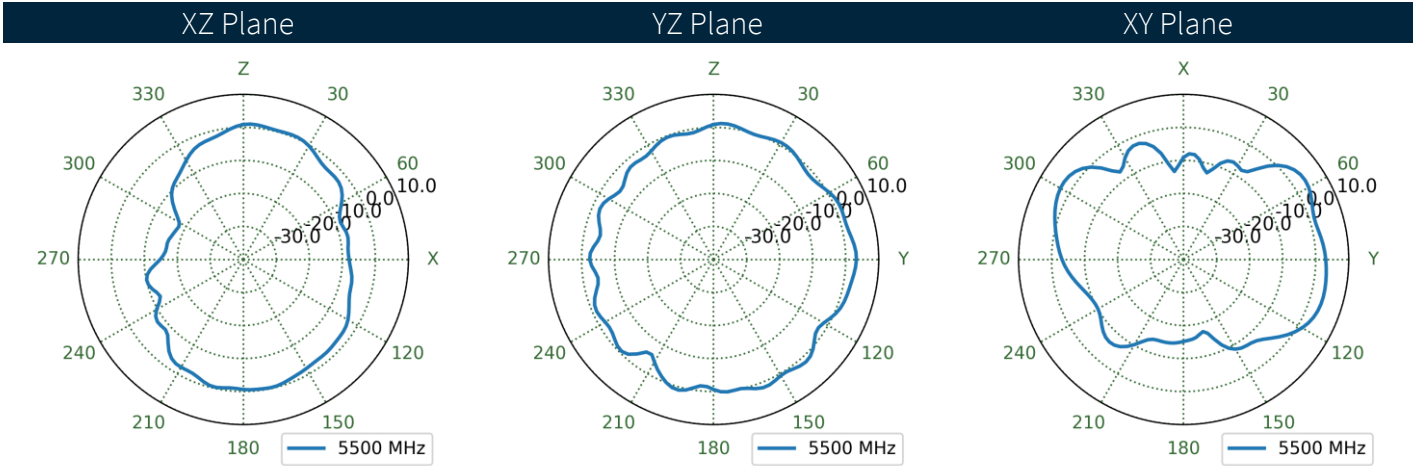
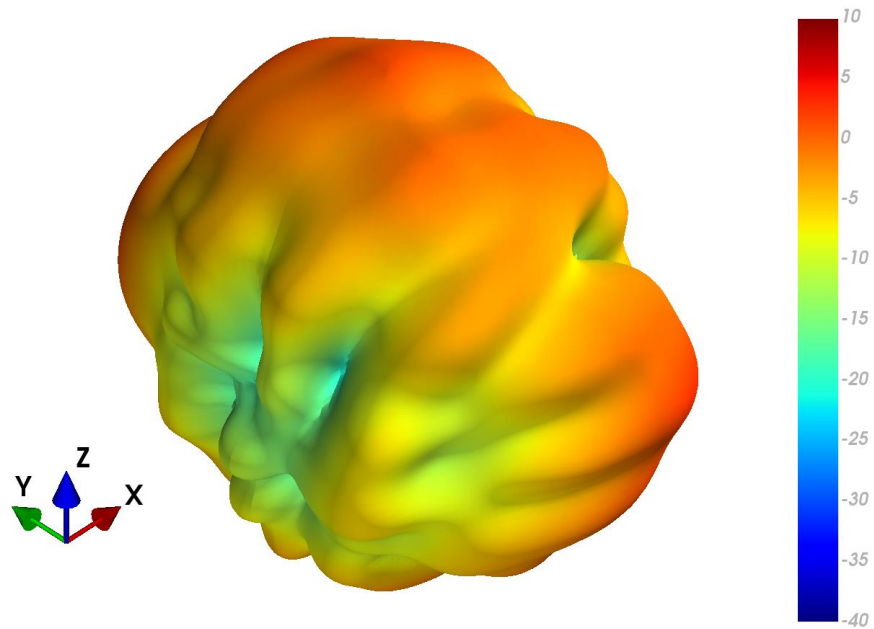

4.7 Wi-Fi\_port1 Patterns at 7125 MHz

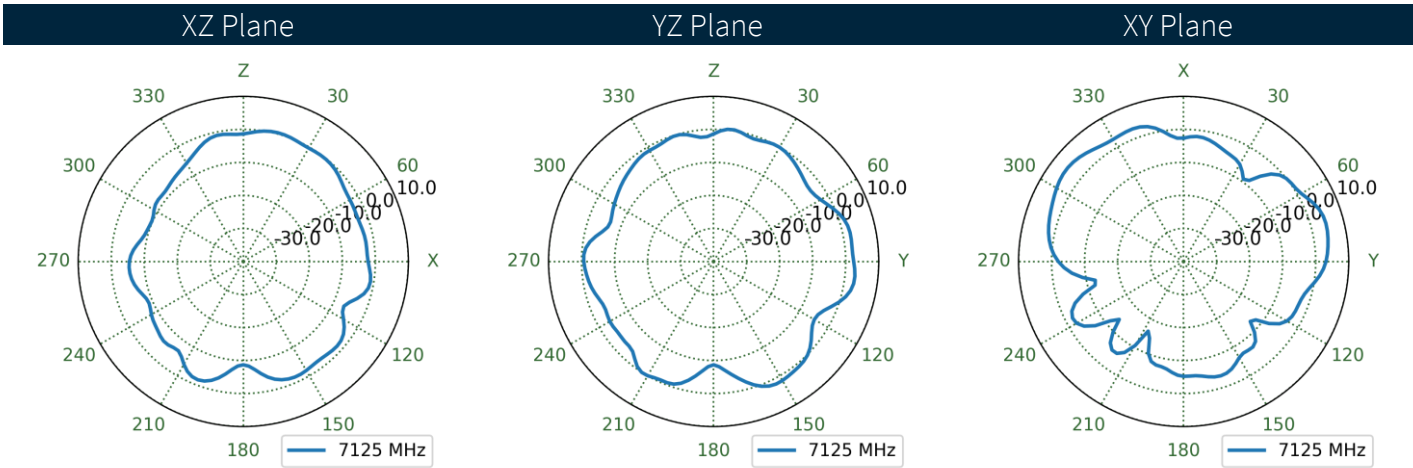
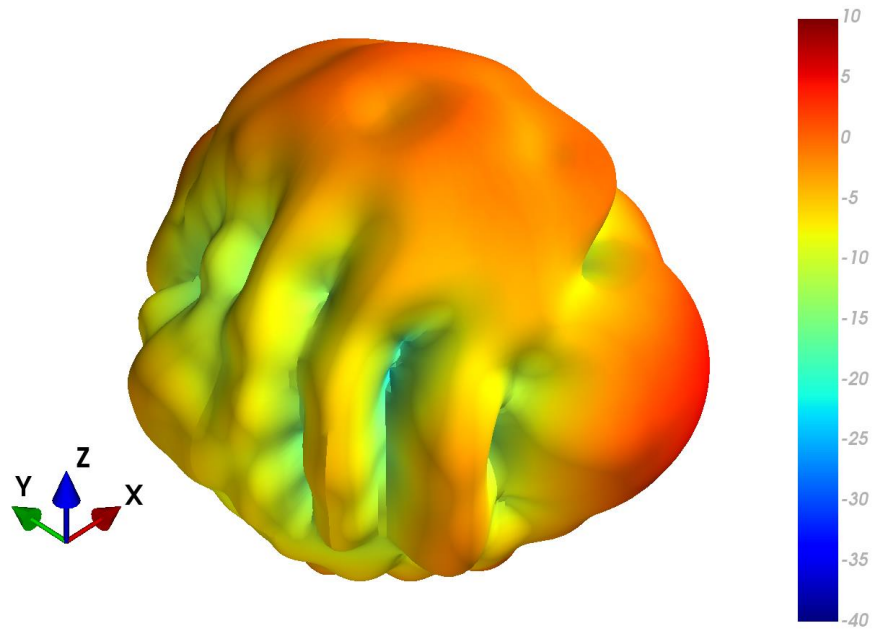

# 5. Mechanical Drawing

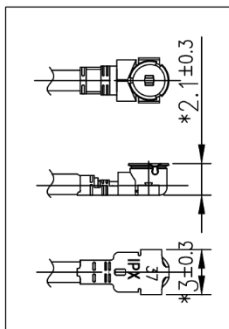
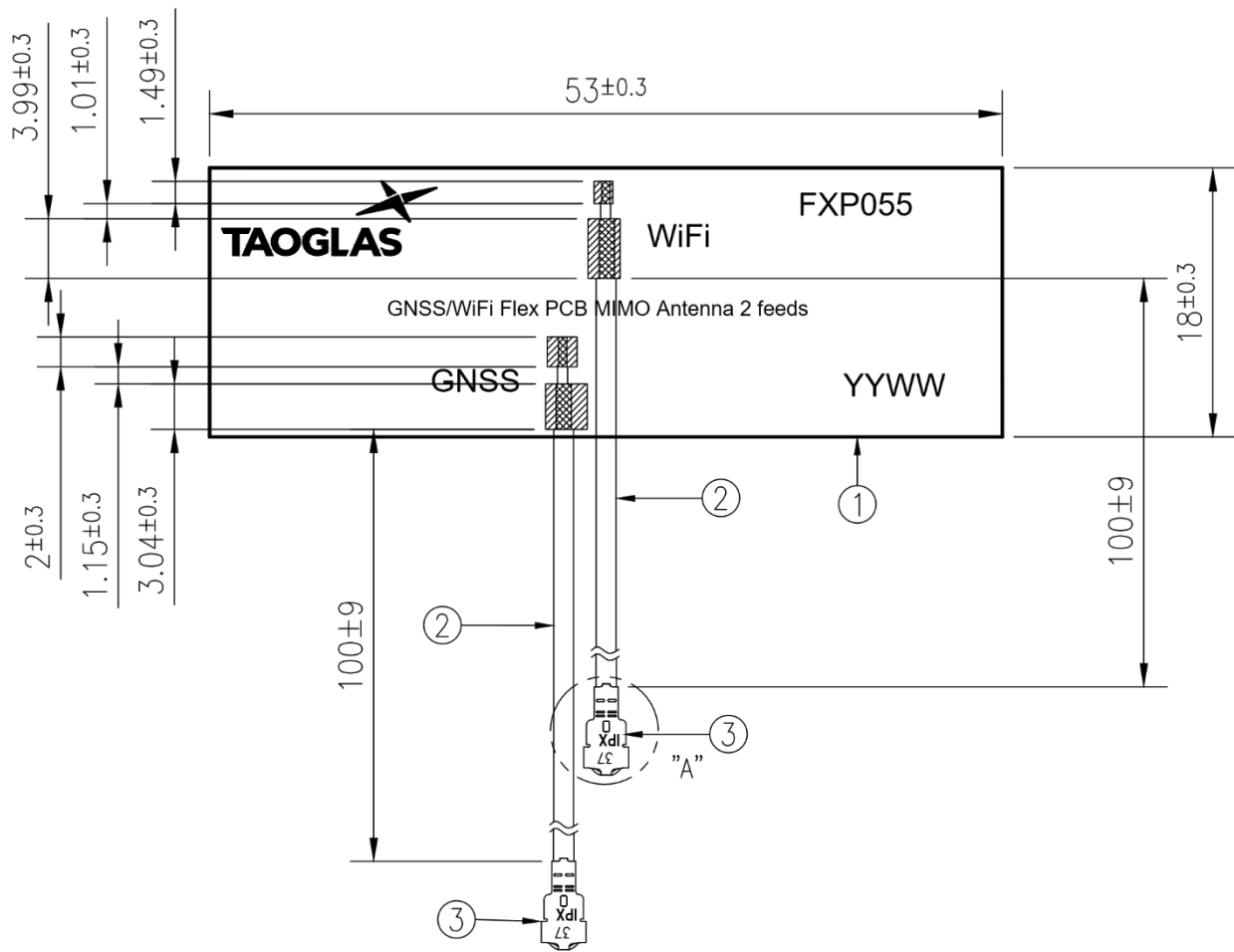

Detail A  
Scale:2:1

	Name	Material	Finish	QTY
1	FXP055 FPC	FPCB 0.24t	Black	1
2	1.37 Coaxial Cable	FEP	Black	2
3	PEX MHFI	Brass	Gold	2

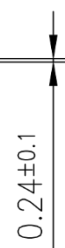

## 6. Packaging

FXP055.A.07.C.001  
100 pcs / PE Bag



5000 pcs / Carton  
Carton(mm): 320x230x250

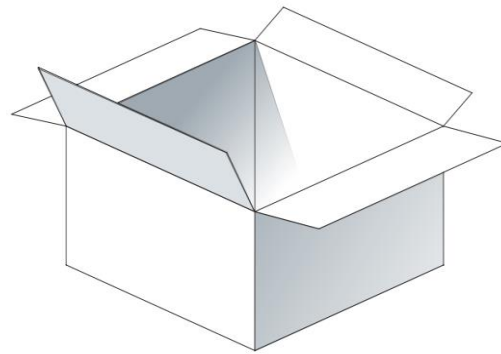

Changelog for the datasheet

**SPE-23-8-119 - FXP055.A.07.C.001**

**Revision: A (Original First Release)**

Date:	2023-06-19
Changes:	
Author:	Cesar Sousa

**Previous Revisions**



[www.taoglas.com](http://www.taoglas.com)

