



TAOGLAS®



Datasheet

2.4GHz Mini Monopole Antenna

Part No:
GW.23.A151

Description

2.4GHz Mini Monopole Antenna RP-SMA(M) Straight

Features:

- 2.4GHz Band Operation
- Small Factor
- IP67 Rated Enclosure
- RP-SMA(M) Straight Connector
- Dimensions: \varnothing 8.9mm x 21mm
- RoHS & Reach Compliant

1.	Introduction	2
2.	Specification	3
3.	Antenna Characteristics	4
4.	Radiation Patterns	7
5.	Mechanical Drawing	11
6.	Packaging	12
<hr/>		
	Changelog	13

Taoglas makes no warranties based on the accuracy or completeness of the contents of this document and reserves the right to make changes to specifications and product descriptions at any time without notice. Taoglas reserves all rights to this document and the information contained herein. Reproduction, use or disclosure to third parties without express permission is strictly prohibited.



1. Introduction



The GW.23 is one of a range of super small form factor, lightweight, IP67 rated terminal mount antennas from Taoglas. It is ideal for wireless applications operating on Bluetooth and Wireless LAN bands covering 2.4GHz. Its robust silicone enclosure is engineered to perform in the most challenging of external environments when connecting IoT devices to smart grid and smart monitoring applications.

With its IP67 rating, the GW.23 can withstand dust, dirt, and even complete submersion in water, making it the perfect choice for any IoT application that demands both reliable connectivity and extreme durability. Whether you're connecting sensors for remote agricultural, monitoring equipment in industrial settings, or building the infrastructure for smart cities, the GW.23 is a great solution.

If you are looking for an antenna that's small, tough, and versatile, look no further than the GW.23. Contact your regional Taoglas Customer Services Team for more information or to discuss your project.

2. Specification

Wi-Fi Electrical								
Band		Efficiency (%)	Average Gain (dB)	Peak Gain (dBi)	Impedance	Polarization	Radiation Pattern	Power consumption
Wi-Fi 2.4 GHz	In Free space	23.2	-6.35	-1.41	50 Ω	Linear	Omni	10W
	On 15x9cm Ground plane (Long side)	65.1	-1.86	3.78				
	On 9x15cm Ground plane (Short side)	63.7	-1.96	4.72				

Mechanical	
Dimensions	21mm x ø8.9mm
Weight	3.3g
Material	Silicone
Connector	RP-SMA(M)

Environmental	
Operating Temperature	-40°C ~ +85°C
Waterproof Rating	IP67

3. Antenna Characteristics

3.1 Test Setup

AUT



Vector Network Analyzer



In Free Space

On 15x9cm Ground plane

On 9x15cm Ground plane

3.2 Return Loss

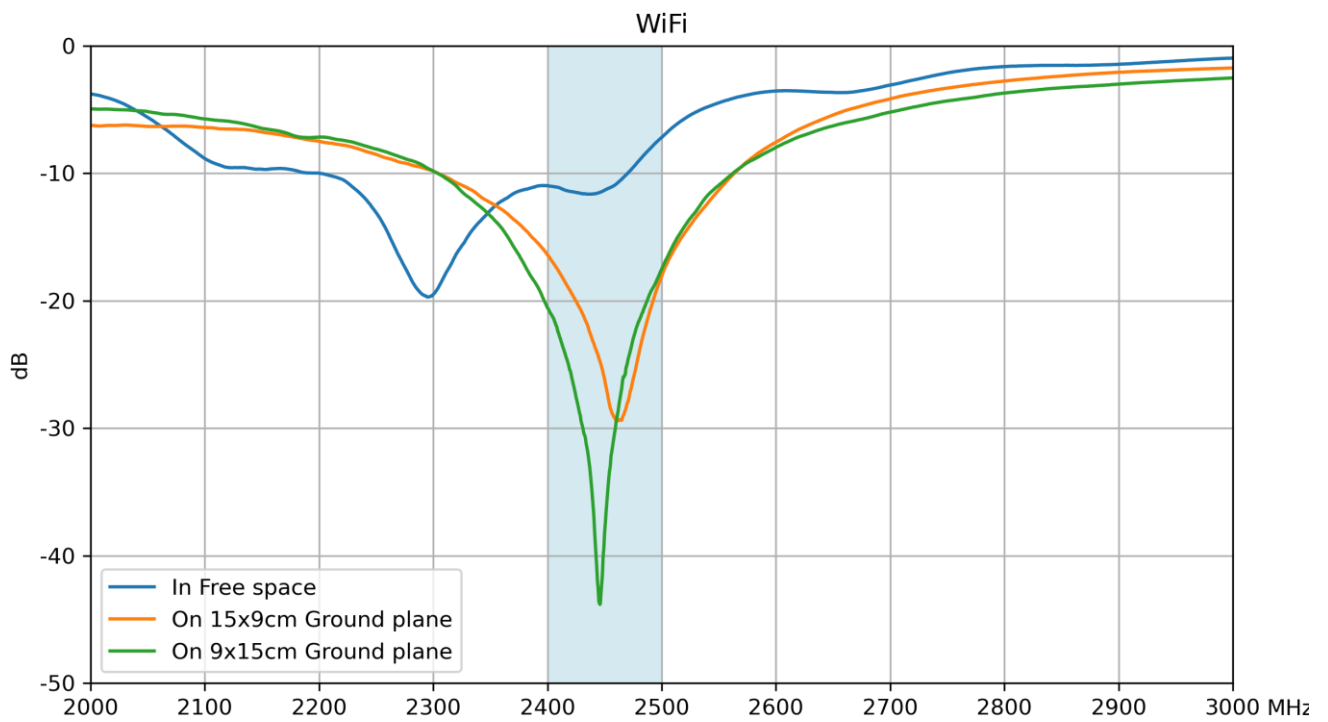

3.3 Efficiency

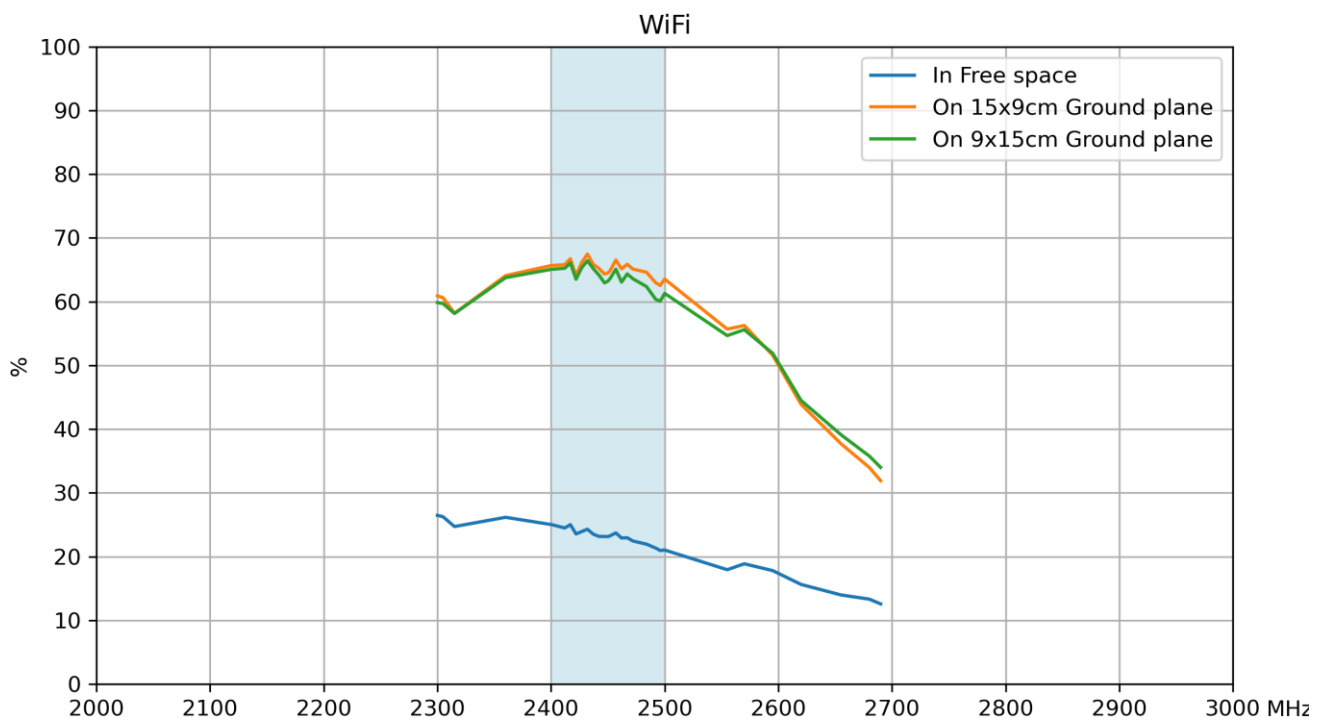

3.4 Average Gain

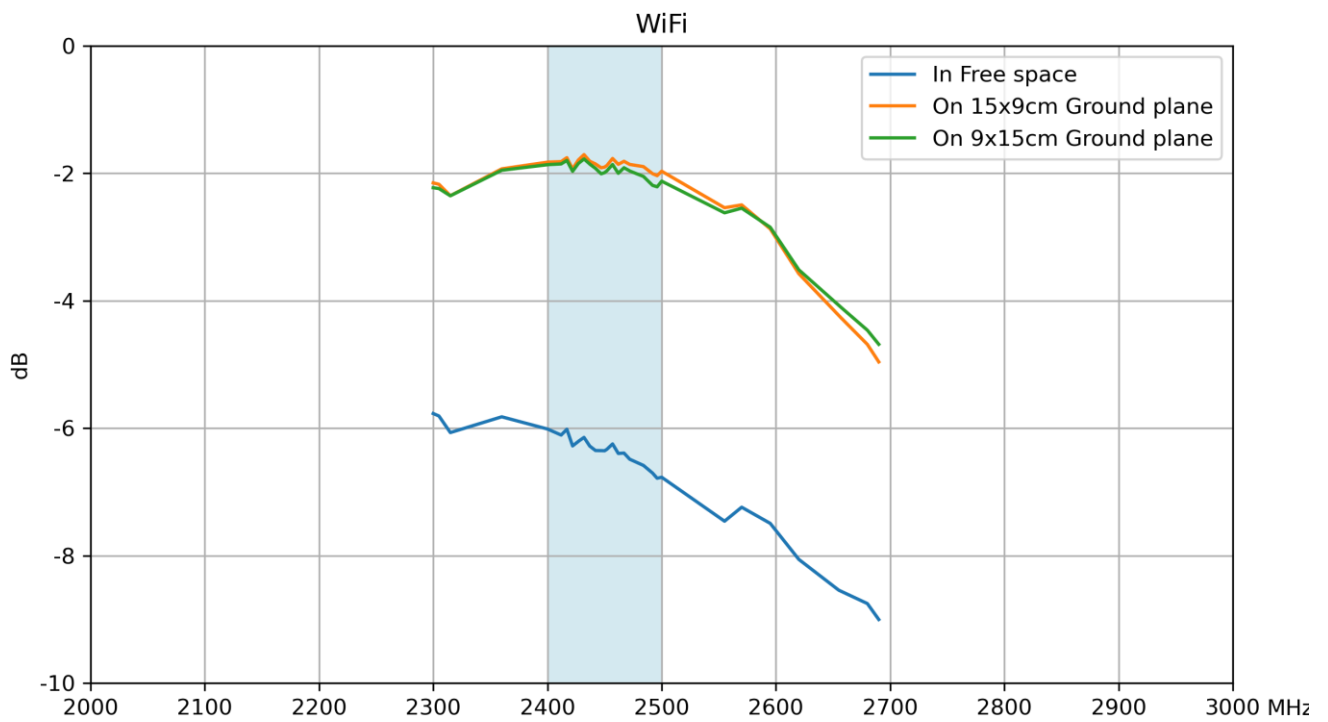

3.5 Peak Gain

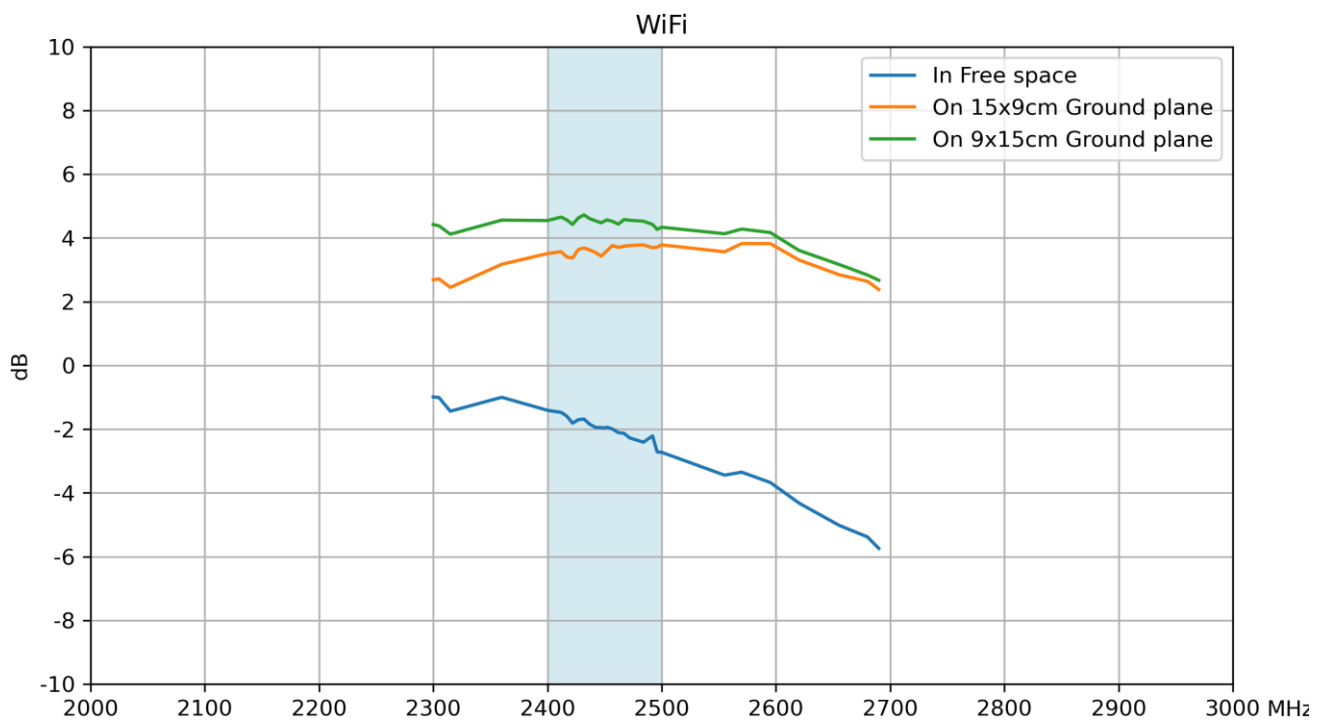

4. Radiation Patterns

4.1 Test Setup

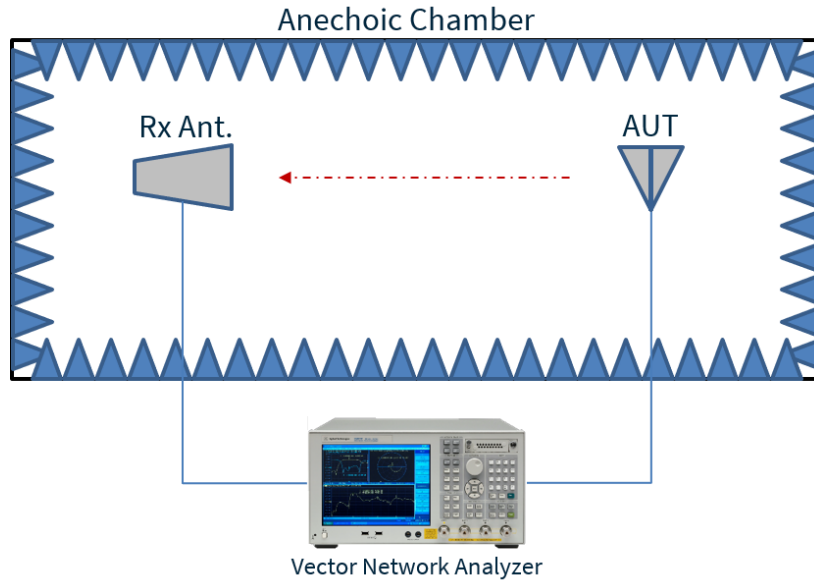

In Free Space

On 15x9cm Ground plane

On 9x15cm Ground plane

4.2 GW.23.A151 - Patterns at 2450 MHz in Free Space

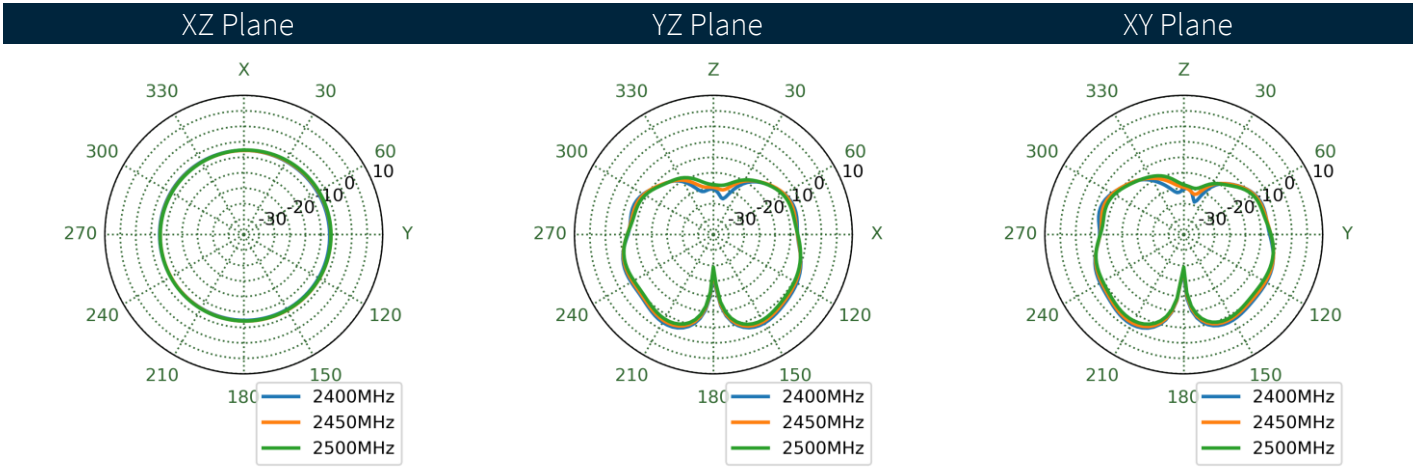
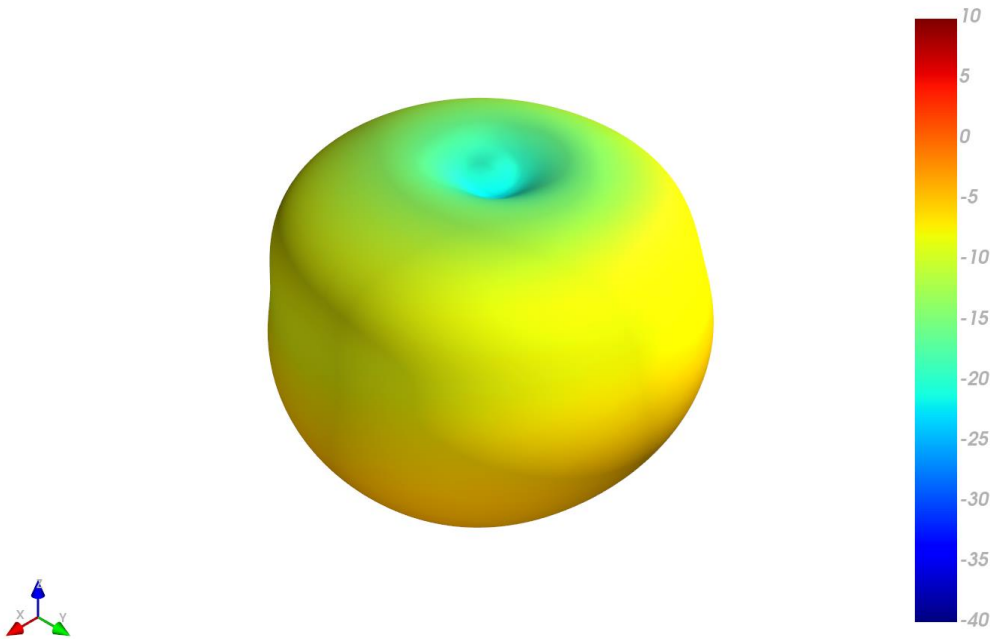

4.3 GW.23.A151 - Patterns at 2450 MHz on 15x9cm ground plane

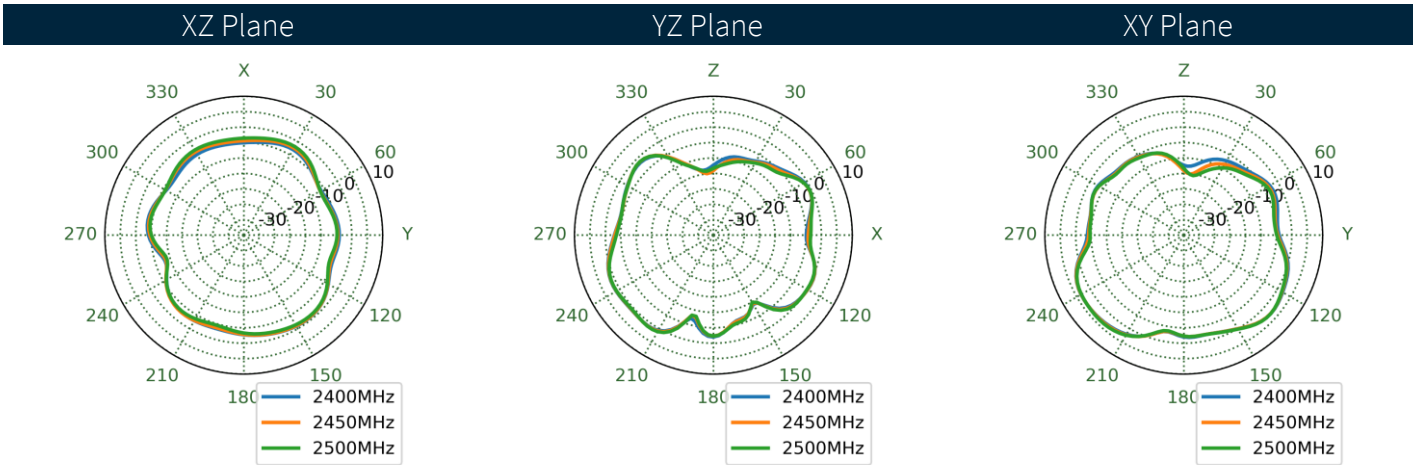
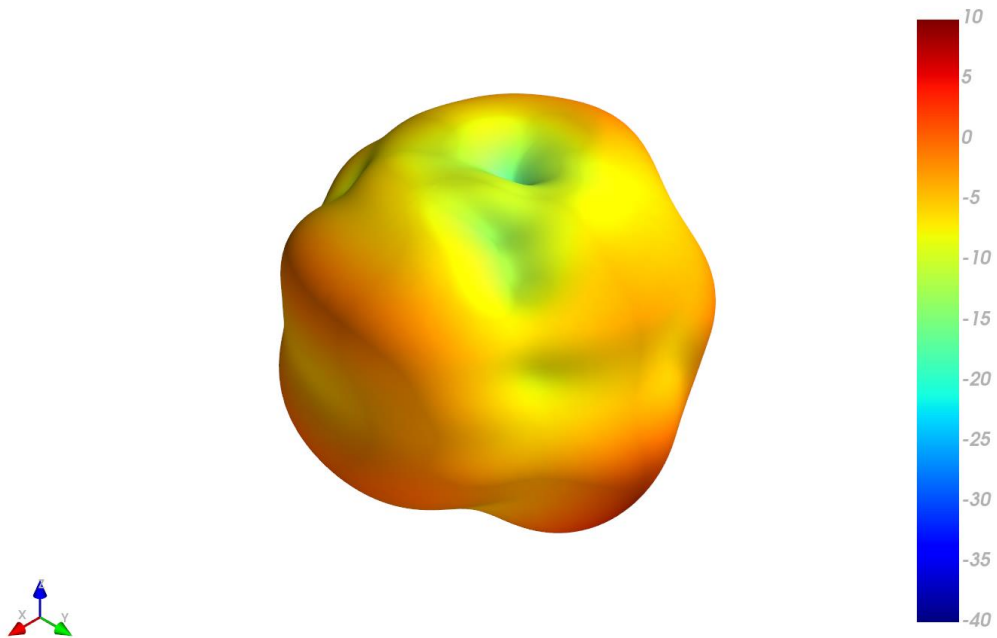

4.4 GW.23.A151 - Patterns at 2450 MHz on 9x15cm ground plane

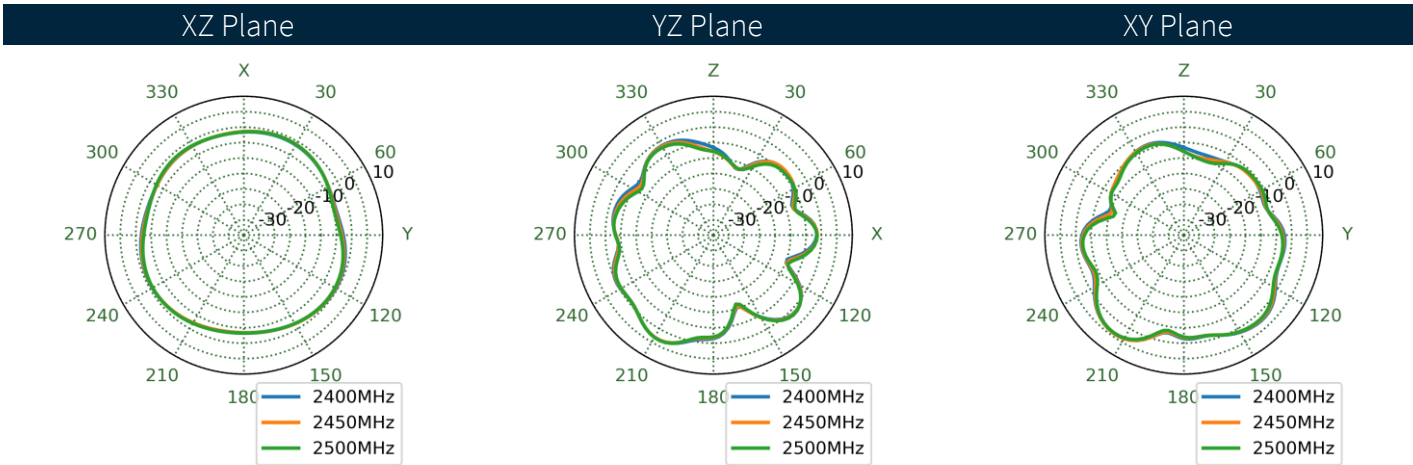
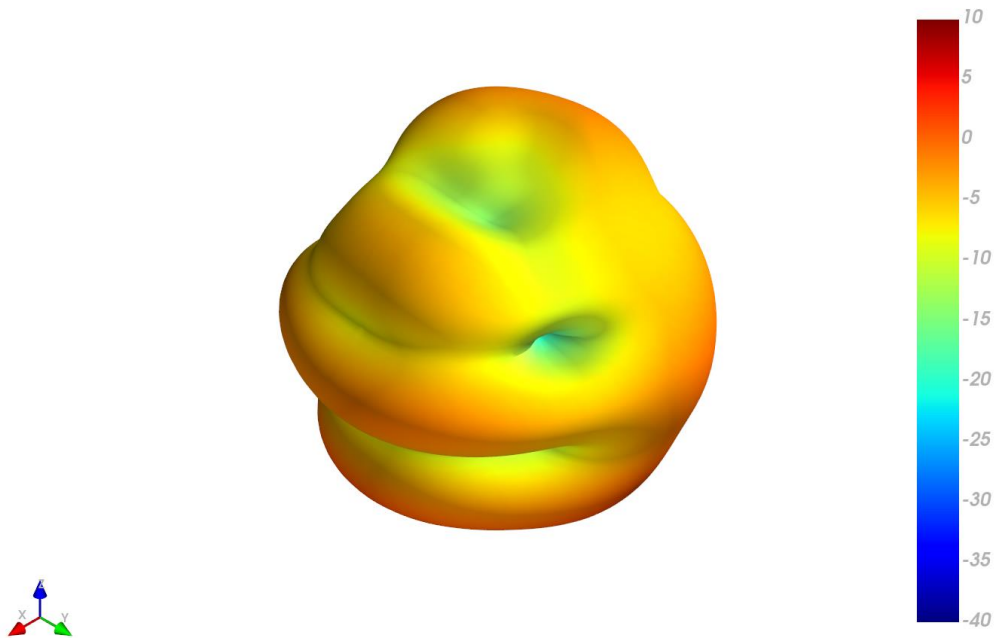

5. Mechanical Drawing

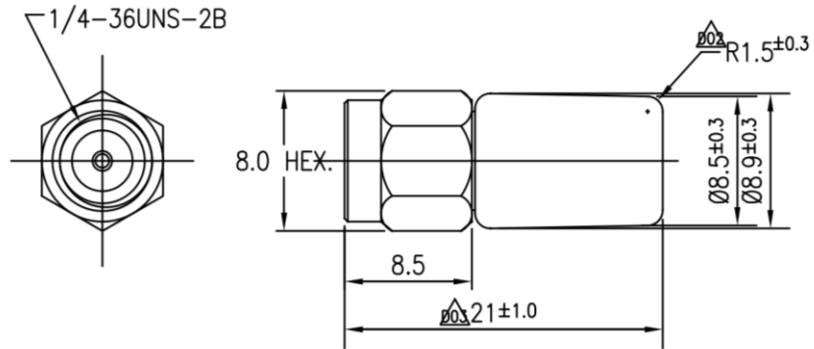

6. Packaging

140pcs GW.23.A151 per Tray
Weight: 0.52Kg

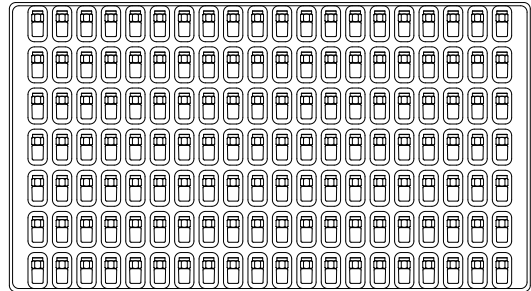

8 Trays per Set
1120 pcs per Set
Weight: 4.2Kg

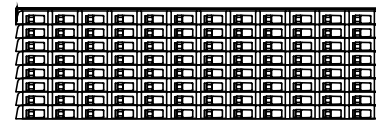
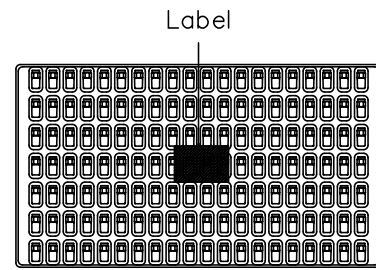

1120pcs per Carton
Dimensions: 425 x 240 x 130mm
Weight: 4.65Kg

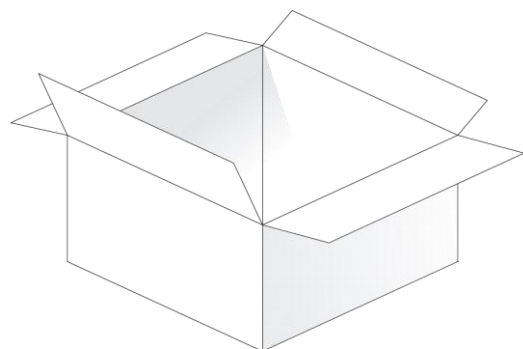

Changelog for the datasheet

SPE-24-8-013 – GW.23.A151

Revision: A (First Release)	
Date:	2024-01-19
Notes:	
Author:	Cesar Sousa

Previous Revisions

Revision:	
Date:	
Notes:	
Author:	

Revision:	
Date:	
Notes:	
Author:	

Revision:	
Date:	
Notes:	
Author:	

Revision:	
Date:	
Notes:	
Author:	

Revision:	
Date:	
Notes:	
Author:	



www.taoglas.com

