



# TAOGLAS®



# Datasheet

## GNSS Dual Feed Stacked Patch

**Part No:**  
HP54510A

### Description

Passive Multiband High Precision GNSS L1/L5 Stacked Patch Antenna

### Features:

Bands Covered:

- BeiDou (B1/B2a)
- GPS/QZSS (L1/L5)
- GLONASS (G1)
- Galileo (E1/E5a)
- L Band Corrections

Dual pin, dual feed, 4-pin configuration

Dimensions: 45 x 45 x 10mm

RoHS & Reach Compliant

<b>1.</b>	<b>Introduction</b>	<b>3</b>
<b>2.</b>	<b>Specification</b>	<b>4</b>
<b>3.</b>	<b>Antenna Characteristics</b>	<b>6</b>
<b>4.</b>	<b>Radiation Patterns</b>	<b>10</b>
<b>5.</b>	<b>Mechanical Drawing</b>	<b>16</b>
<b>6.</b>	<b>Antenna Integration</b>	<b>17</b>
<b>7.</b>	<b>Packaging</b>	<b>25</b>
<hr/>		
	Changelog	26

Taoglas makes no warranties based on the accuracy or completeness of the contents of this document and reserves the right to make changes to specifications and product descriptions at any time without notice. Taoglas reserves all rights to this document and the information contained herein. Reproduction, use or disclosure to third parties without express permission is strictly prohibited.



# 1. Introduction



The Taoglas HP54510A is a high performance, multi-band passive GNSS antenna that has been carefully designed to provide fantastic positional accuracy on the L1/L5 GNSS spectrum. It covers GPS/QZSS L1/L5, GLONASS G1, Galileo E1/E5a, BeiDou B1/B2a, as well as SBAS (WAAS/EGNOS/GAGAN/SDCM/SNAS) as well as the L Band at 1525MHz.

Correct implementation of the HP54510A allows the user to achieve higher location accuracy, as well as stability of position tracking in urban environments. The stacked patch construction has excellent performance across the full bandwidth of the antenna.

Its design has an even gain across the hemisphere, giving excellent axial ratio, which in turn makes it extremely resilient to multipath rejection and provides excellent phase center stability to ensure a location is correctly established in a navigation system.

Typical applications that benefit from high precision capabilities include:

- Autonomous Driving
- Precision Agriculture
- Telematics & Container / Asset Tracking
- Timing Accuracy Synchronization
- Precision Positioning for Robotics

The HP54510A is the latest embedded addition to Taoglas' product portfolio of high precision GNSS antennas. When used on the base and/or the rover as part of an RTK configuration, the HP54510A can achieve genuine cm-level accuracy with proven results.

Full integration guidelines are contained in Section 6 of this datasheet including the Taoglas [HC125A](#) hybrid coupler that will be required for use for dual pin feed patch integrations.

Contact your regional Taoglas Customer Services team for more information on any of the products listed above or for support regarding integration.

## 2. Specification

GNSS Frequency Bands					
GPS	L1 1575.42 MHz	L2 1227.6 MHz	L5 1176.45 MHz		
	■	□	■		
GLONASS	G1 1602 MHz	G2 1248 MHz	G3 1207 MHz		
	■	□	□		
Galileo	E1 1575.24 MHz	E5a 1176.45 MHz	E5b 1201.5 MHz	E6 1278.75 MHz	
	■	■	□	□	
BeiDou	B1C 1575.42 MHz	B1I 1561 MHz	B2a 1176.45 MHz	B2b 1207.14 MHz	B3 1268.52 MHz
	■	■	□	□	□
L-Band	L-Band 1542 MHz				
	■				
QZSS (Regional)	L1 1575.42 MHz	L2C 1227.6 MHz	L5 1176.45 MHz	L6 1278.75e6	
	■	□	■	□	
IRNSS (Regional)	L5 1176.45 MHz				
	■				
SBAS	L1/E1/B1 1575.42 MHz	L5/B2a/E5a 1176.45 MHz	G1 1602 MHz	G2 1248 MHz	G3 1207 MHz
	■	■	■	□	□

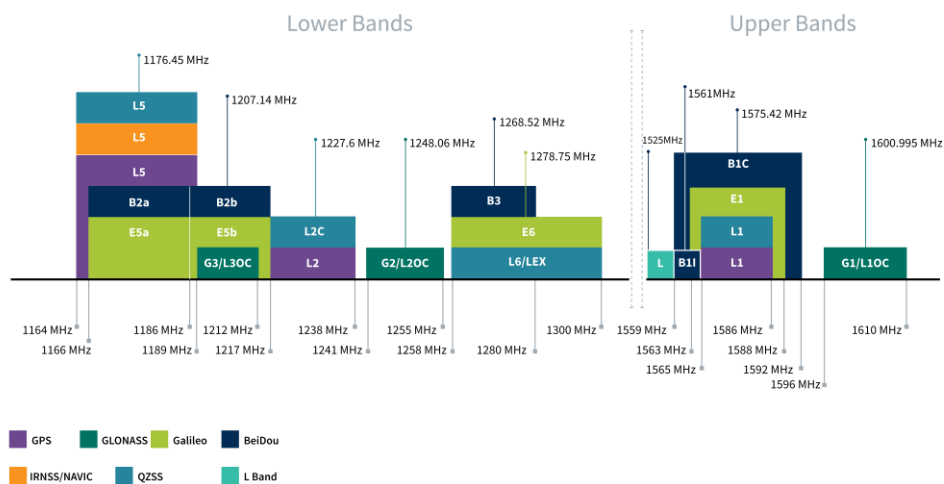

GNSS Bands and Constellations

Electrical					
Frequency (MHz)	GPS L5	L Band	BeiDou B1	GPS L1	GLONASS G1
	1166-1187	1525-1559	1559-1563	1563-1587	1593-1610
Efficiency (%)	82.7	71.5	83.5	83.5	61.1
Average Gain (dB)	-0.83	-1.46	-0.78	-0.78	-2.14
Peak Gain (dBi)	4.82	4.94	5.06	5.08	4.15
Axial Ratio(dB)	4.42	1.35	1.27	1.34	1.82
Impedance	50 $\Omega$				
Polarization	RHCP				
Radiation Pattern	Directional				

\*Antenna properties were measured with the antenna mounted on 70\*70mm Ground Plane with Hybrid Coupler

Mechanical	
Dimensions	45 x 45 x 10 mm
Weight	54g
Material	Ceramic
Environmental	
Operating Temperature	-40°C to 85°C
Storage Temperature	-40°C to 85°C
Humidity	Non-condensing 65°C 95% RH

### 3. Antenna Characteristics

#### 3.1 Test Setup

AUT



Vector Network Analyzer

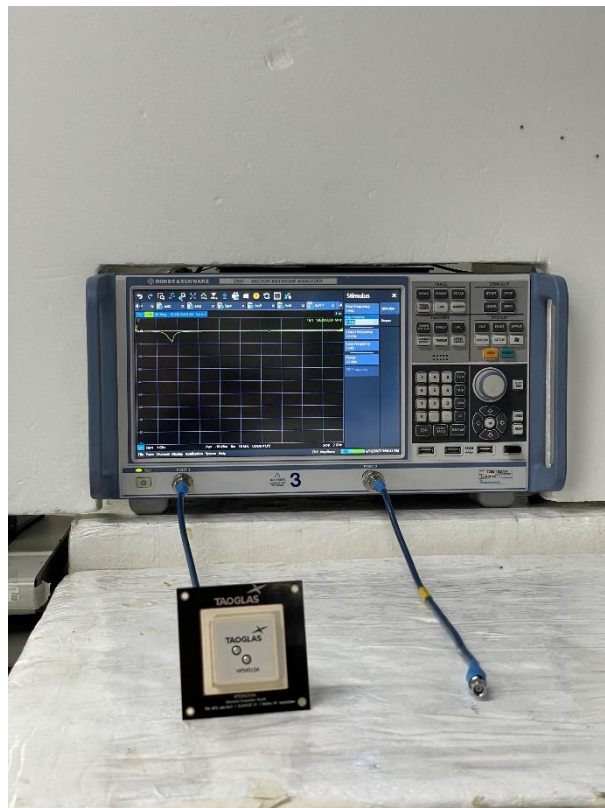

Tested on a 70x70mm Ground Plane

### 3.2 Return Loss

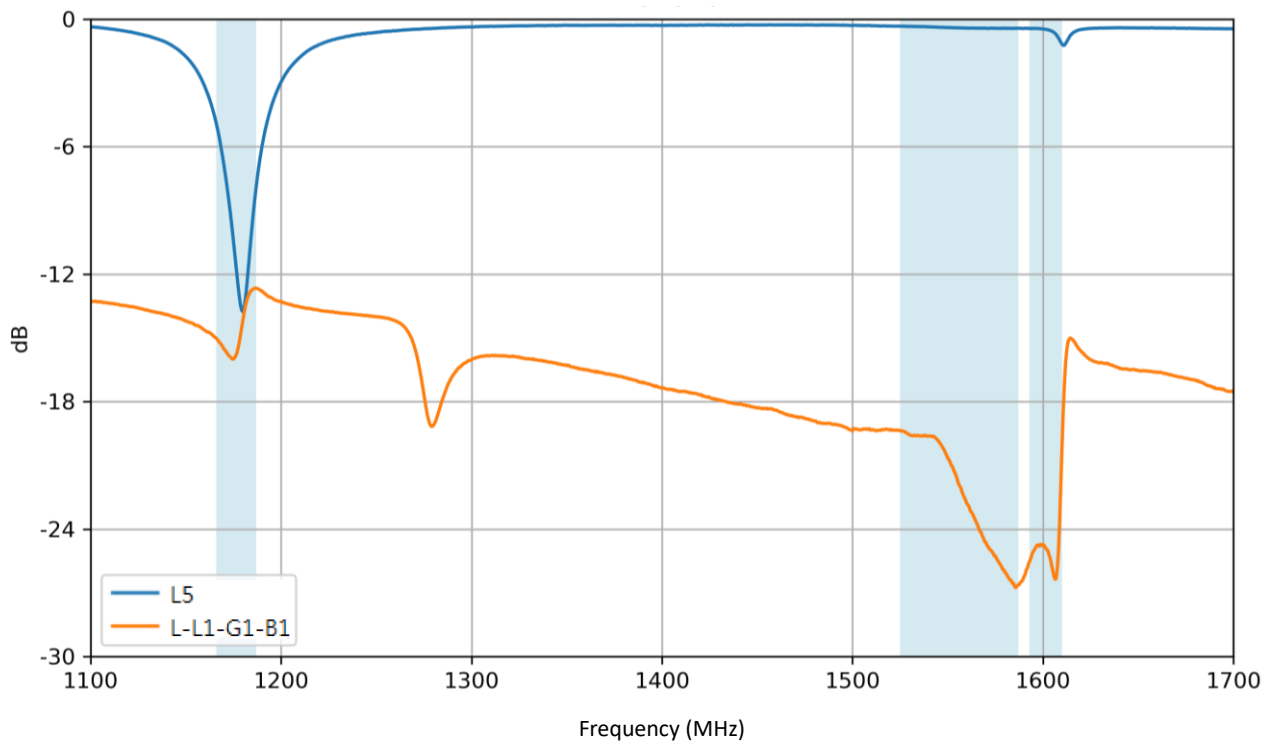

### 3.3 Efficiency

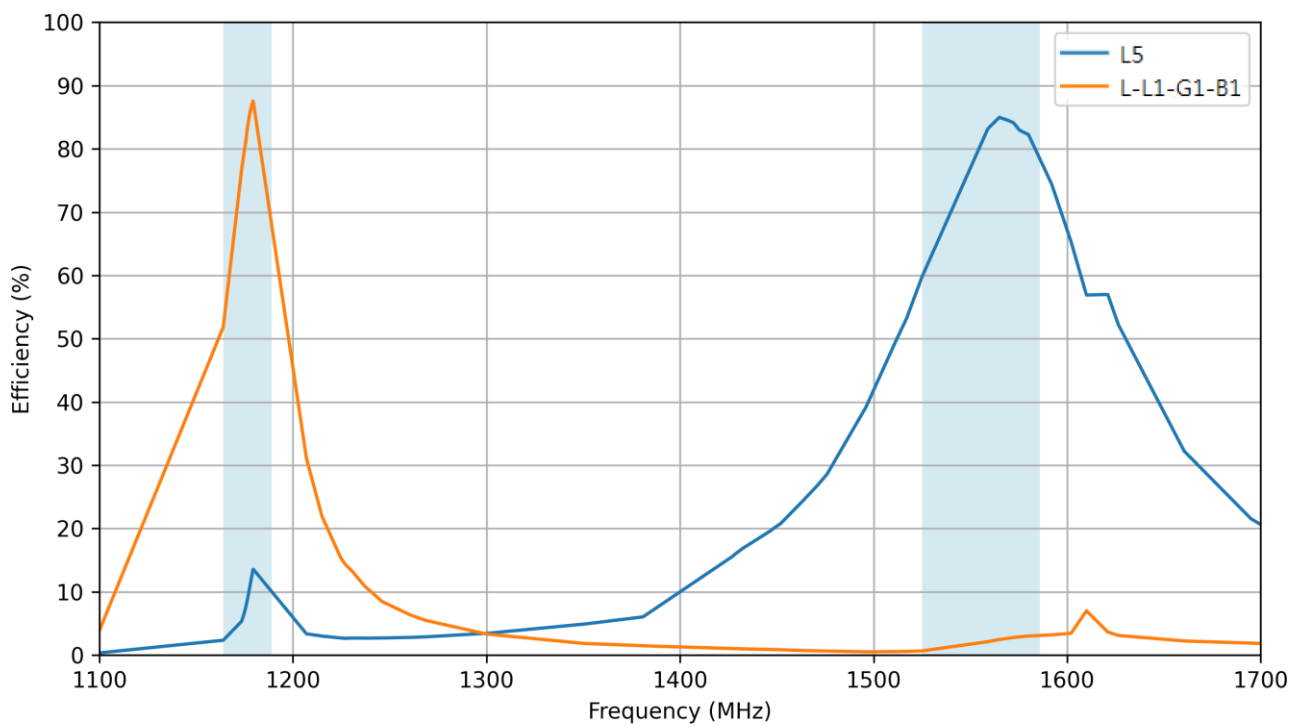

### 3.4 Average Gain

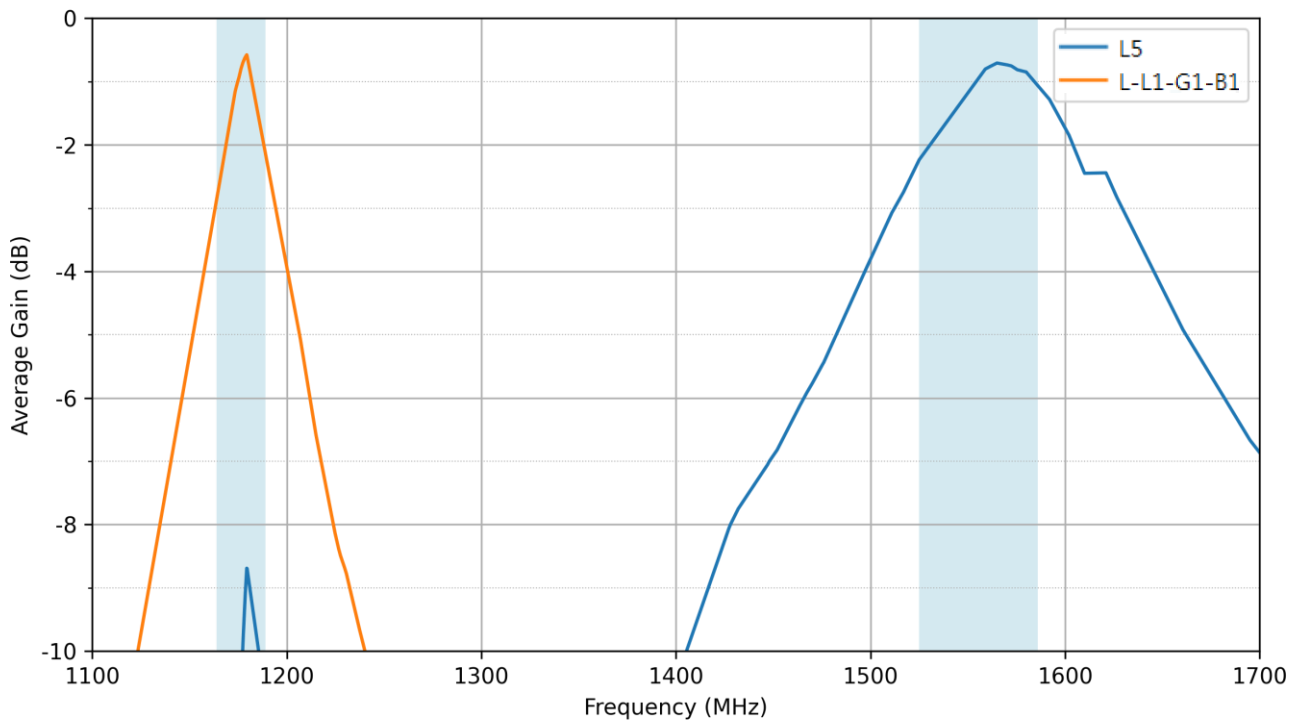

### 3.5 Peak Gain

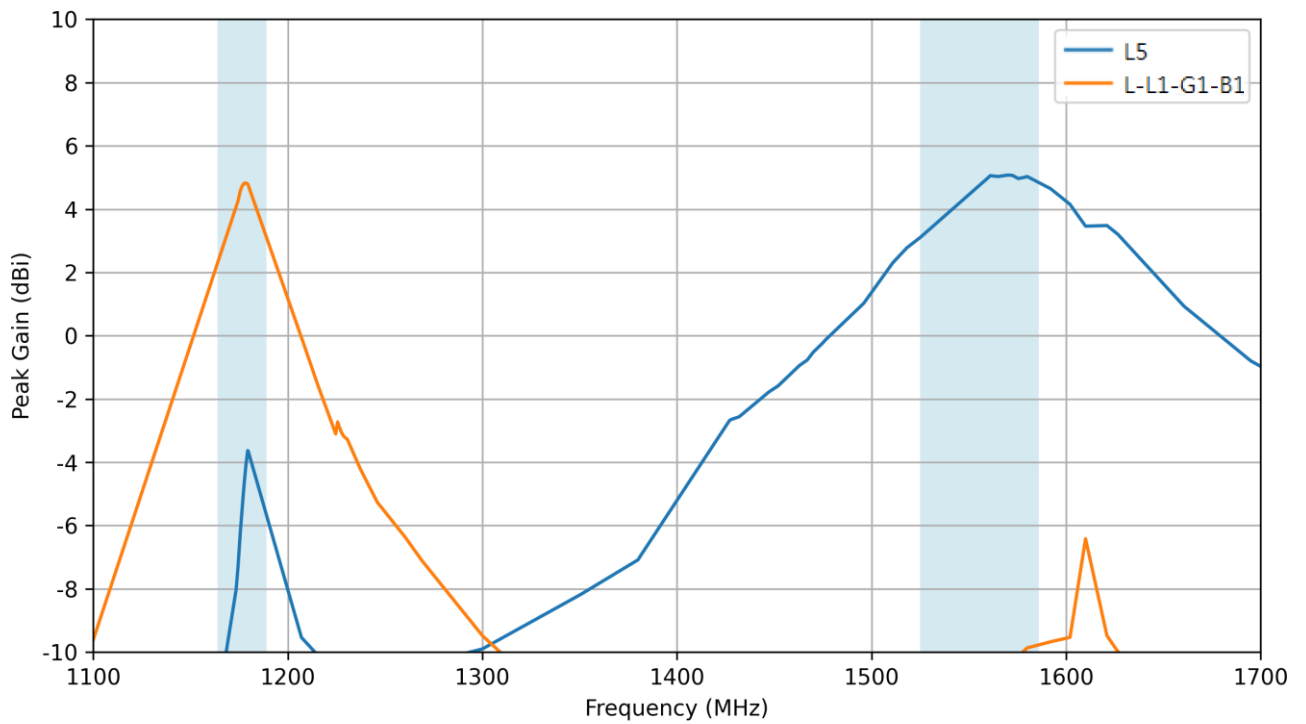



### 3.6 Axial Ratio

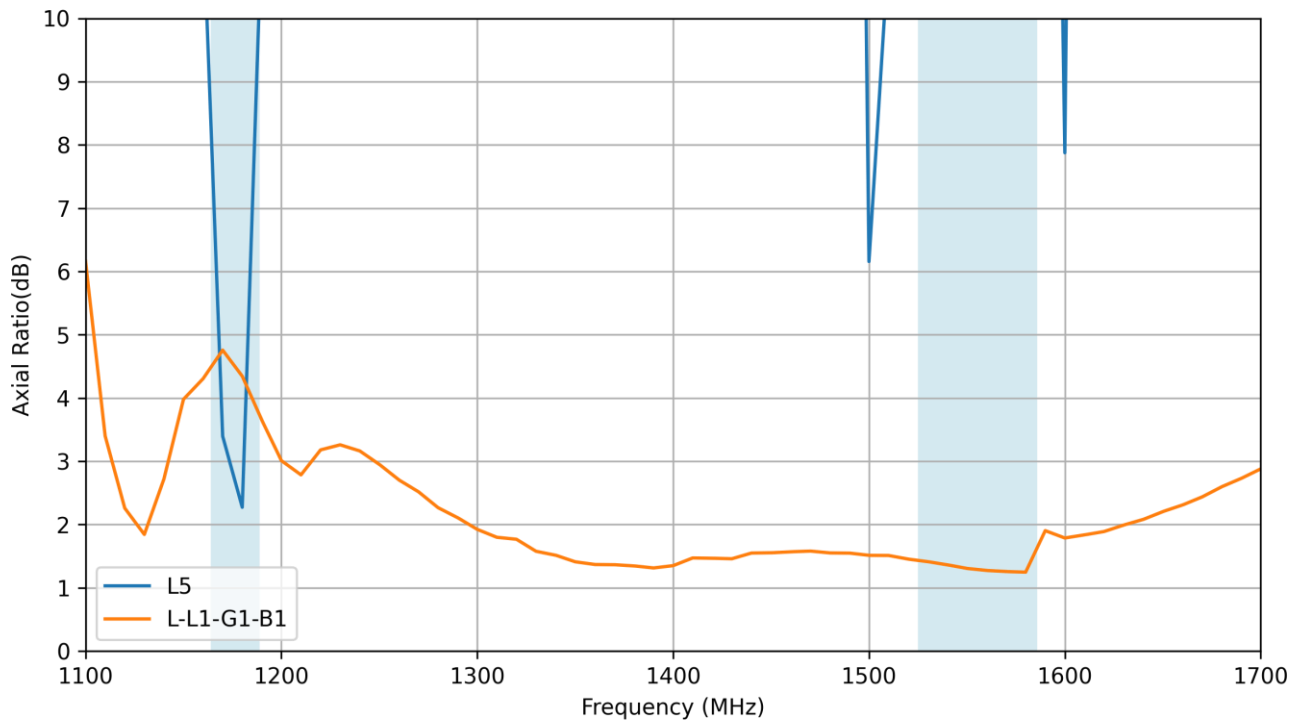

## 4. Radiation Patterns

### 4.1 Test Setup

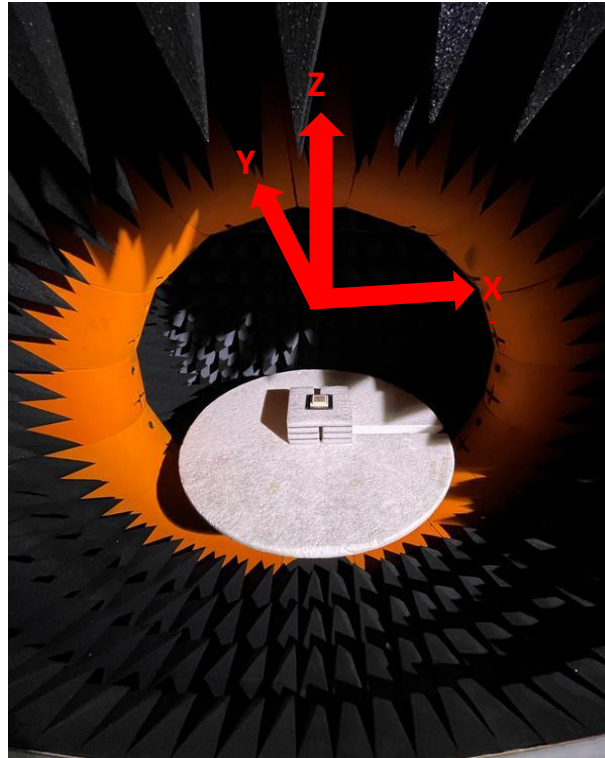

Tested on a 70x70mm Ground Plane

4.2 Patterns at 1176.45MHz

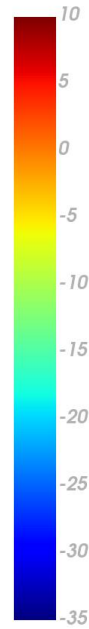
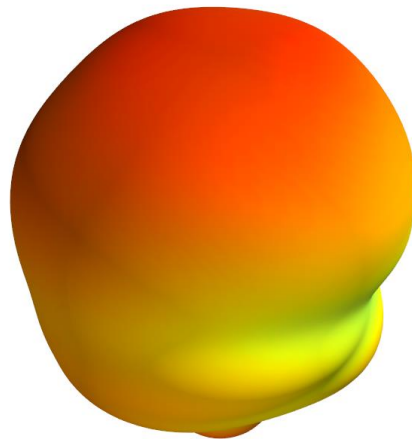

XZ Plane                      YZ Plane                      XY Plane

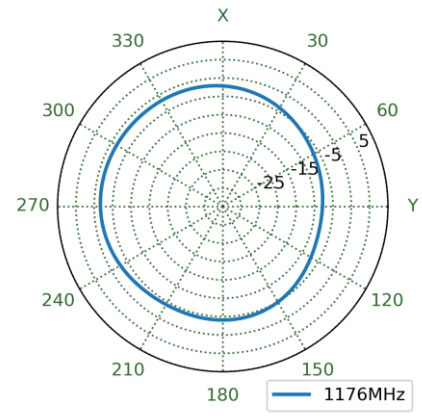
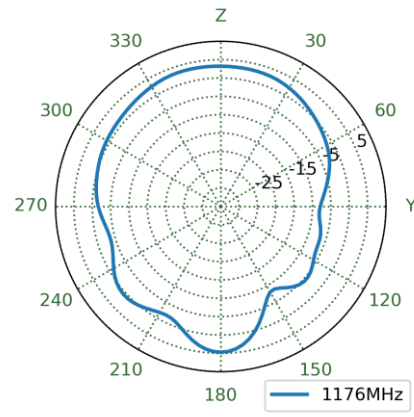
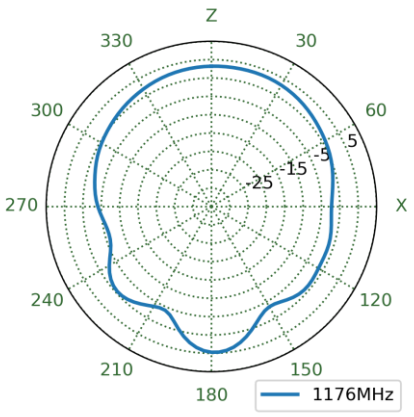

4.3 Patterns at 1525MHz

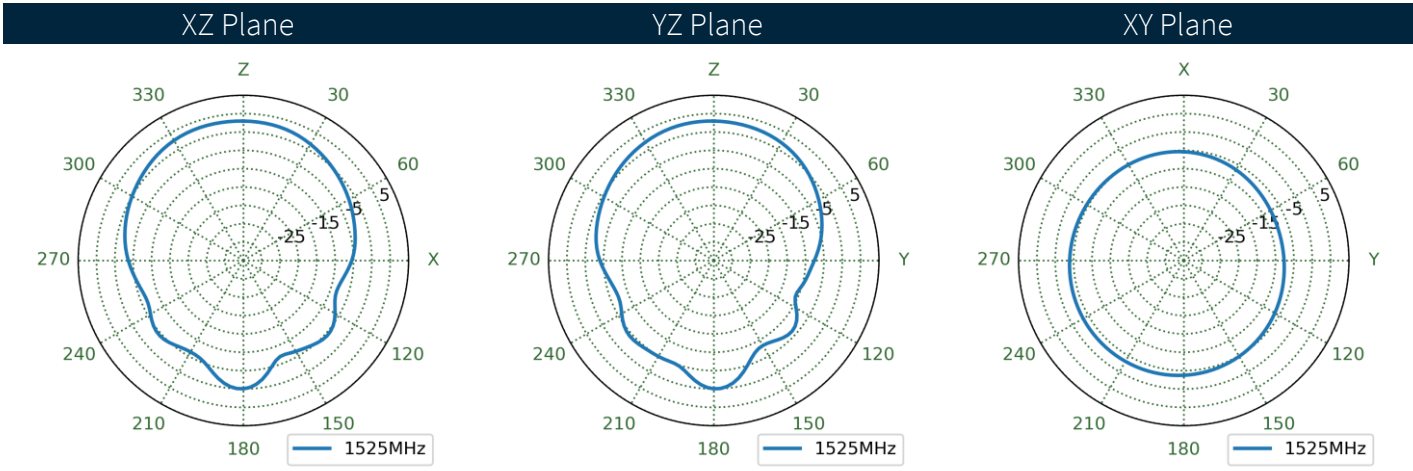
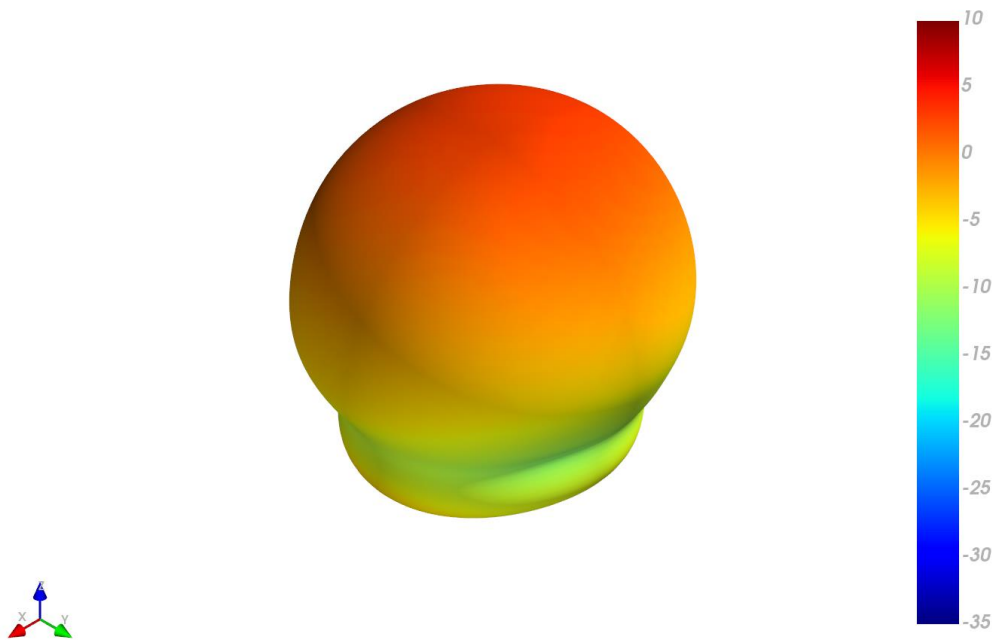

4.4 Patterns at 1561MHz

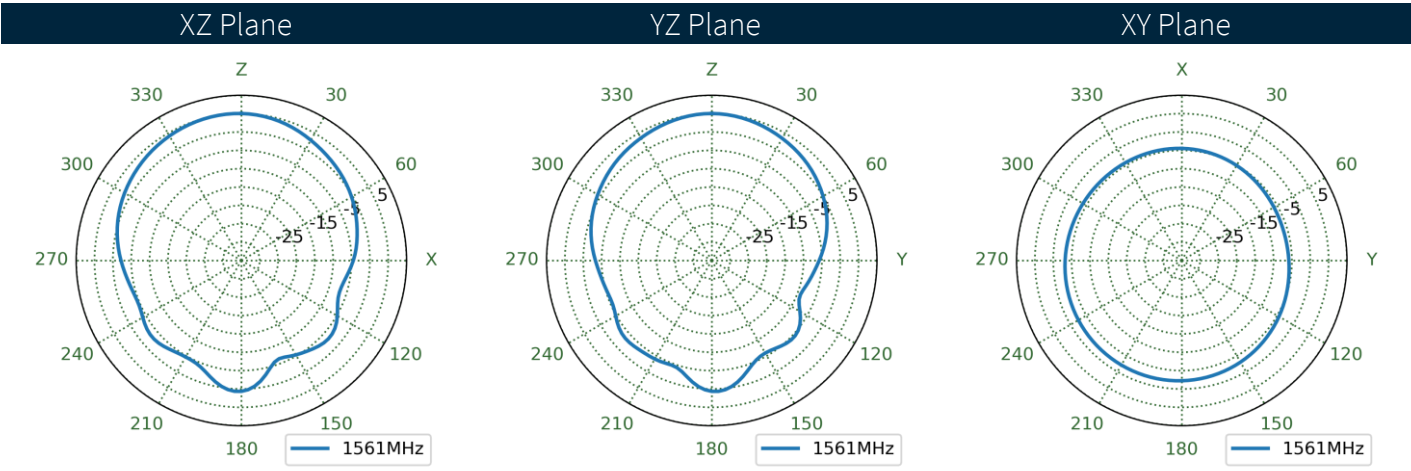
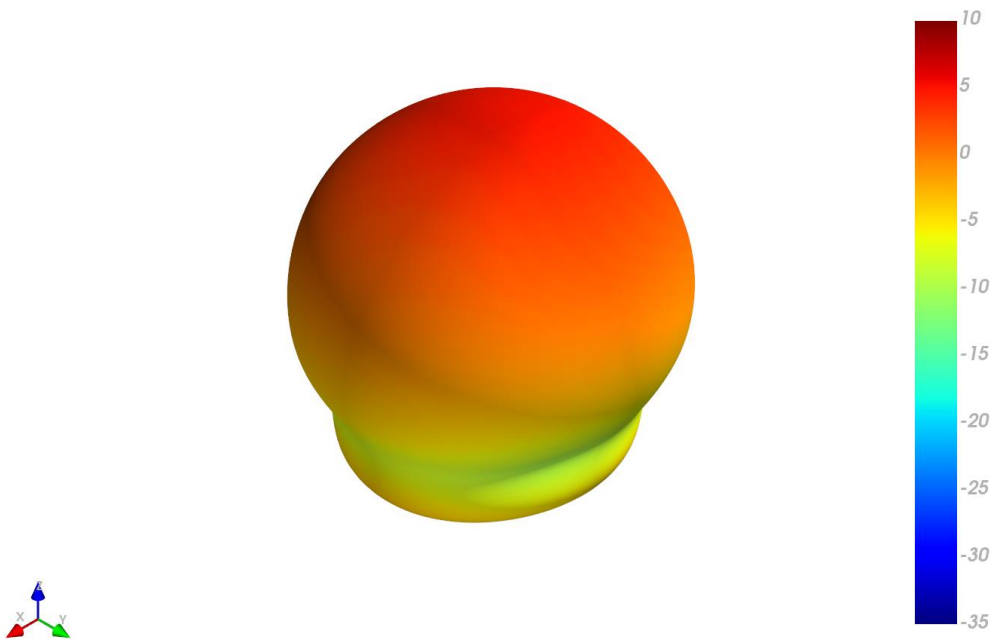

4.5 Patterns at 1575MHz

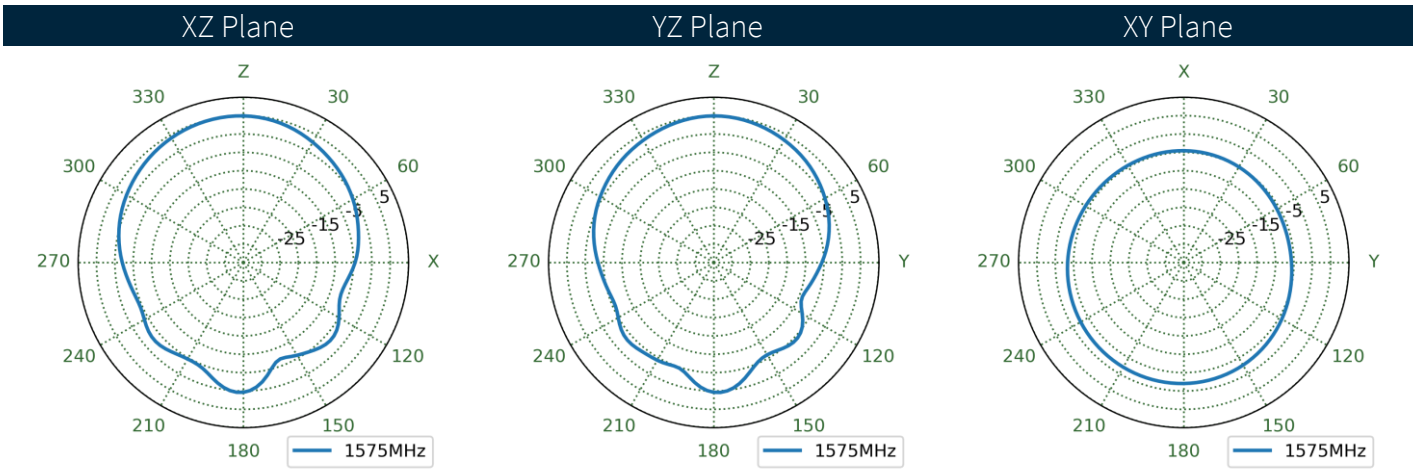
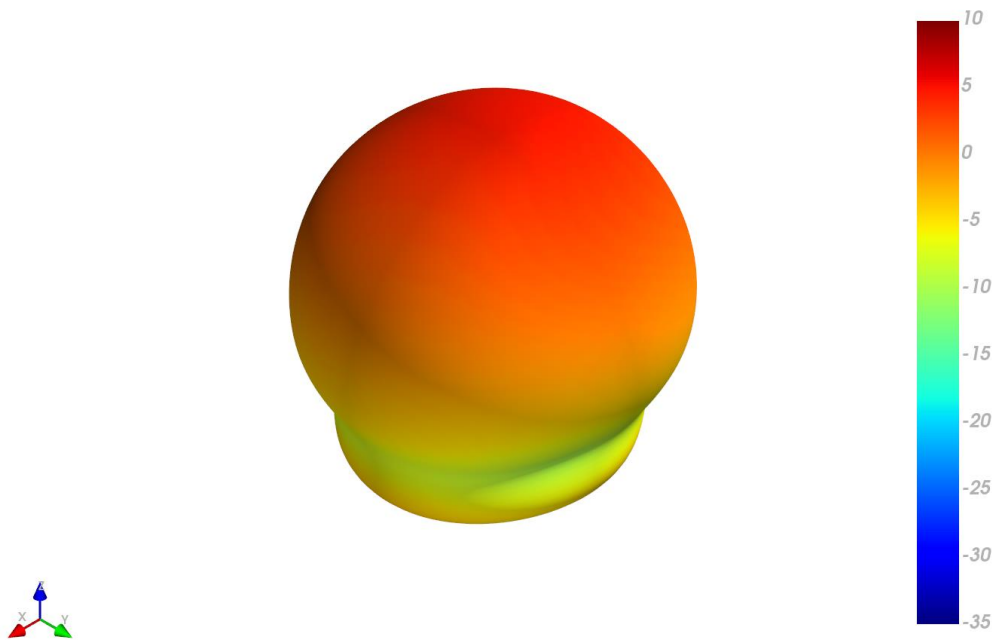

4.6 Patterns at 1602MHz

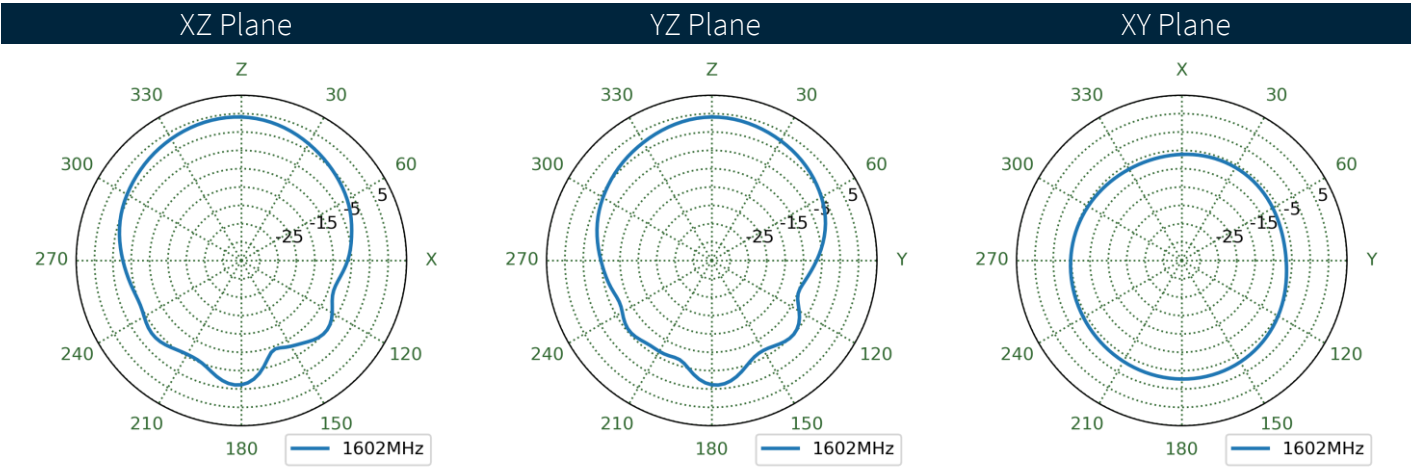
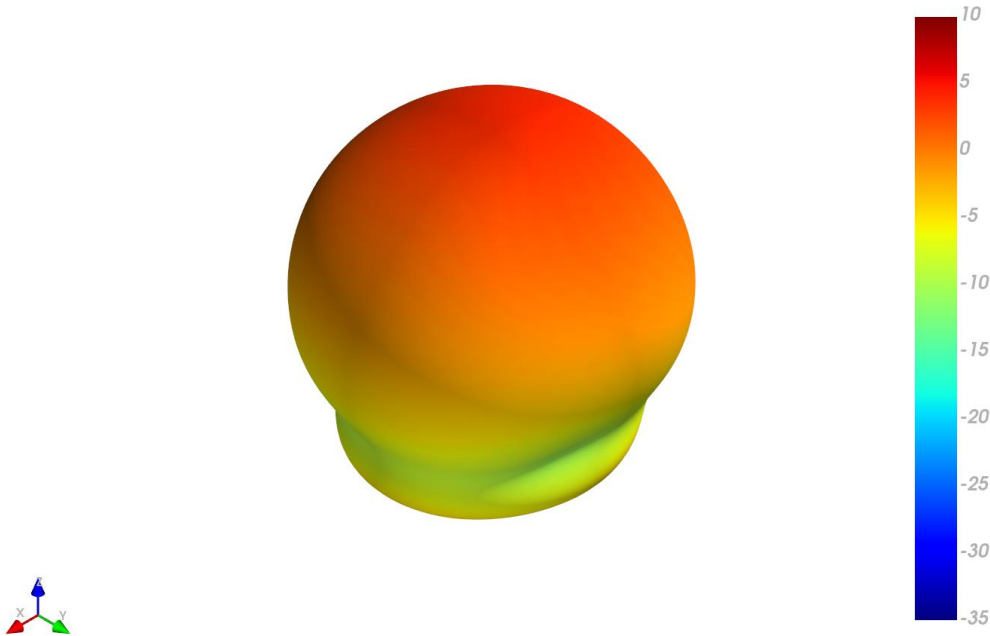

# 5. Mechanical Drawing

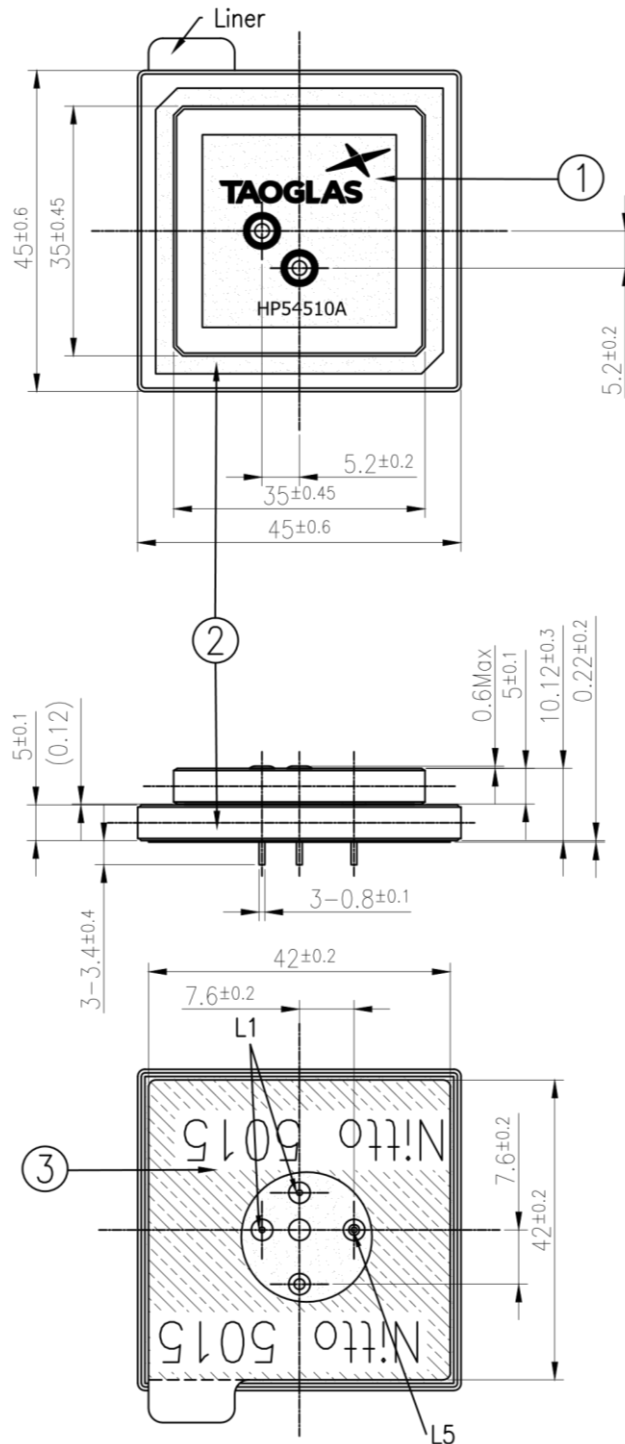

	Name	Material	Finish	QTY
1	Top Patch (35x35x5mm)	Ceramic	Clear	1
2	Bottom Patch (45x45x5mm)	Ceramic	Clear	1
3	Double sided Adhesive	NITTO 5015	White Liner	1



## 6. Antenna Integration

The following is an example on how to integrate the HP54510A into a design. This antenna has three pins, two pins are used for the L1 band, and the other pin is used for the L5 band. A Hybrid coupler ([HC125A](#)) is used to combine the feeds for the L1 band, to create a Right Hand Circular Polarized (RHCP) signal at the output of the hybrid coupler. Taoglas recommends using a minimum of 70x70mm ground plane (PCB) to ensure optimal performance before being presented to the GNSS Module. Taoglas recommends our [TFM.100B](#), a high-performance GNSS Module specifically engineered for use with our multi feed patches.

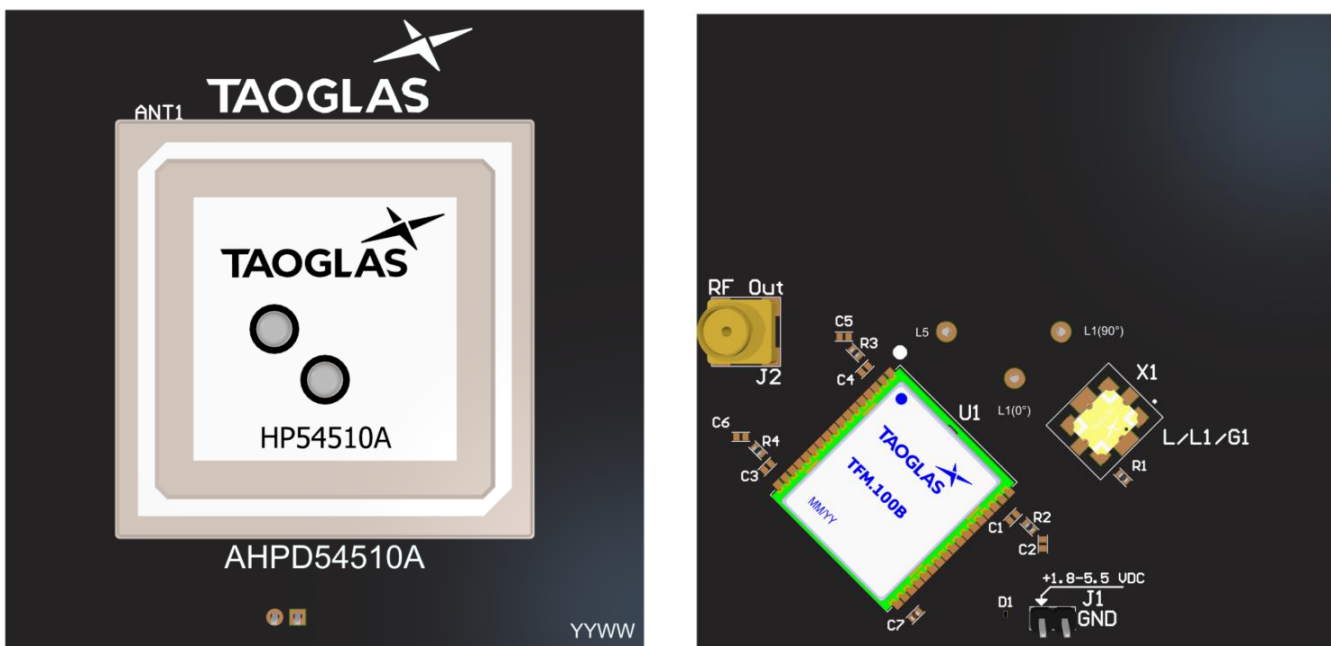

Top and bottom view of PCB.

Please find the Integration files in Altium, 2D formats and the 3D model for the HP54510A here: <https://www.taoglas.com/product/hp5410a-gnss-l1-l5-stacked-patch-antenna/>

## 6.1 Schematic Symbol and Pin Definition

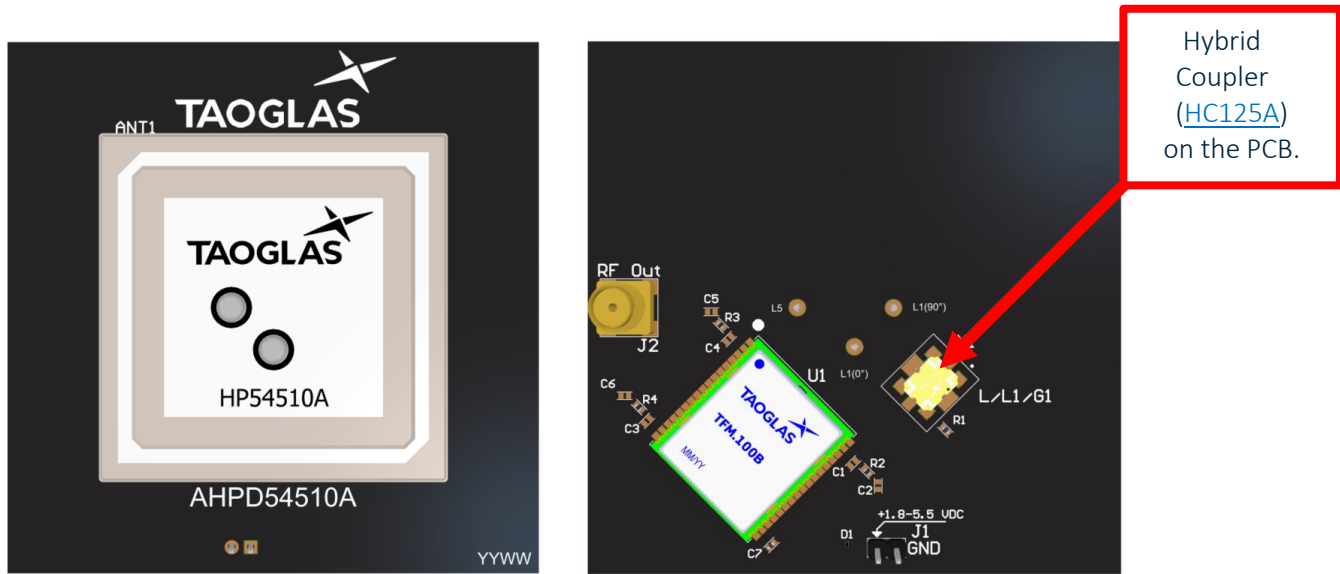

Above are the 3D models of the HP54510A and [HC125A](#) on the PCB.

The circuit symbol for the HP54510A is shown below. The antenna has 3 pins as indicated below.

Pin	Description
1	L1 (0°)
2	L1 (-90°)
3	L5

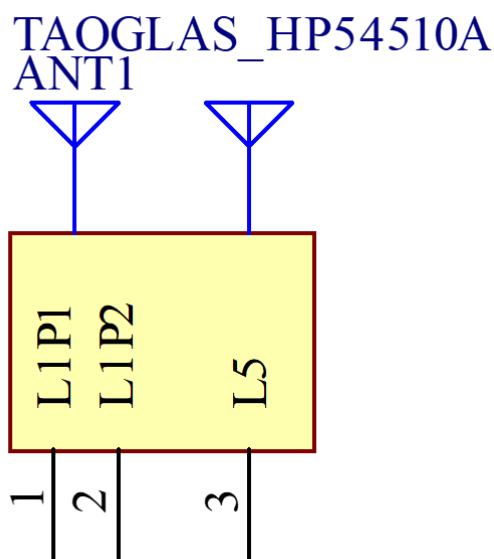

Above is a schematic symbol of HP54510A and a table of the pin definitions.

## 6.2 Schematic Layout

The L1 band of the HP54510A uses two orthogonal feeds that need to be combined in a hybrid coupler to ensure optimal axial ratio and RHCP Gain is achieved. Taoglas recommends our [HC125A](#), a high-performance hybrid coupler specifically engineered for use with our multi feed patches.

The [HC125A](#) is required for the high GNSS band of operation (1559- 1610MHz) for this antenna. This hybrid coupler should be placed close to the antenna pins and terminated correctly using a 49.9 Ohm resistor.

Designator	Type	Value	Manufacturer	Manufacturer Part Number
R1	Resistor	49.9 Ohms	Panasonic	ERJ-2RKF49R9X

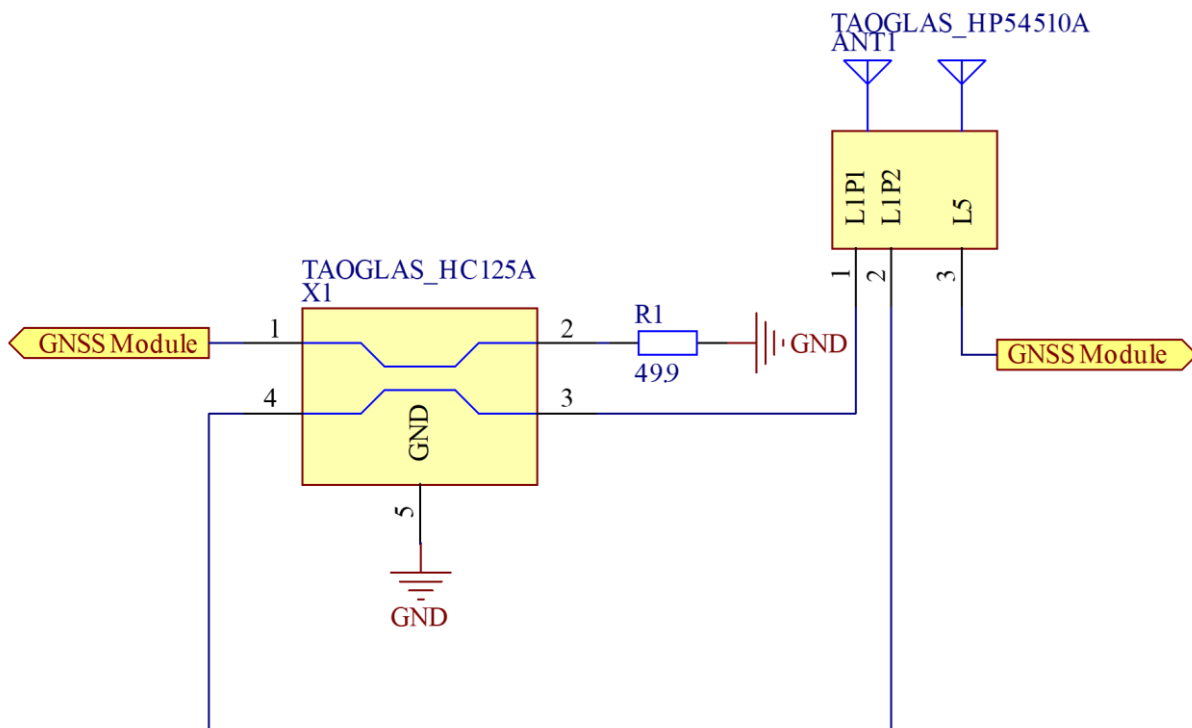

## 6.3 Antenna Footprint

IDW-XX-8-XXXX  
RELEASE

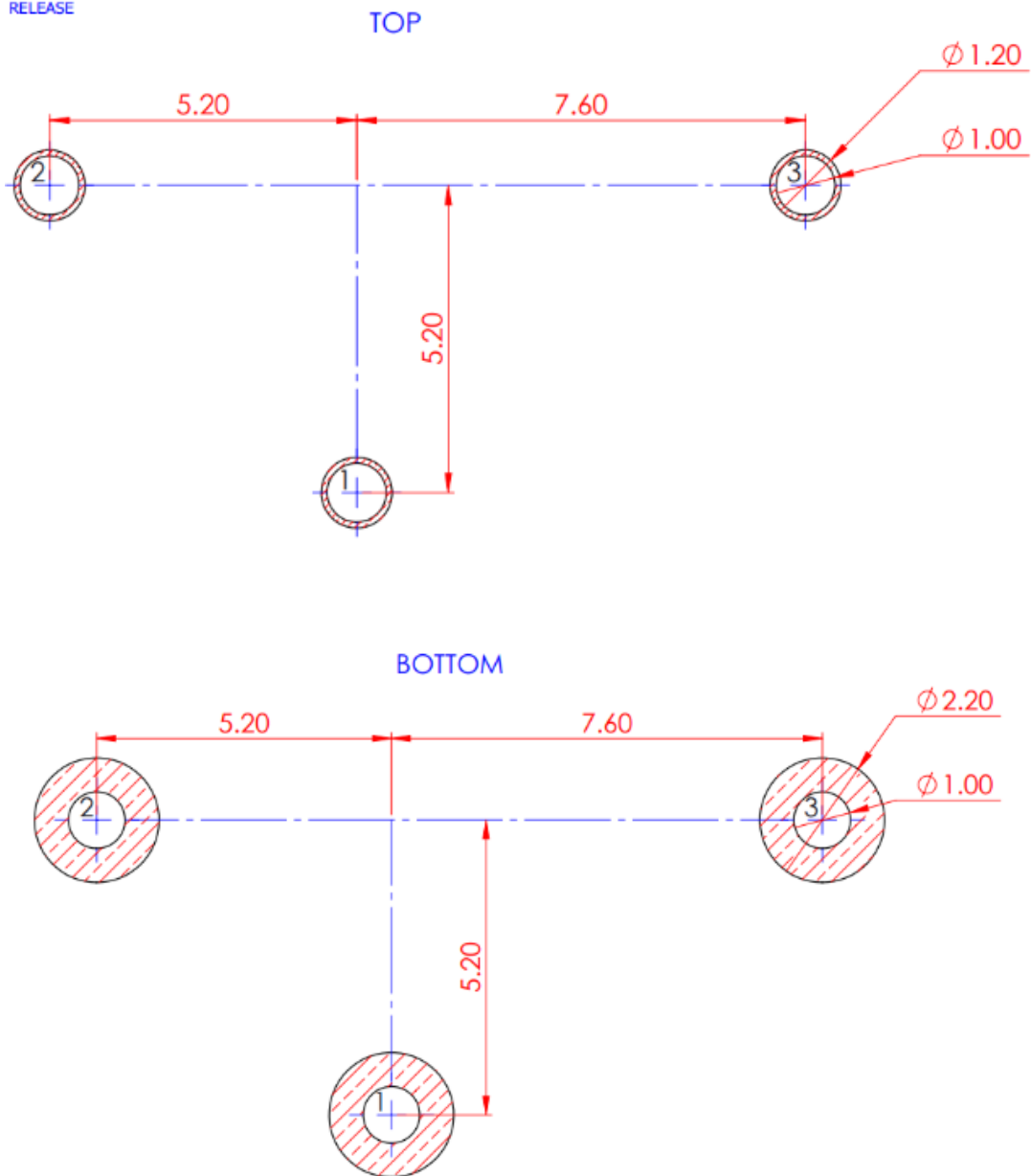

Pin	Description
1	L1 (0°)
2	L1 (-90°)
3	L5

## 6.4 Copper Clearance for HP54510A

The footprint and clearance on the PCB must comply with the antenna's specification. The PCB layout shown in the diagrams below demonstrates the HP54510A clearance area for Pin 1 (L1P1(0°) Pad), Pin 2 (L1P2(-90°) Pad) and Pin 3 (L5 Pad). The bottom copper keep out area only applies to the bottom layer and the top copper keep out area applies to all other layers.

There should be a  $\varnothing 3\text{mm}$  copper clearance around the antenna pins on the top side of the PCB with a  $\varnothing 3.5\text{mm}$  copper clearance around the antenna pins on the bottom side.

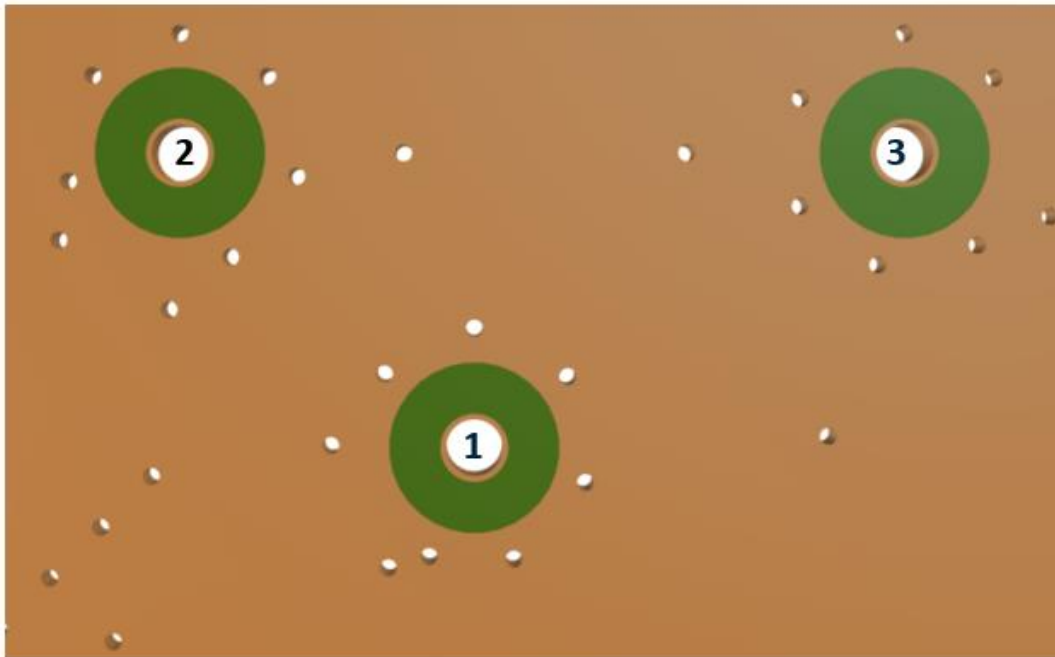

Top Side



Bottom Side

3D Images of Copper Clearances for HP54510A.

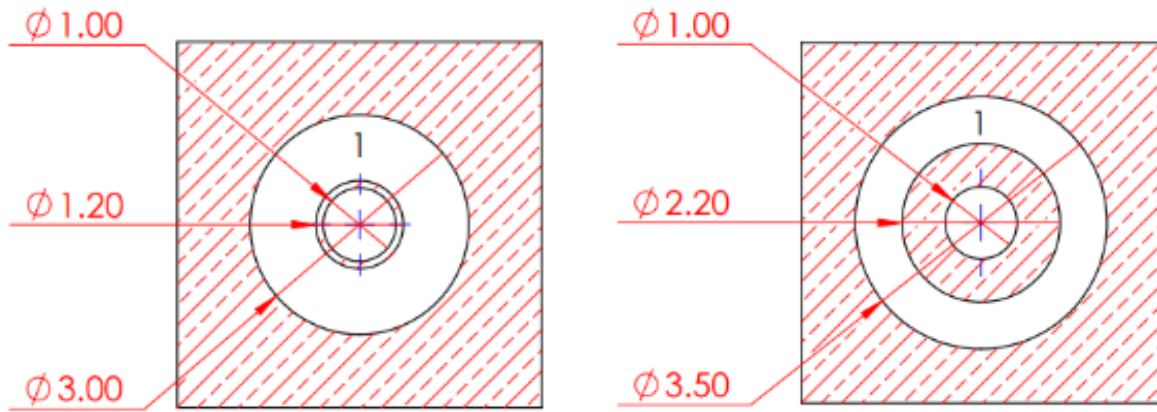

Copper Clearances for Pin 1 (L1P1(0°) Pad) of the HP54510A.

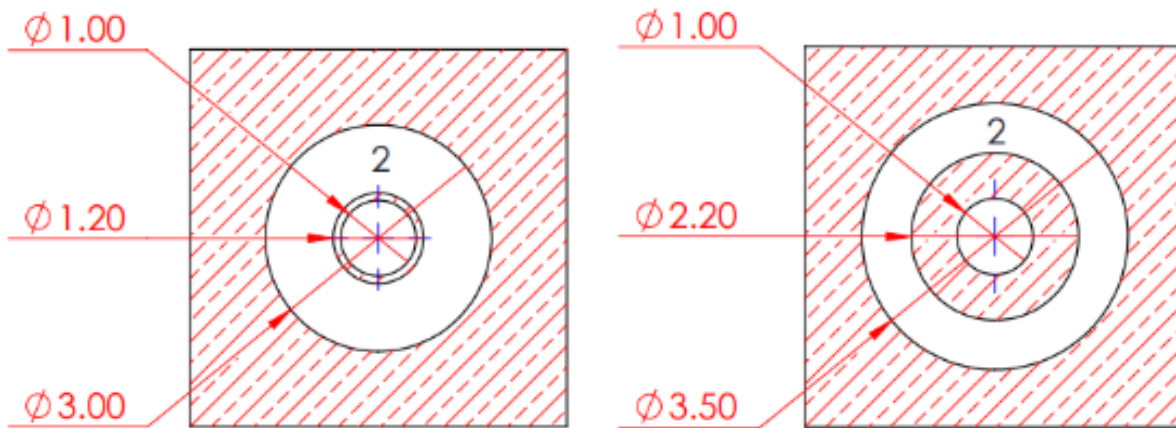

Copper Clearances for Pin 2 (L1P2(-90°) Pad) of the HP54510A.

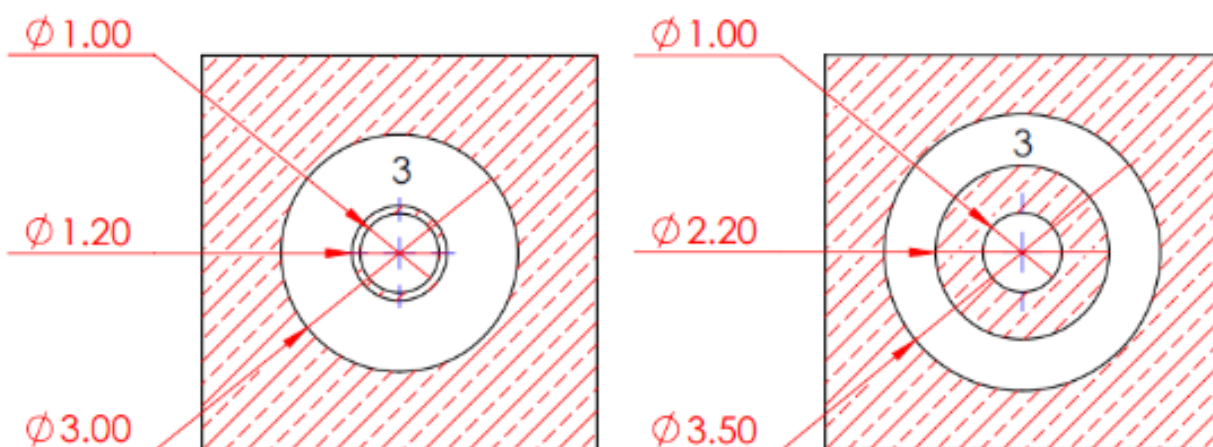

Copper Clearances for Pin 3 (L5 Pad) of the HP54510A.

## 6.5 Antenna Integration

The HP54510A should be placed in the center of the PCB to take advantage of the ground plane.

The RF trace must maintain a 50 Ohm transmission line. A “Pi” Matching Network is recommended for the RF transmission lines, the values and components for the matching circuit will depend on the tuning needed. Ground vias should be placed around the copper clearance area.

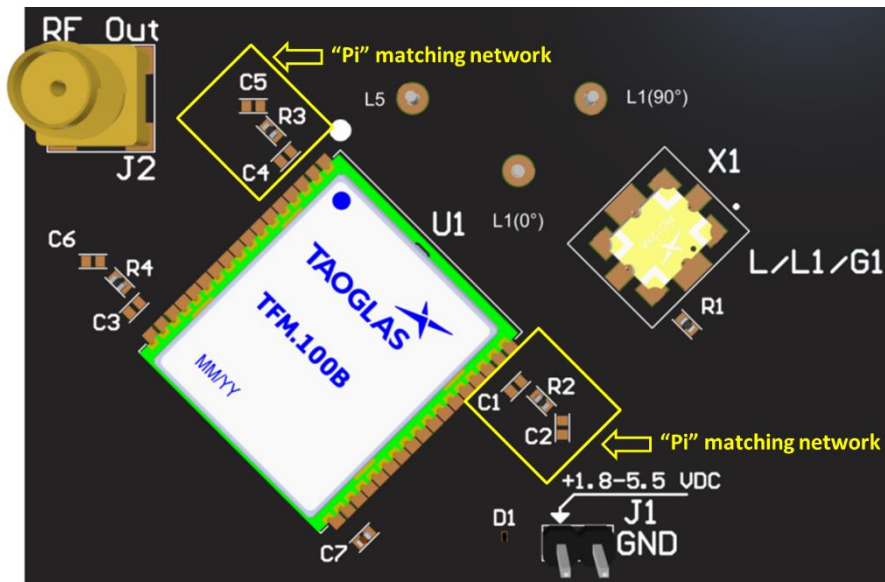

Bottom view of the PCB, showing “Pi” matching network.

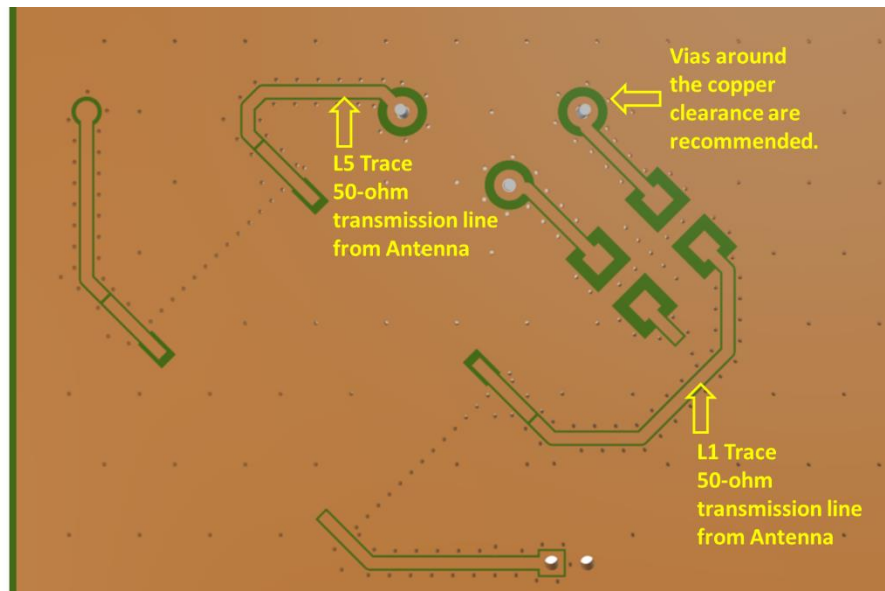

Bottom view of the PCB, showing transmission lines and integration notes.

## 6.6 Final Integration

The bottom side image shown below highlights the antenna connection to the hybrid coupler ([HC125A](#)). It shows the 49.9 Ohm terminating resistor necessary for the hybrid coupler ([HC125A](#)). Taoglas recommends using a minimum of 70x70mm ground plane (PCB) to ensure optimal performance.

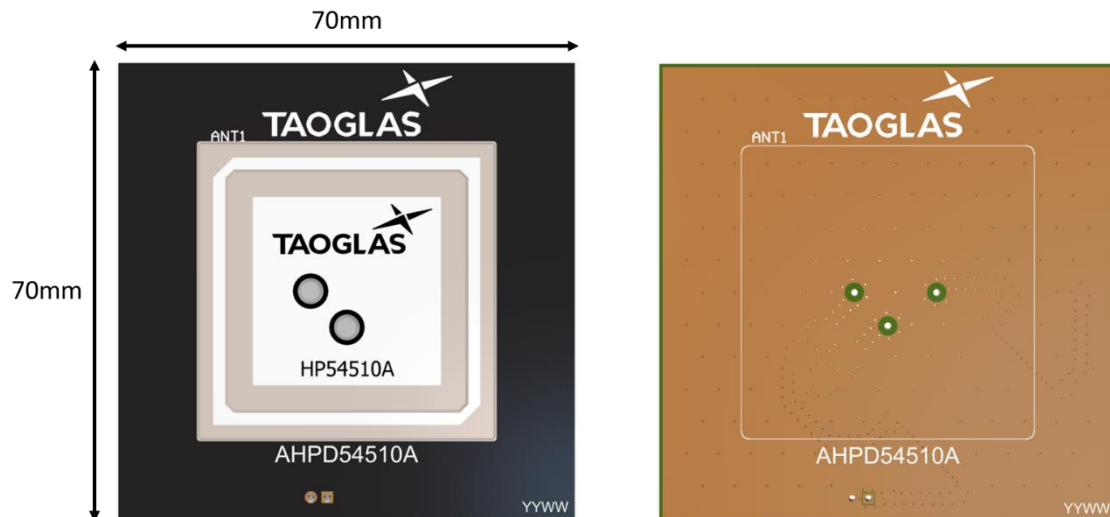

Top Side (HP54510A placement on 70x70mm PCB)

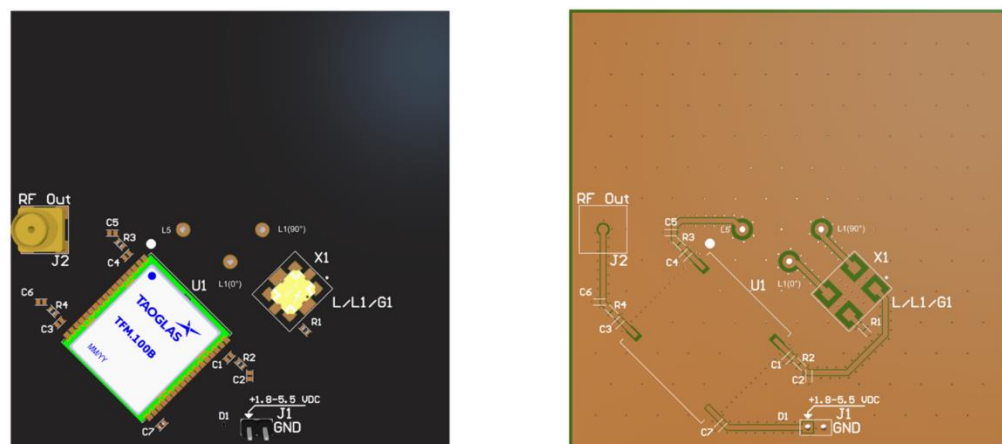

Bottom side ([TFM.100B](#) placement including [HC125A](#))



## 7. Packaging

8pcs HP54510 per Tray  
32pcs / Vacuum package

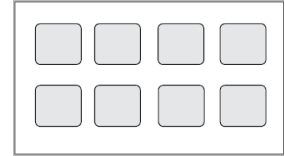

32pcs HP54510 per Small Box  
Dimensions - 236\*154\*96mm

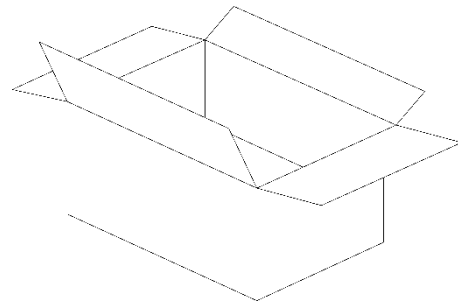

128pcs HP54510 per Carton  
Dimensions - 370\*370\*300mm

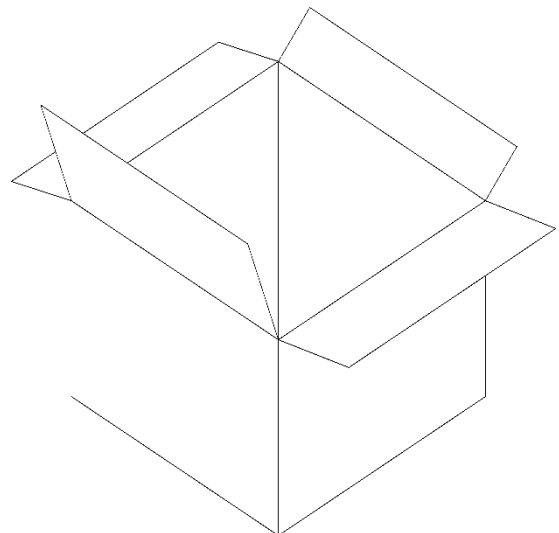

Changelog for the datasheet

**SPE-23-8-224– HP54510A**

**Revision: B (Current Release)**

Date:	2023-12-12
Notes:	Updated graphs and antenna integration guide.
Author:	Gary West

**Previous Revisions**

**Revision: A (Original First Release)**

Date:	2023-07-14
Notes:	Initial Release
Author:	Cesar Sousa



[www.taoglas.com](http://www.taoglas.com)

