



# TAOGLAS®



# Datasheet

## Comet Series

**Part No:**  
MA321.A.001

### Description

Comet 3-in-1GNSS and 2\*5G/4G MIMO Adhesive/Magnetic Mount Puck Antenna

### Features:

- Low-profile Housing with Adhesive/Magnetic Mount
- 1\*GNSS L1 Band
- 2\* 5G/4G MIMO 600-6000MHz
- Worldwide 5G Bands including legacy 4G 3G and 2G bands
- IP67 Waterproof Enclosure
- Dimensions: Diameter 80mm \* 18.1mm
- 2m Low Loss TGC-1.5DS cable with SMA(M) connectors
- Custom Cables and Connectors Available
- RoHS & Reach Compliant

<b>1.</b>	<b>Introduction</b>	<b>2</b>
<b>2.</b>	<b>Specification</b>	<b>3</b>
<b>3.</b>	<b>Antenna Characteristics</b>	<b>7</b>
<b>4.</b>	<b>Radiation Patterns</b>	<b>17</b>
<b>5.</b>	<b>Mechanical Drawing</b>	<b>71</b>
<b>6.</b>	<b>Packaging</b>	<b>72</b>
<b>7.</b>	<b>Application Note</b>	<b>73</b>
<hr/>		
	Changelog	82

Taoglas makes no warranties based on the accuracy or completeness of the contents of this document and reserves the right to make changes to specifications and product descriptions at any time without notice. Taoglas reserves all rights to this document and the information contained herein. Reproduction, use or disclosure to third parties without express permission is strictly prohibited.



# 1. Introduction



The Taoglas Comet MA321 is a low profile, puck style, adhesive or magnetic mount antenna. The MA321 contains two 5G/4G high-performance antennas for use in MIMO cellular systems and one GNSS antenna. Through innovative antenna engineering techniques, it covers all worldwide cellular frequencies from 600MHz to 6GHz and GNSS Bands, BeiDou, GPS and GLONASS with stable gain and high efficiency, usually difficult to achieve in smaller style antennas.

The Comet series has been designed to be compact and low profile, measuring just 80x18mm, to be utilized in application areas where other larger and taller antennas are not possible. The robust ASA magnetic mount enclosure is designed to be waterproof rated to IP67 and can be mounted internally or externally on devices or vehicles.

Typical Applications Include:

- Telematics, Transport and Fleet Management
- Gateways and Routers
- Digital Signage and Point of Sale Terminals
- First Responder and Emergency Services

The Comet has been designed with an option for either magnetic or adhesive mounting. This allows it to be utilized and installed in applications where destructive installations are not allowed, such as drilling mounting holes to secure a permanent antenna on a leased vehicle. The Comet is supplied with an additional 3M foam high-performance pad for adhesive mount application.

The GNSS and cellular MIMO connections utilize 2m of TGC-1.5DS coaxial cable with SMA(M) connectors as standard. Customized cable and connector versions are also available upon request. Contact your regional Taoglas customer support team for further information.

## 2. Specification

GNSS Frequency Bands					
GPS	L1 1575.42 MHz	L2 1227.6 MHz	L5 1176.45 MHz		
	■	□	□		
GLONASS	G1 1602 MHz	G2 1248 MHz	G3 1207 MHz		
	■	□	□		
Galileo	E1 1575.24 MHz	E5a 1176.45 MHz	E5b 1201.5 MHz	E6 1278.75 MHz	
	■	□	□	□	
BeiDou	B1C 1575.42 MHz	B1I 1561 MHz	B2a 1176.45 MHz	B2b 1207.14 MHz	B3 1268.52 MHz
	■	■	□	□	□
L-Band	L-Band 1542 MHz				
	□				
QZSS (Regional)	L1 1575.42 MHz	L2C 1227.6 MHz	L5 1176.45 MHz	L6 1278.75e6	
	■	□	□	□	
IRNSS (Regional)	L5 1176.45 MHz				
	□				
SBAS	L1/E1/B1 1575.42 MHz	L5/B2a/E5a 1176.45 MHz	G1 1602 MHz	G2 1248 MHz	G3 1207 MHz
	■	□	■	□	□

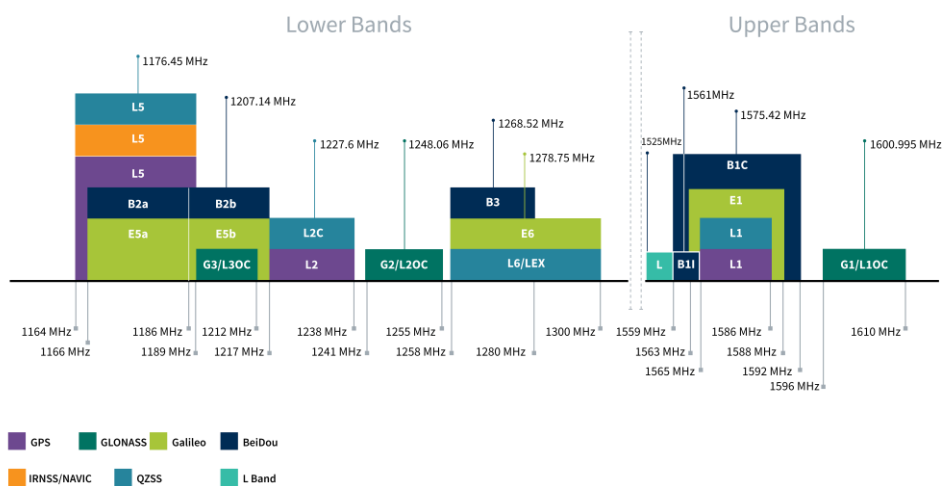

GNSS Bands and Constellations

GNSS Electrical								
Band	Frequency (MHz)	Measurement	Efficiency (%)	Average Gain (dB)	Peak Gain (dBi)	Impedance	Polarization	Radiation Patter
BeiDou_B1	1559-1563	Free Space	35.3	-4.52	-0.29	50 Ω	RHCP	Directional
		Ground Plane	44.4	-3.53	3.05			
GPS_L1	1563-1587	Free Space	48.4	-3.15	1.65			
		Ground Plane	54.8	-2.61	3.38			
Glonass_G1	1593-1610	Free Space	28.7	-5.43	-0.18			
		Ground Plane	39.9	-3.99	2.06			

LNA and Filter Electrical Properties			
Frequency (MHz)	BeiDou_B1	GPS_L1	GLONASS_G1
		1561	1575
LNA Gain (dB)	31.3	30.6	29.9
Noise Figure (dB)	1.9	1.8	2.0
Return Loss (dB)	< -10		
Input Voltage (V)	+ 1.8 to 5.5		
Current consumption (mA)	9 ± 3		
Outer Band Attenuation (dB)	> 70dB @ 600-960MHz ; > 60dB @ 1710-3000MHz		

LTE Electrical										
Band	Frequency (MHz)	Measurement		Efficiency (%)	Average Gain (dB)	Peak Gain (dBi)	Impedance	Polarization	Radiation Pattern	Max. input power
5G NR Band 71	617-698	Free Space	LTE 1	54.2	-2.66	3.47	50 Ω	Linear	Omni	10W
			LTE 2	45.5	-3.42	2.85				
		Ground Plane	LTE 1	73.0	-1.37	5.98				
			LTE 2	41.2	-3.85	3.88				
LTE700	698-824	Free Space	LTE 1	67.2	-1.73	3.93				
			LTE 2	65.6	-1.83	3.79				
		Ground Plane	LTE 1	65.7	-1.83	4.90				
			LTE 2	71.8	-1.44	7.04				
GSM800/900	824-960	Free Space	LTE 1	59.8	-2.24	4.09				
			LTE 2	67.8	-1.69	3.88				
		Ground Plane	LTE 1	62.5	-2.04	4.80				
			LTE 2	69.6	-1.58	7.26				
5G NR Band 1500	1427-1518	Free Space	LTE 1	49.3	-3.07	2.97				
			LTE 2	49.3	-3.08	2.63				
		Ground Plane	LTE 1	35.3	-4.52	1.91				
			LTE 2	45.6	-3.41	4.32				
5G NR N66	1710-2200	Free Space	LTE 1	62.9	-2.01	5.41				
			LTE 2	65.1	-1.86	4.73				
		Ground Plane	LTE 1	49.7	-3.03	5.66				
			LTE 2	42.2	-3.74	5.41				
LTE2600	2300-2690	Free Space	LTE 1	43.9	-3.57	6.04				
			LTE 2	64.9	-1.88	6.54				
		Ground Plane	LTE 1	46.2	-3.35	5.83				
			LTE 2	56.9	-2.45	5.99				
5G NR N77	3300-4200	Free Space	LTE 1	51.9	-2.85	4.37				
			LTE 2	52.9	-2.76	4.46				
		Ground Plane	LTE 1	54.7	-2.62	6.86				
			LTE 2	47.7	-3.22	6.44				
5G NR N78	3300-3800	Free Space	LTE 1	52.8	-2.77	4.05				
			LTE 2	53.7	-2.70	4.46				
		Ground Plane	LTE 1	54.8	-2.62	6.86				
			LTE 2	47.1	-3.27	6.44				
5G NR N79	4400-5000	Free Space	LTE 1	52.0	-2.84	7.21				
			LTE 2	62.4	-2.05	7.59				
		Ground Plane	LTE 1	47.0	-3.28	6.36				
			LTE 2	55.2	-2.58	6.41				
LTE5200	5150-5925	Free Space	LTE 1	45.8	-3.39	5.28				
			LTE 2	57.9	-2.37	6.70				
		Ground Plane	LTE 1	47.4	-3.24	5.93				
			LTE 2	51.8	-2.86	7.75				

Mechanical	
Dimensions	Ø80mm x 18 mm
Weight	113g
Material	ASA
Connector	SMA(M)ST
Cable	2m TGC-1.5DS

Environmental	
Waterproof Rating	IP67
Operation Temperature	-40°C to 85°C
Storage Temperature	-40°C to 85°C
Relative Humidity	Non-condensing 65°C 95% RH
RoHs Compliant	Yes

**Note:** The antenna was measured with 300mm 1.5DS cable in free space.

### 3. Antenna Characteristics

#### 3.1 Test Setup

AUT



Vector Network Analyzer



In Free space



On 30X30cm Ground plane



### 3.2 Return Loss

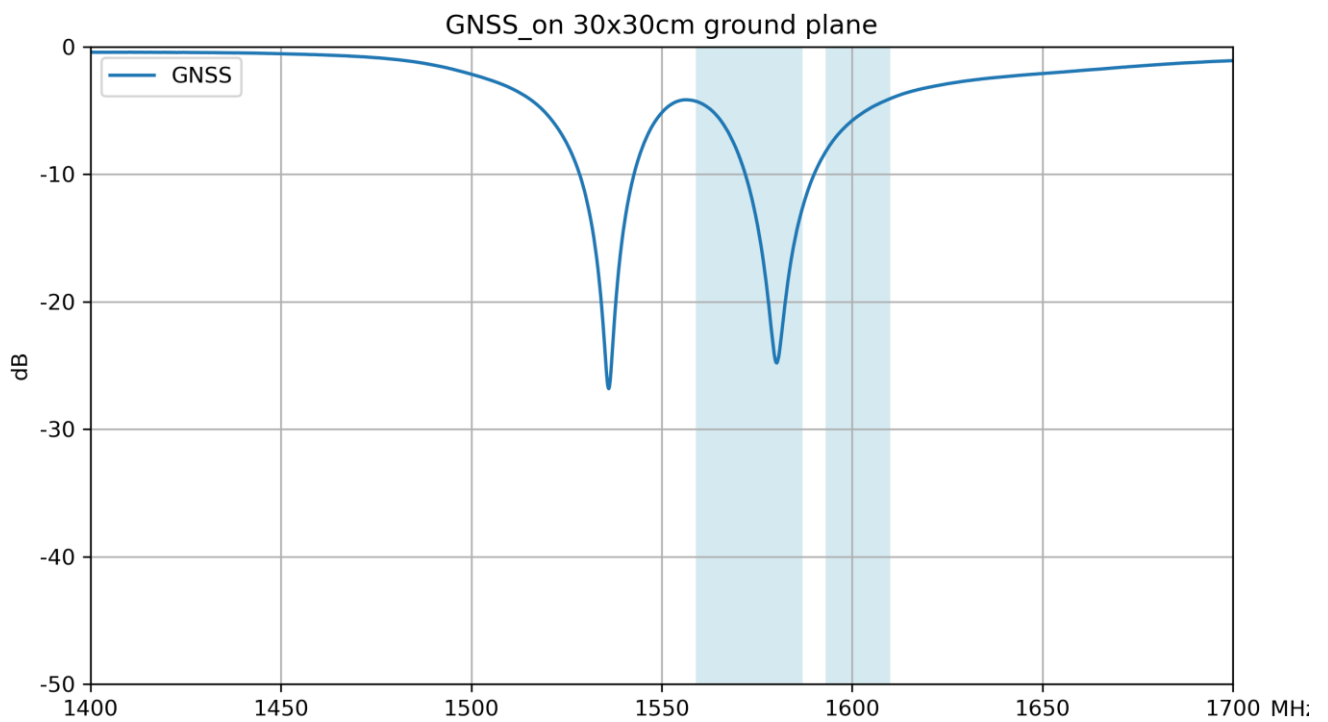
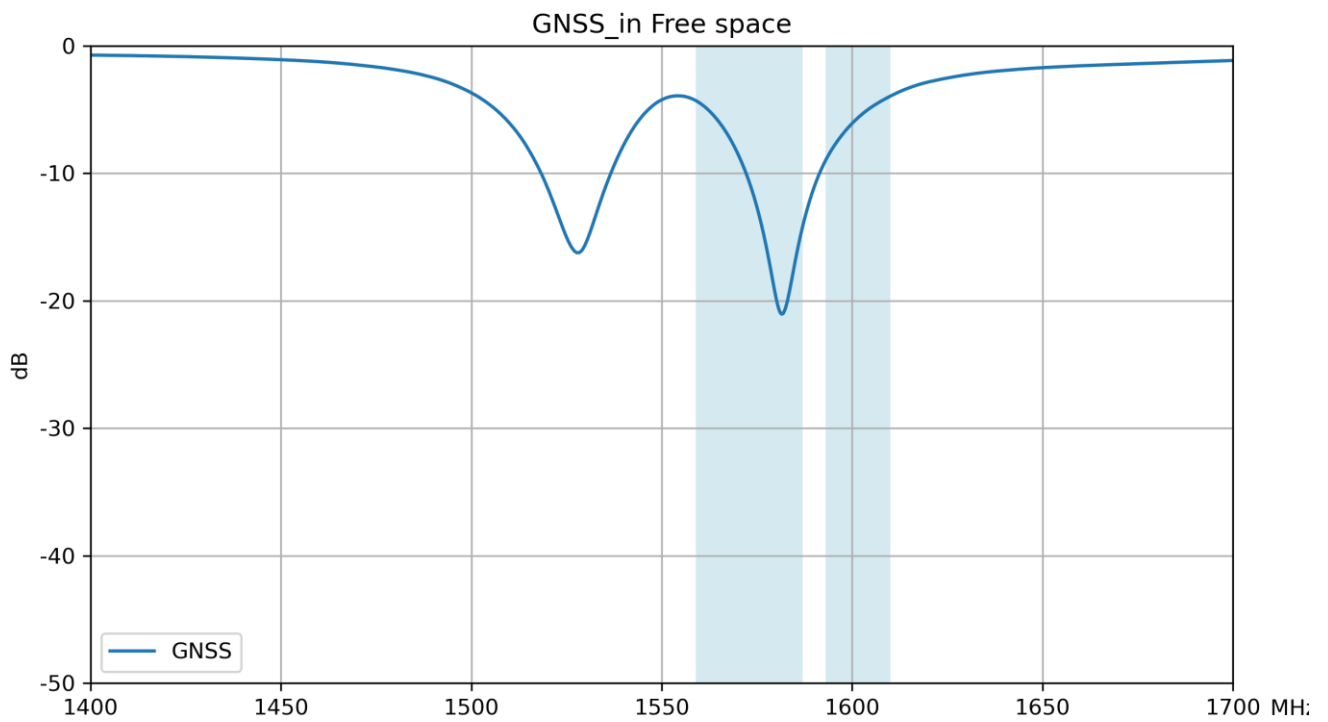

### 3.3 Efficiency

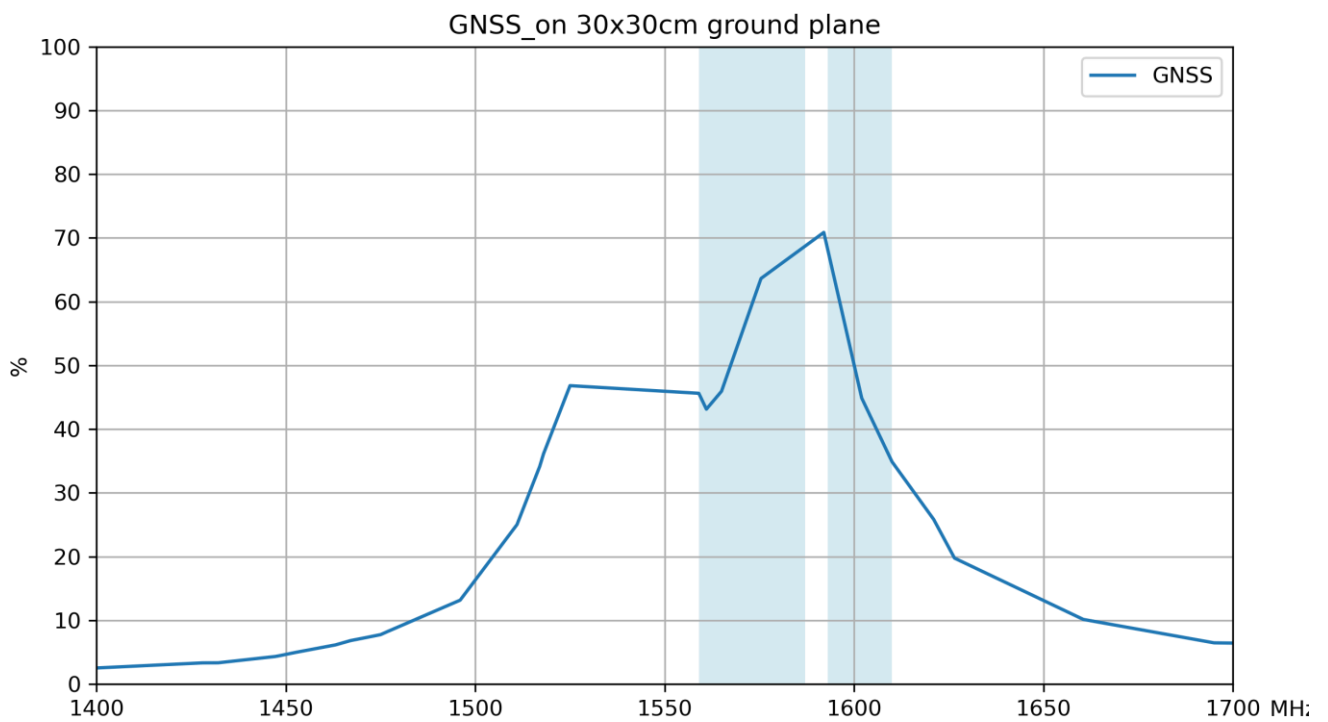
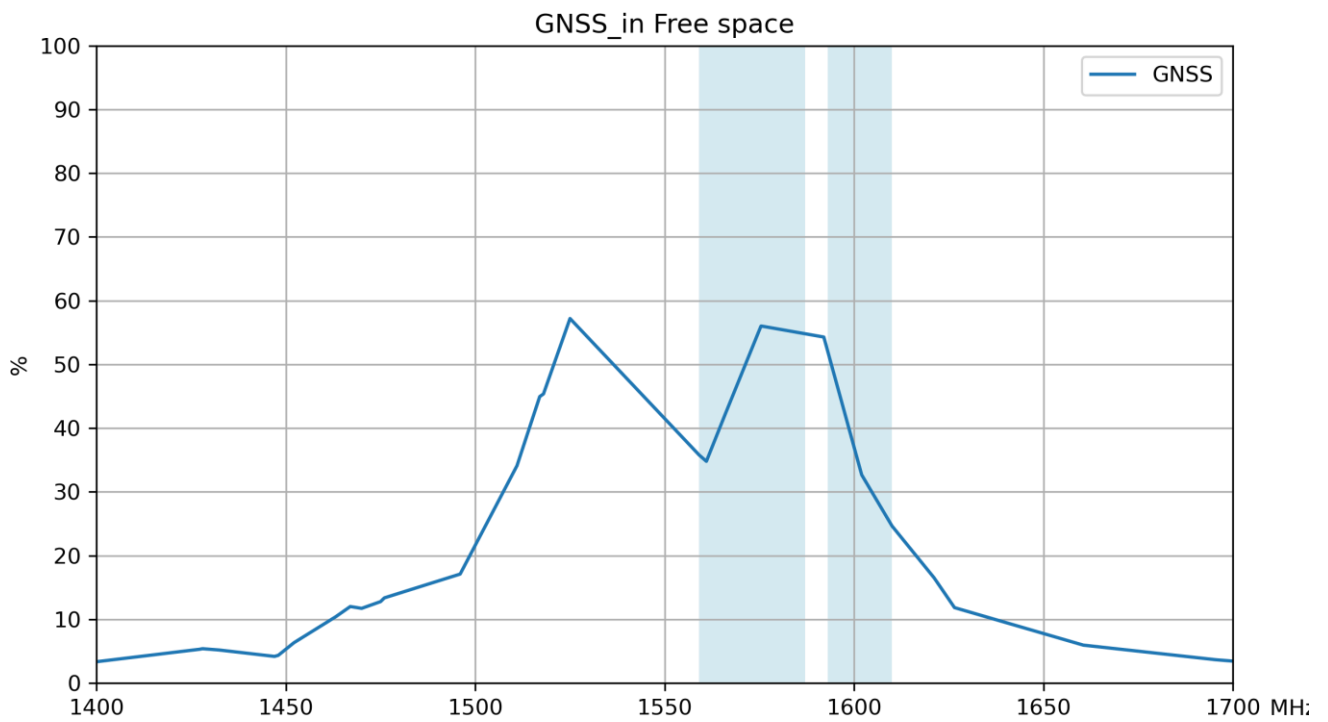

### 3.4 Average Gain

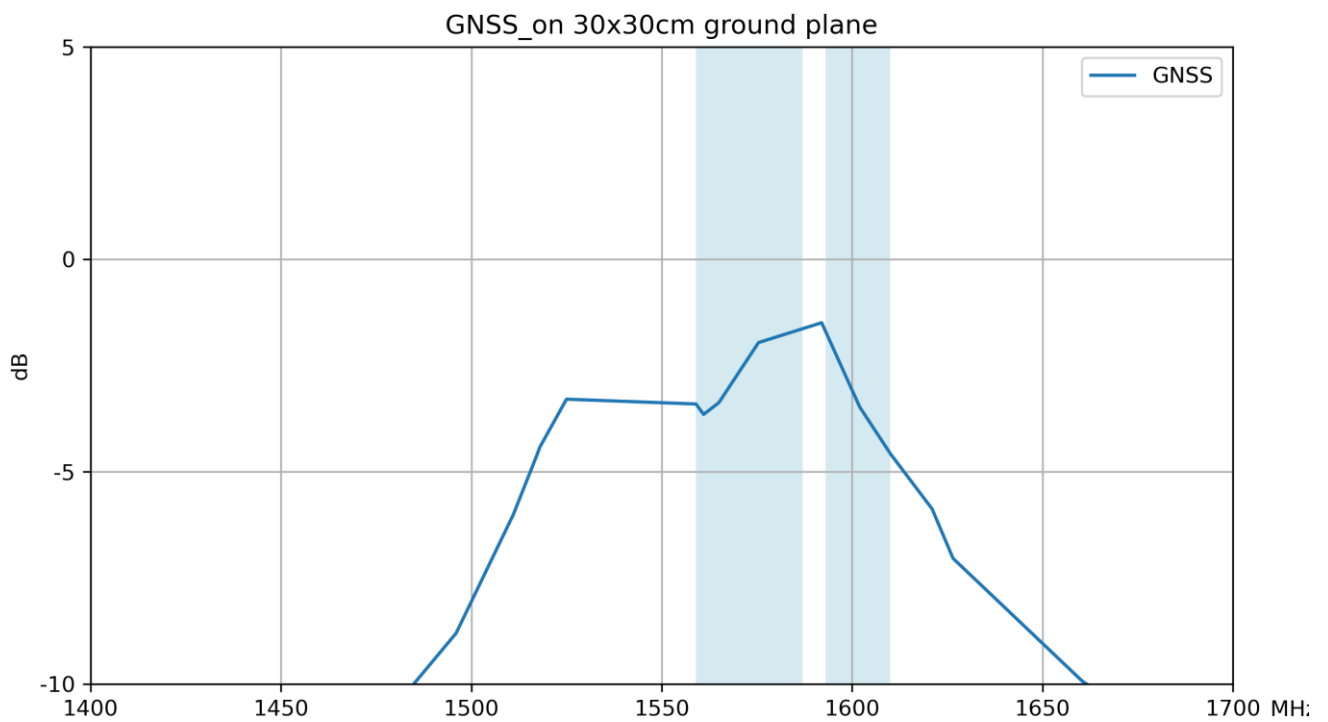
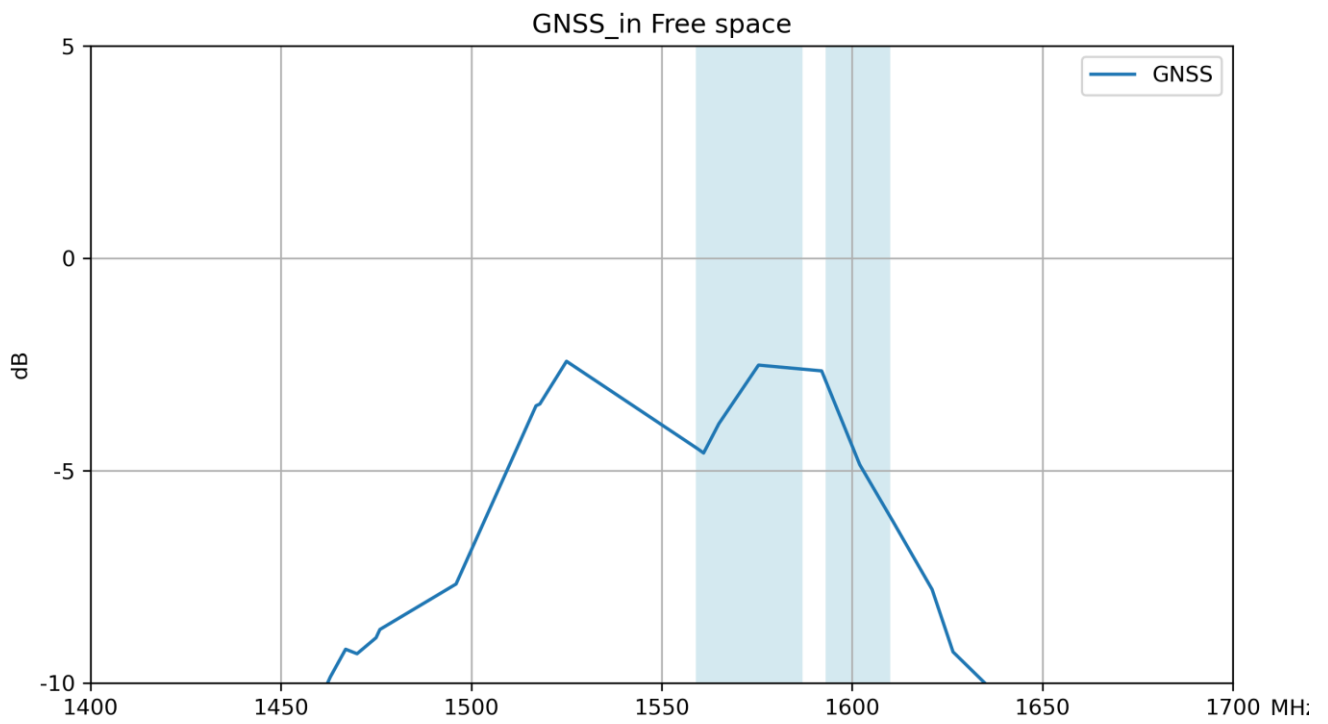

### 3.5 Peak Gain

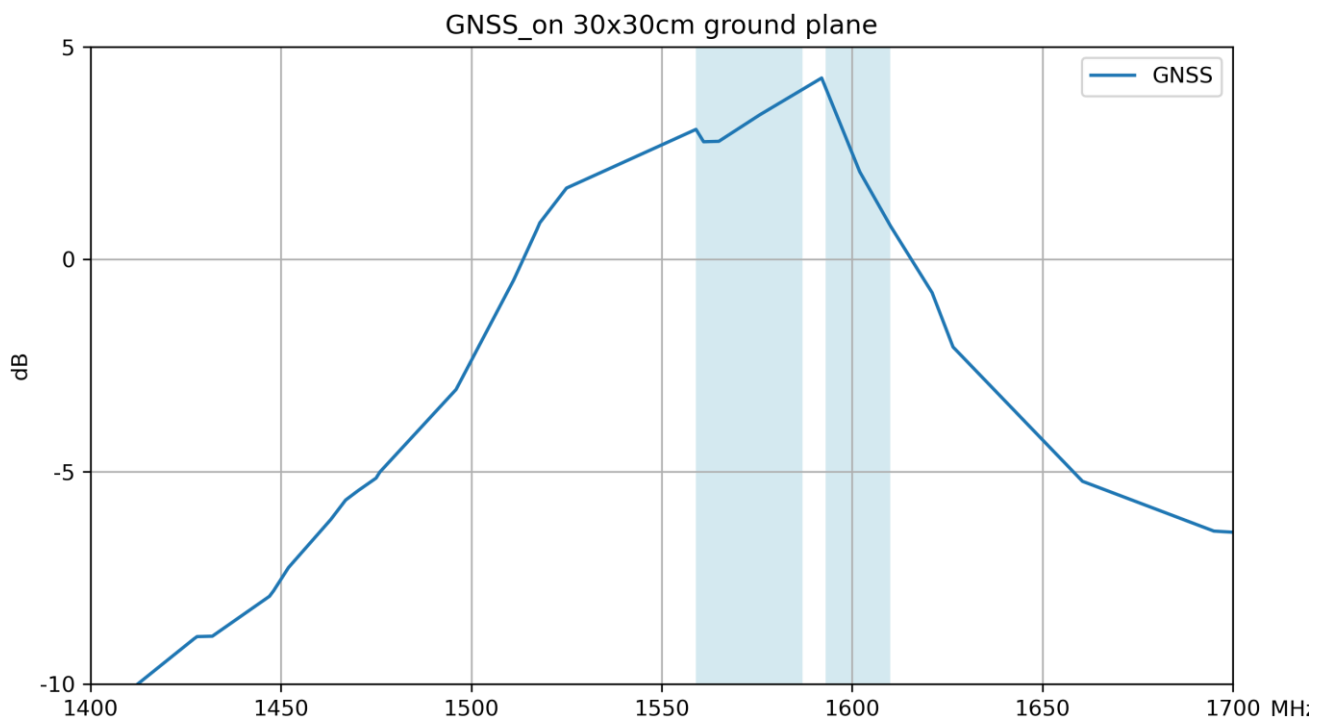
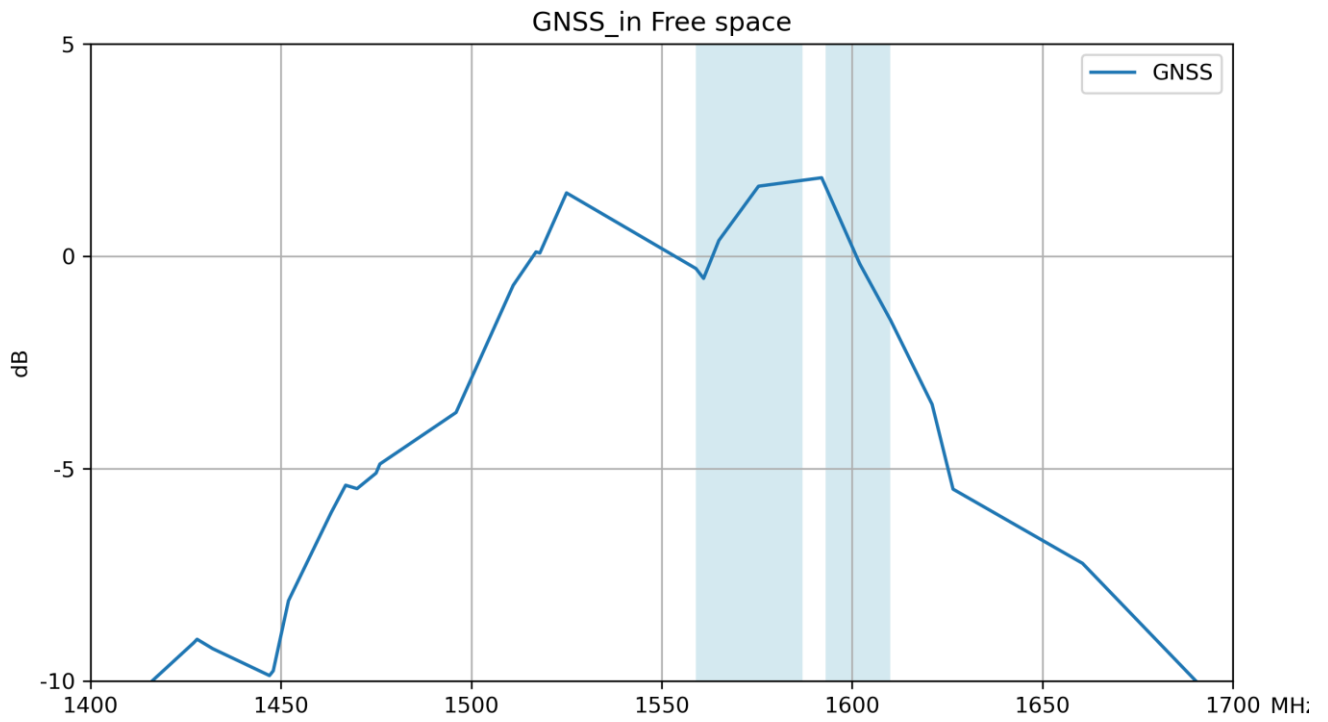

### 3.6 Return Loss

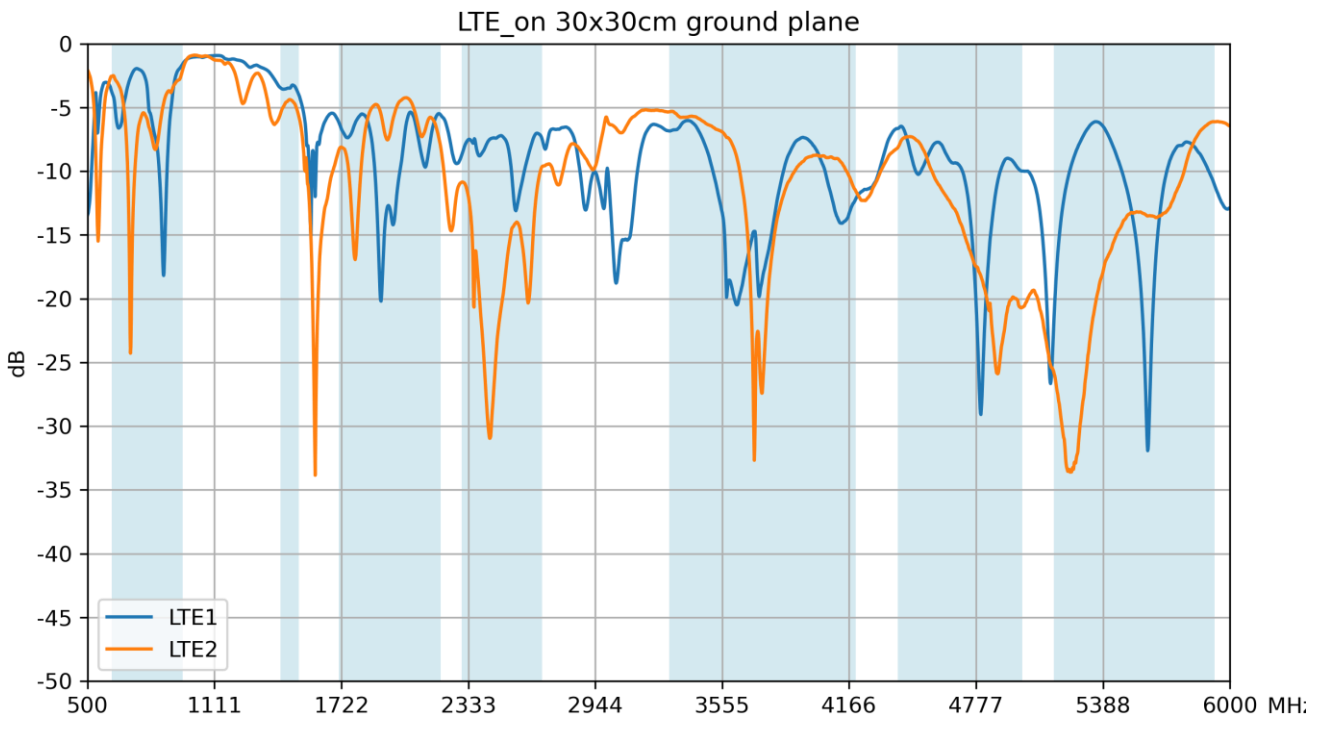
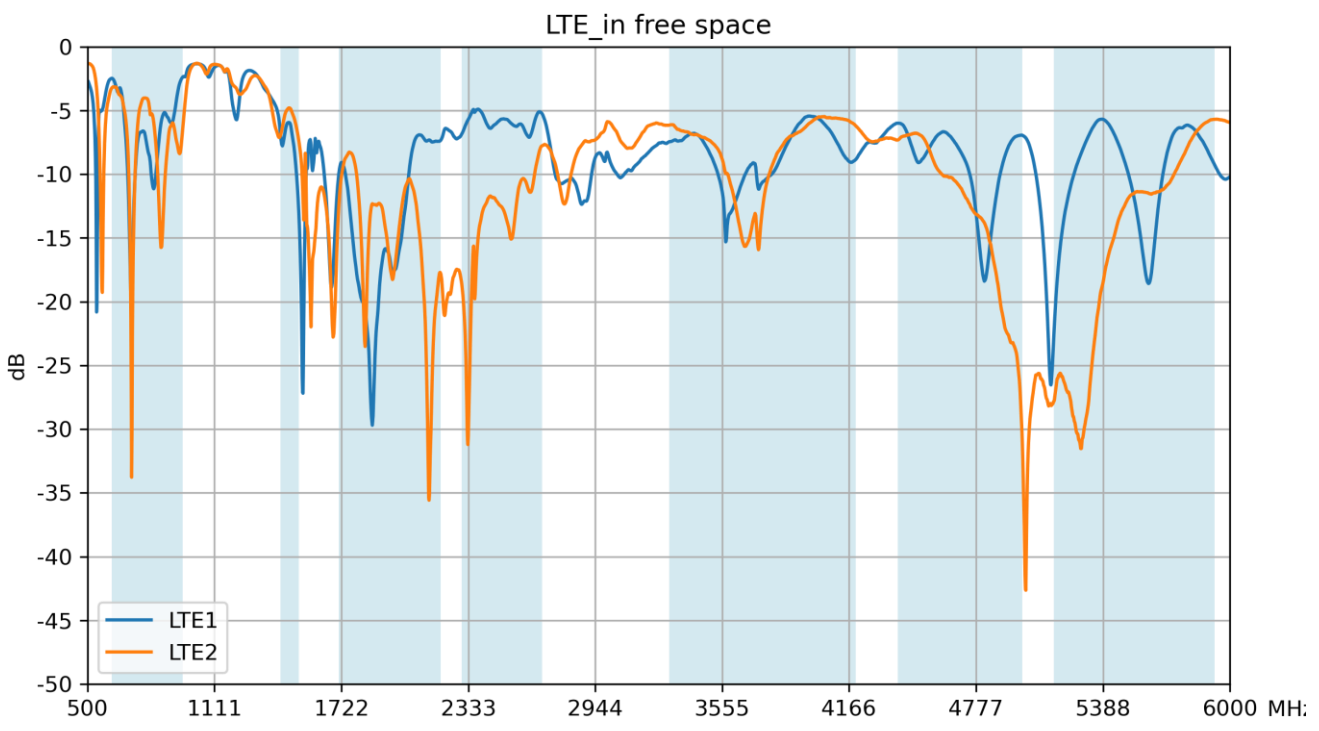

### 3.7 Isolation

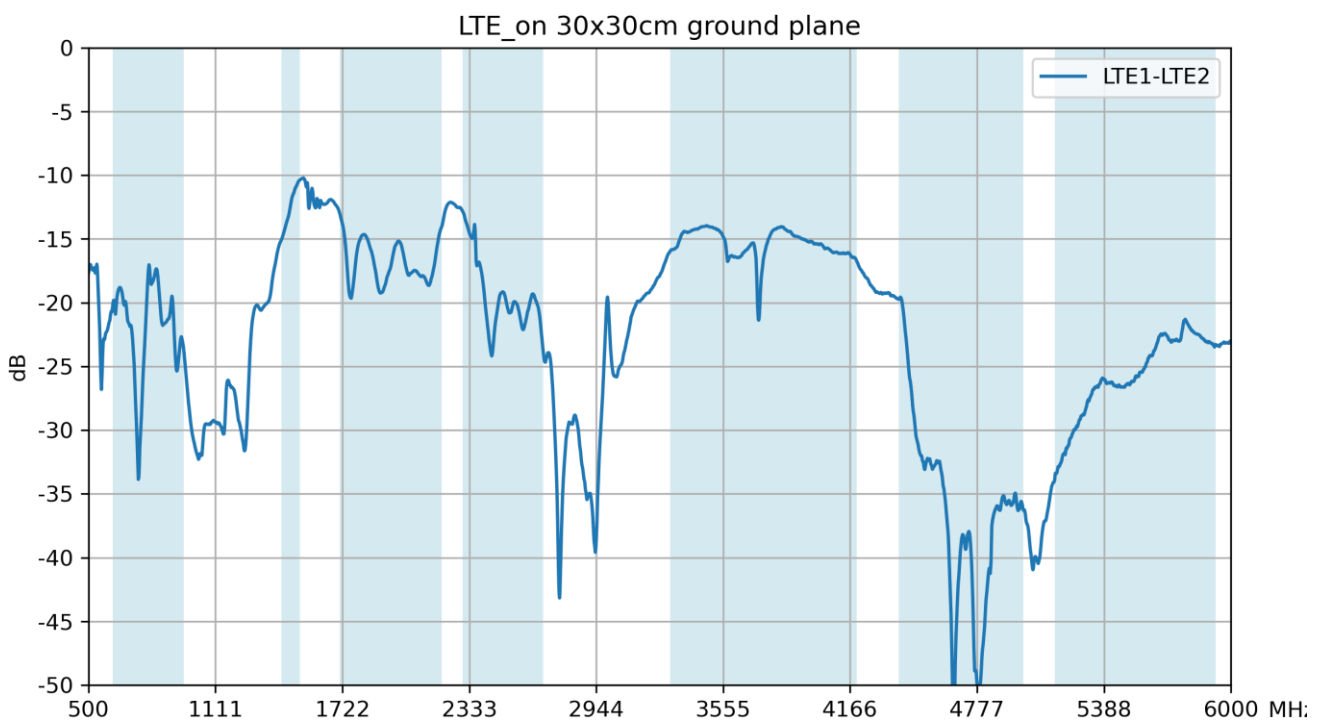
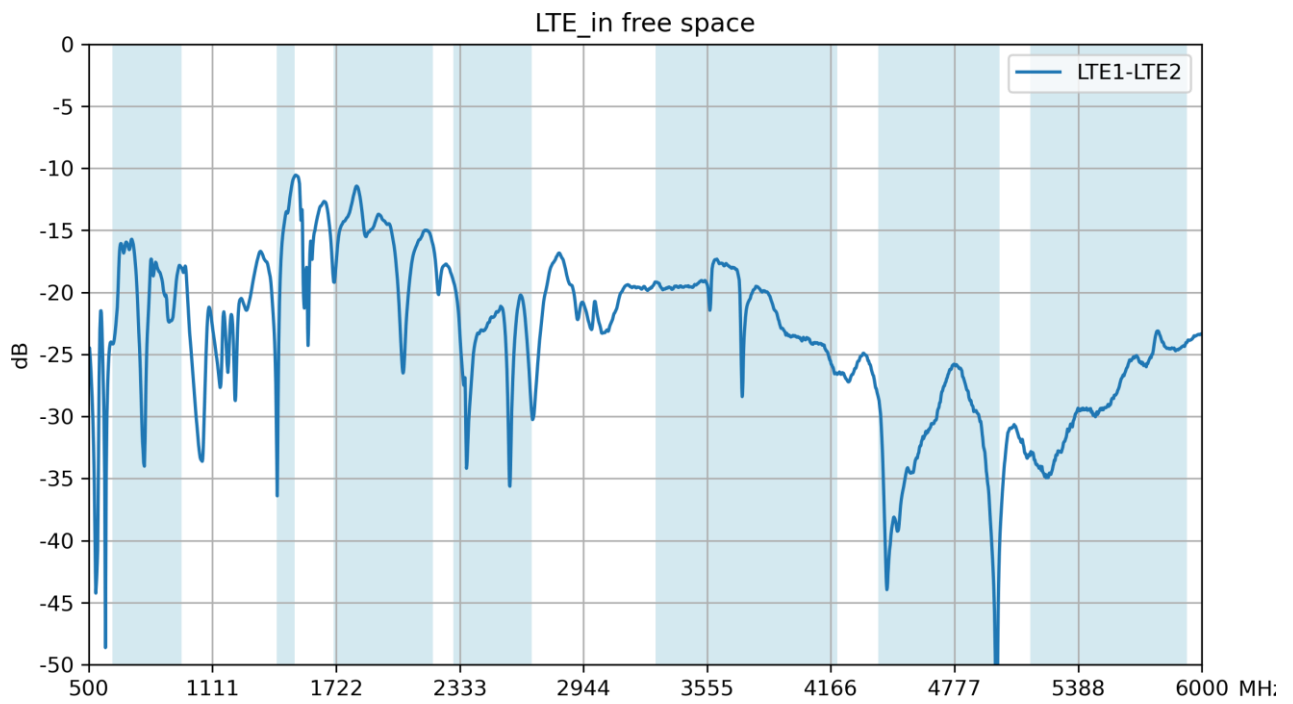

### 3.8 Efficiency

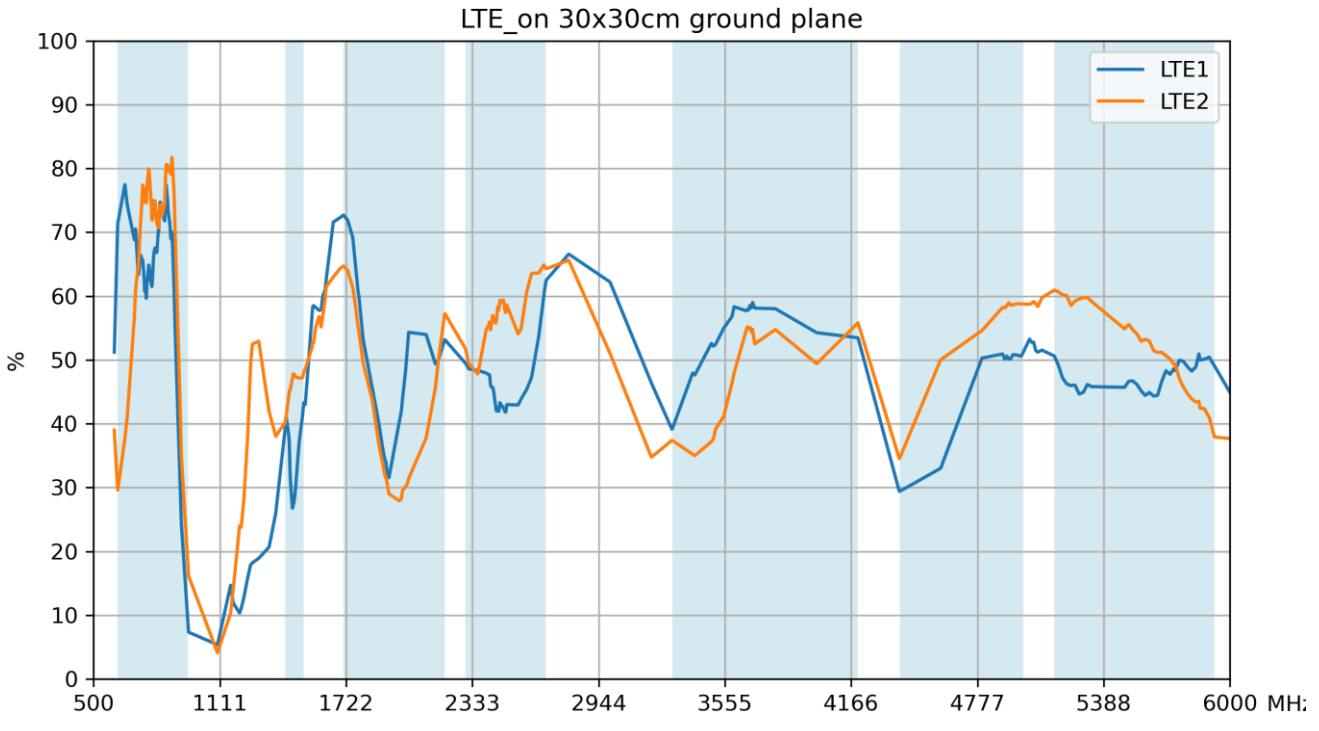
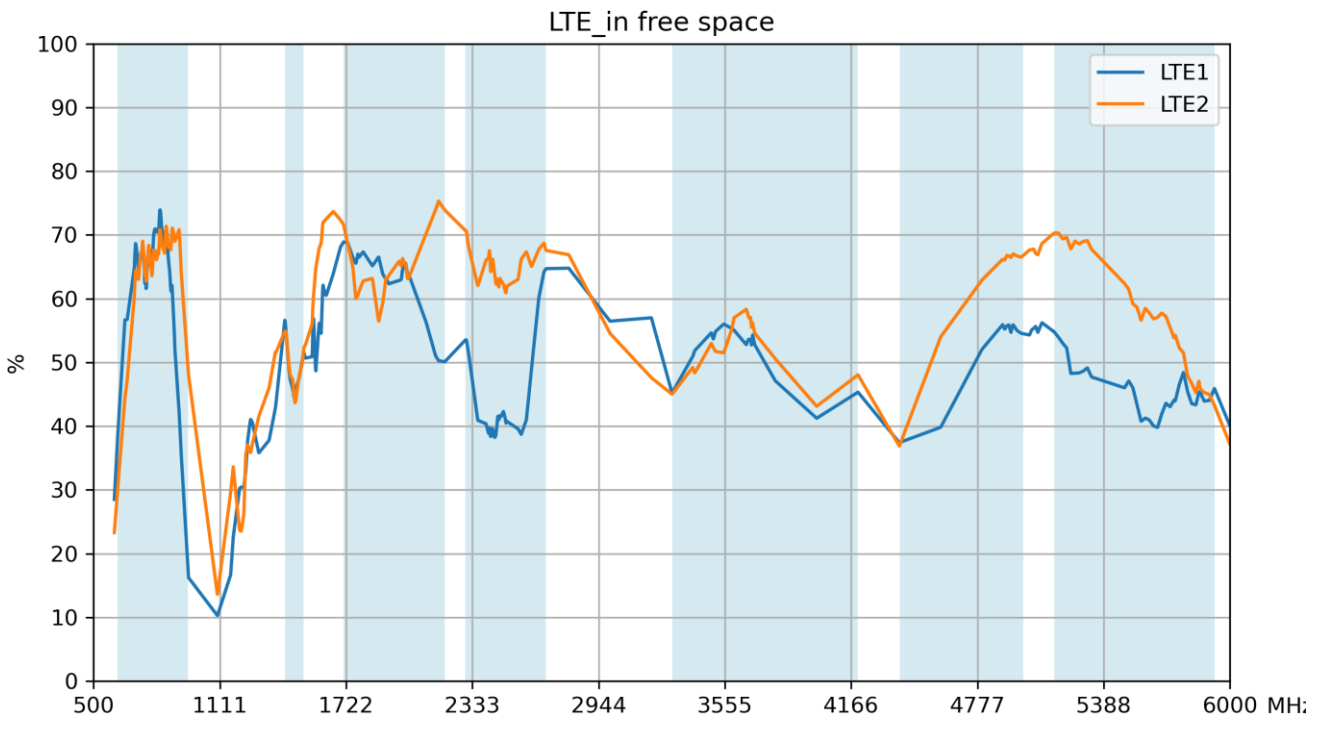

### 3.9 Average Gain

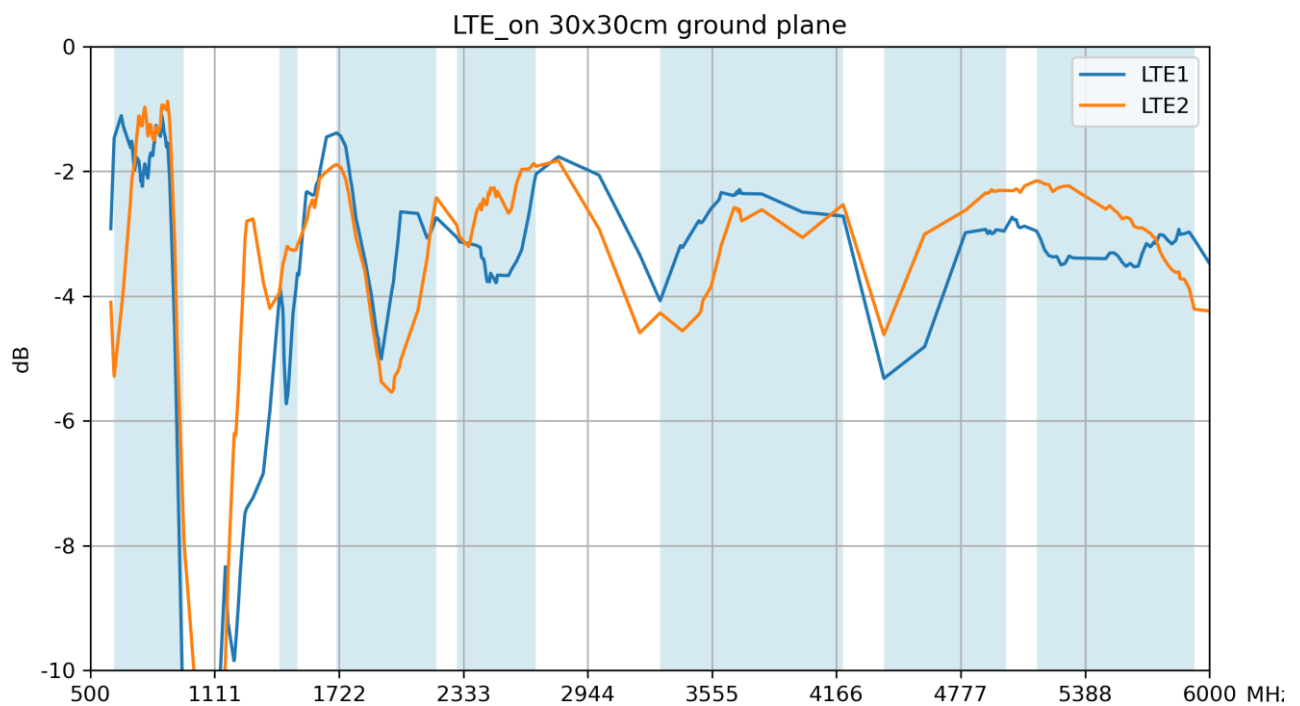
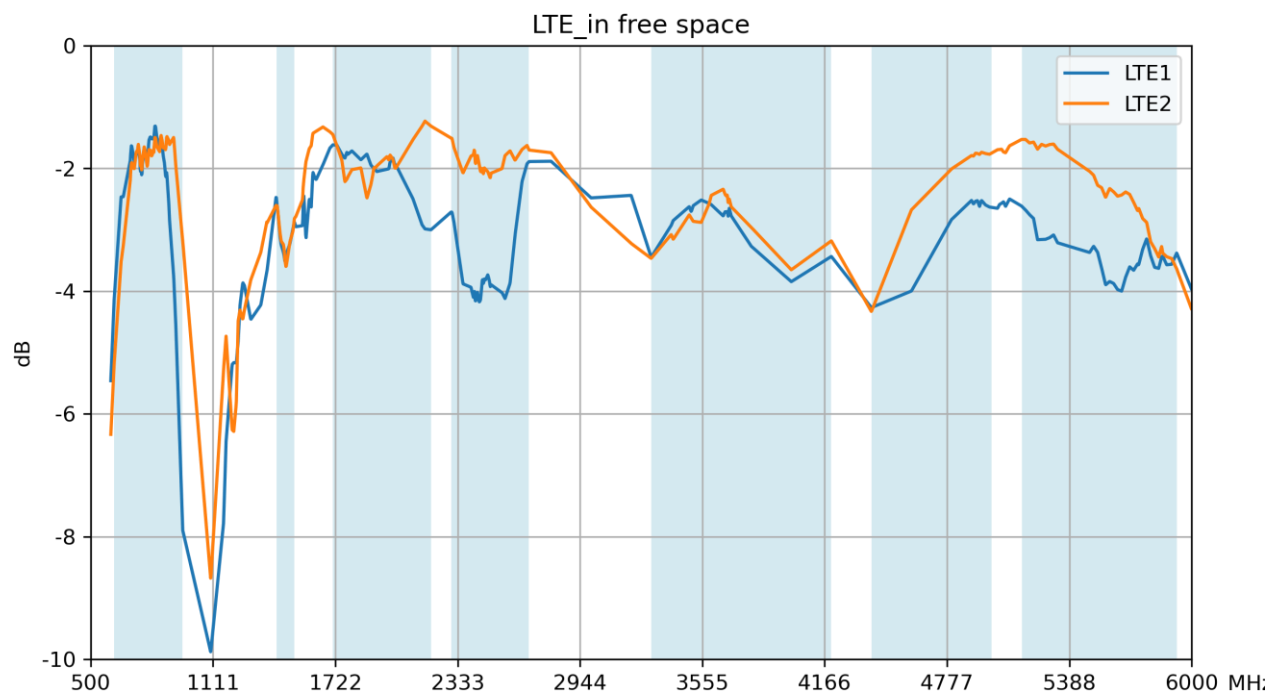



### 3.10 Peak Gain

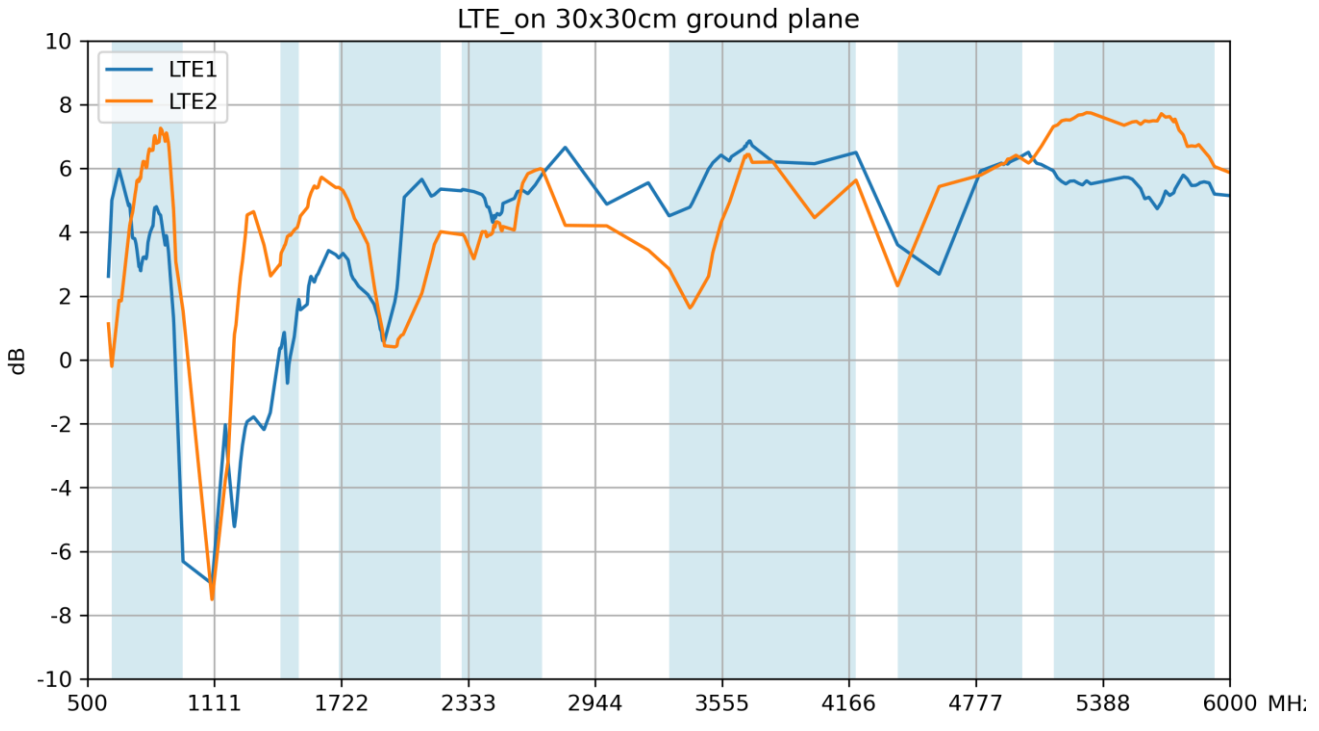
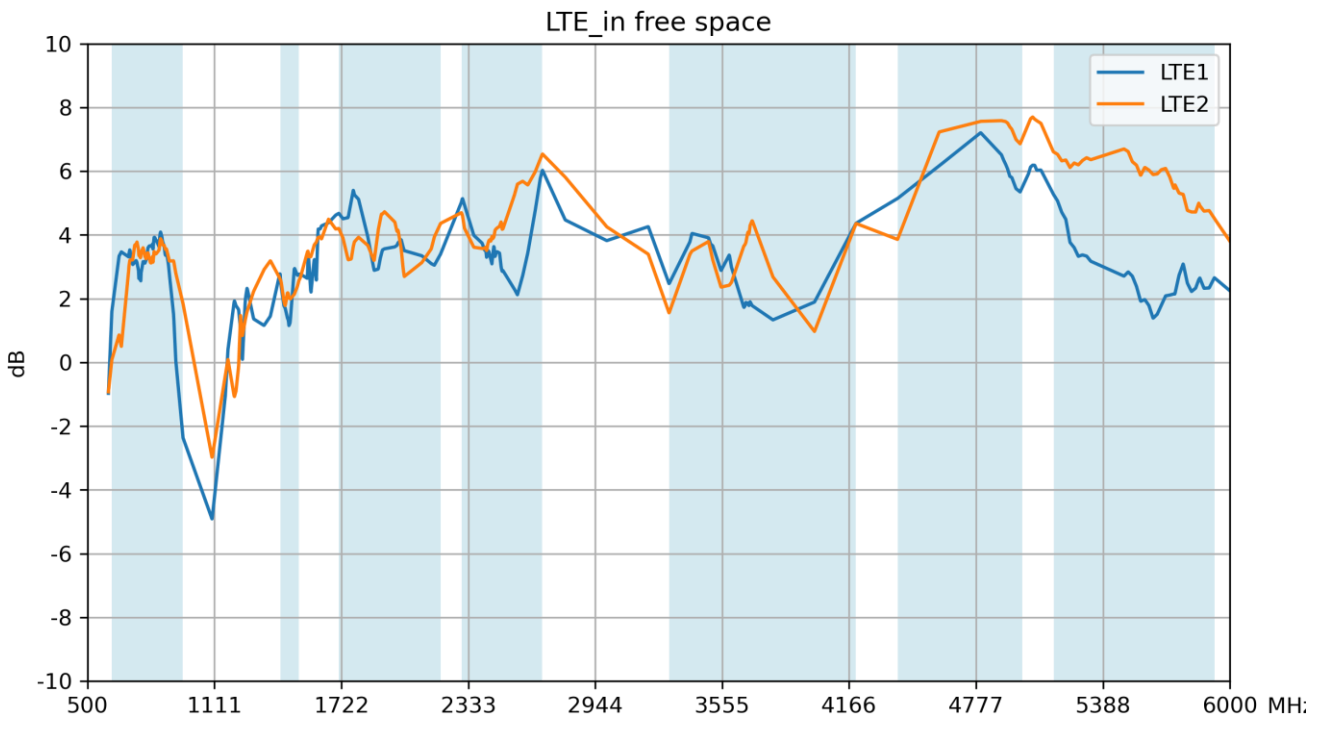

## 4. Radiation Patterns

### 4.1 Test Setup

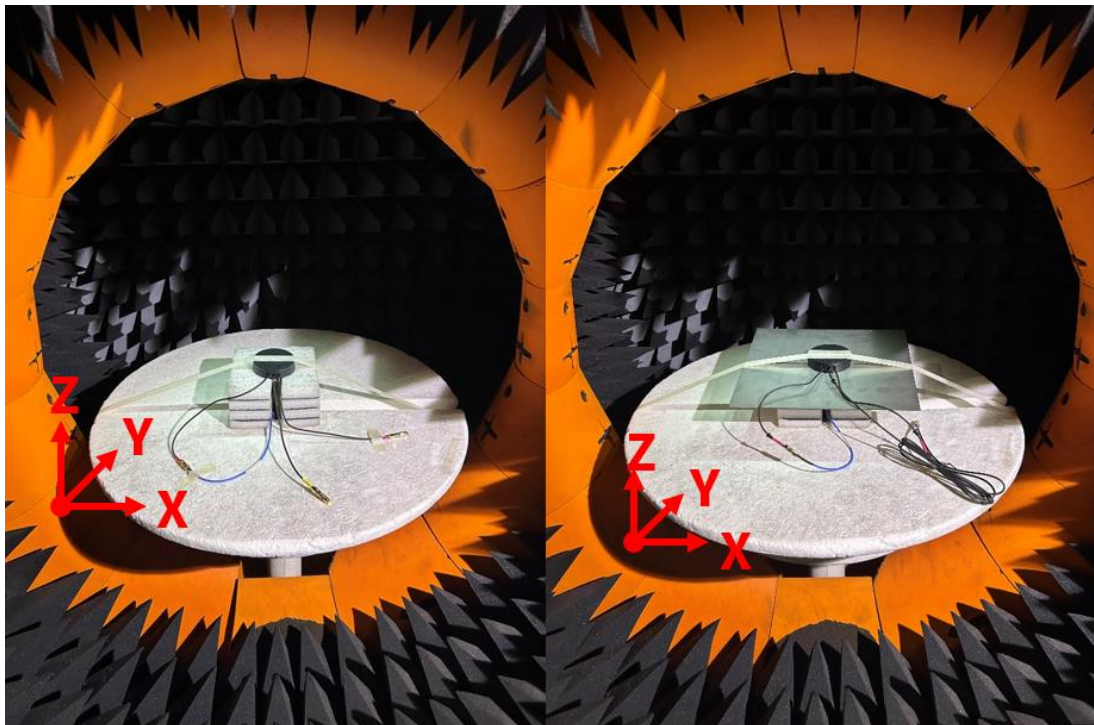
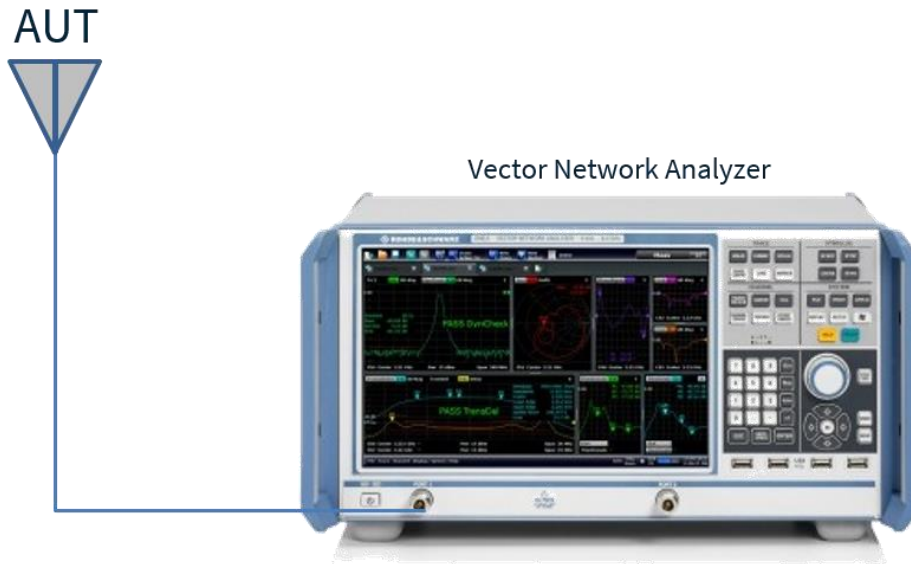

In Free space

On 30X30cm Ground plane

4.2 LTE 1 in Free Space Patterns at 652 MHz

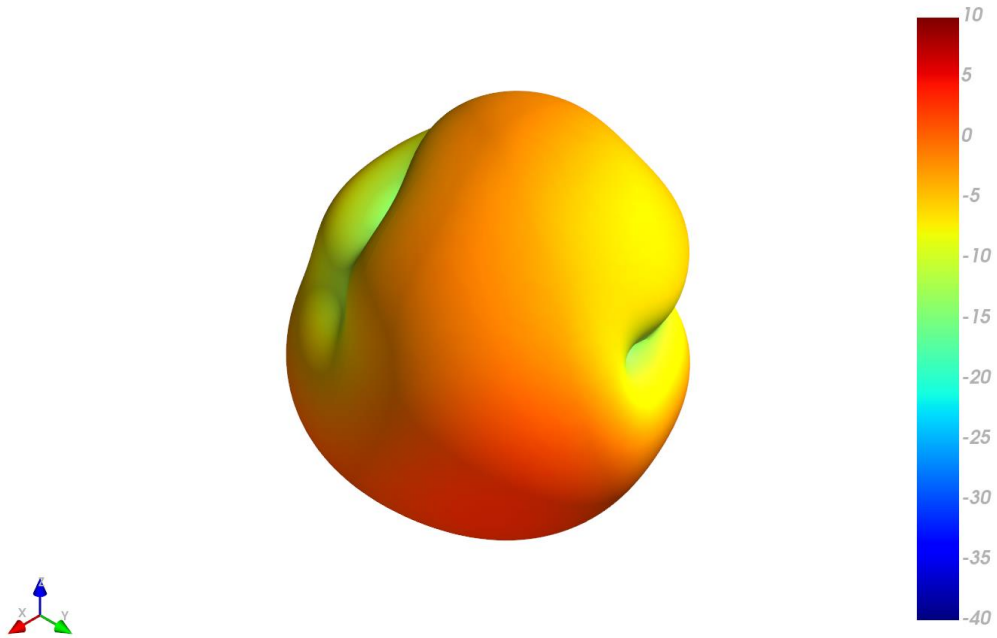

XY Plane      XZ Plane      YZ Plane

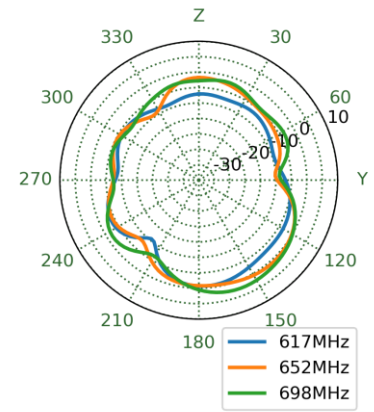
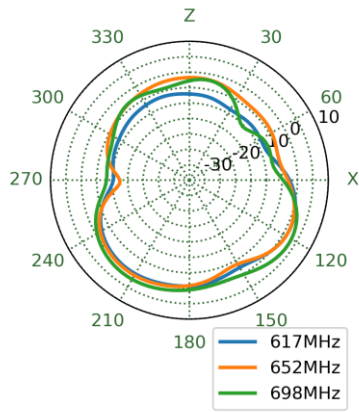
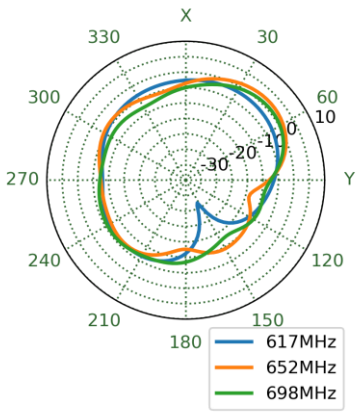

4.3 LTE 1 in Free Space Patterns at 751 MHz

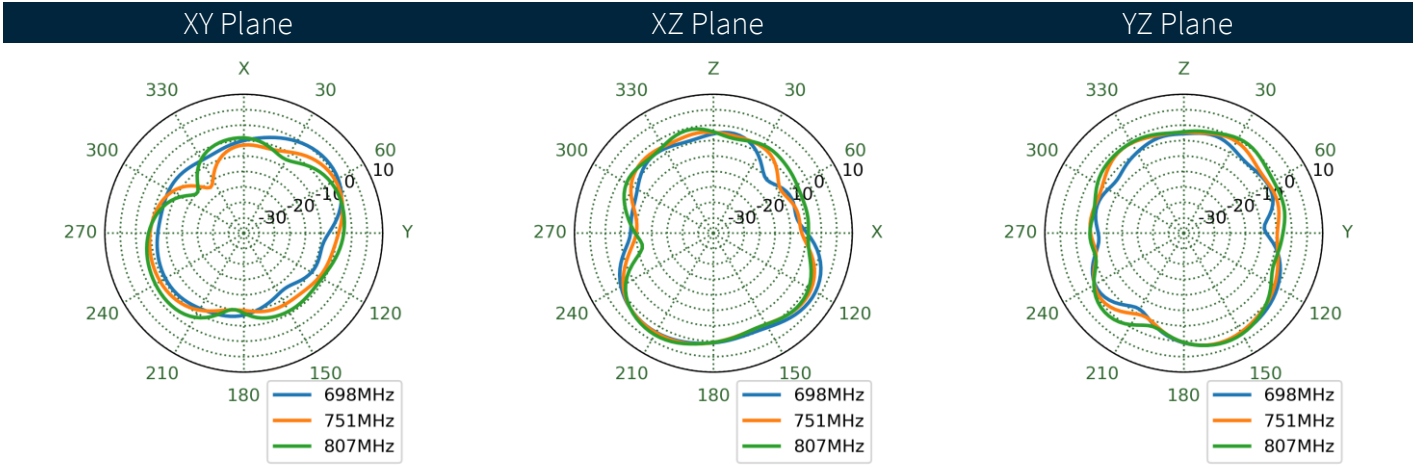
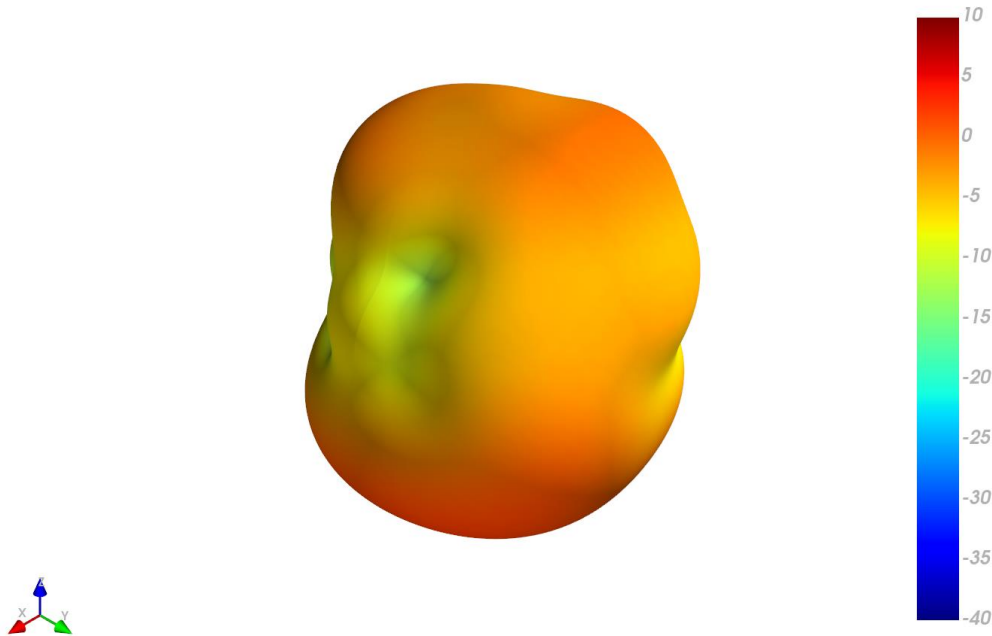

4.4 LTE 1 in Free Space Patterns at 890 MHz

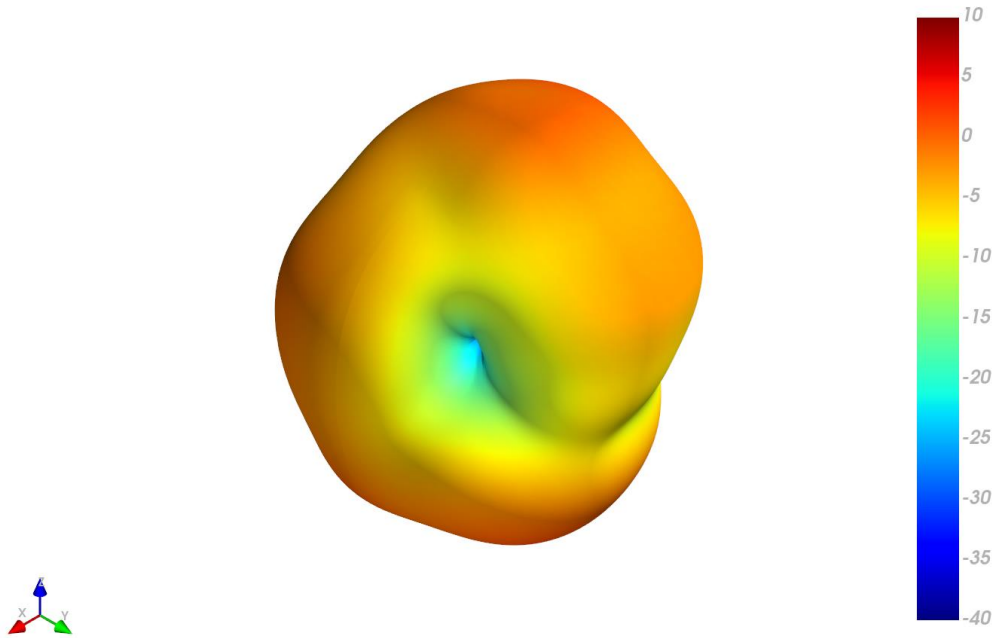

XY Plane XZ Plane YZ Plane

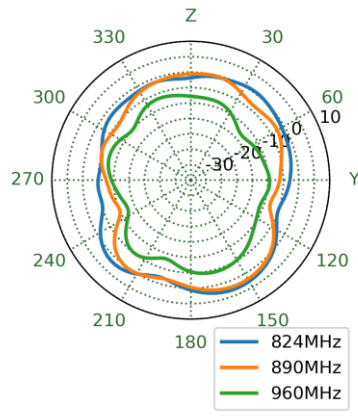
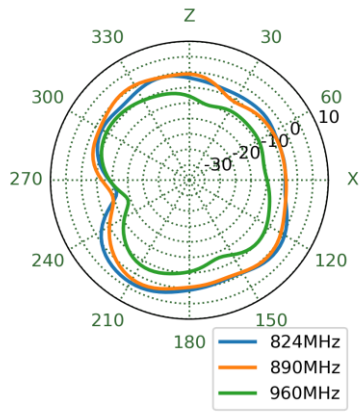
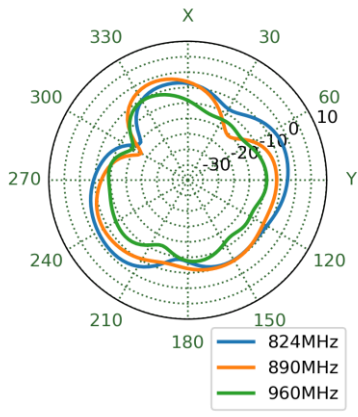

4.5 LTE 1 in Free Space Patterns at 1470 MHz

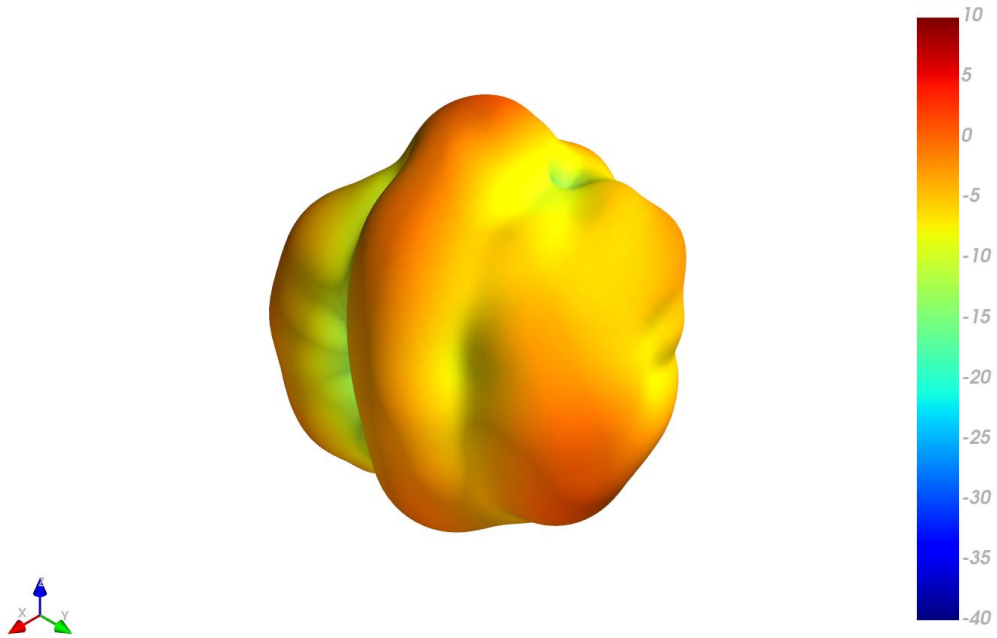

XY Plane XZ Plane YZ Plane

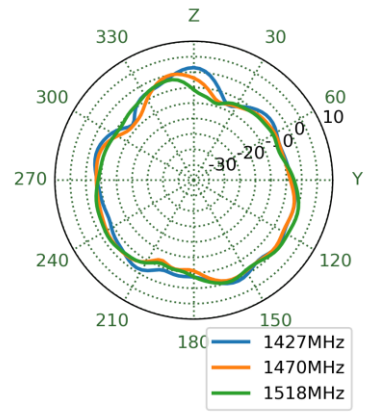
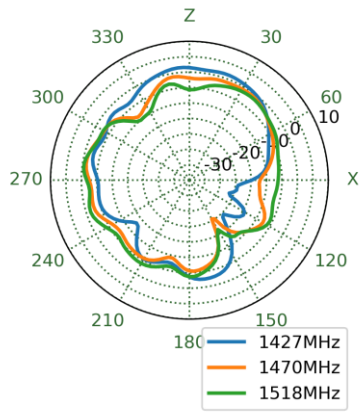
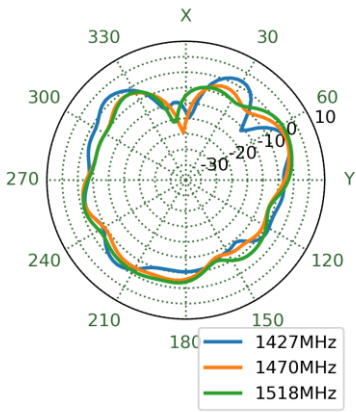

4.6 LTE 1 in Free Space Patterns at 1805 MHz

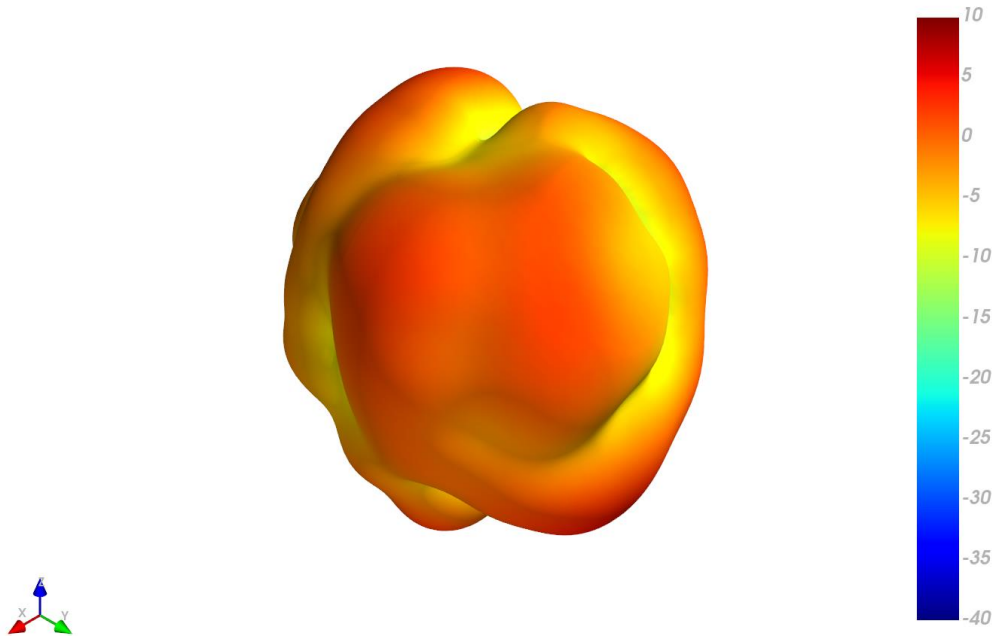

XY Plane XZ Plane YZ Plane

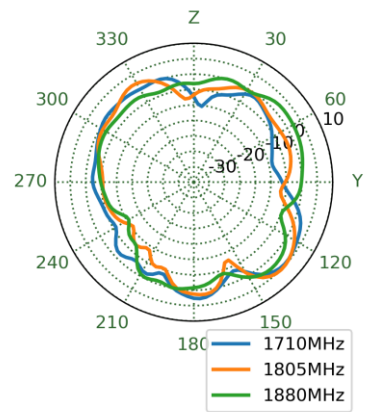
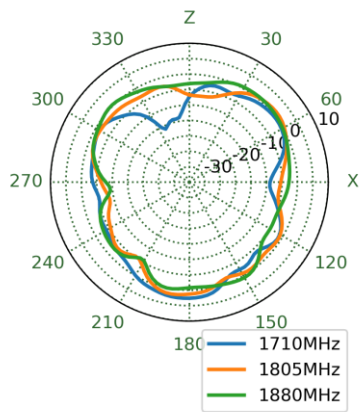
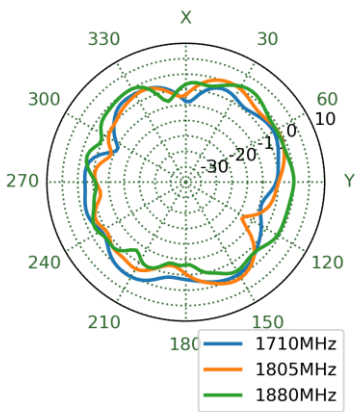

4.7 LTE 1 in Free Space Patterns at 1920 MHz

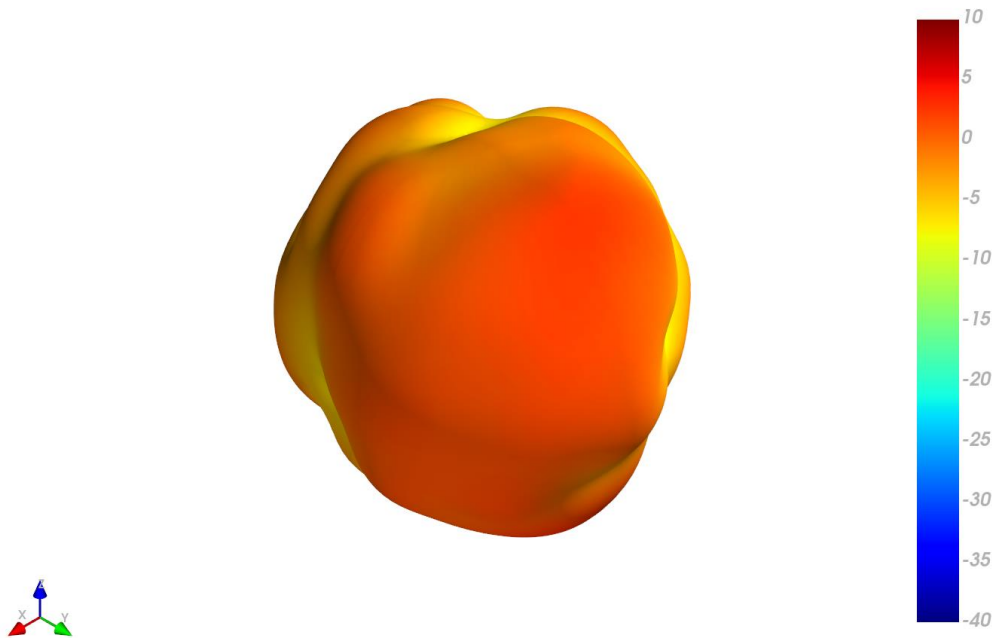

XY Plane XZ Plane YZ Plane

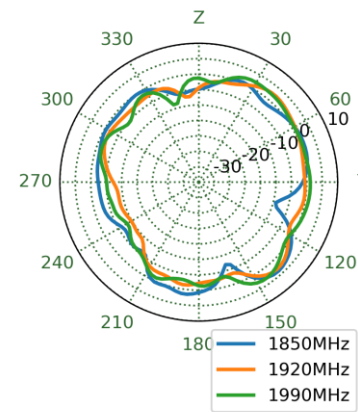
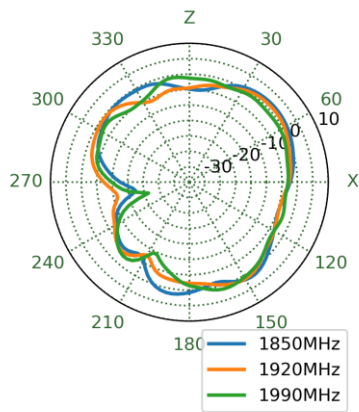
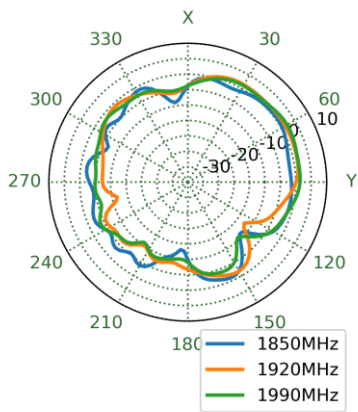



4.8 LTE 1 in Free Space Patterns at 1990 MHz

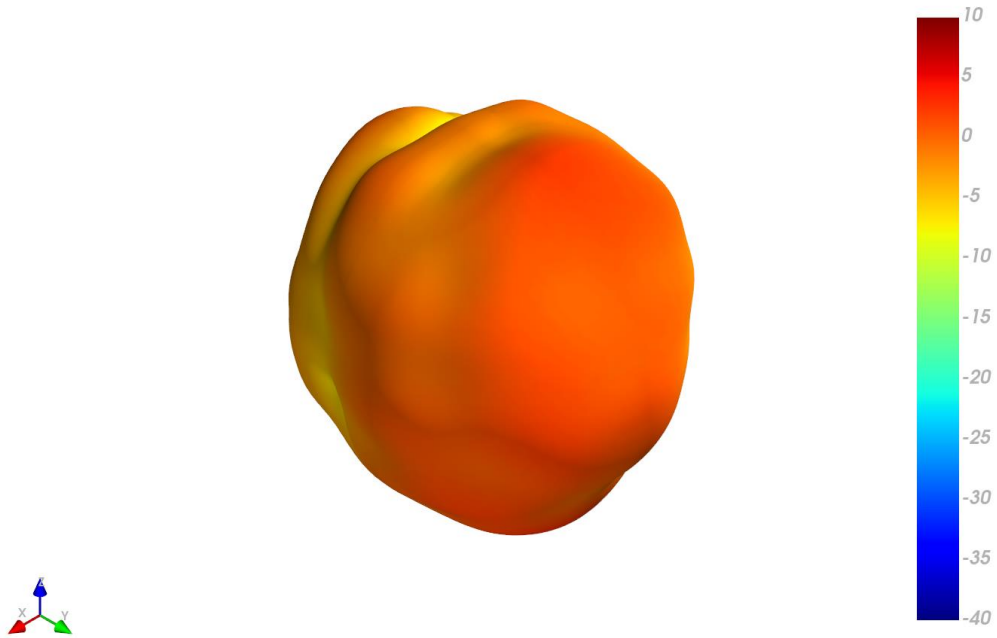

XY Plane XZ Plane YZ Plane

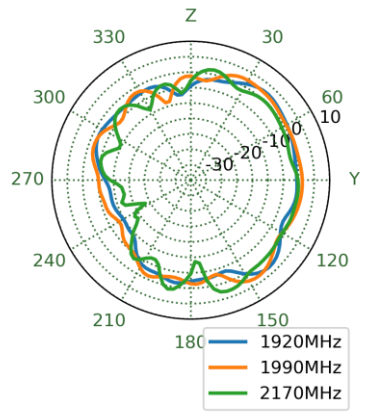
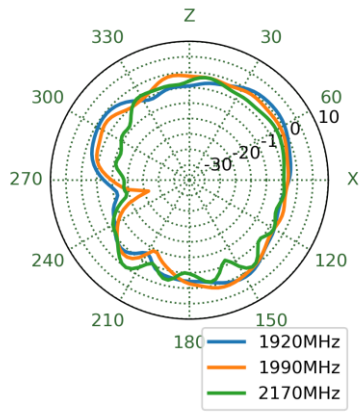
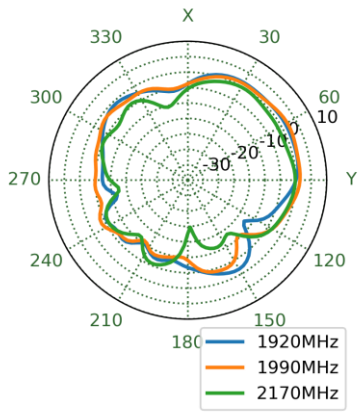

4.9 LTE 1 in Free Space Patterns at 2595 MHz

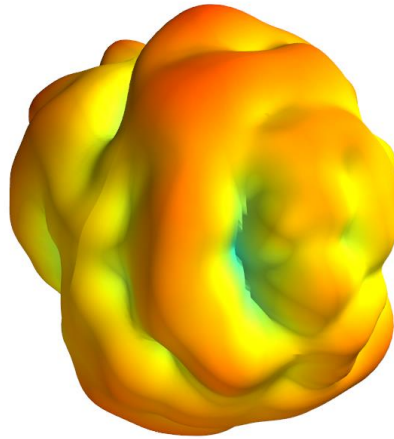

XY Plane XZ Plane YZ Plane

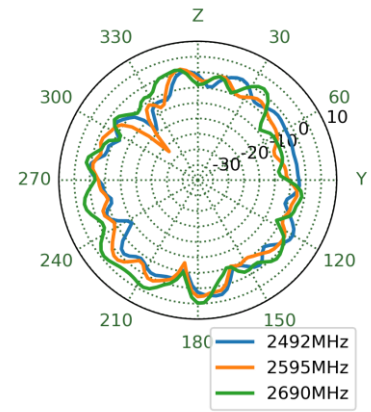
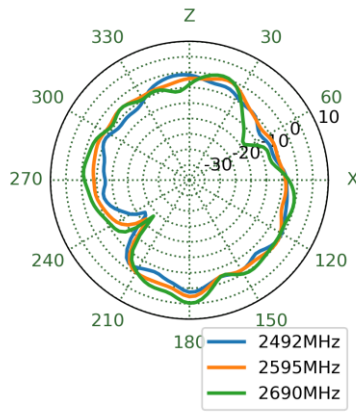
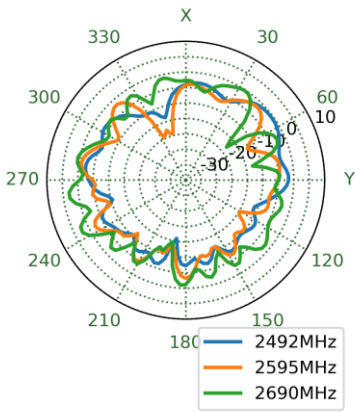

## 4.10 LTE 1 in Free Space Patterns at 3550 MHz

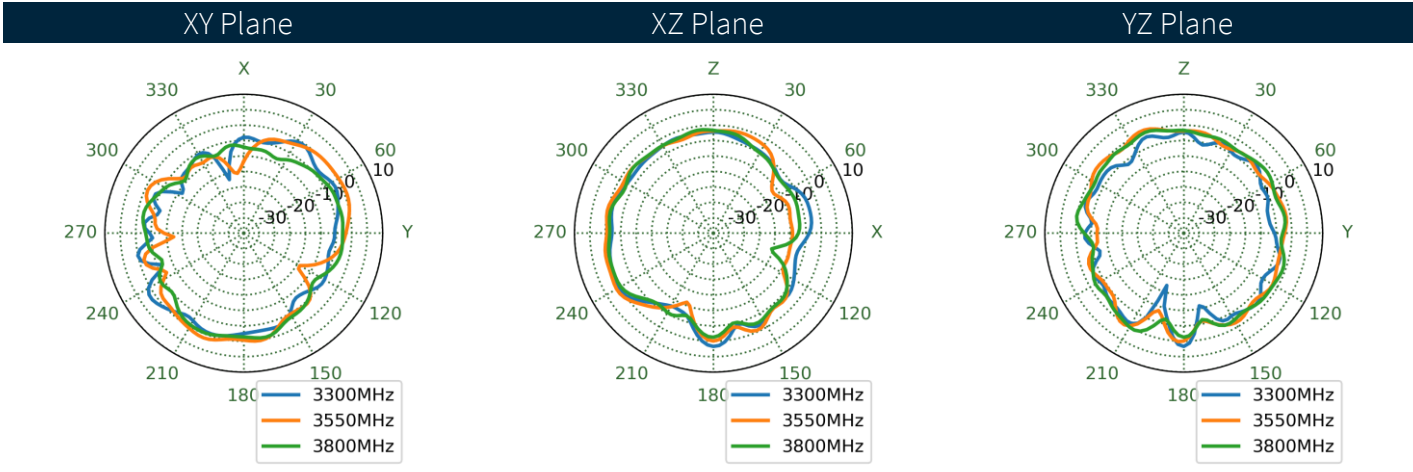
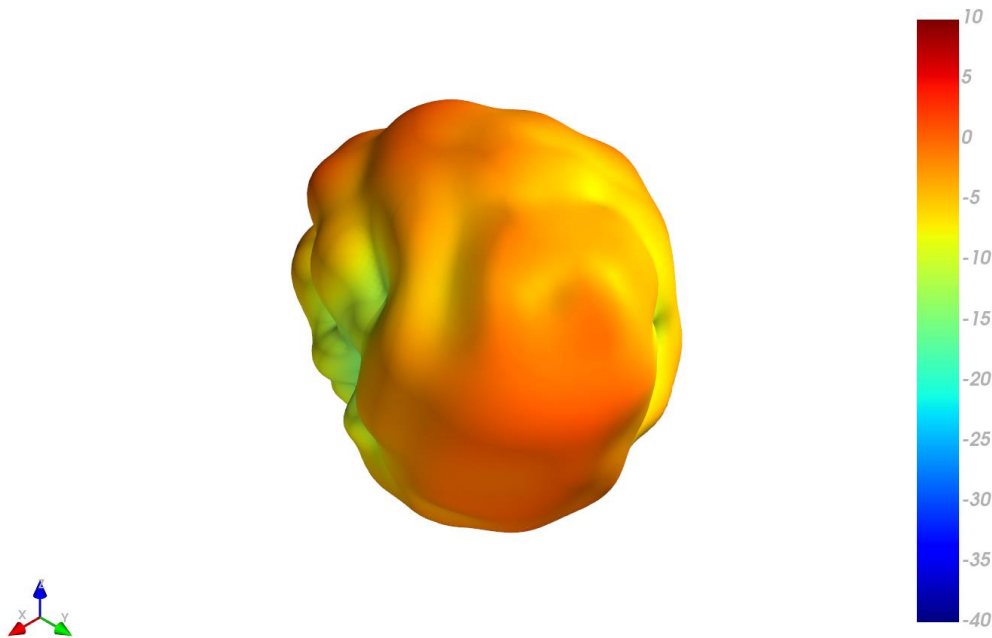

4.11 LTE 1 in Free Space Patterns at 4600 MHz

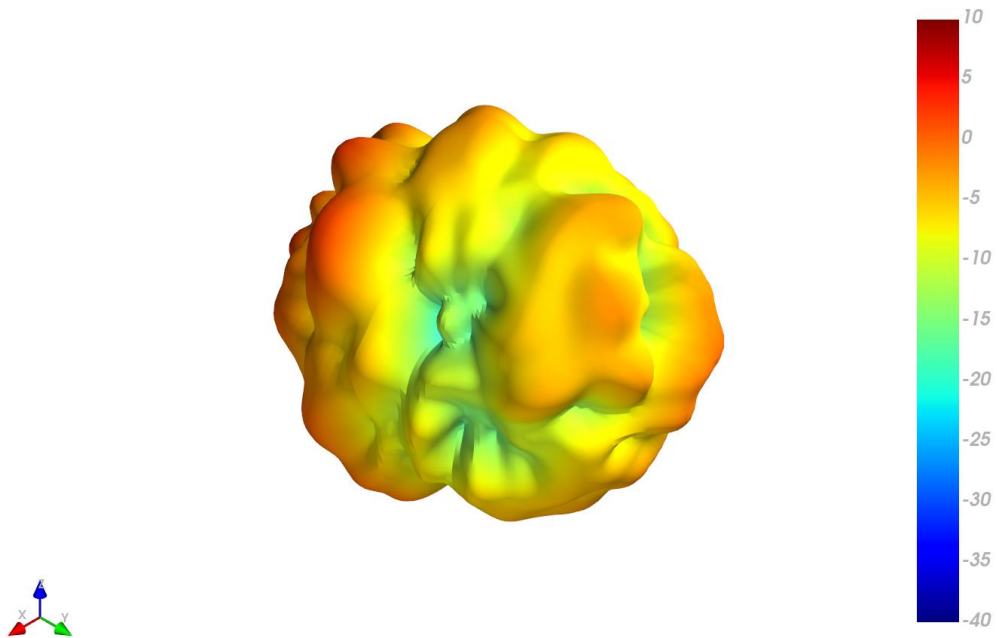

XY Plane XZ Plane YZ Plane

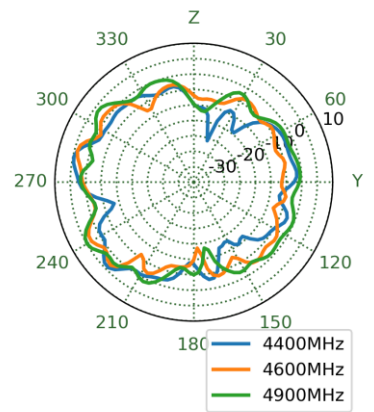
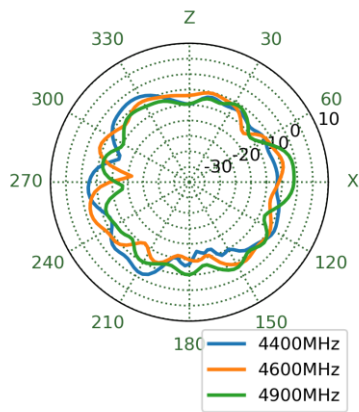
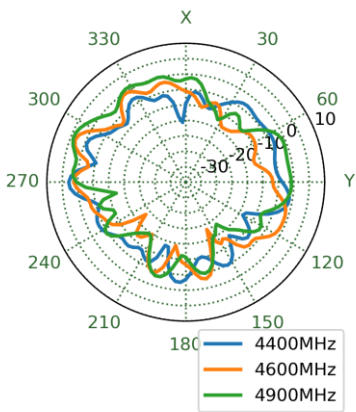

4.12 LTE 1 in Free Space Patterns at 4800 MHz

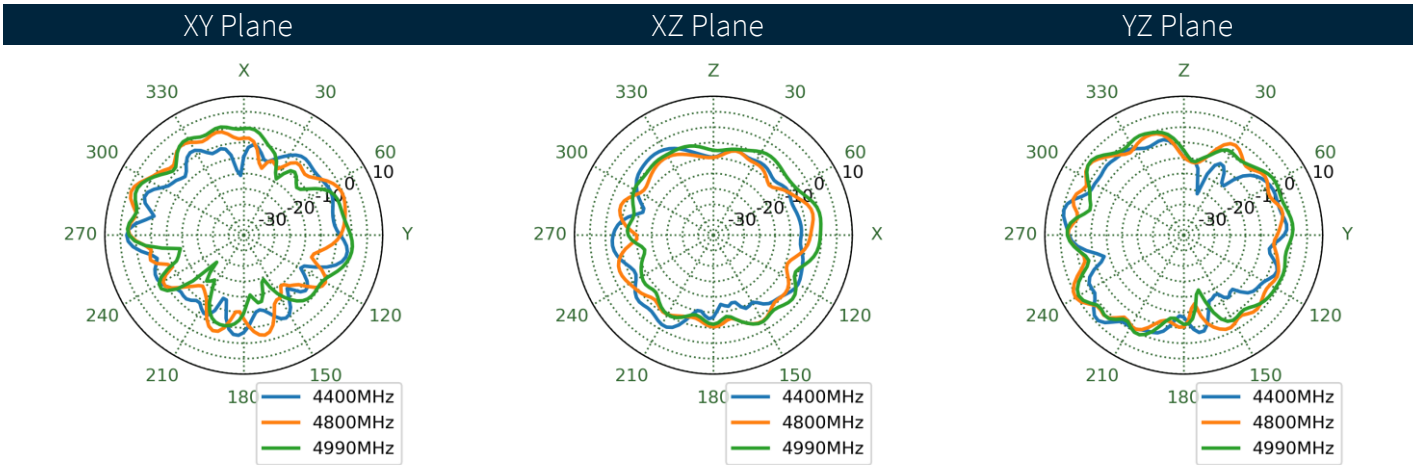
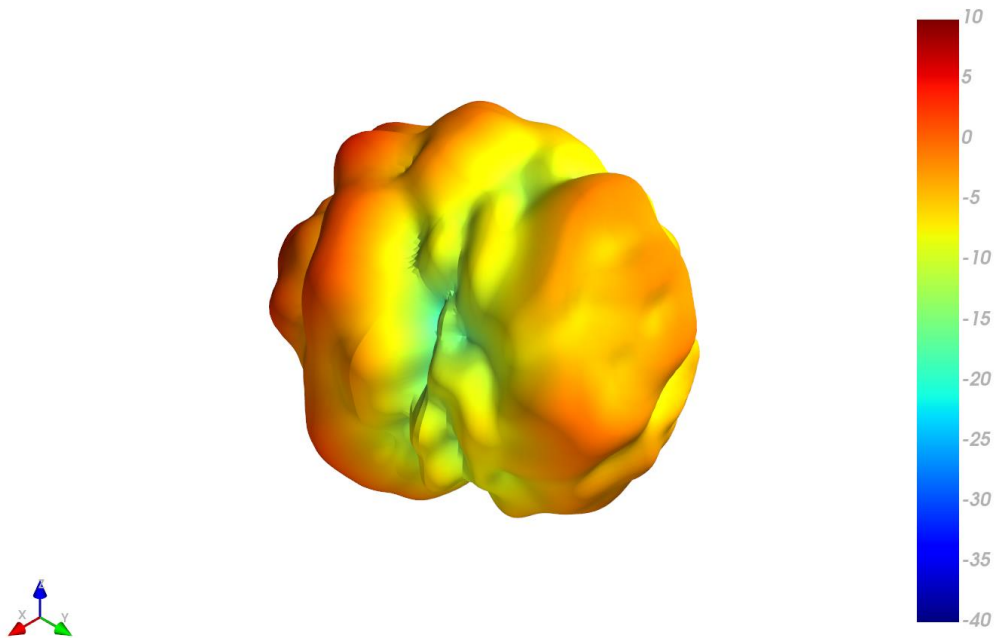

### 4.13 LTE 1 in Free Space Patterns at 5530 MHz

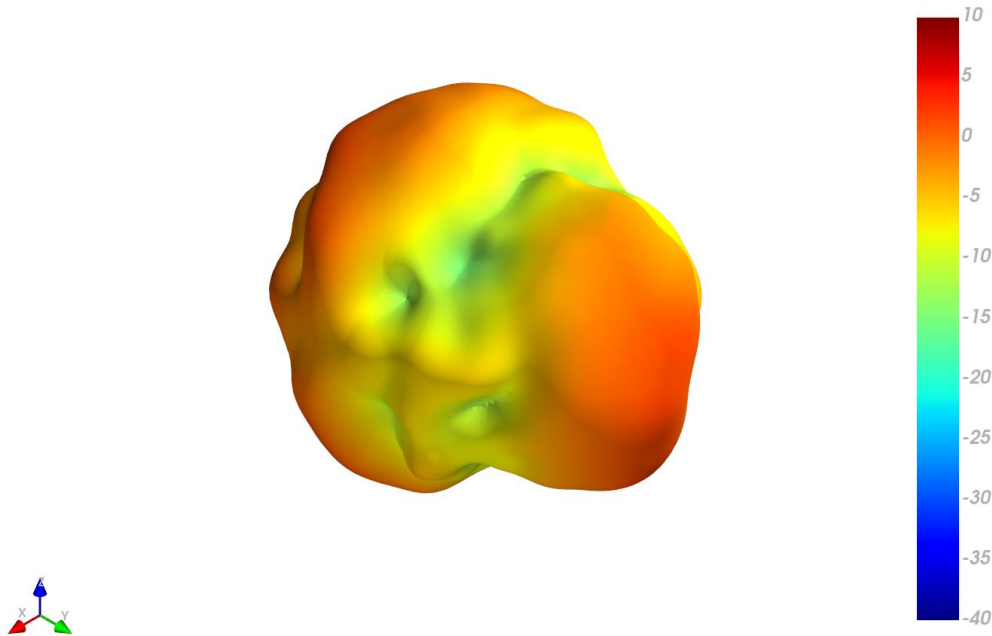

XY Plane                      XZ Plane                      YZ Plane

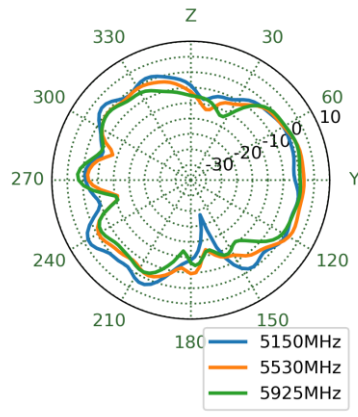
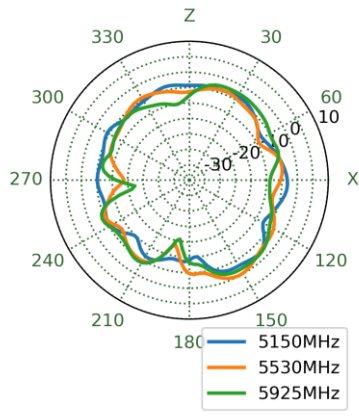
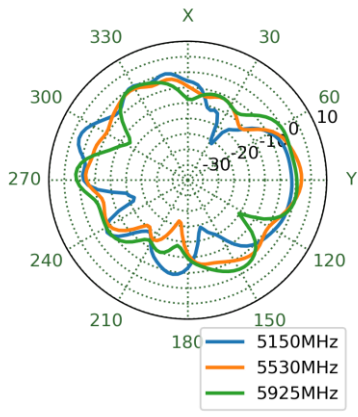

4.14 LTE 2 in Free Space Patterns at 652 MHz

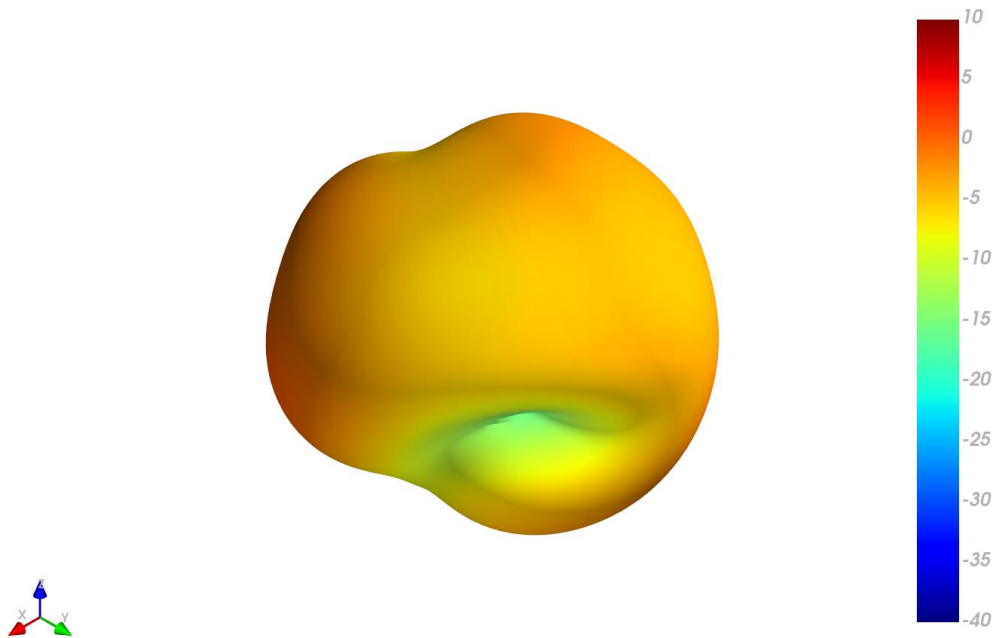

XY Plane XZ Plane YZ Plane

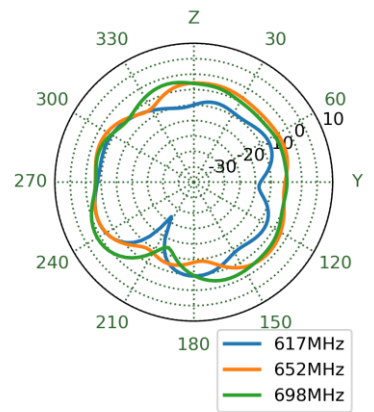
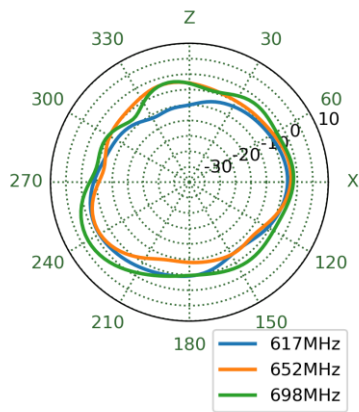
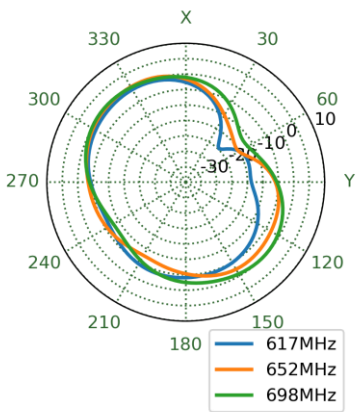

## 4.15 LTE 2 in Free Space Patterns at 751 MHz

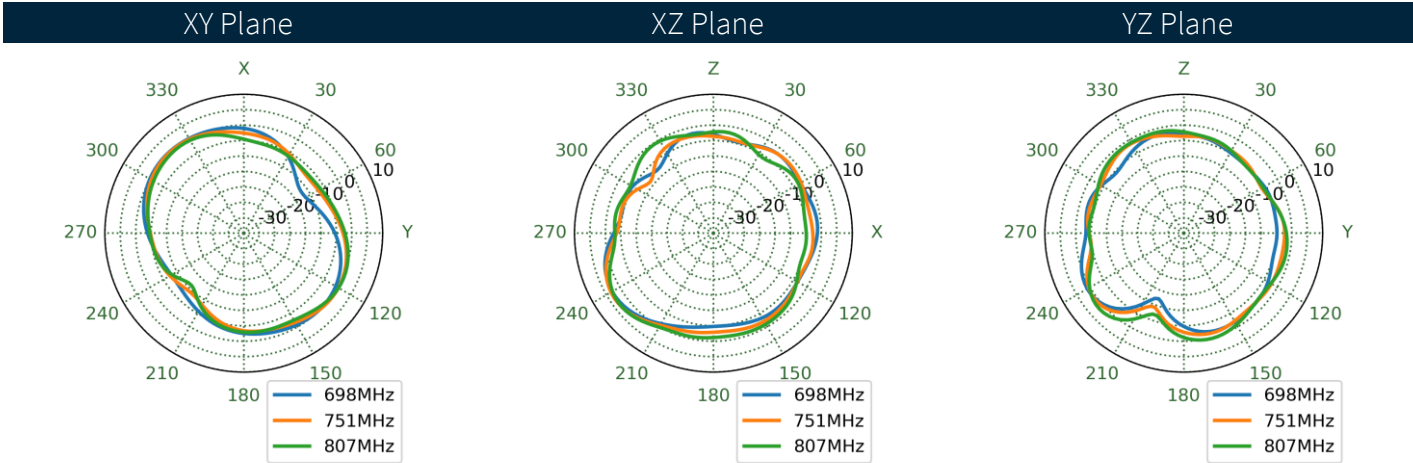
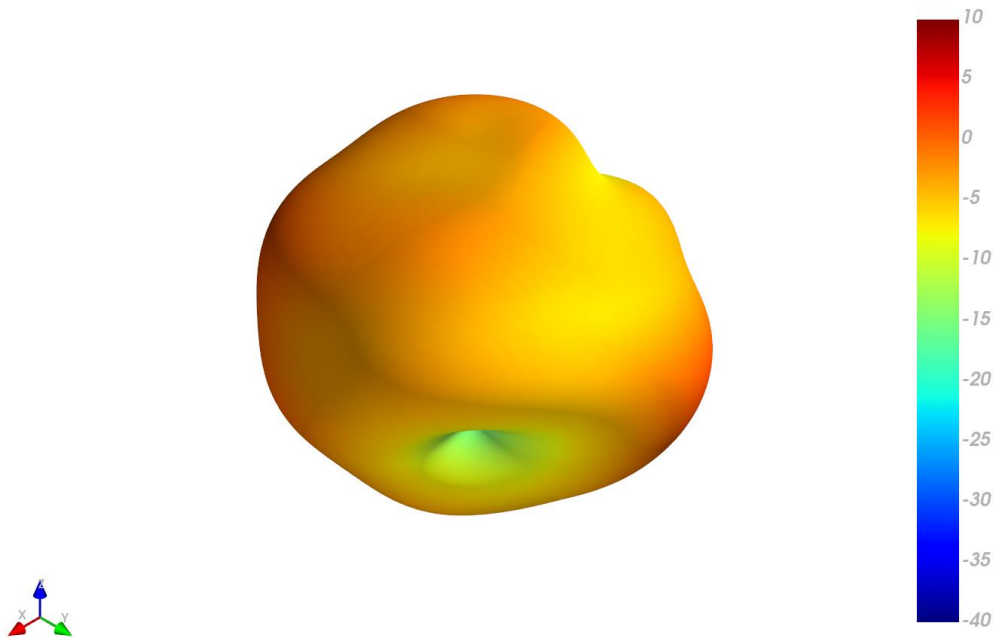



## 4.16 LTE 2 in Free Space Patterns at 890 MHz

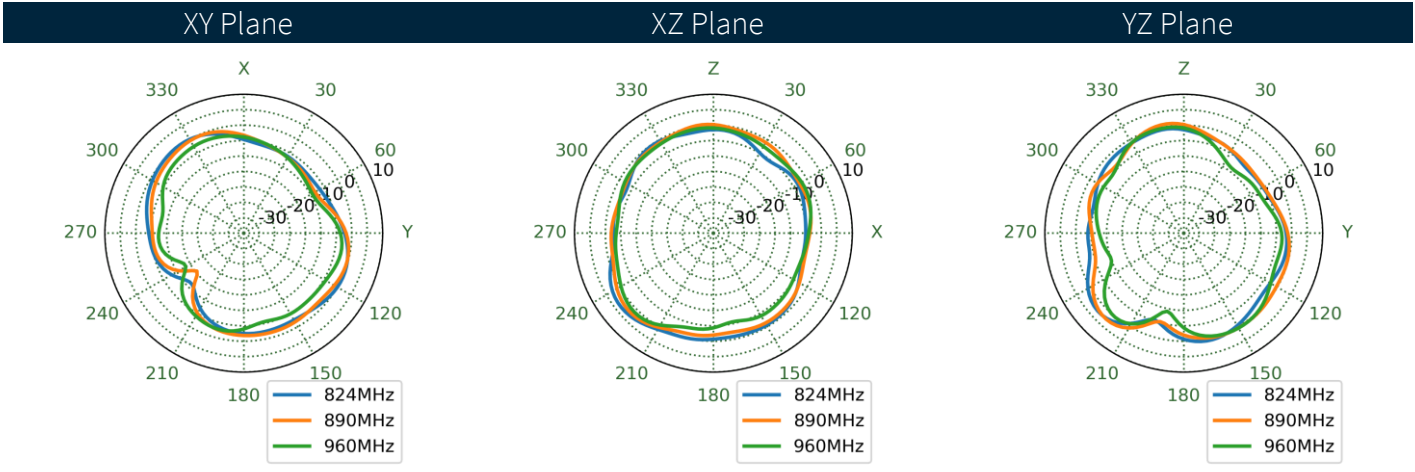
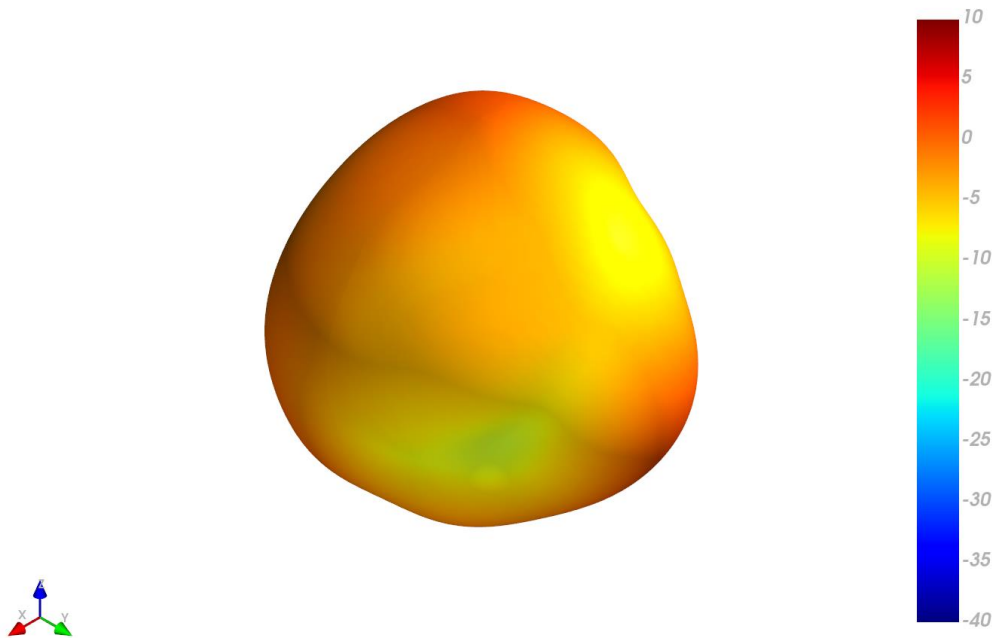

4.17 LTE 2 in Free Space Patterns at 1470 MHz

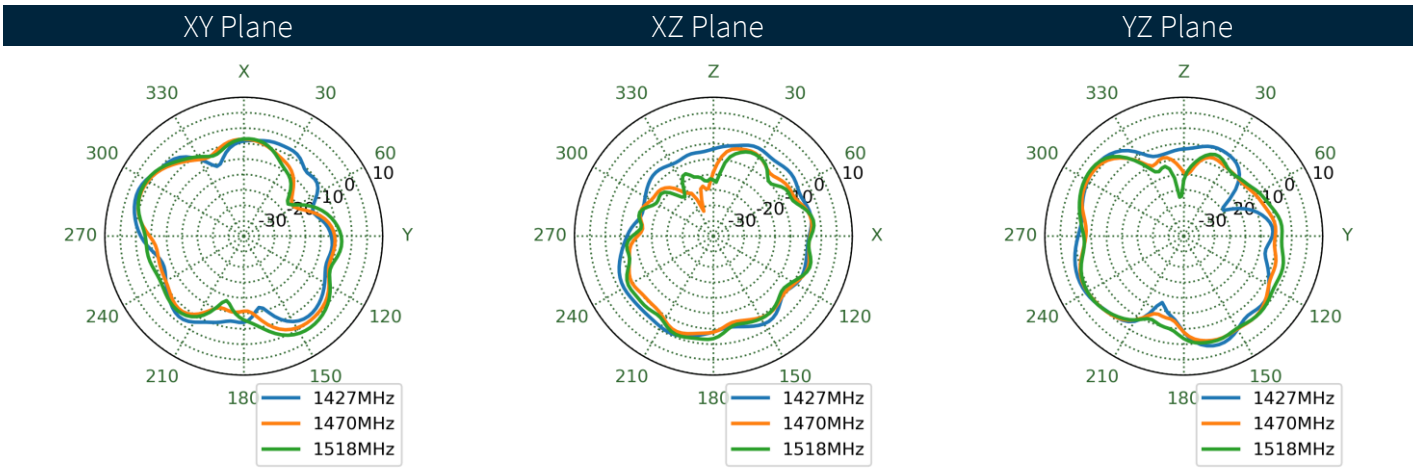
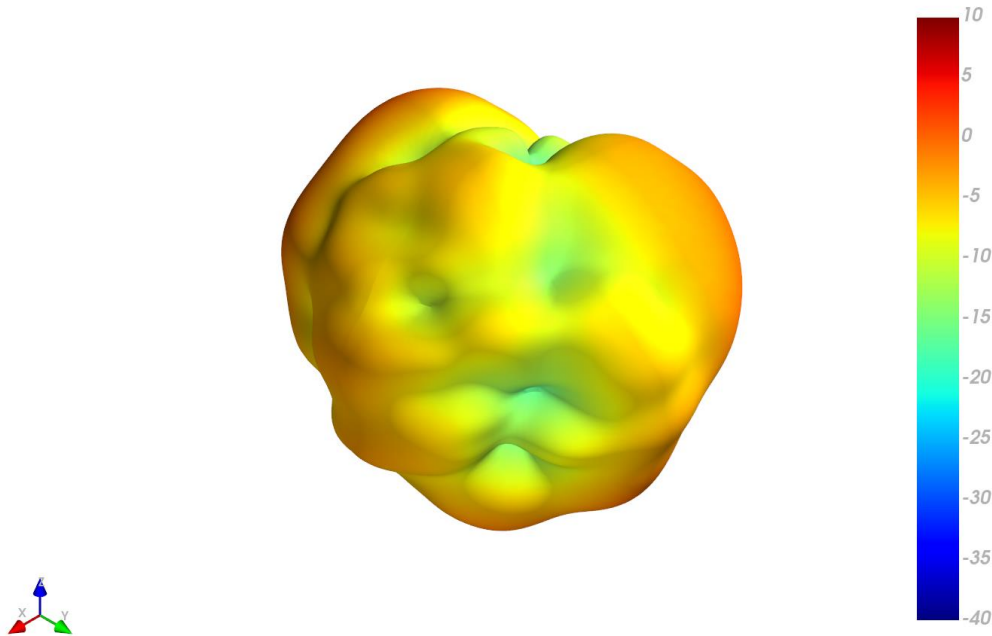

## 4.18 LTE 2 in Free Space Patterns at 1805 MHz

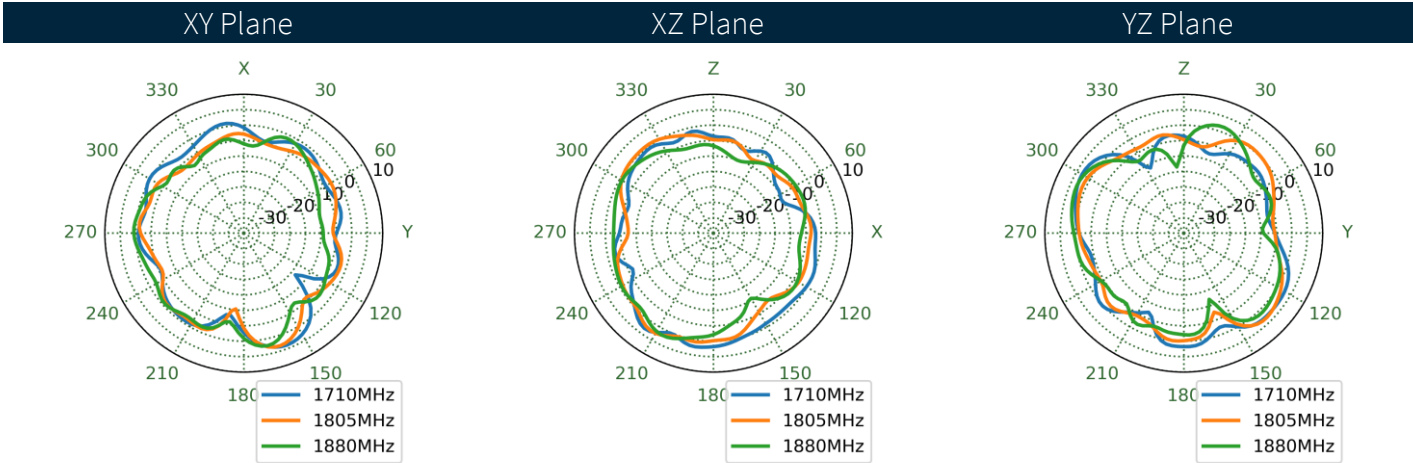
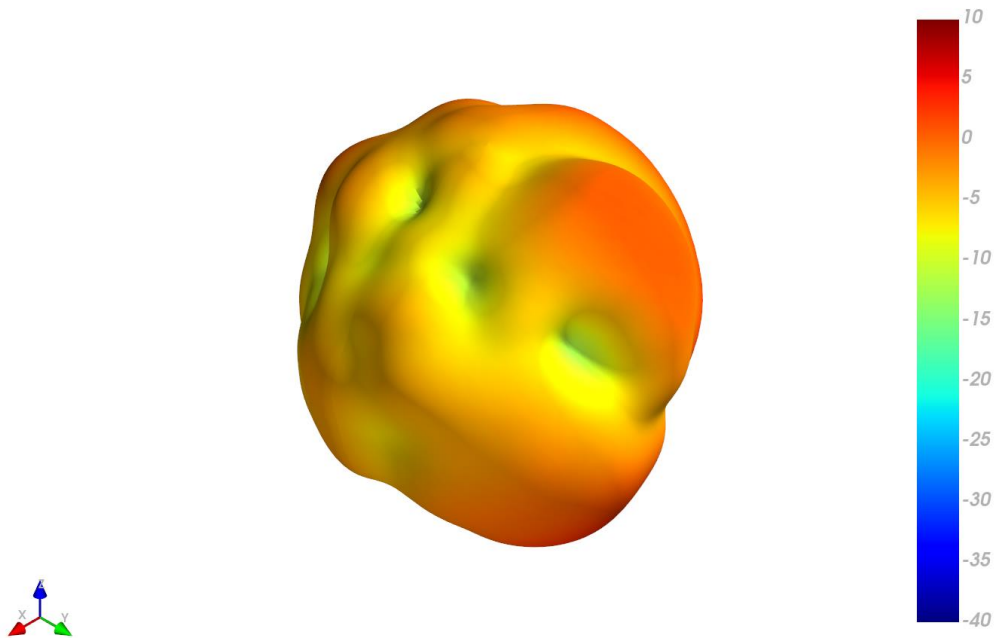

4.19 LTE 2 in Free Space Patterns at 1920 MHz

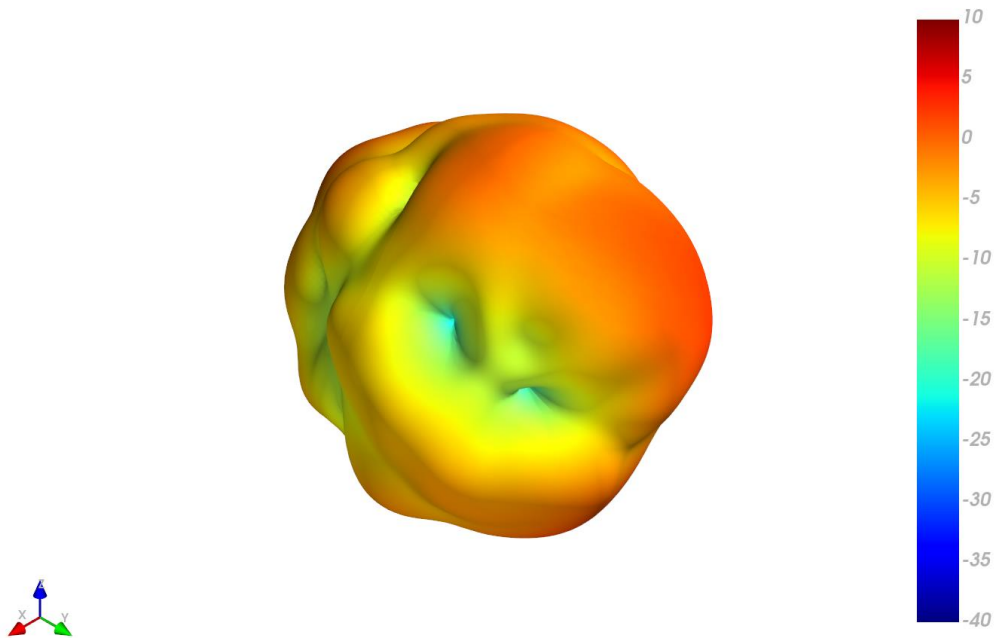

XY Plane XZ Plane YZ Plane

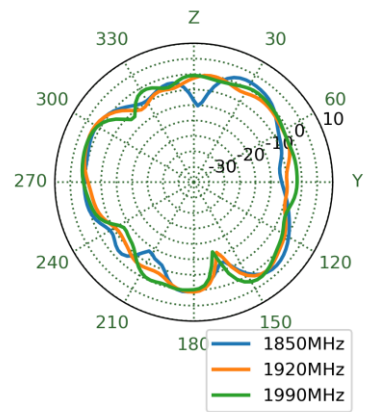
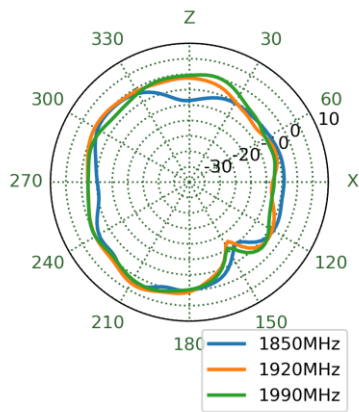
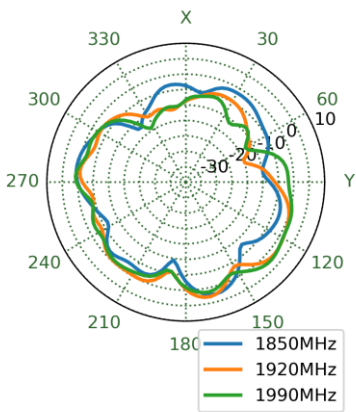

4.20 LTE 2 in Free Space Patterns at 1990 MHz

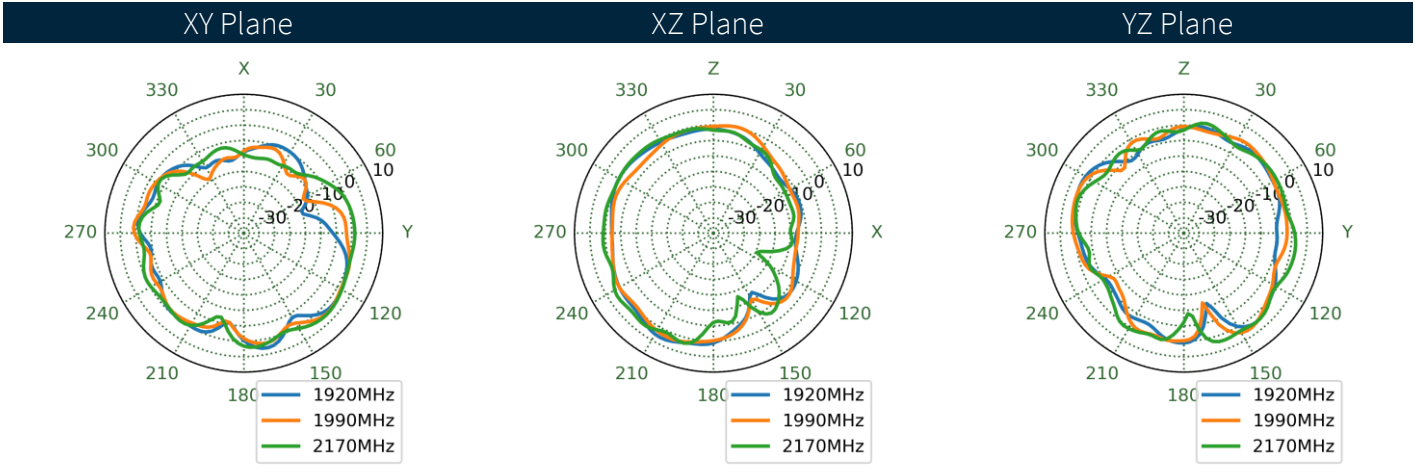
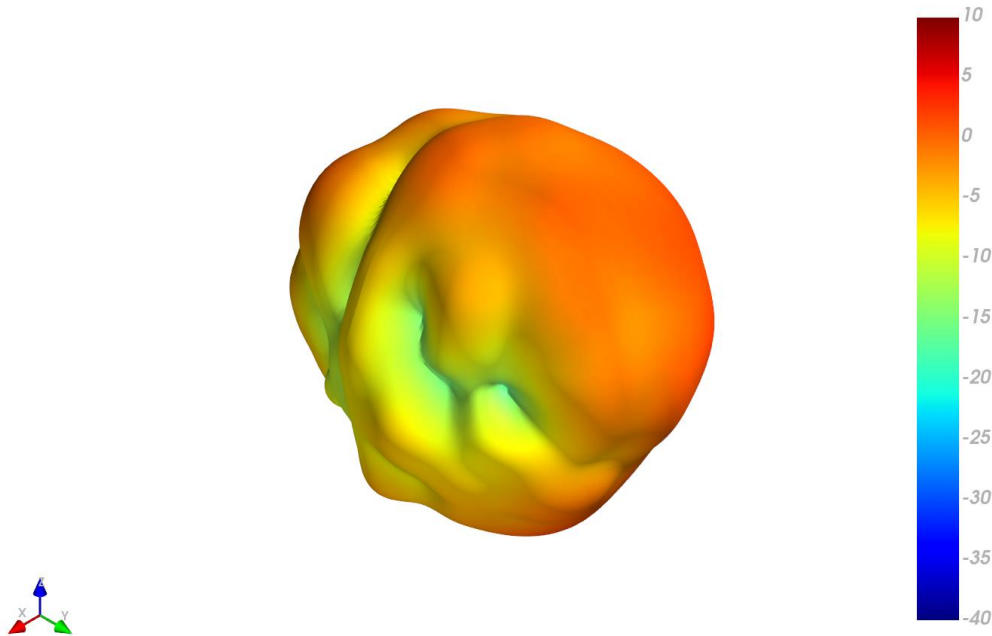

4.21 LTE 2 in Free Space Patterns at 2595 MHz

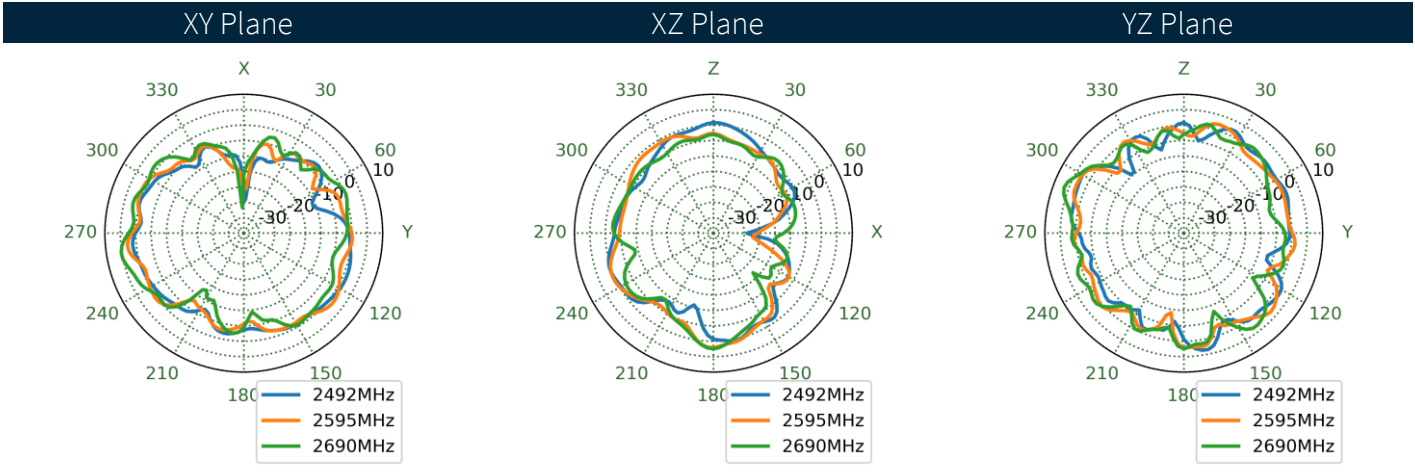
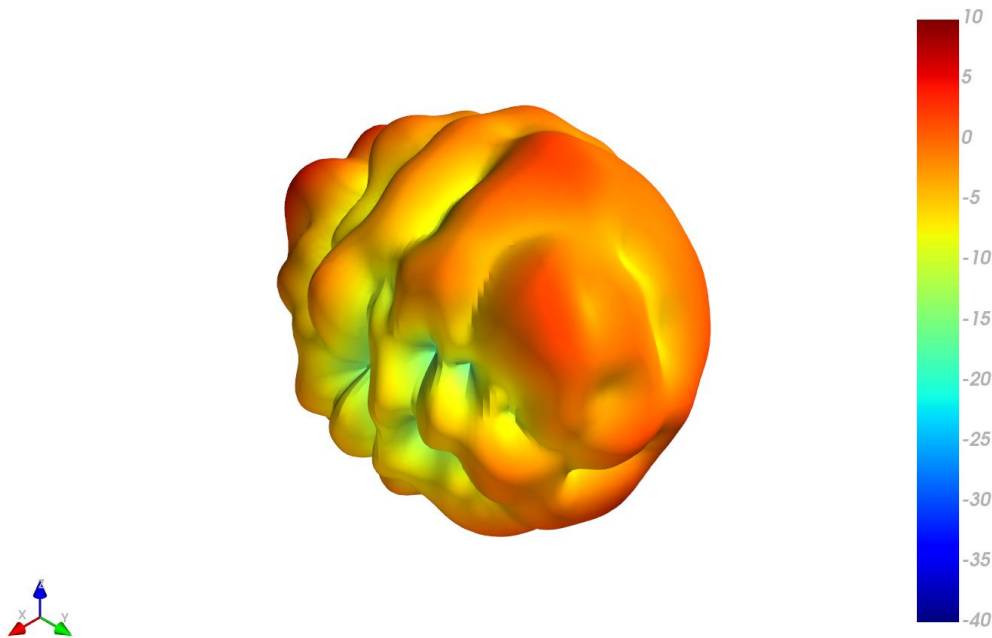

**4.22** LTE 2 in Free Space Patterns at 3550 MHz

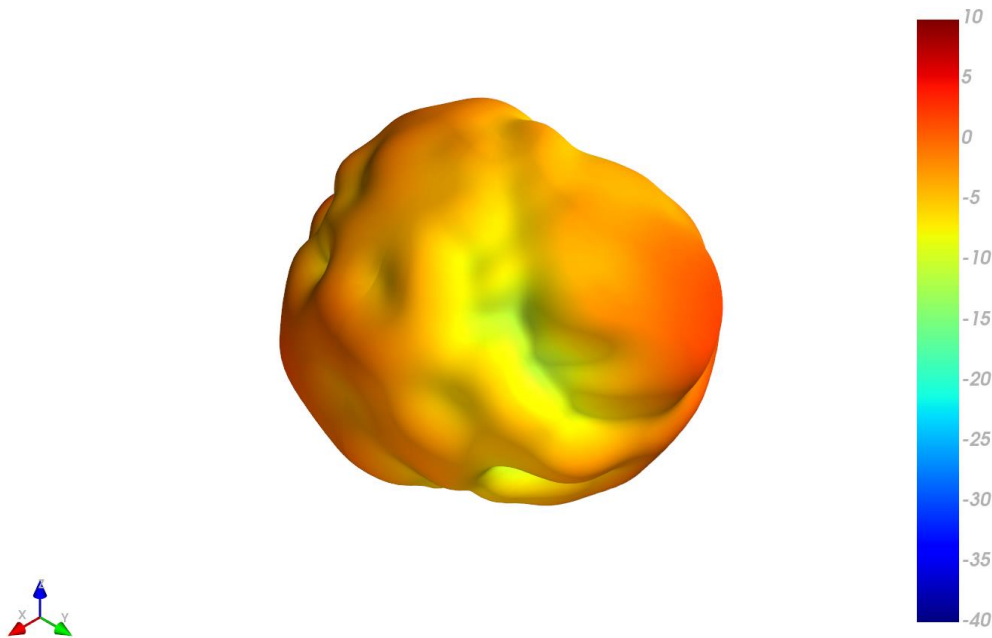

**XY Plane                      XZ Plane                      YZ Plane**

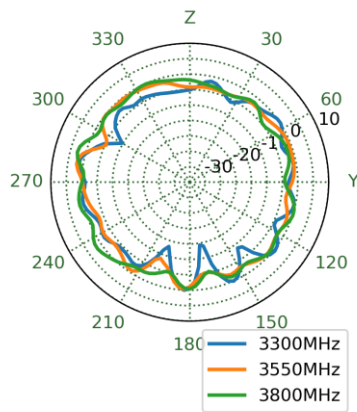
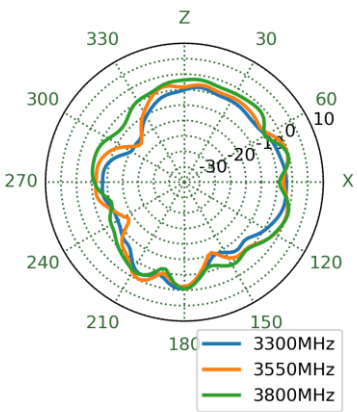
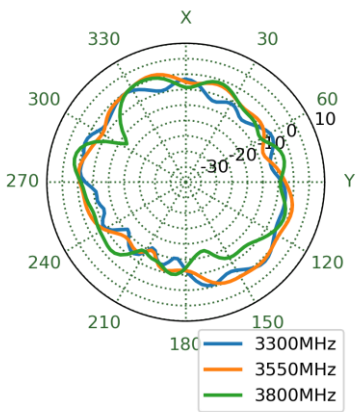

4.23 LTE 2 in Free Space Patterns at 4800 MHz

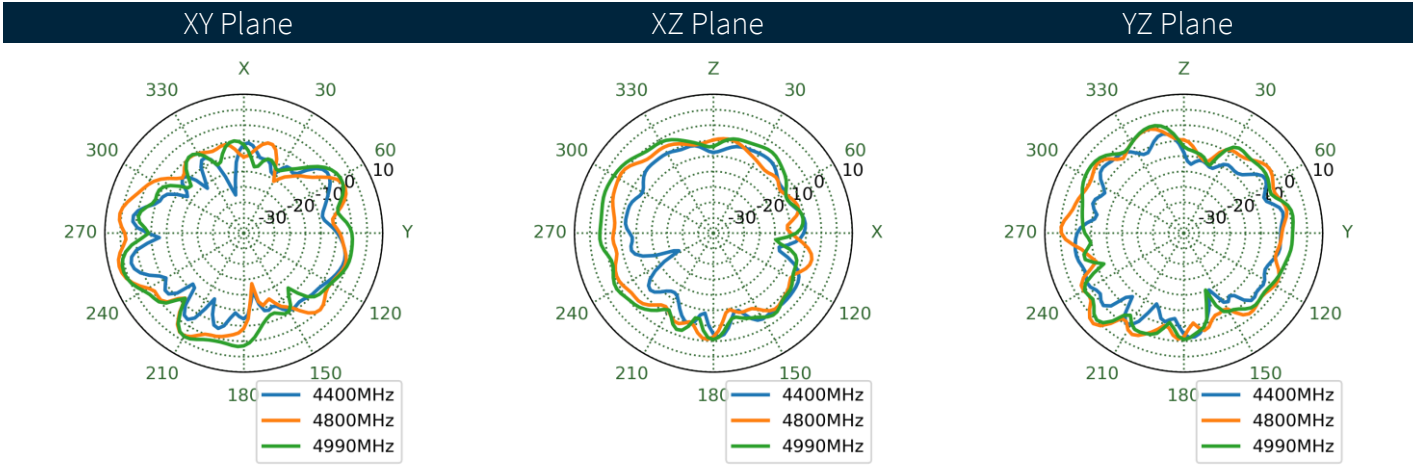
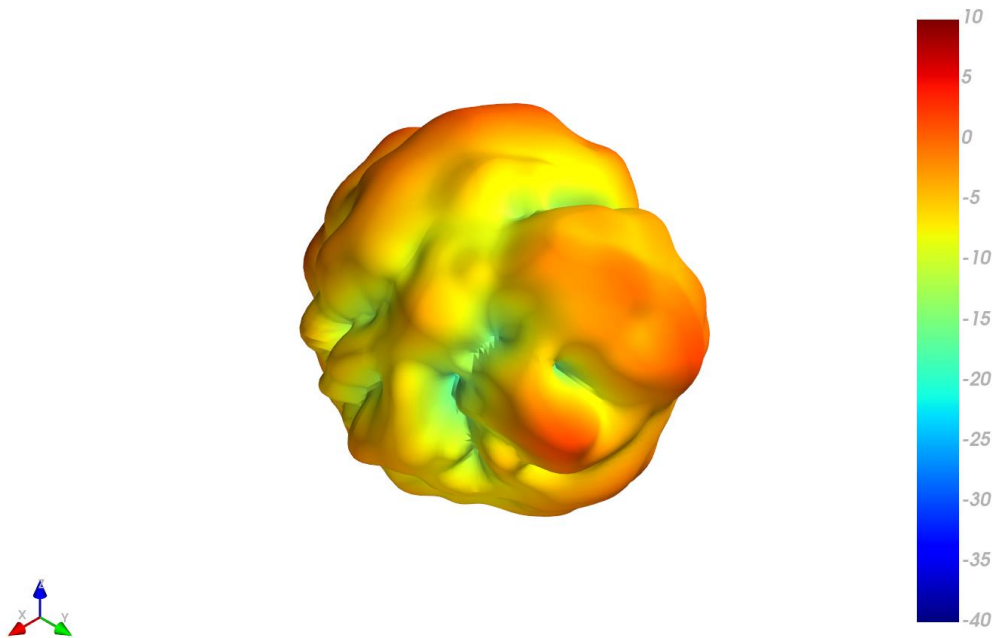



4.24 LTE 2 in Free Space Patterns at 5530 MHz

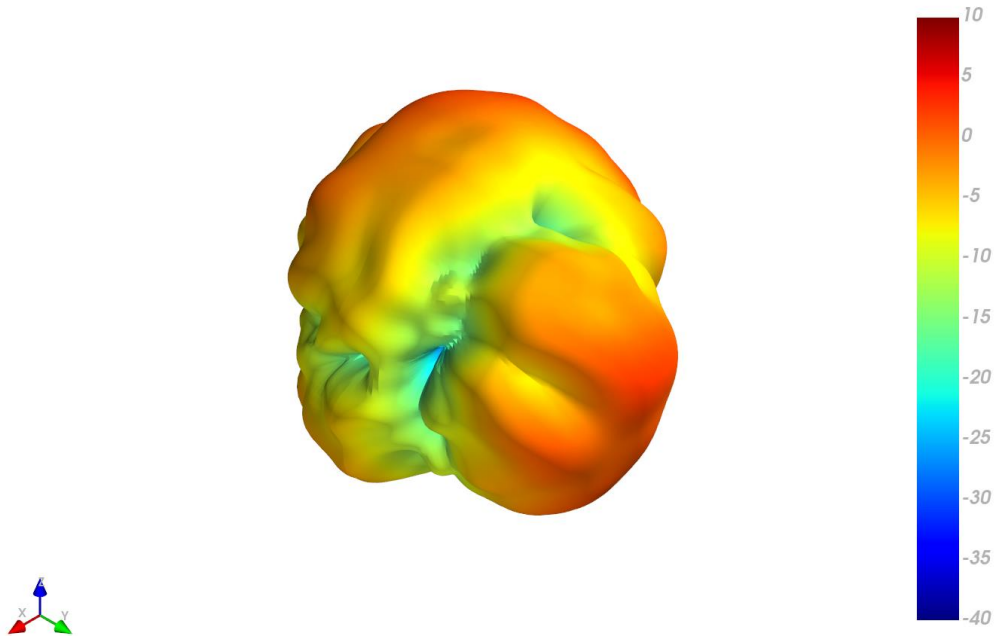

XY Plane                      XZ Plane                      YZ Plane

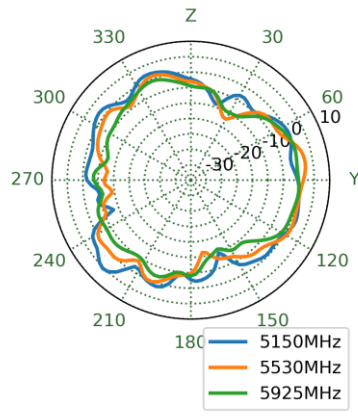
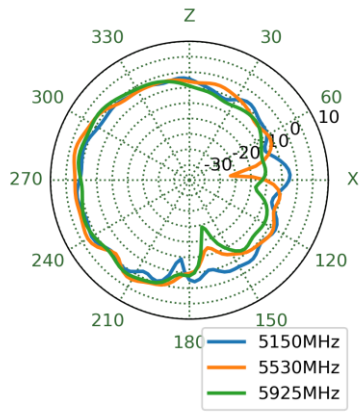
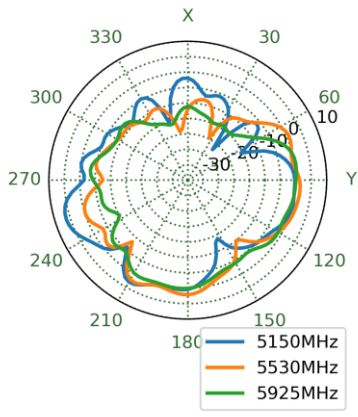

4.25 LTE 1 on 30x30cm Ground Plane Patterns at 652 MHz

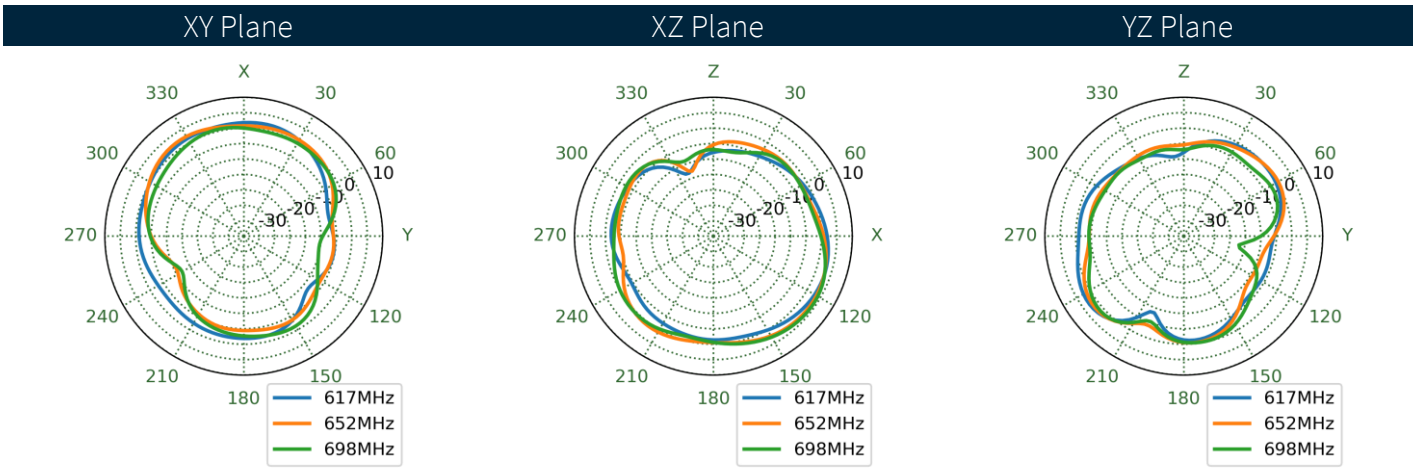
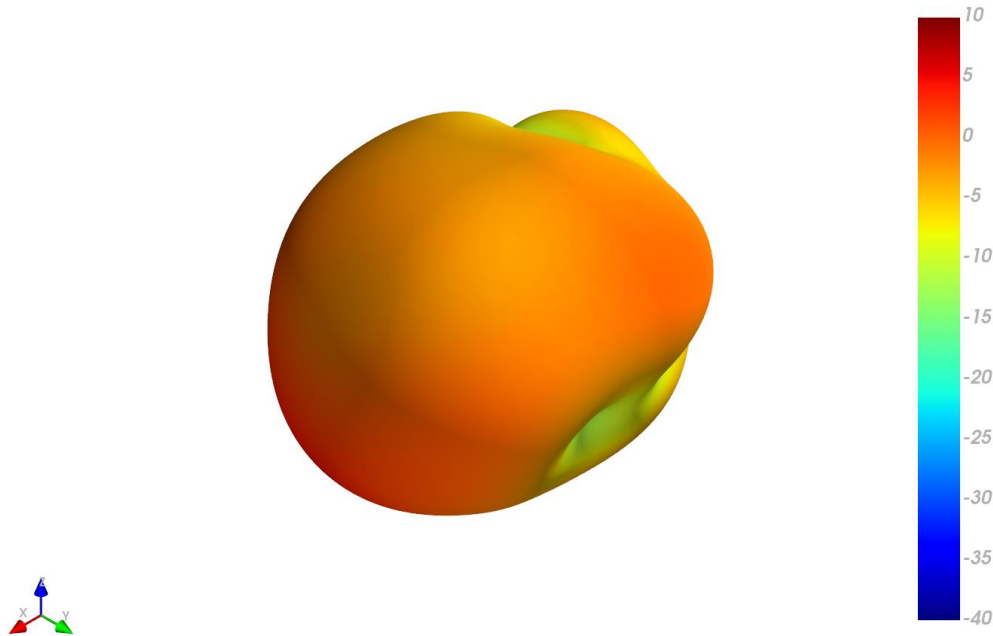

4.26 LTE 1 on 30x30cm Ground Plane Patterns at 751 MHz

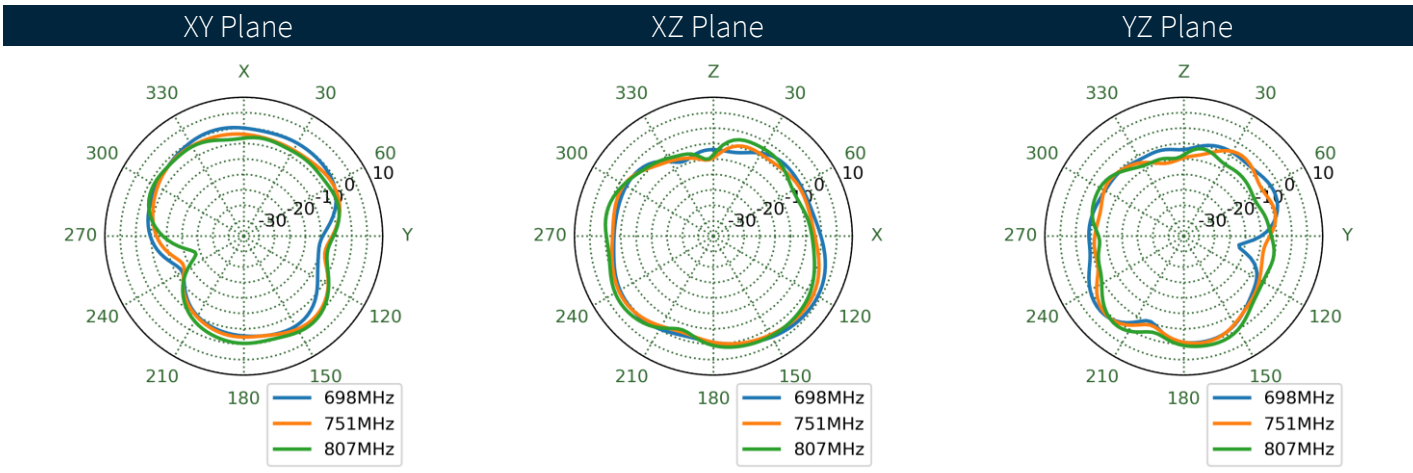
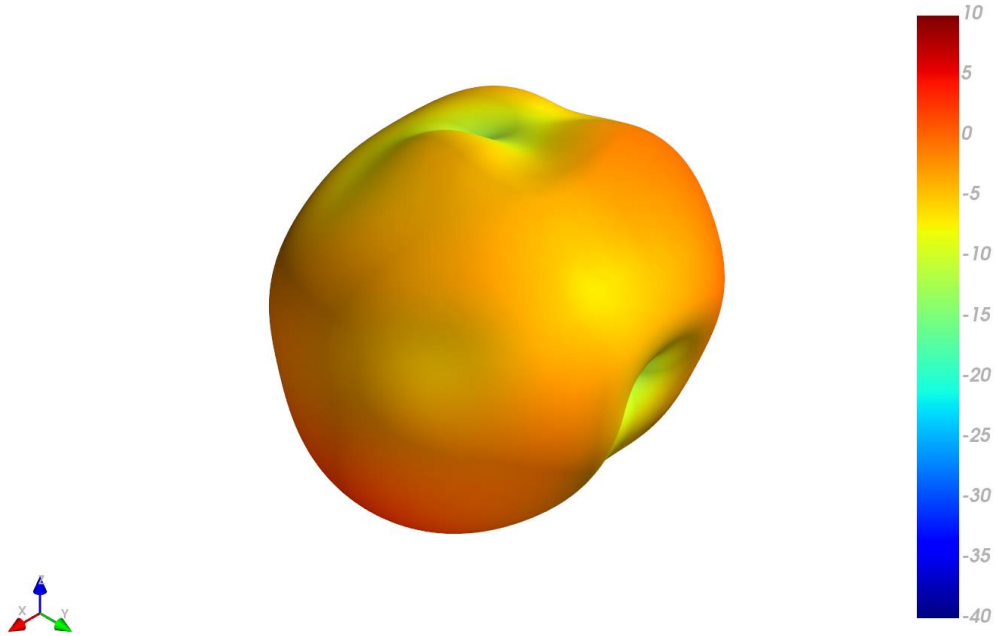

**4.27** LTE 1 on 30x30cm Ground Plane Patterns at 890 MHz

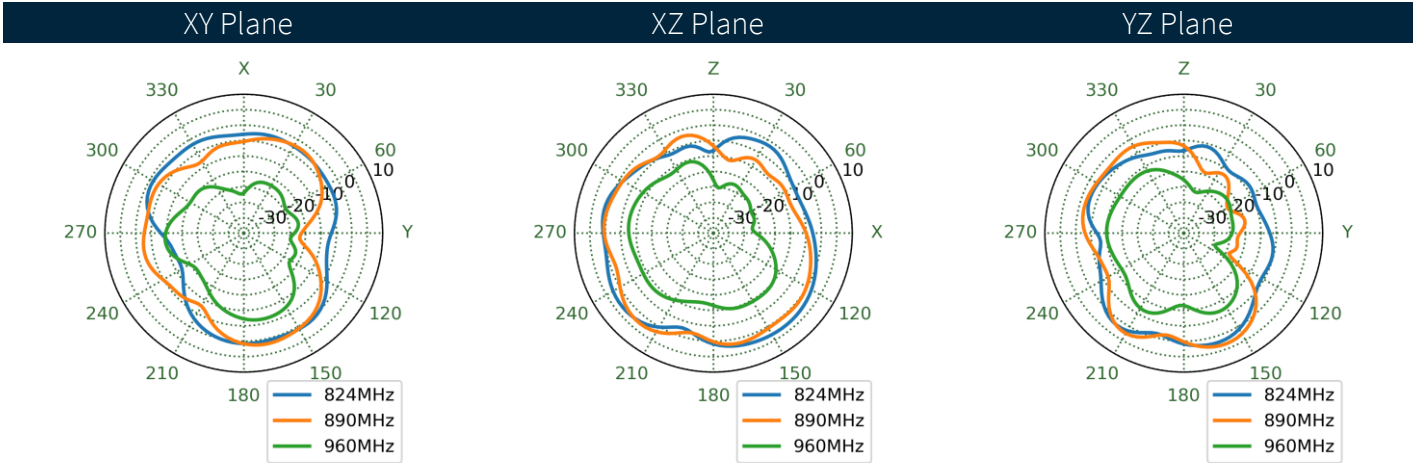
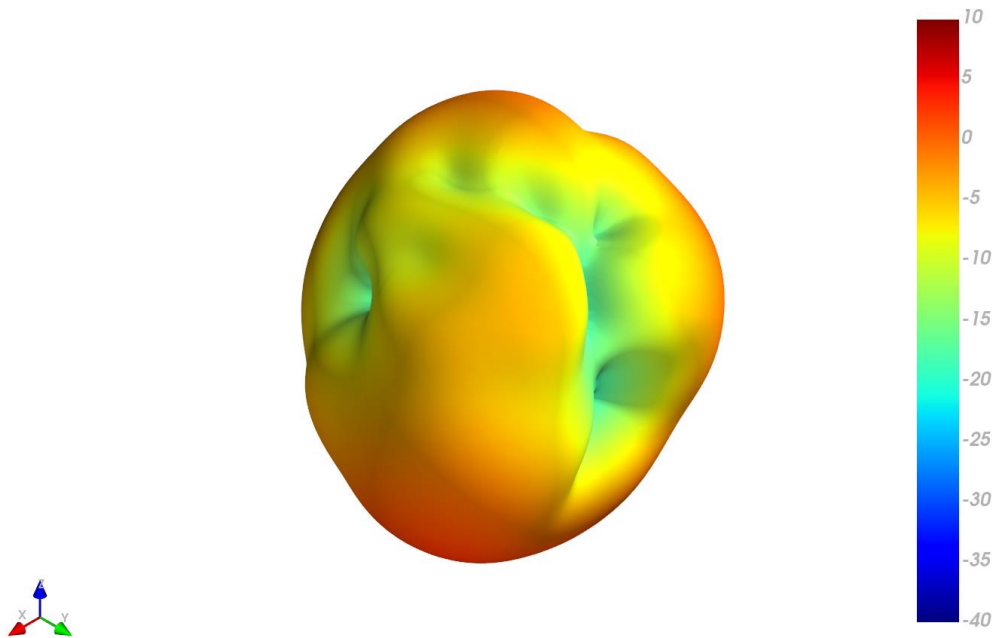

**4.28** LTE 1 on 30x30cm Ground Plane Patterns at 1470 MHz

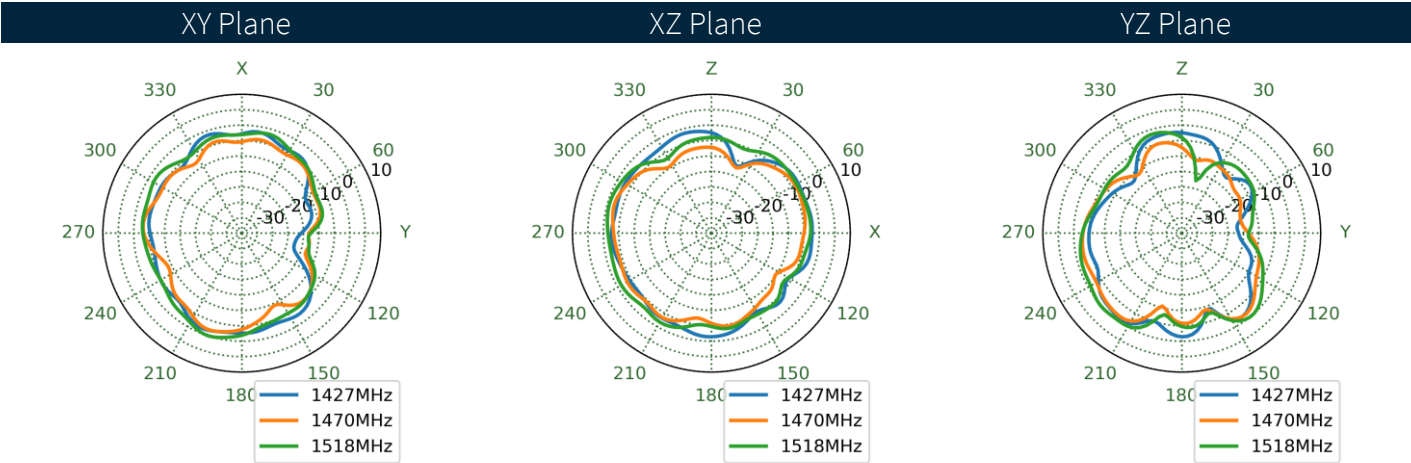
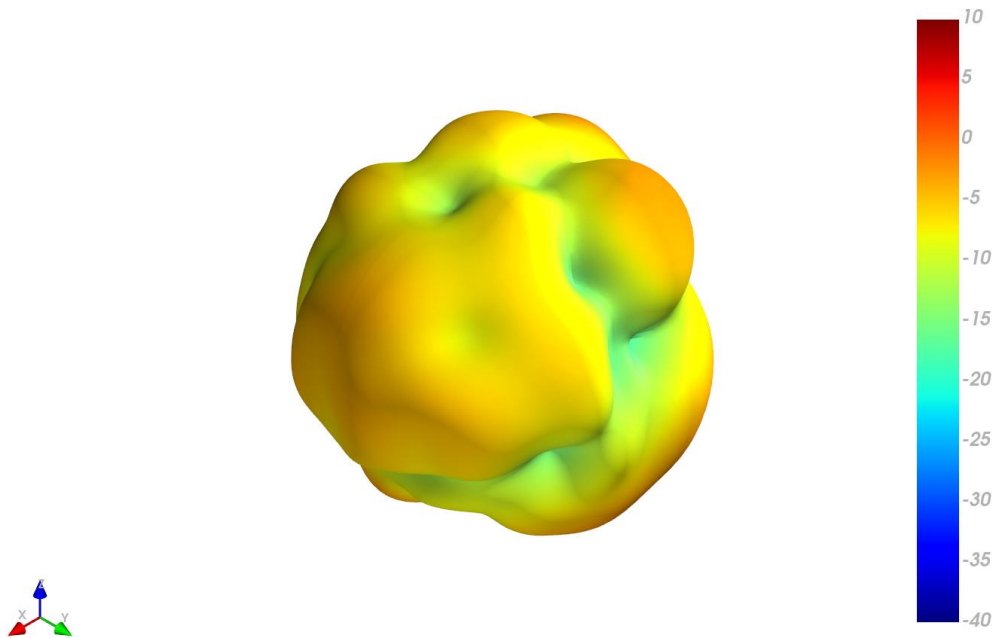

4.29 LTE 1 on 30x30cm Ground Plane Patterns at 1805 MHz

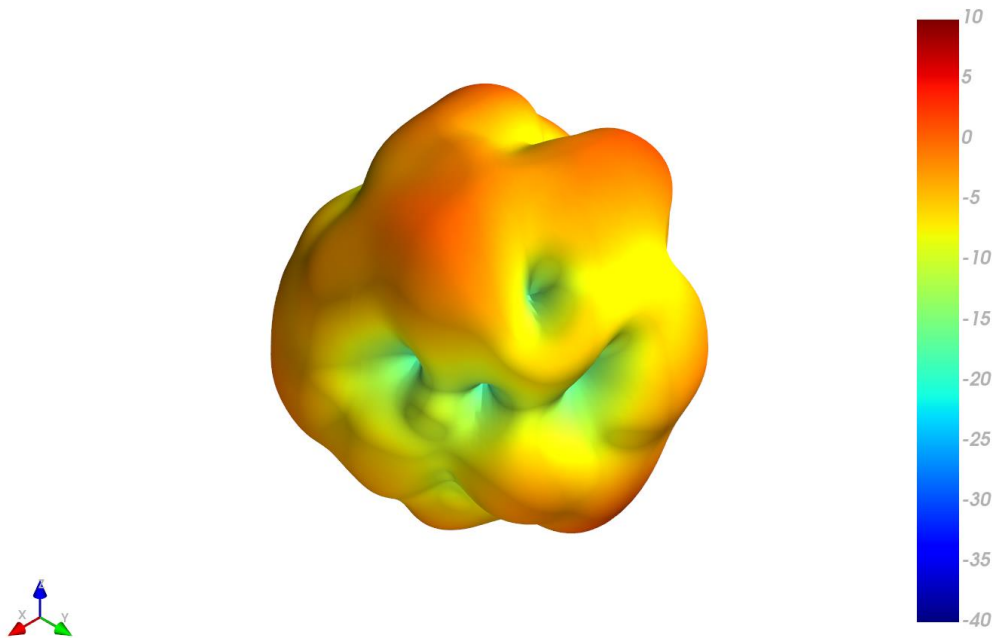

XY Plane XZ Plane YZ Plane

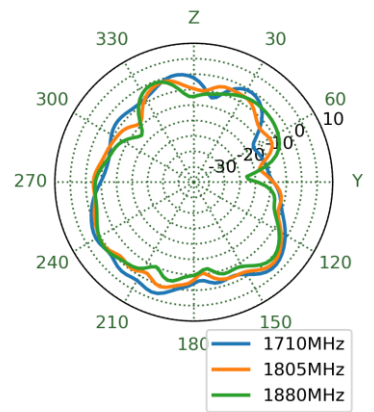
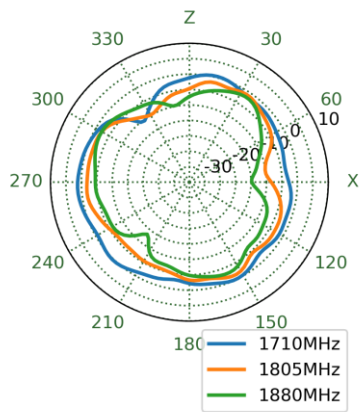
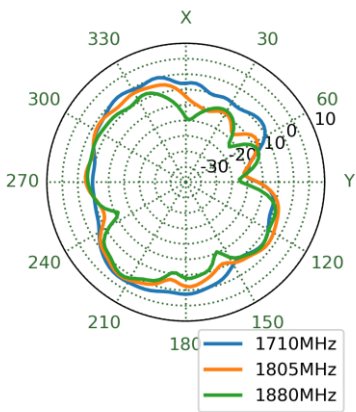

4.30 LTE 1 on 30x30cm Ground Plane Patterns at 1920 MHz

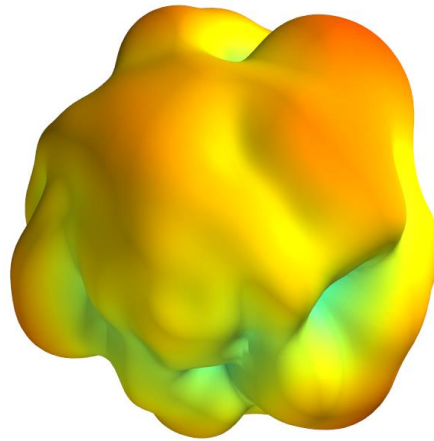

XY Plane XZ Plane YZ Plane

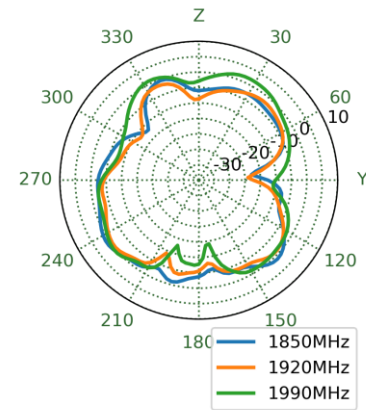
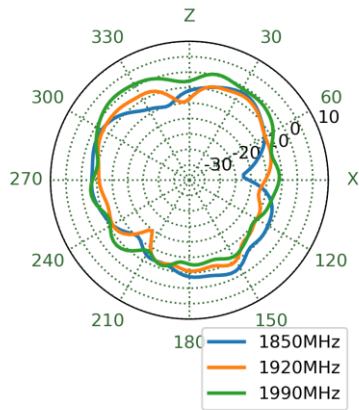
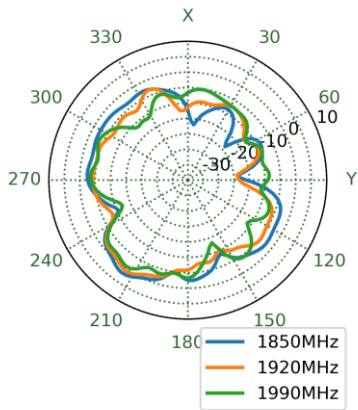

4.31 LTE 1 on 30x30cm Ground Plane Patterns at 1990 MHz

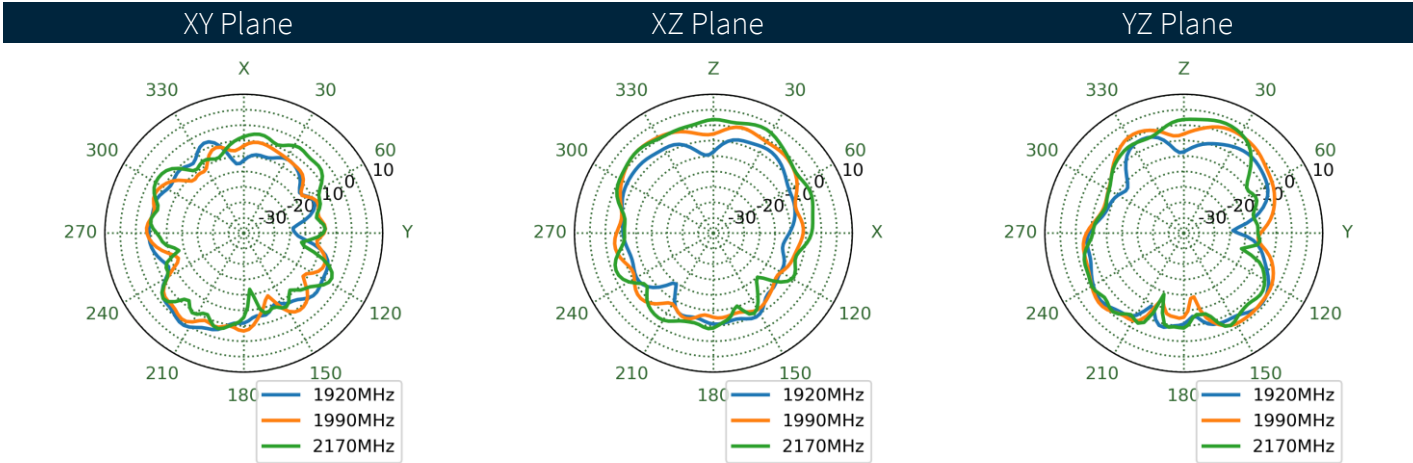
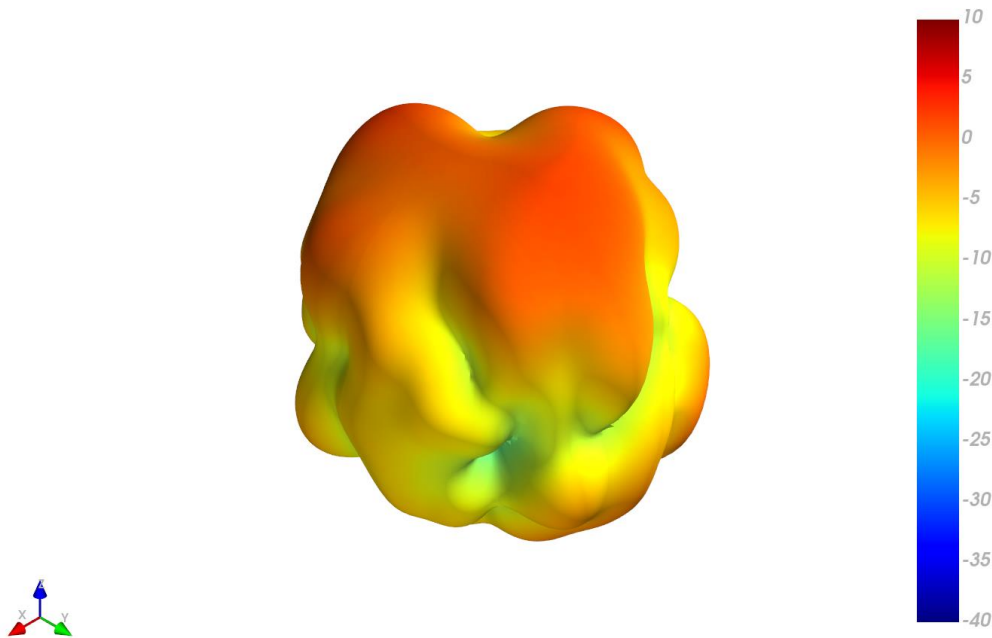



**4.32** LTE 1 on 30x30cm Ground Plane Patterns at 2595 MHz

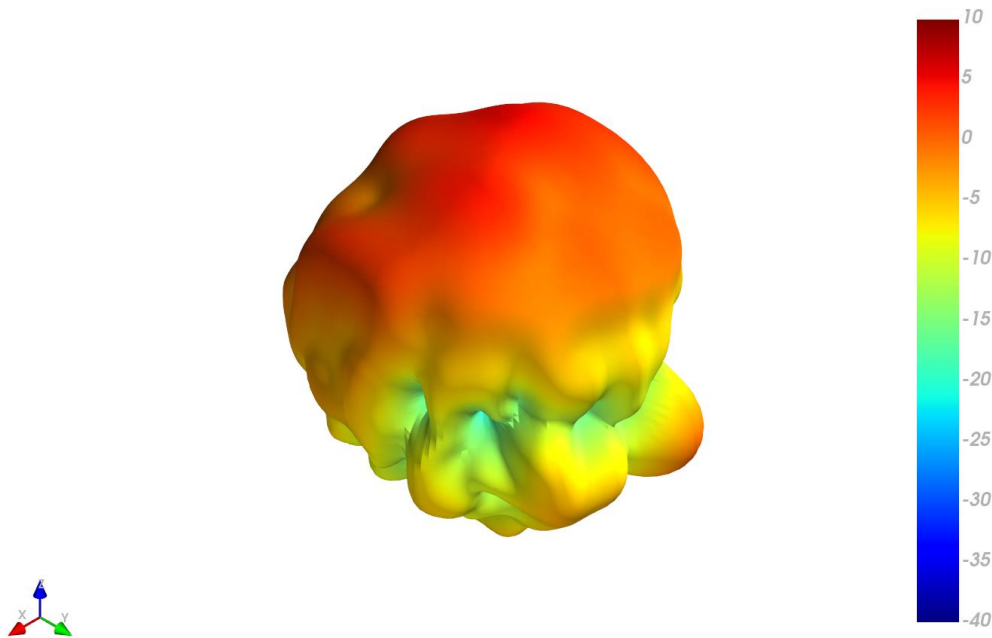

**XY Plane                      XZ Plane                      YZ Plane**

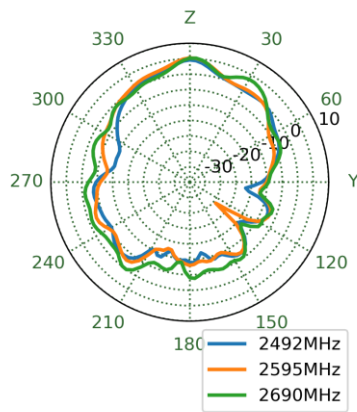
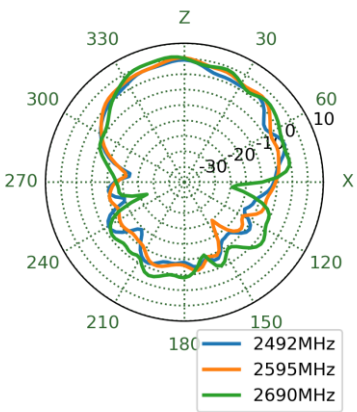
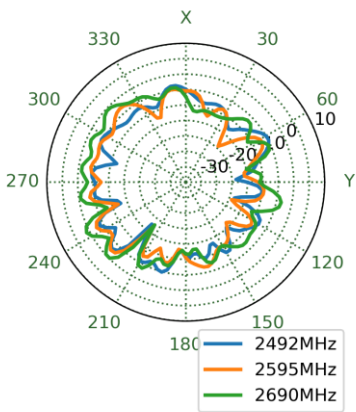

4.33 LTE 1 on 30x30cm Ground Plane Patterns at 3550 MHz

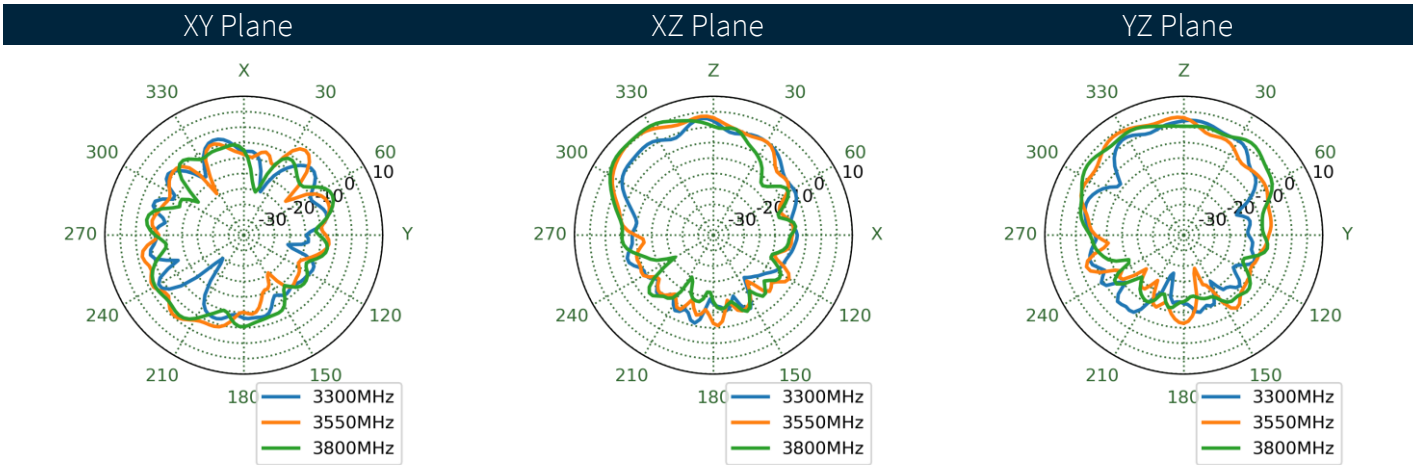
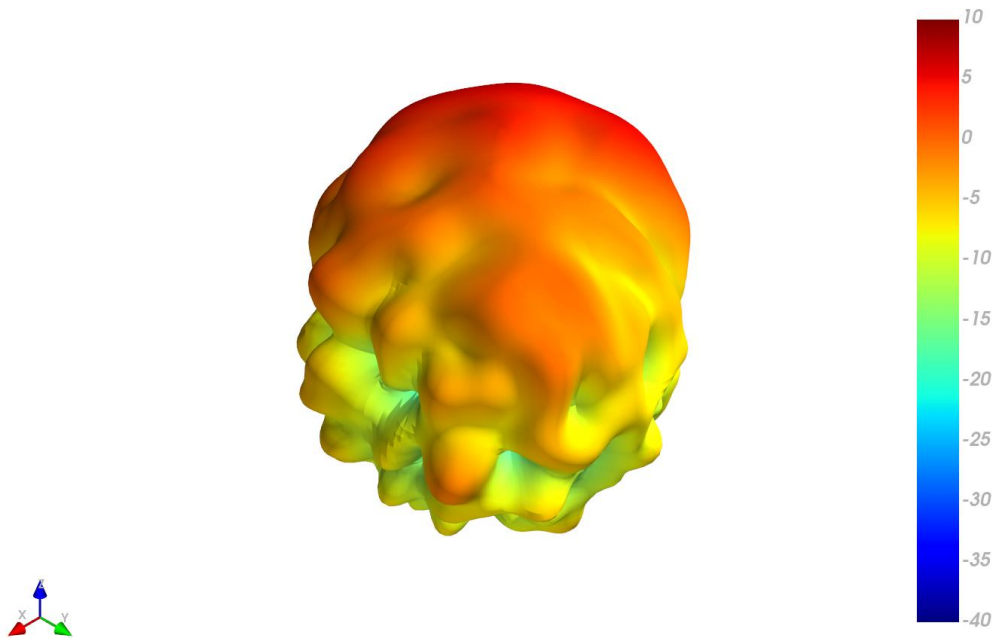

4.34 LTE 1 on 30x30cm Ground Plane Patterns at 4600 MHz

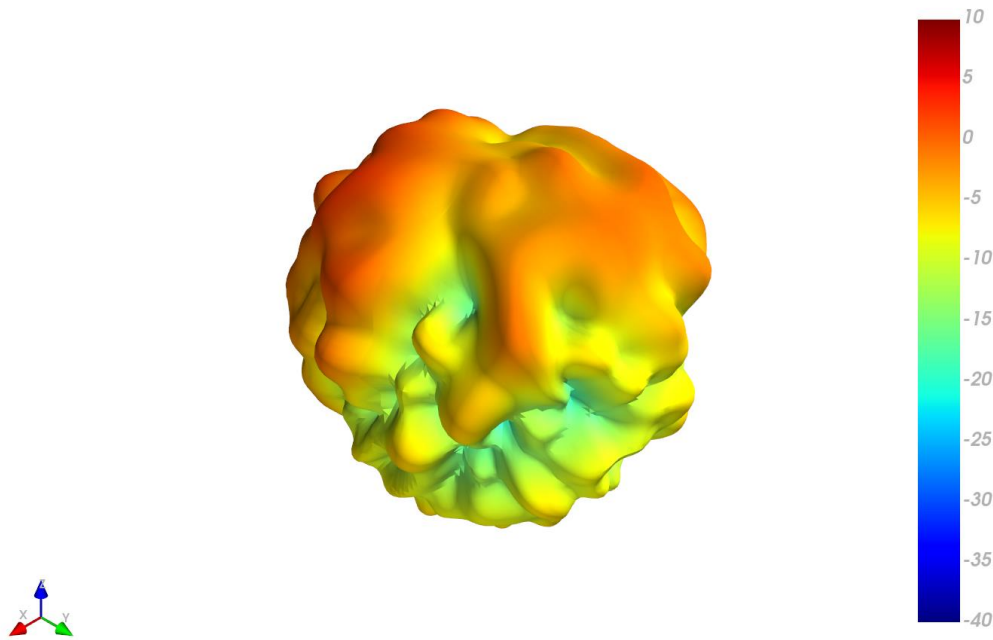

XY Plane XZ Plane YZ Plane

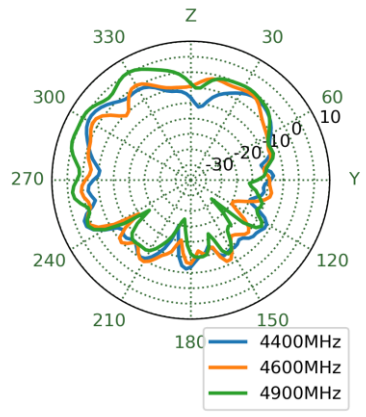
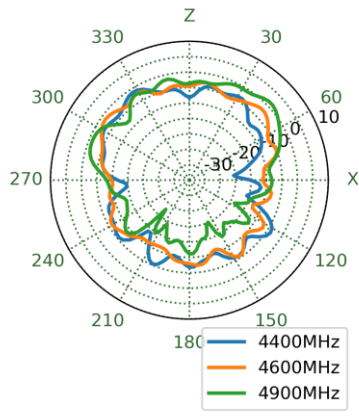
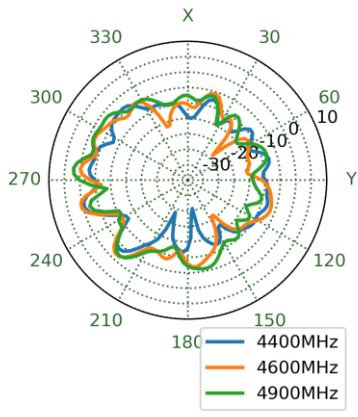

4.35 LTE 1 on 30x30cm Ground Plane Patterns at 4800 MHz

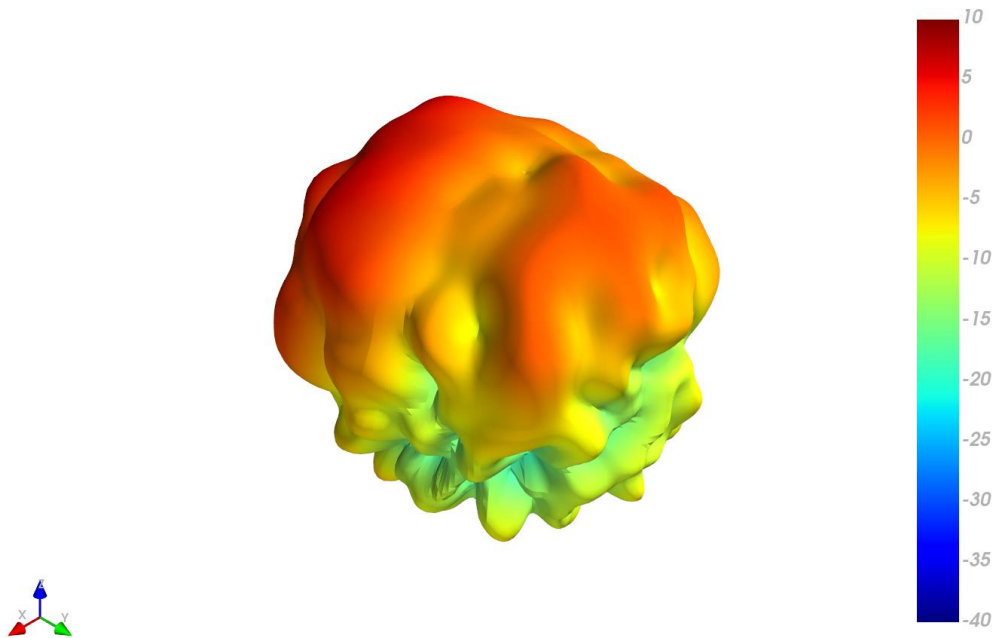

XY Plane XZ Plane YZ Plane

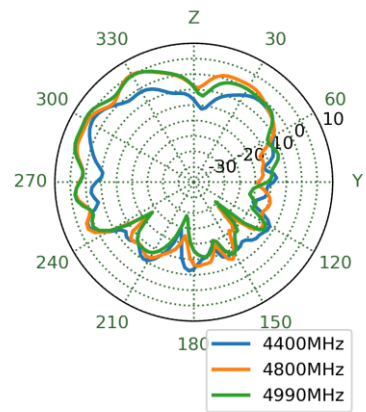
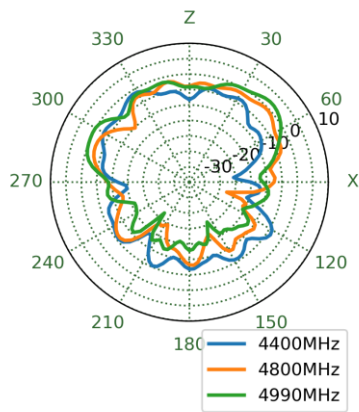
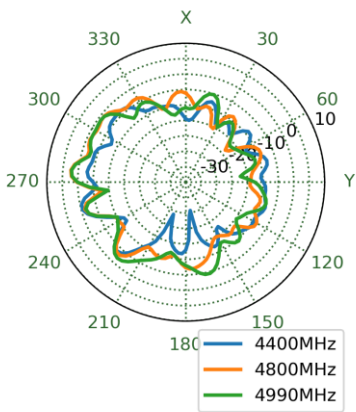

4.36 LTE 1 on 30x30cm Ground Plane Patterns at 5530 MHz

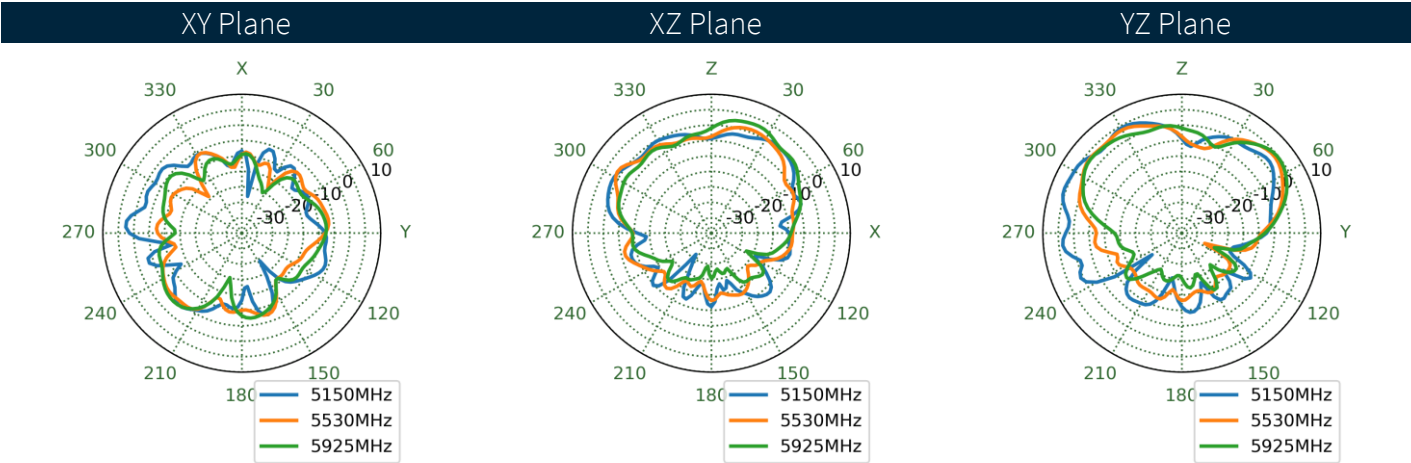
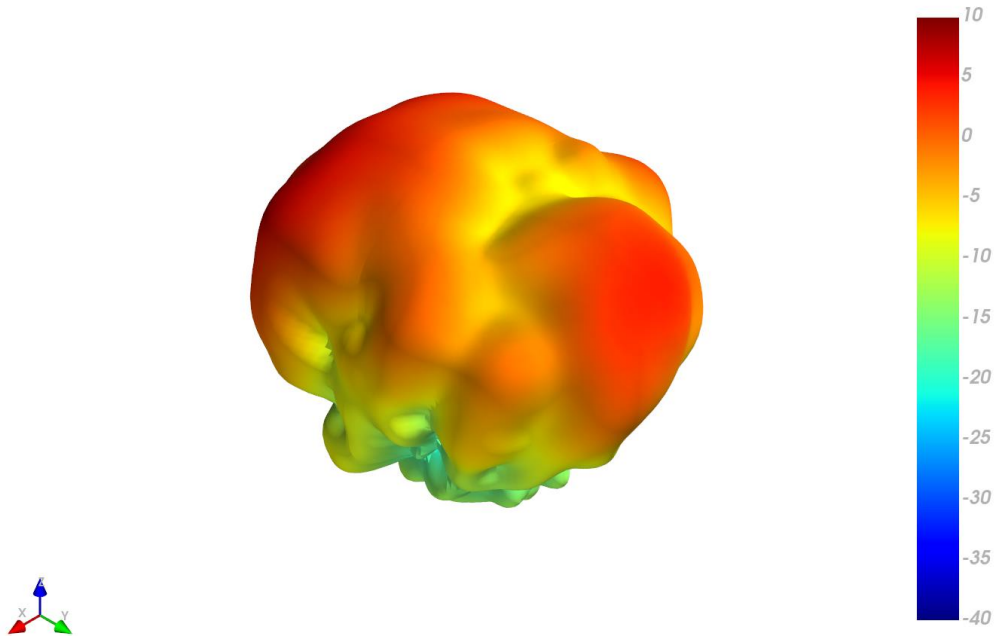

4.37 LTE 2 on 30x30cm Ground Plane Patterns at 652 MHz

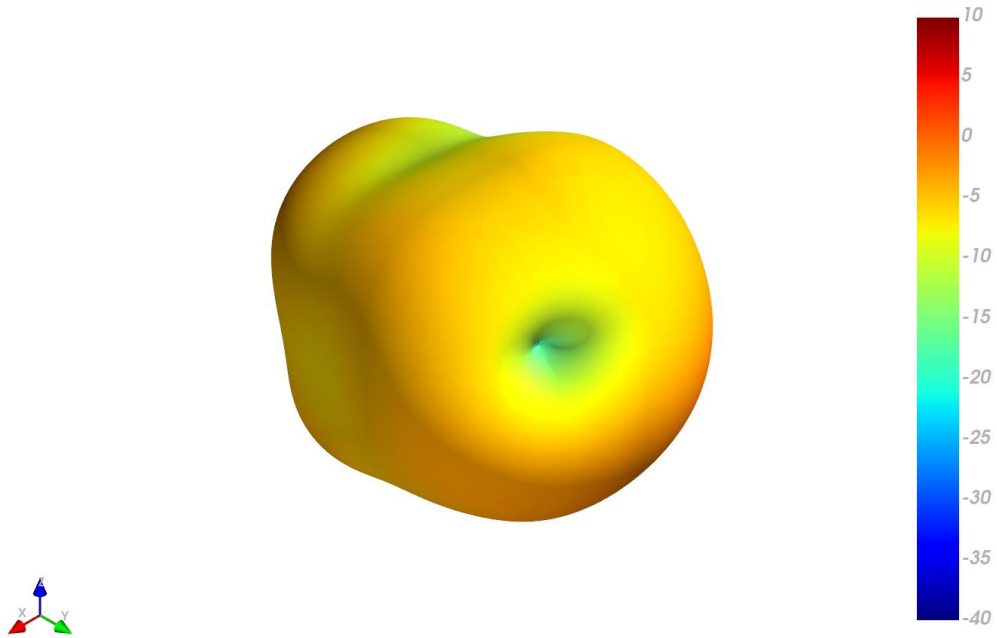

XY Plane XZ Plane YZ Plane

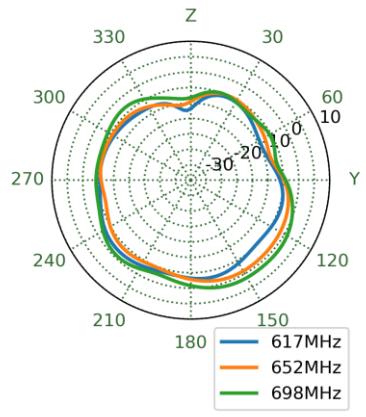
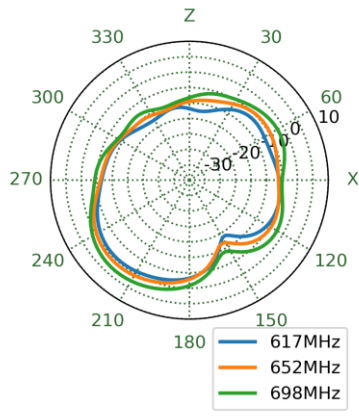
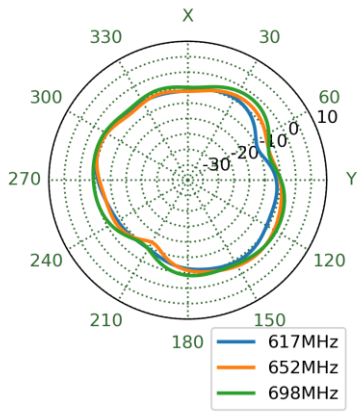

4.38 LTE 2 on 30x30cm Ground Plane Patterns at 751 MHz

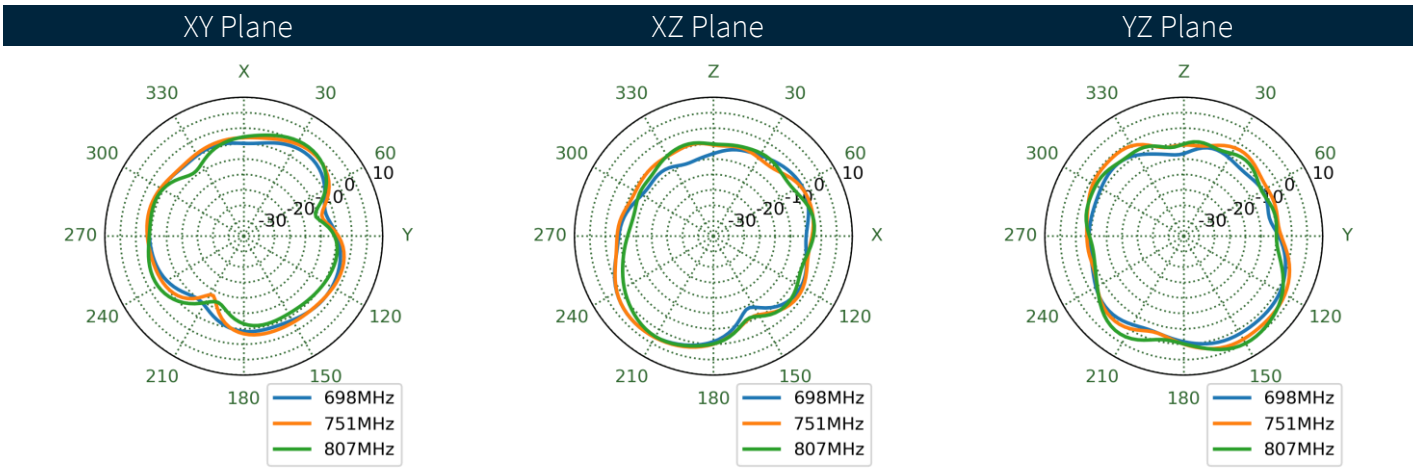
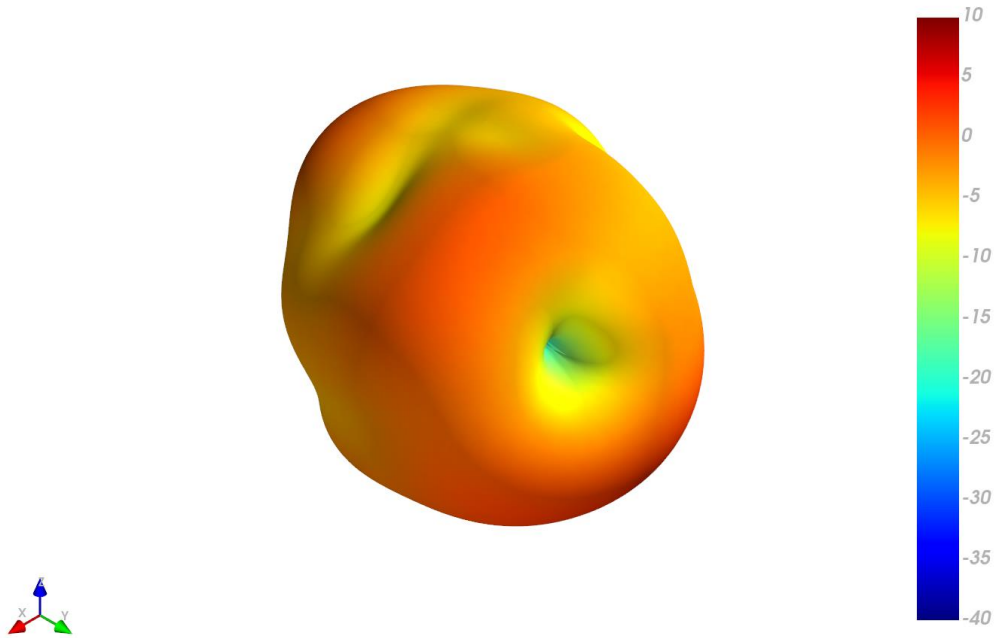

4.39 LTE 2 on 30x30cm Ground Plane Patterns at 890 MHz

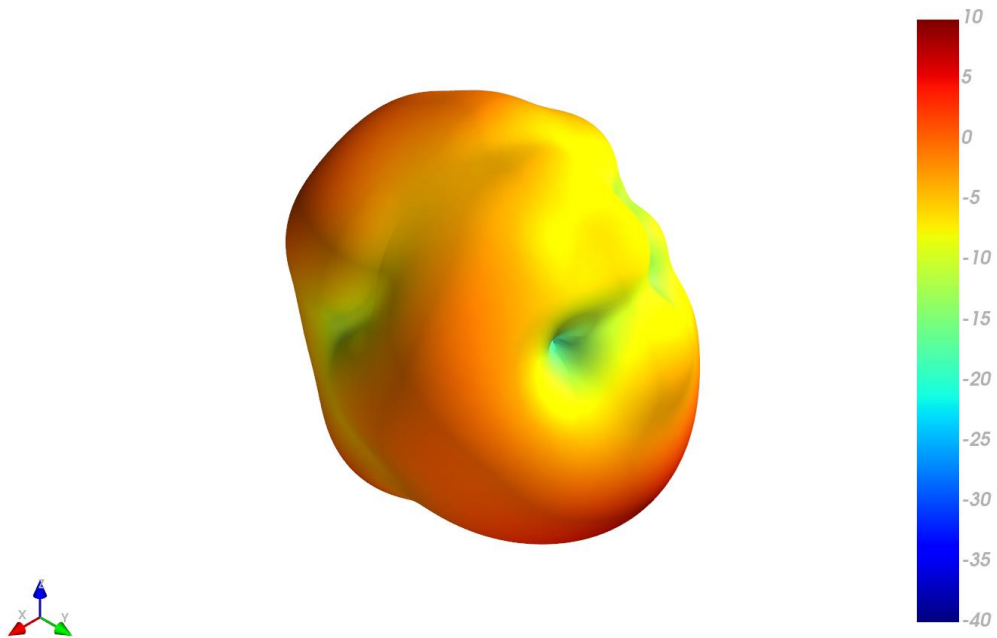

XY Plane XZ Plane YZ Plane

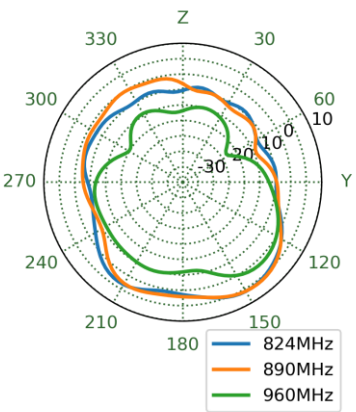
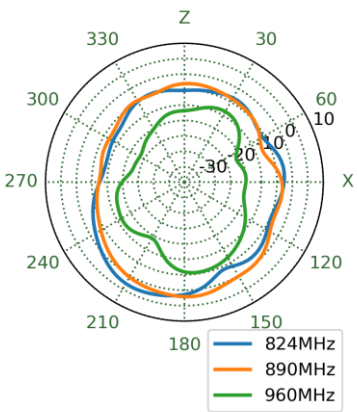
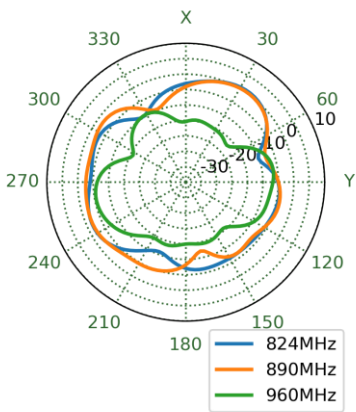



4.40 LTE 2 on 30x30cm Ground Plane Patterns at 1470 MHz

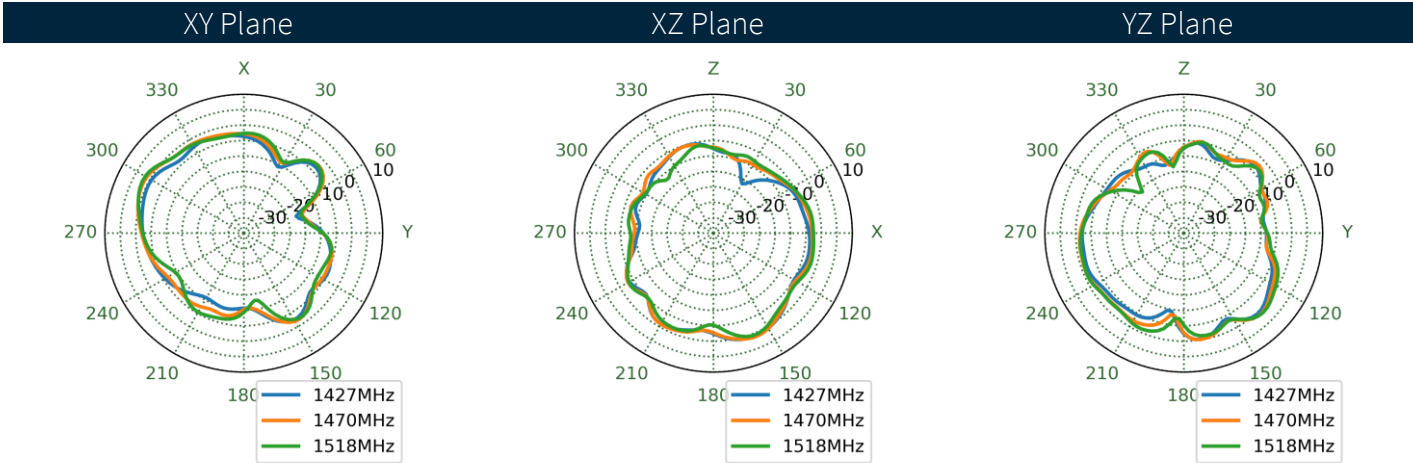
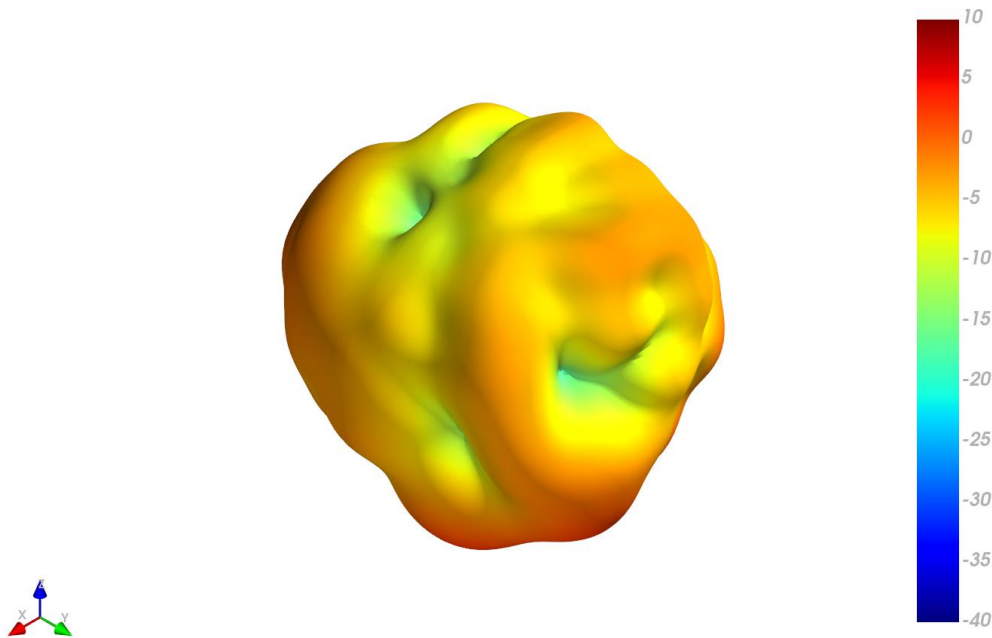

4.41 LTE 2 on 30x30cm Ground Plane Patterns at 1805 MHz

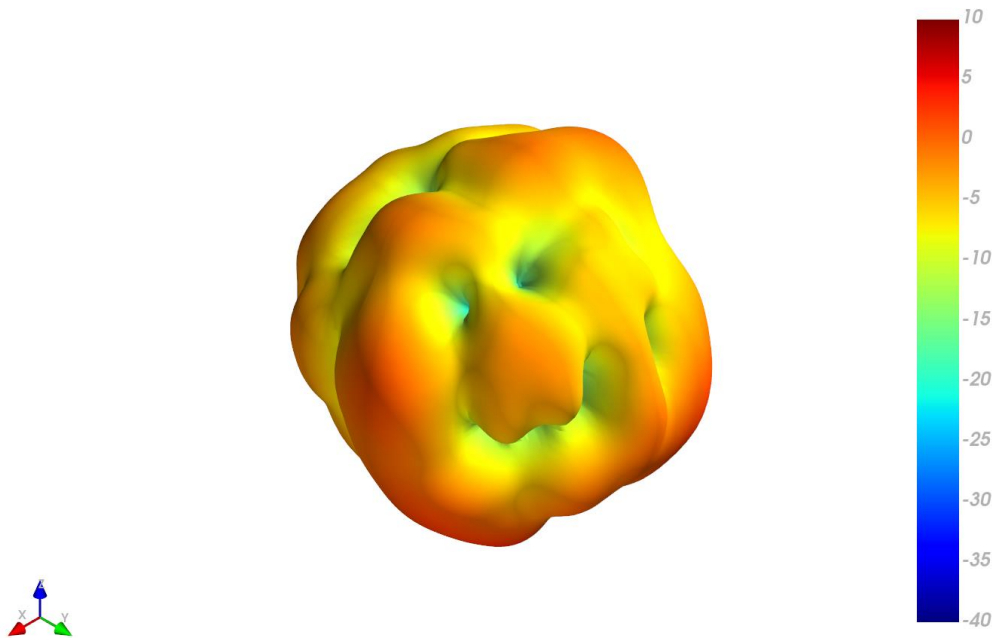

XY Plane XZ Plane YZ Plane

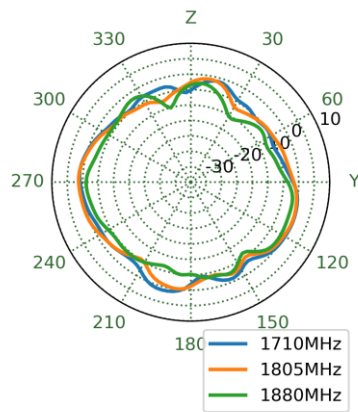
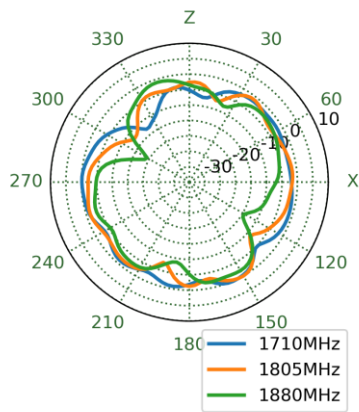
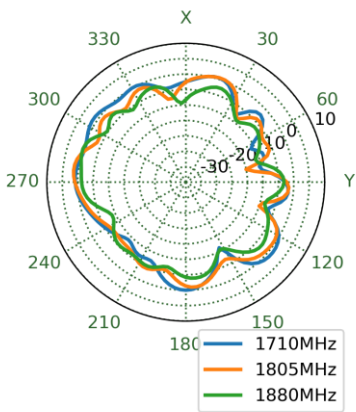

4.42 LTE 2 on 30x30cm Ground Plane Patterns at 1920 MHz

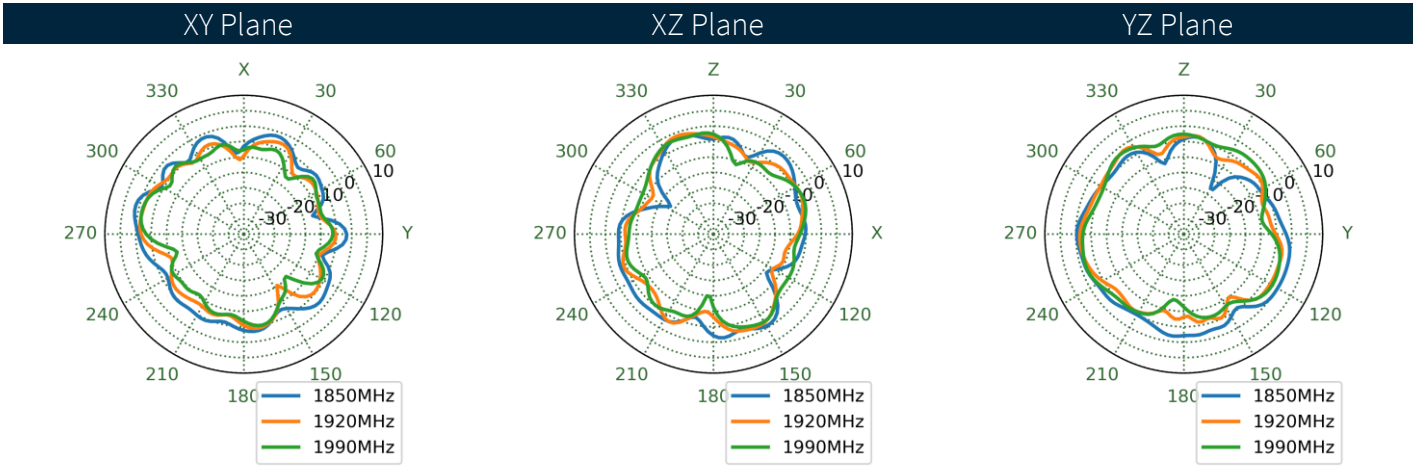
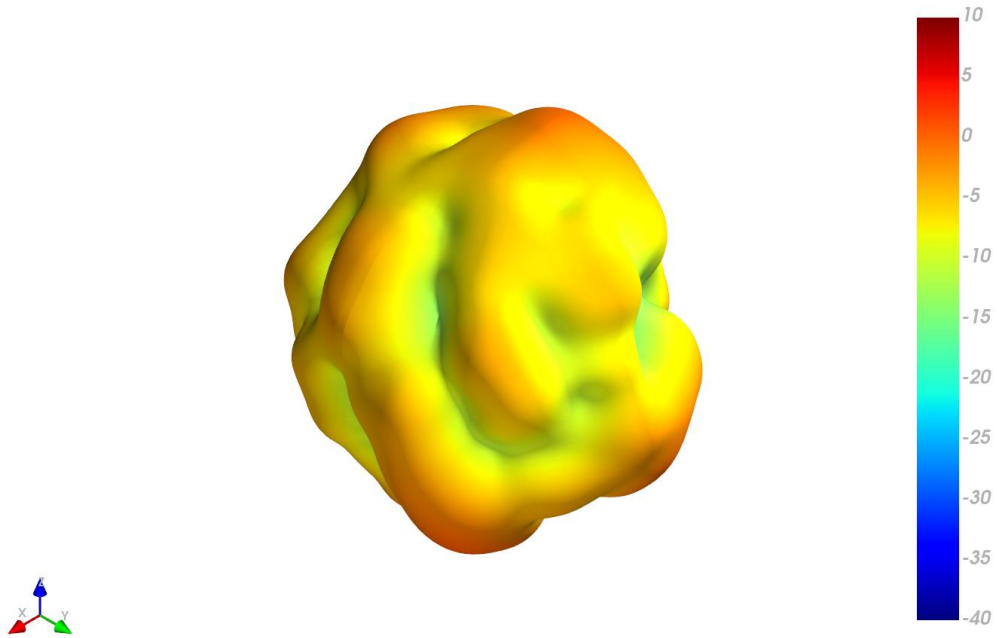

4.43 LTE 2 on 30x30cm Ground Plane Patterns at 1990 MHz

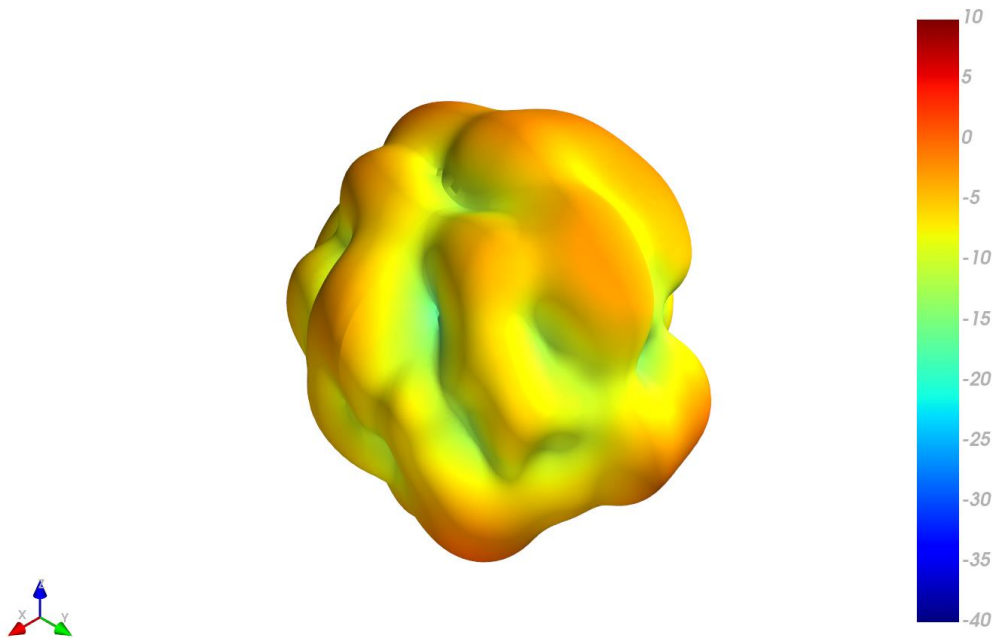

XY Plane XZ Plane YZ Plane

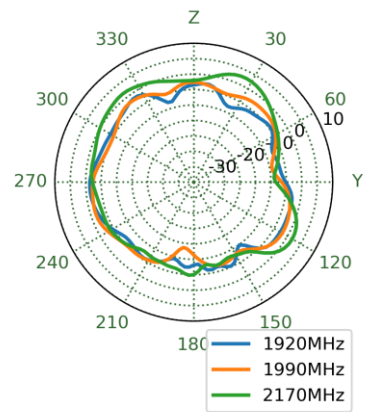
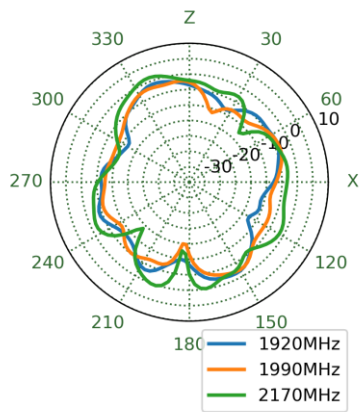
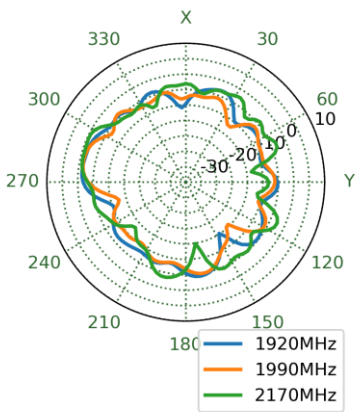

4.44 LTE 2 on 30x30cm Ground Plane Patterns at 2595 MHz

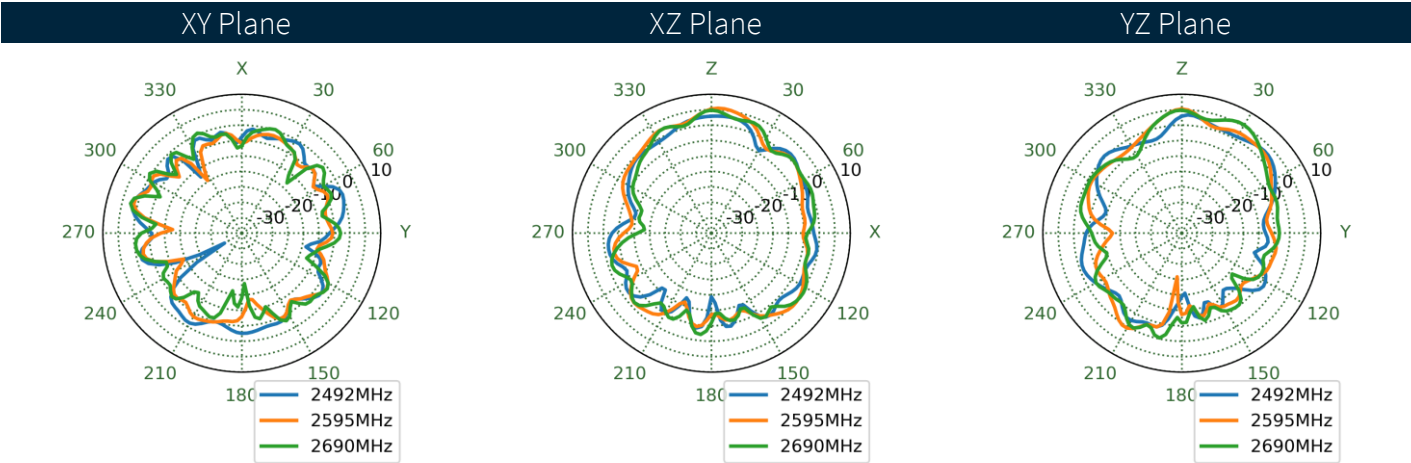
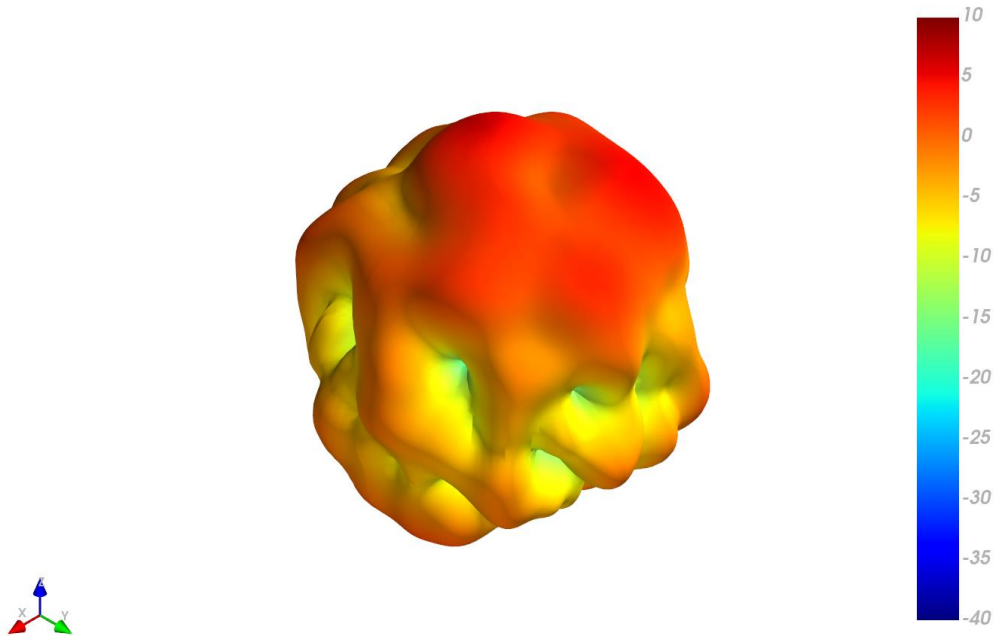

**4.45** LTE 2 on 30x30cm Ground Plane Patterns at 3550 MHz

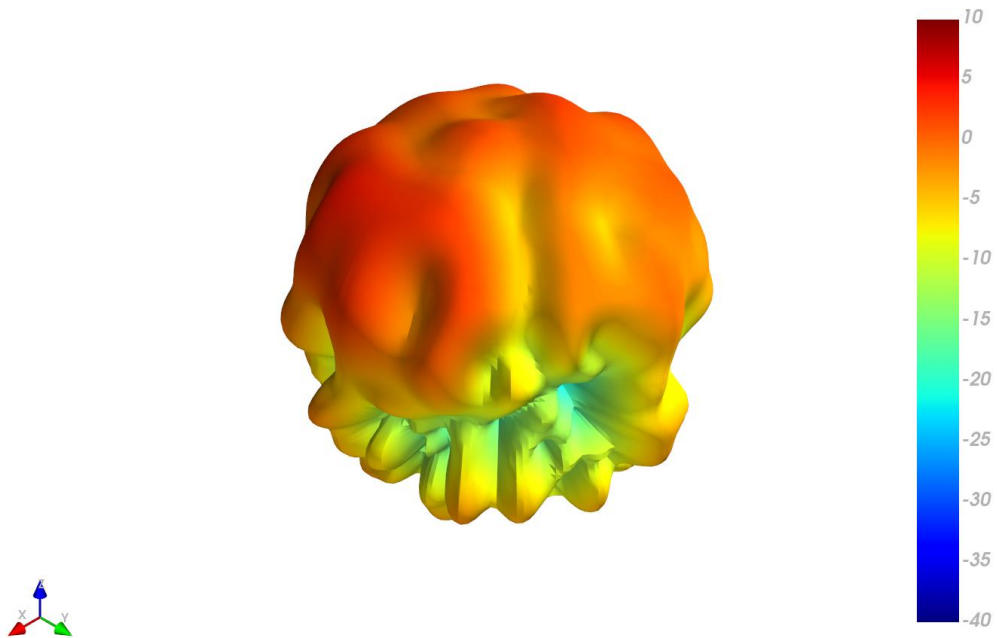

**XY Plane                      XZ Plane                      YZ Plane**

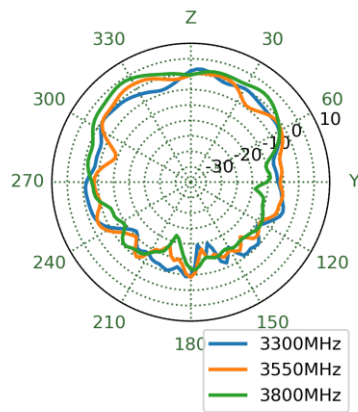
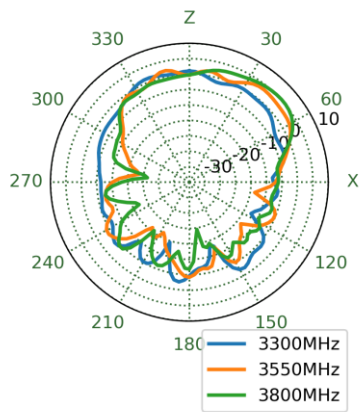
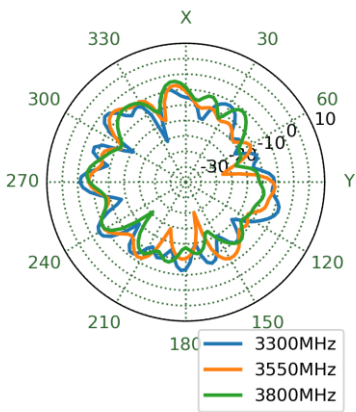

## 4.46 LTE 2 on 30x30cm Ground Plane Patterns at 4600 MHz

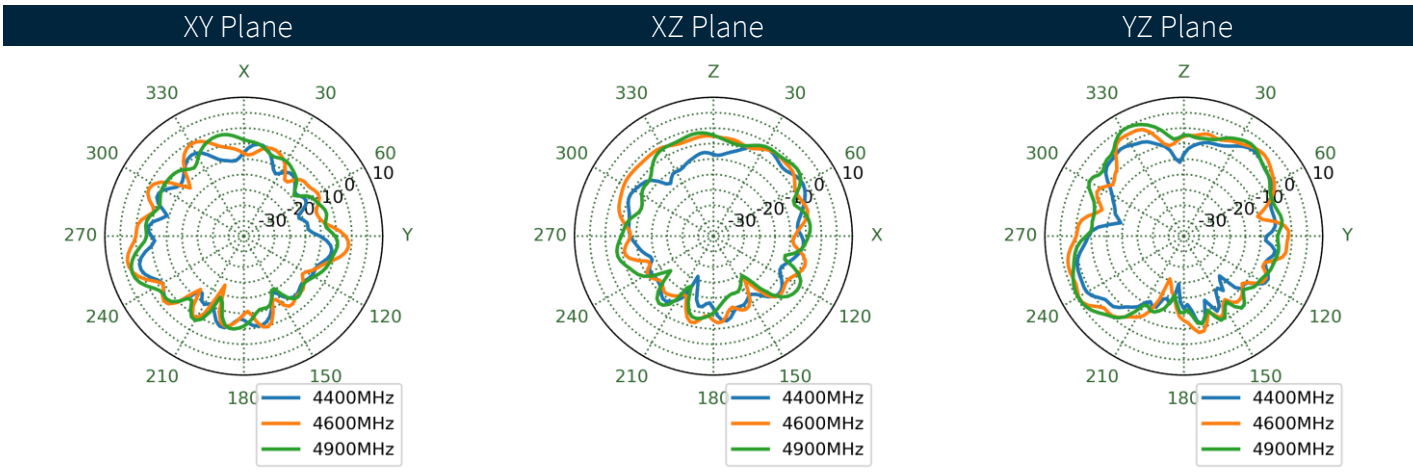
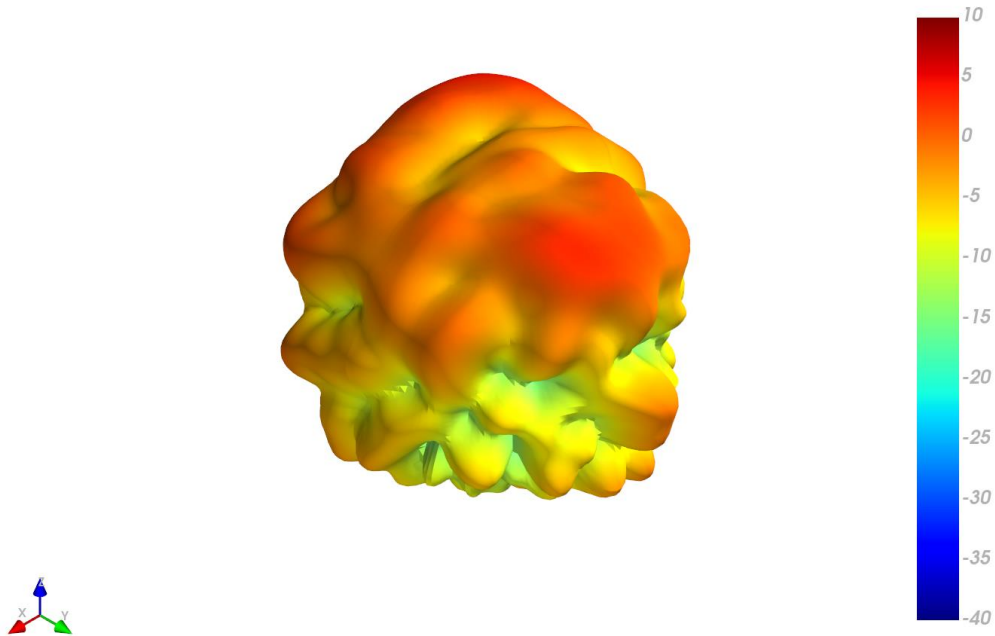

4.47 LTE 2 on 30x30cm Ground Plane Patterns at 4800 MHz

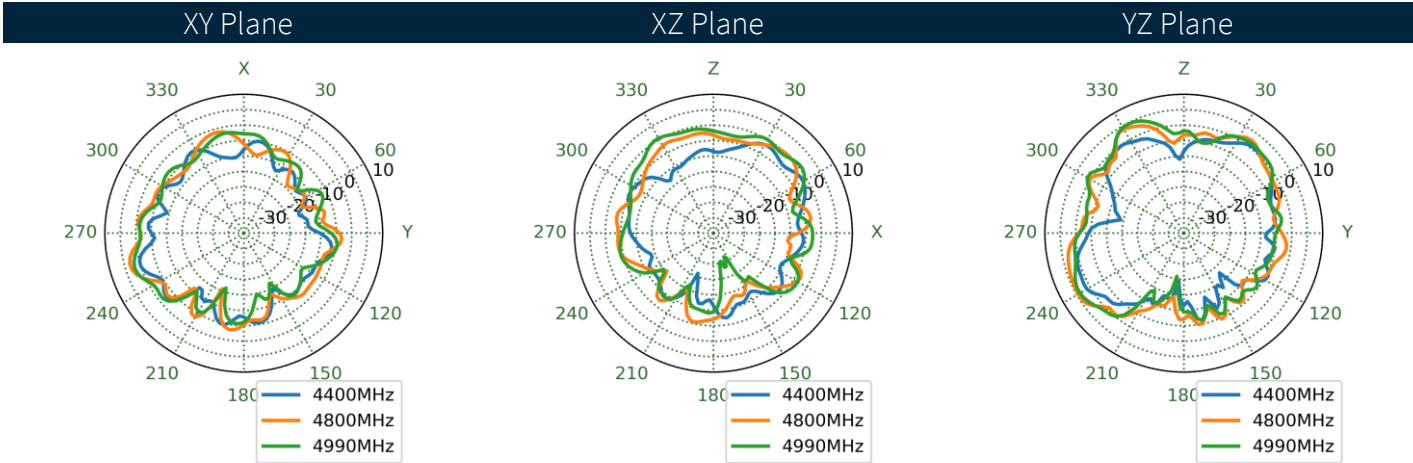
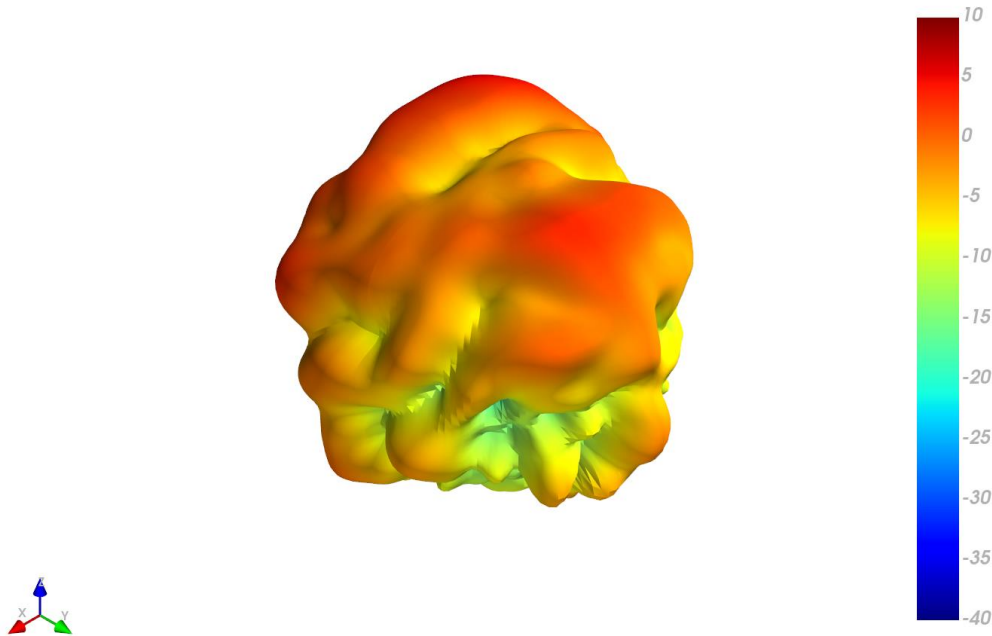



4.48 LTE 2 on 30x30cm Ground Plane Patterns at 5530 MHz

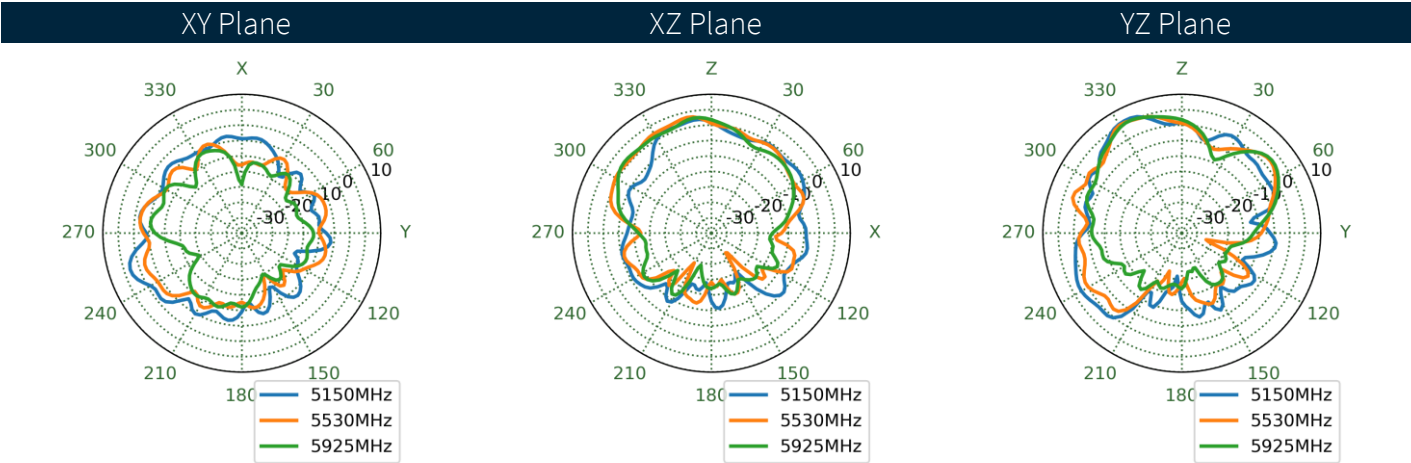
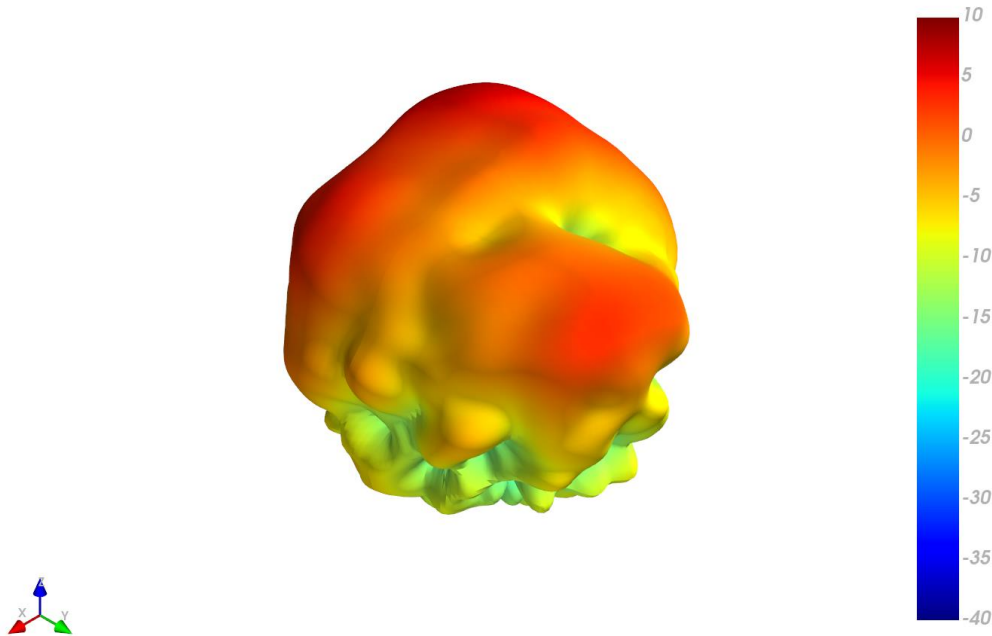

4.49 GNSS in Free Space Patterns at 1561 MHz

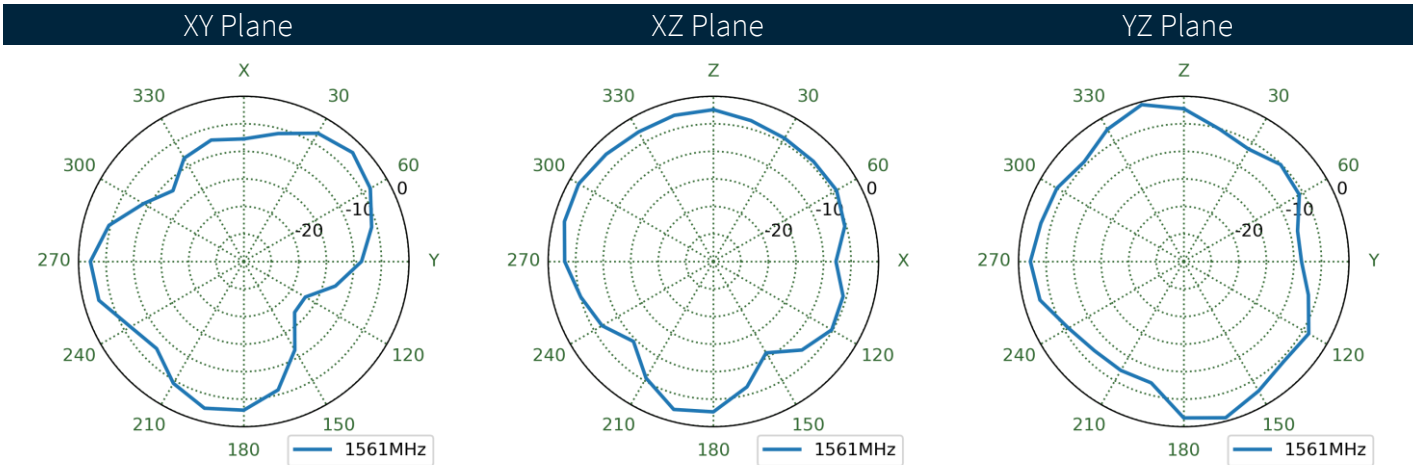
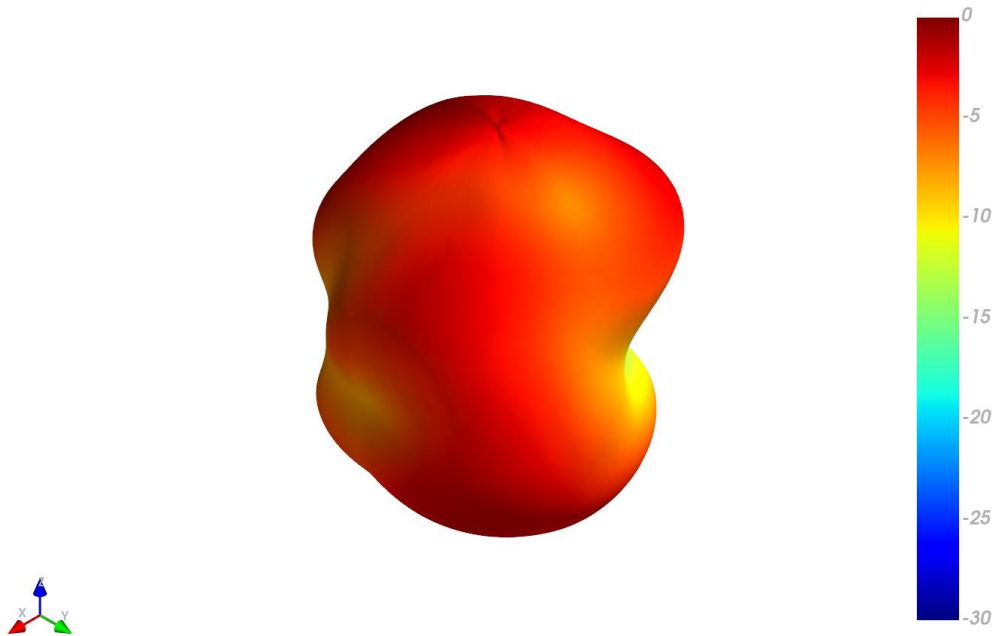

4.50 GNSS in Free Space Patterns at 1575 MHz

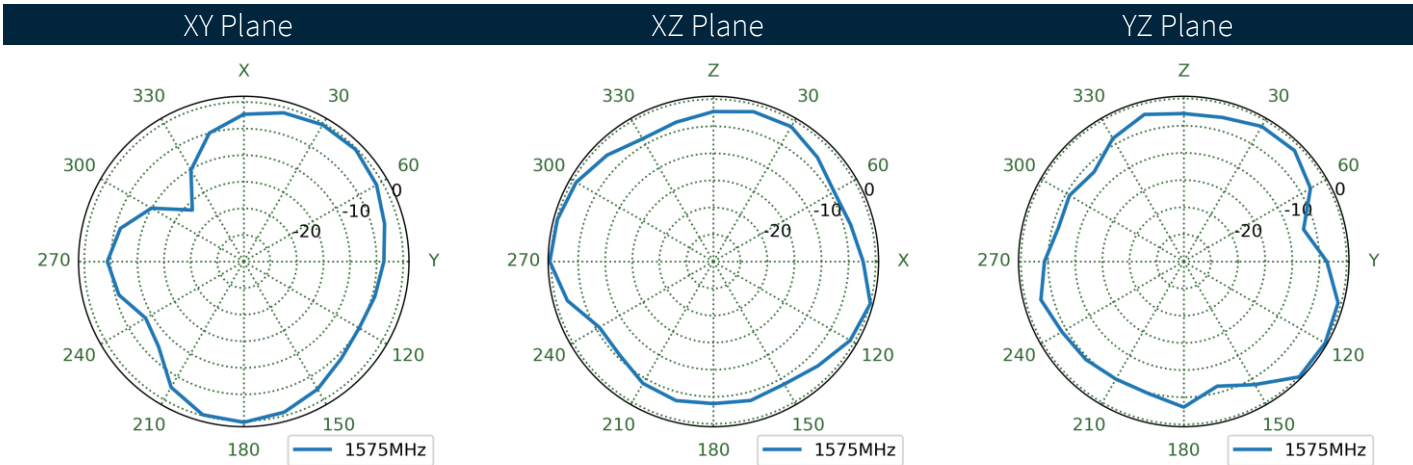
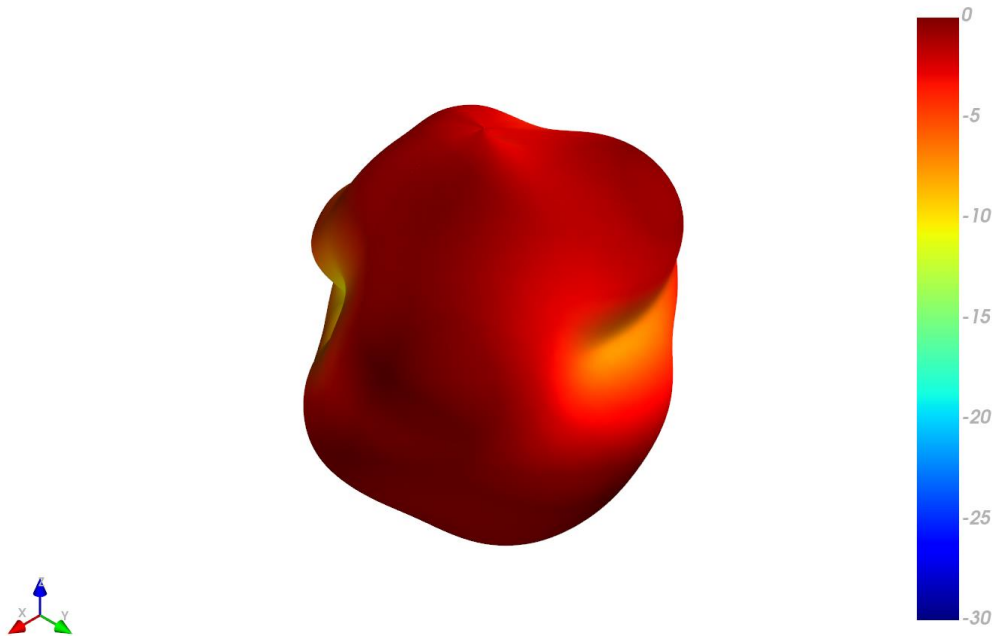

4.51 GNSS in Free Space Patterns at 1602 MHz

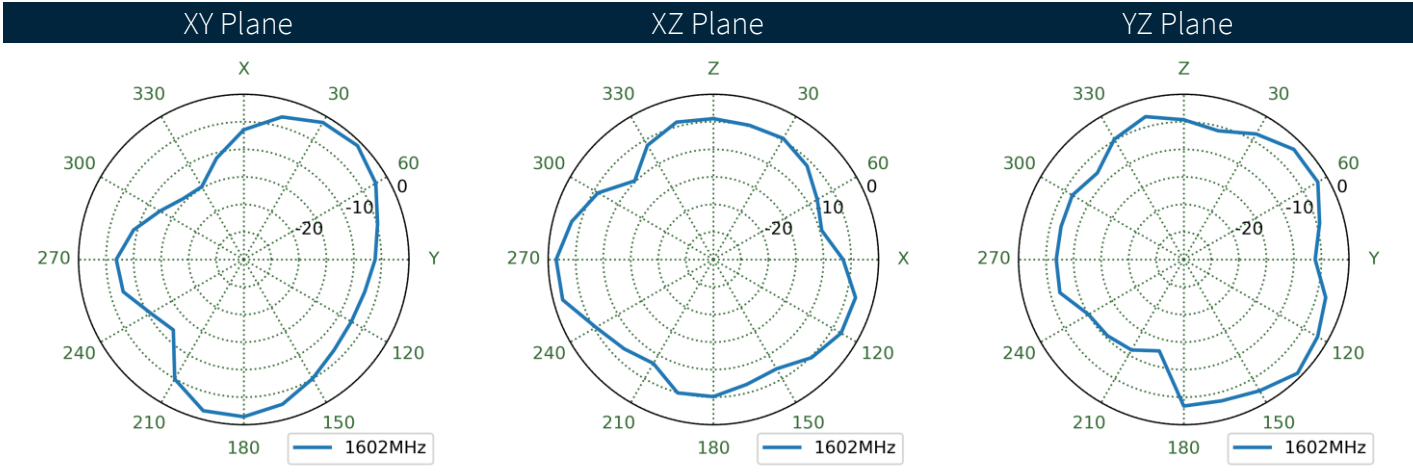
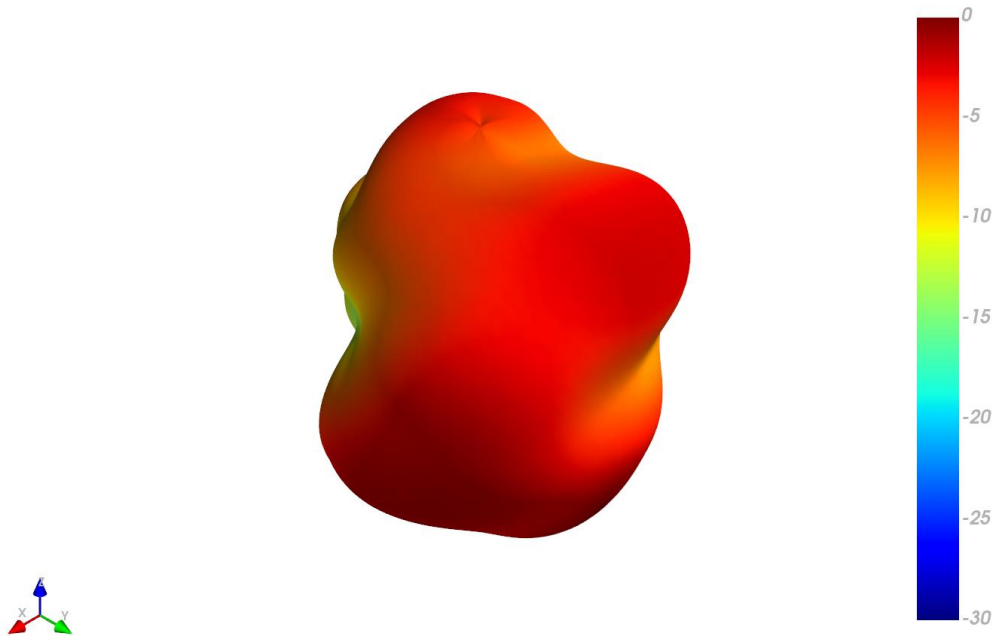

4.52 GNSS on 30x30cm Ground Plane Patterns at 1561 MHz

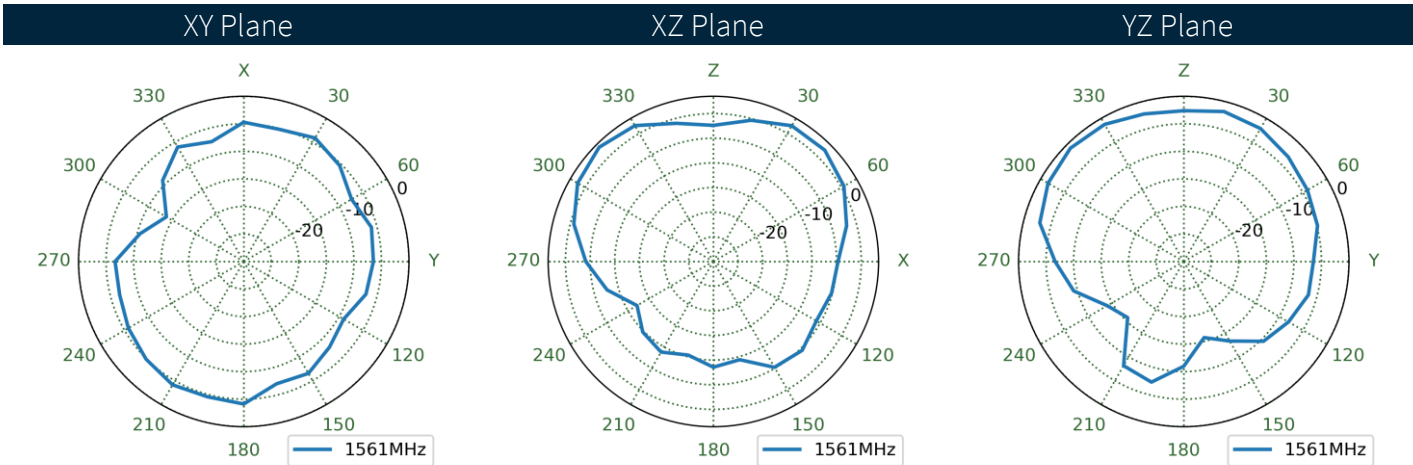
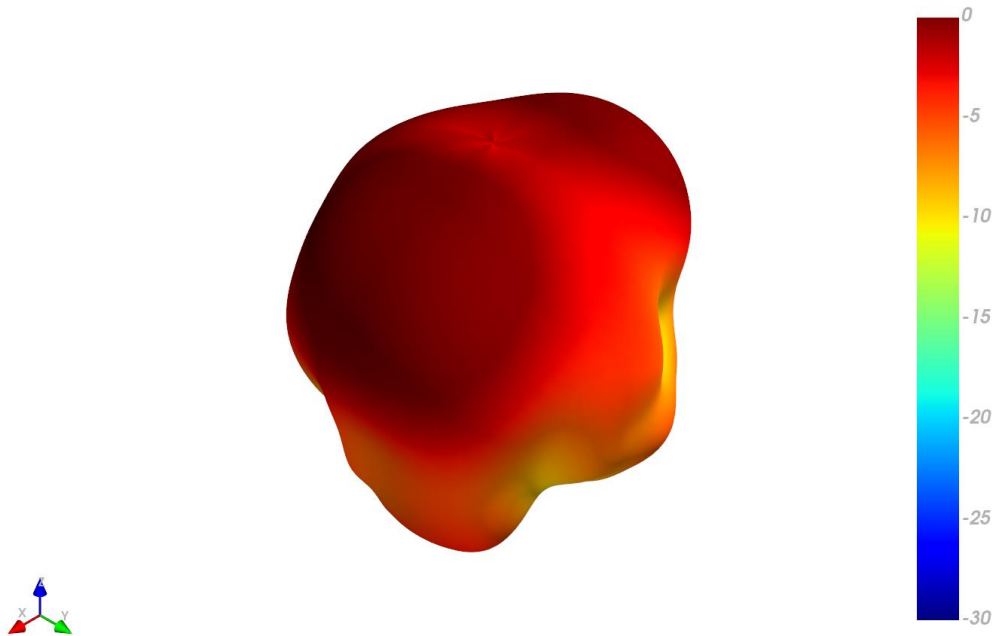

4.53 GNSS on 30x30cm Ground Plane Patterns at 1575 MHz

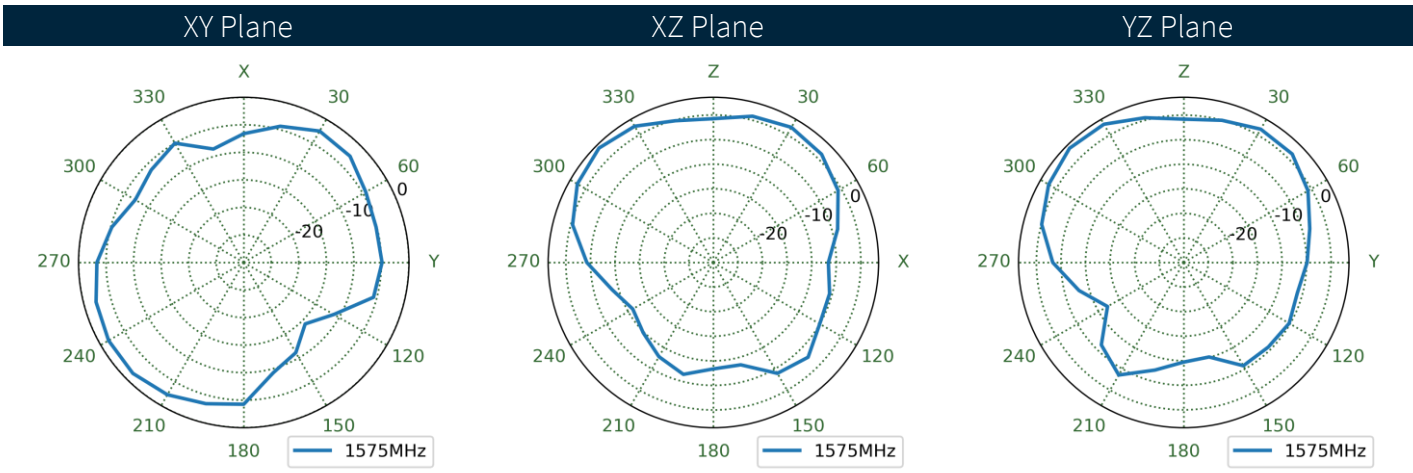
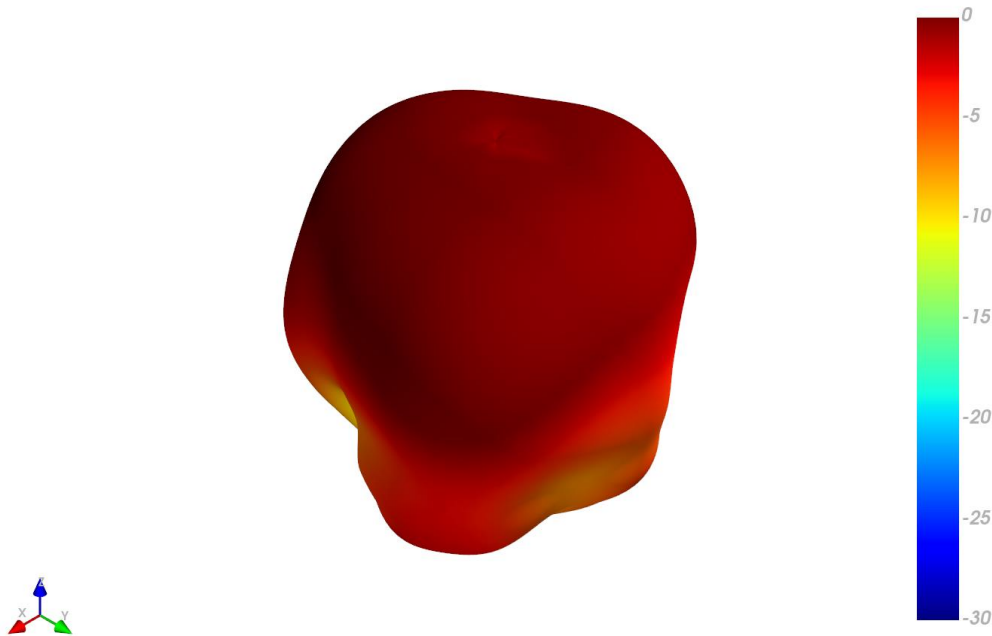

4.54 GNSS on 30x30cm Ground Plane Patterns at 1602 MHz

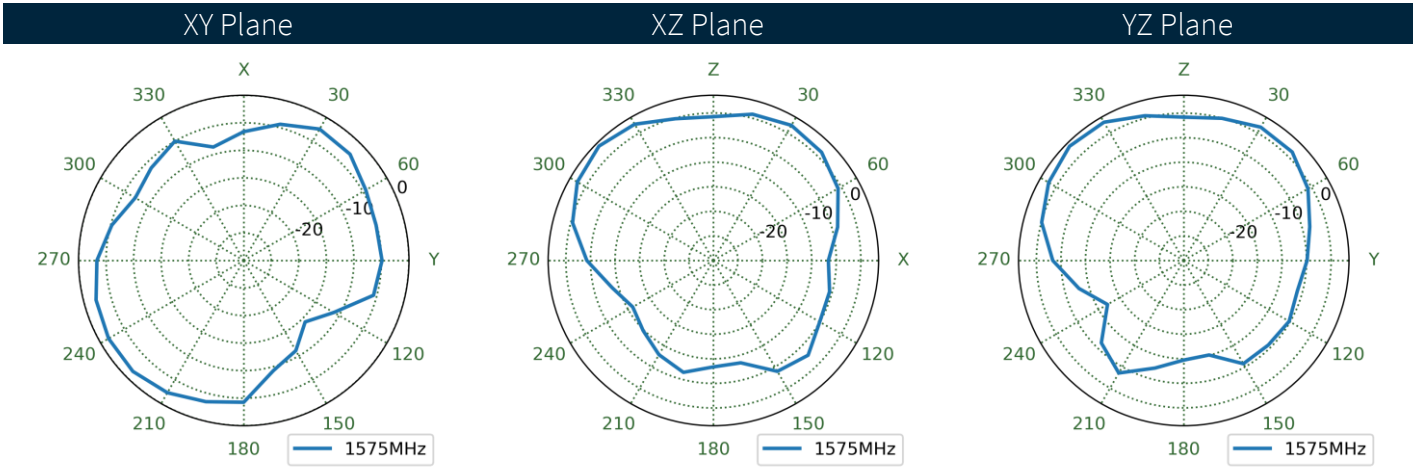
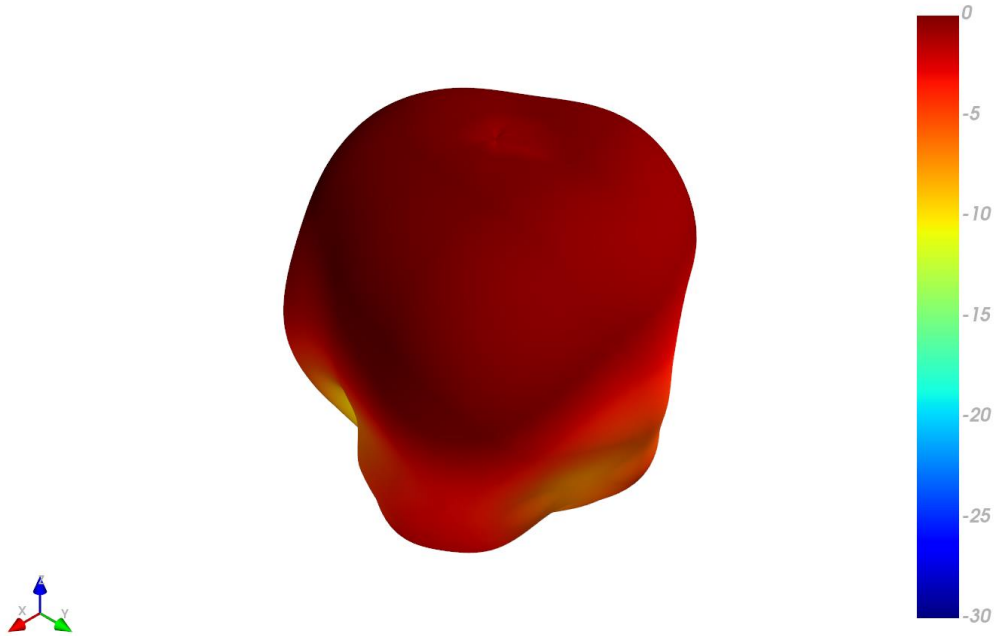

# 5. Mechanical Drawing

ISO NO.: EDW-23-8-0280

STATE: Released

- NOTES:
1. All material must be RoHS compliant.
  2. Use this drawing together with the corresponding 3D CAD database file to fully describe the part.
  3. Critical Dimensions are indicated by the inspection symbol  $\square$ .
  4. Glue magnet to base using Super-X SILICONE ADHESIVE. PART SURFACES MUST BE CLEANED PRIOR TO ASSEMBLY. ASSEMBLY MAGNET AFTER HEAT STAKING AND ULTRASONIC WELDING PROCESSES

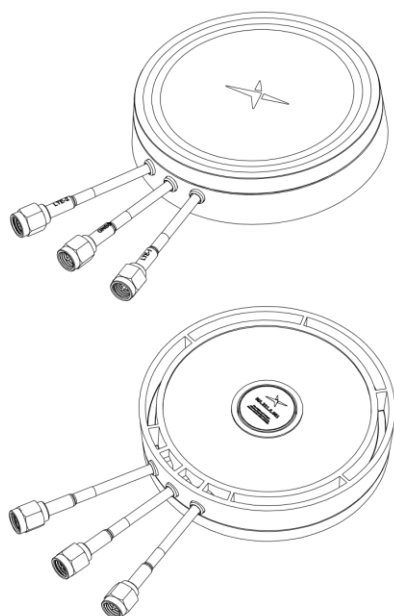
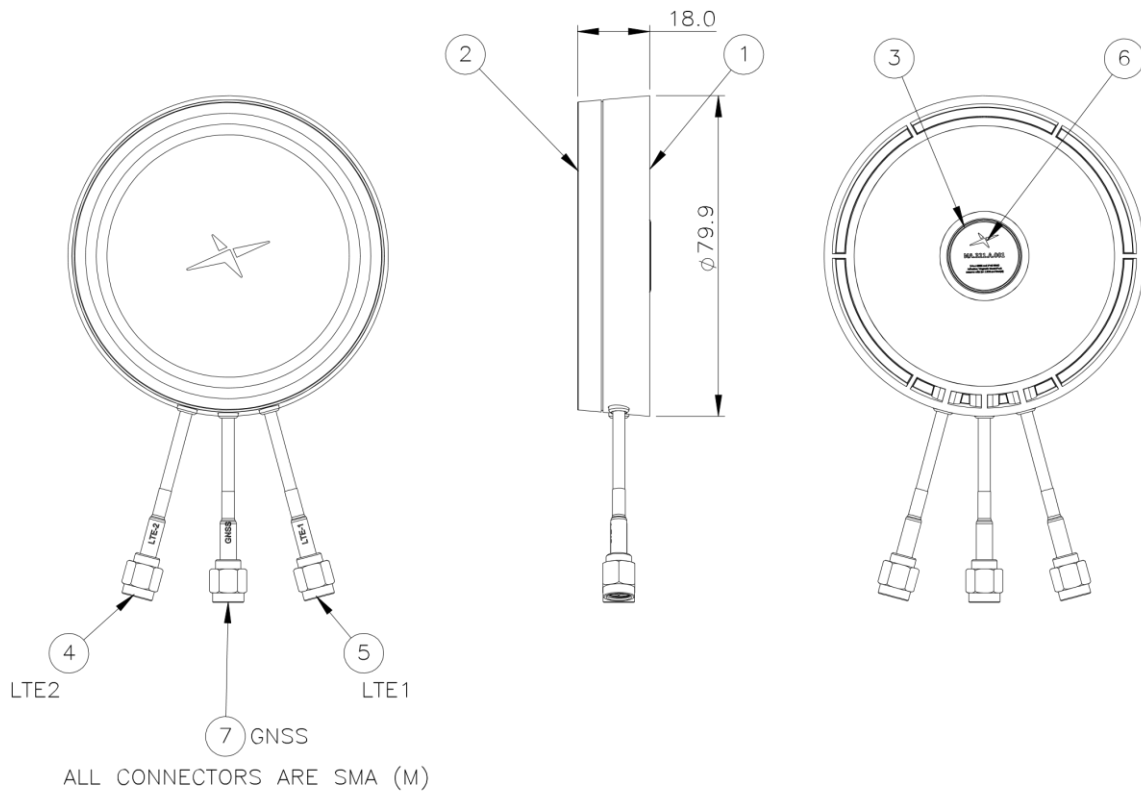

FN	DESCRIPTION	MATERIAL	FINISH	QTY
1	Bottom Housing 3 Hole	ASA	BLACK	1
2	Top Housing	ASA	BLACK	1
3	Magnet pack/N48	N48	Ni	1
4	Cable Assy 2m 1.5DS LTE2	NA	NA	1
5	Cable Assy 2m 1.5DS LTE1	NA	NA	1
6	PRODUCT LABEL MA321.A.001	Polyester	NA	1
7	Cable Assy 2m 1.5DS GNSS	NA	NA	1



## 6. Packaging

MA321.A.001  
1 PCS Tape/ Small PE Bag



1 PCS /PE Bag



70 PCS/ Cartoon  
2 PCS/ Cartoon Board  
Carton Dimensions: 355x355x275mm  
Carton Label

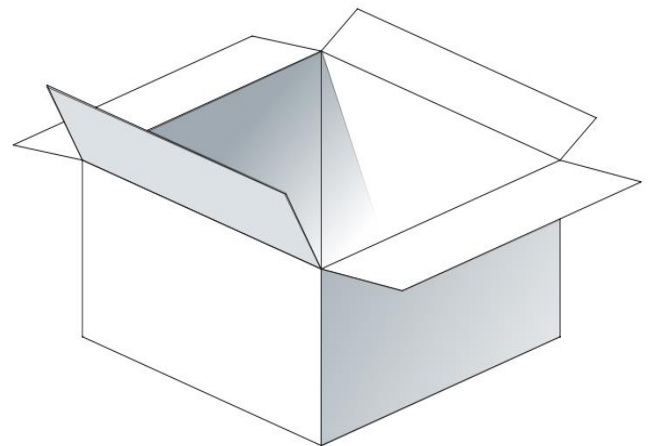

# 7. Application Note

## 7.1 Efficiency

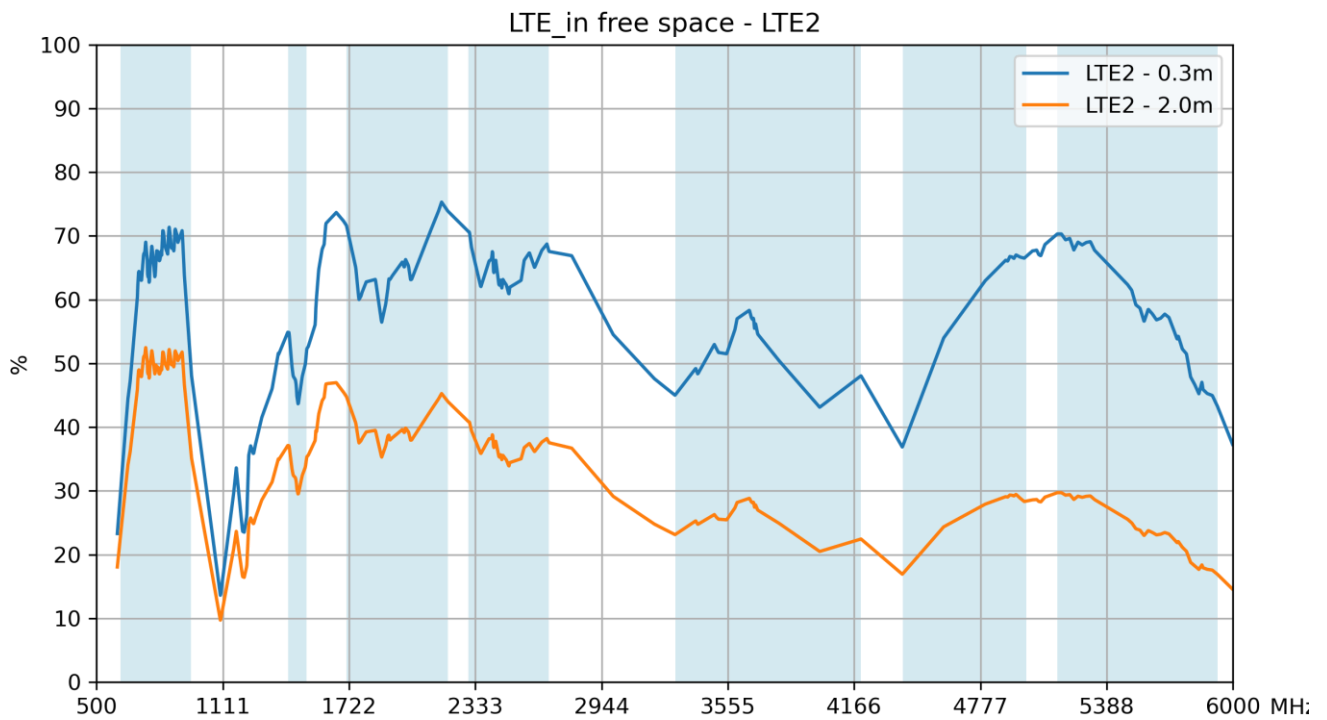
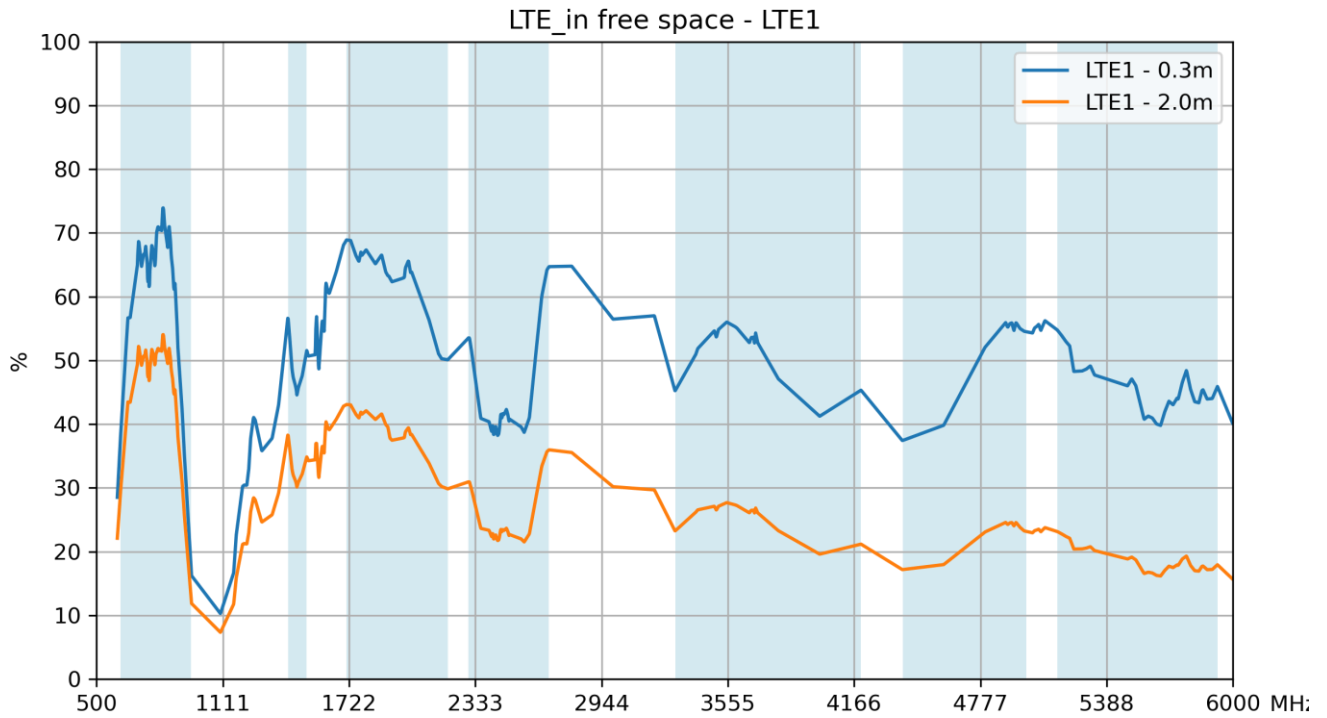

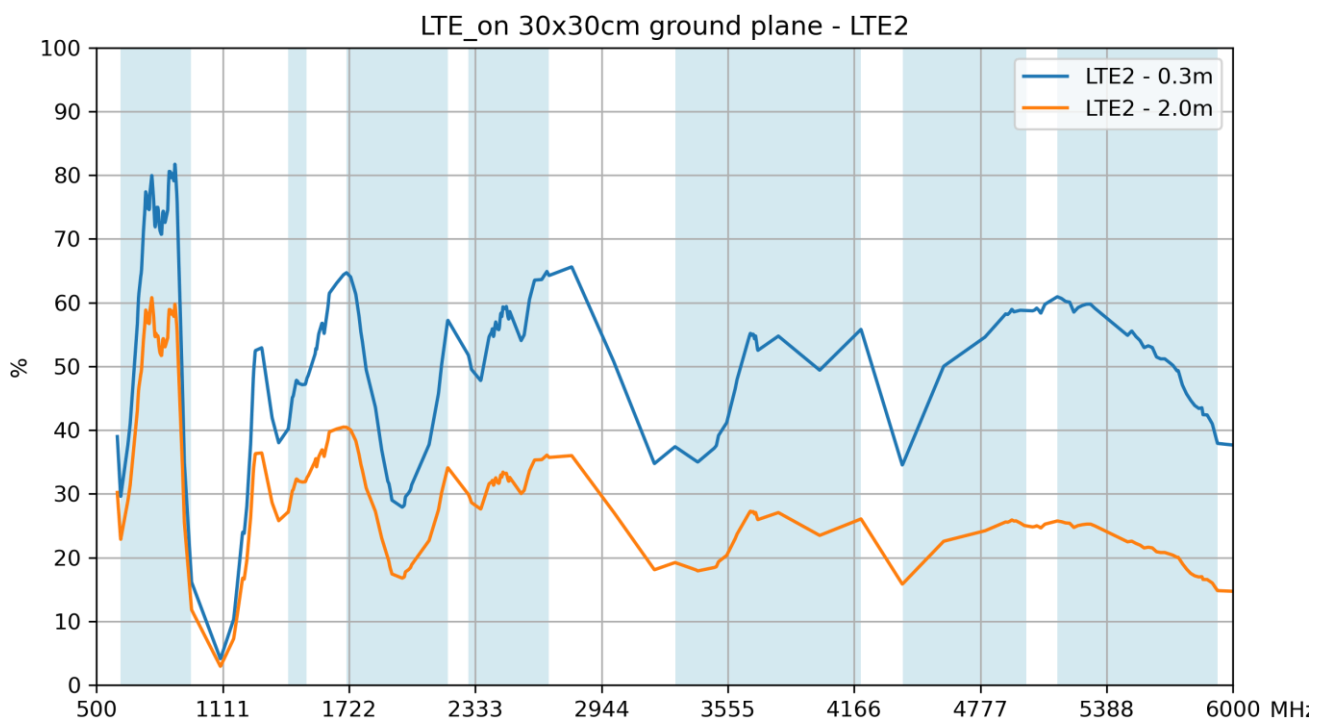
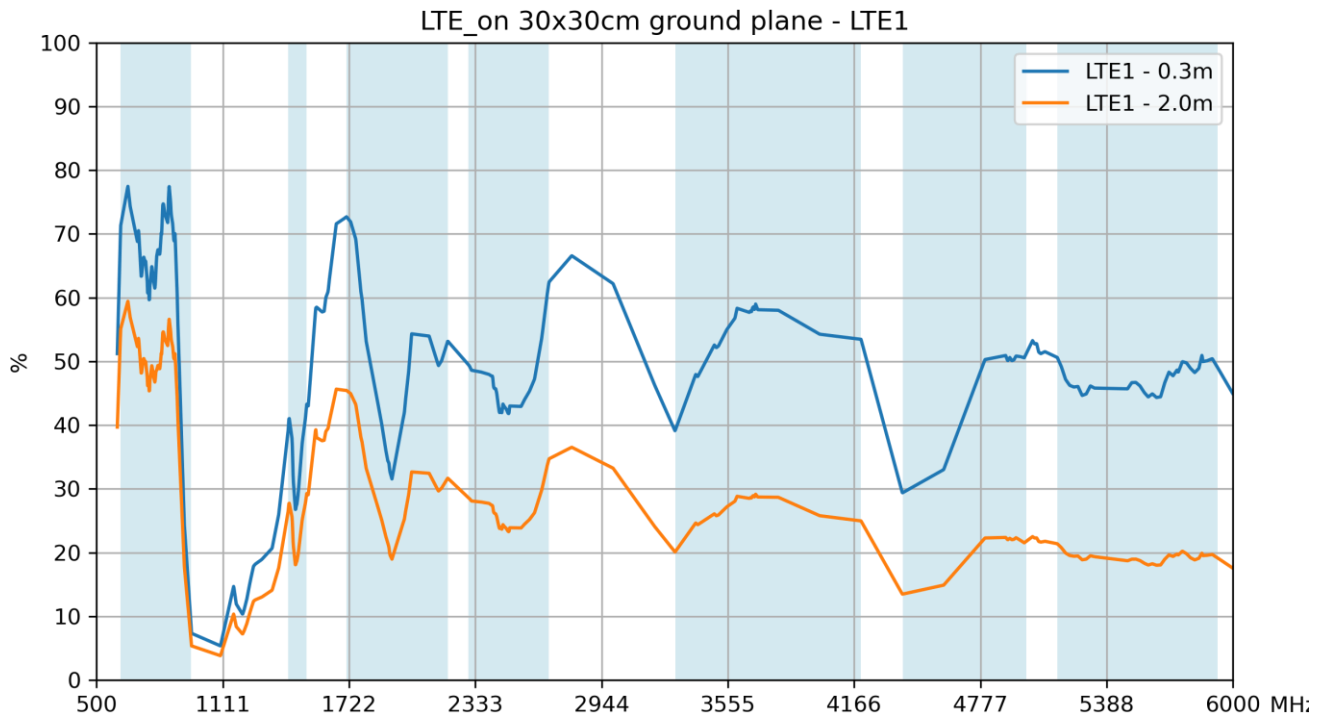

## 7.2 Average Gain

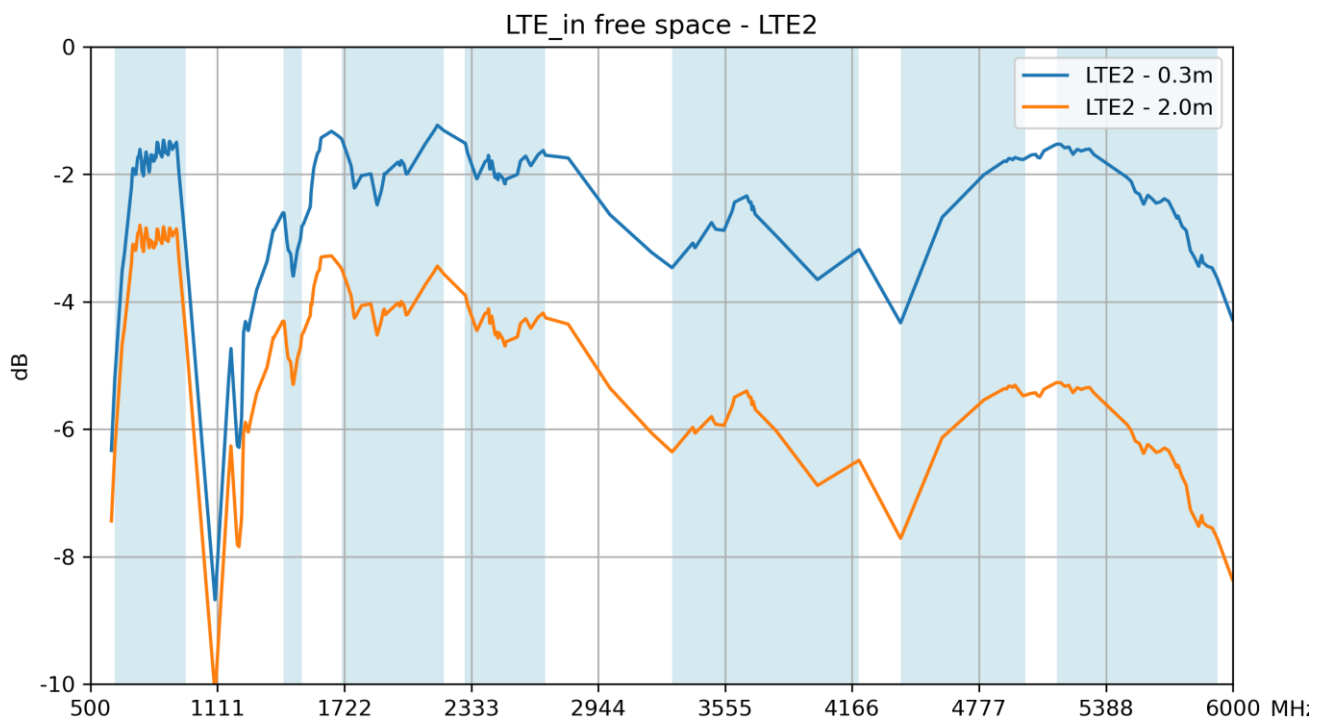
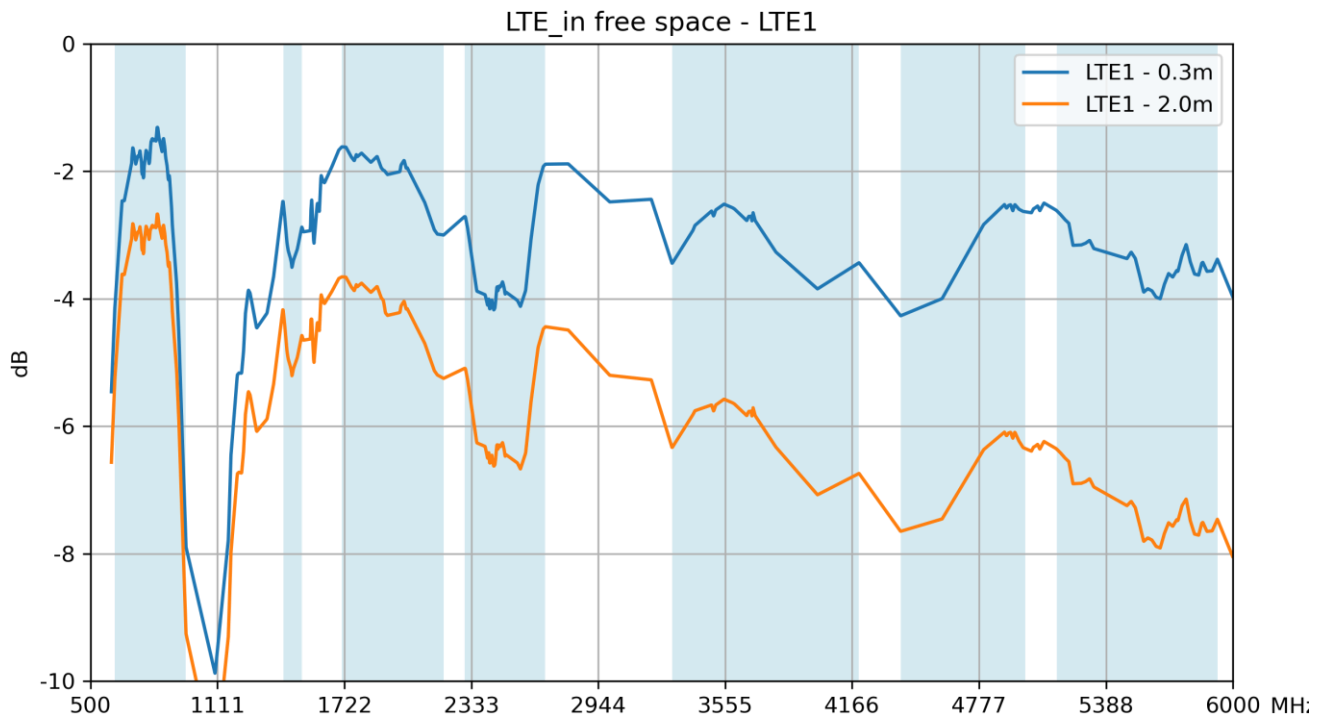

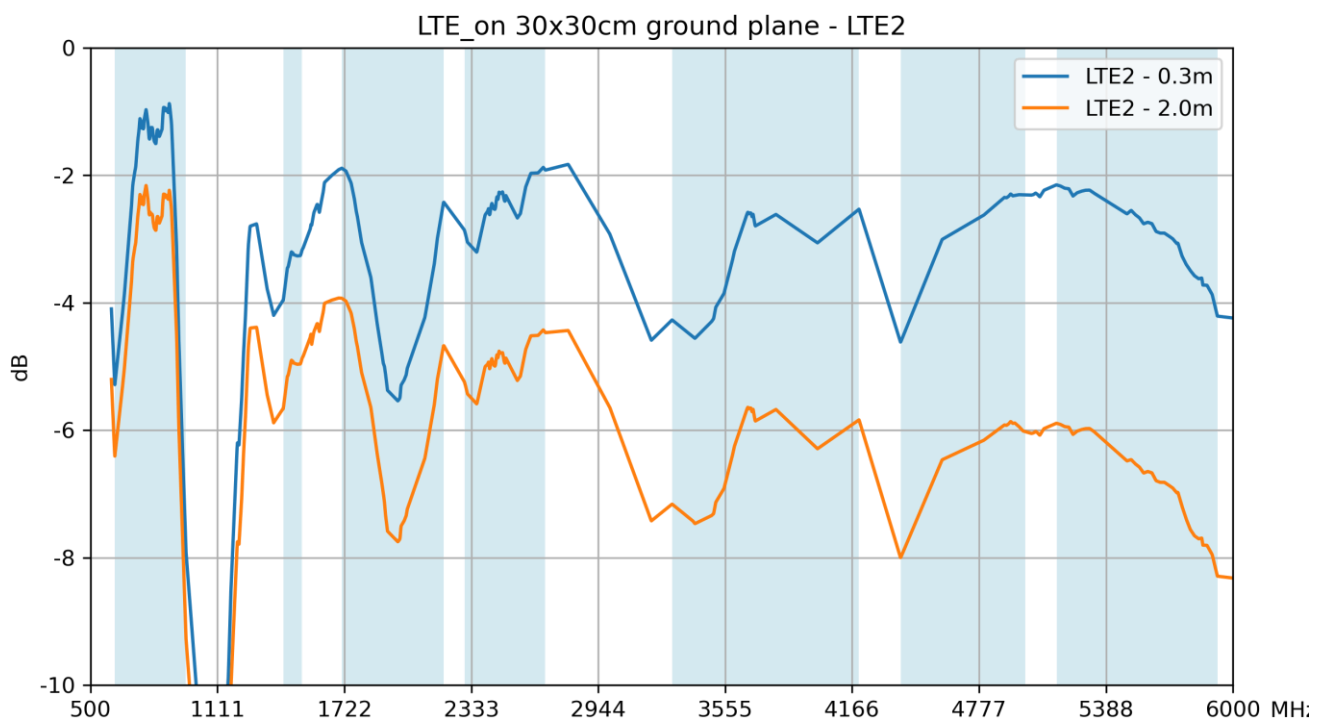
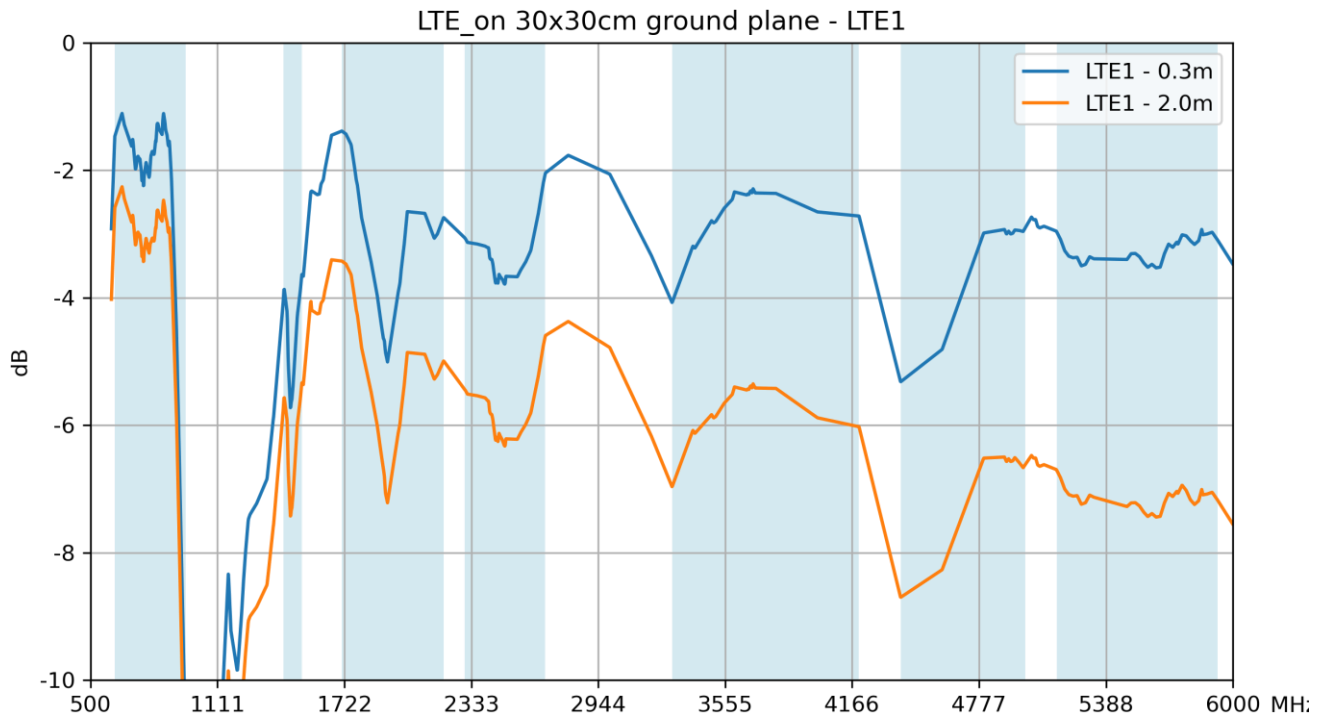

### 7.3 Peak Gain

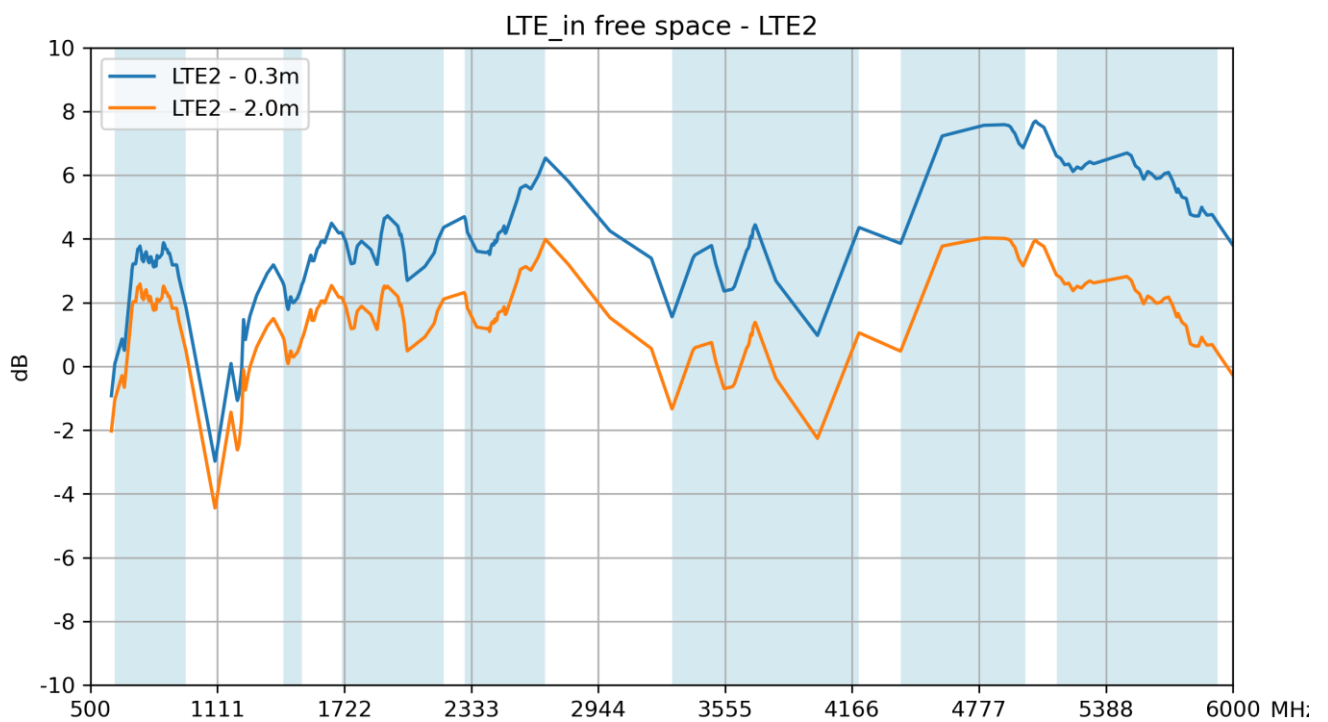
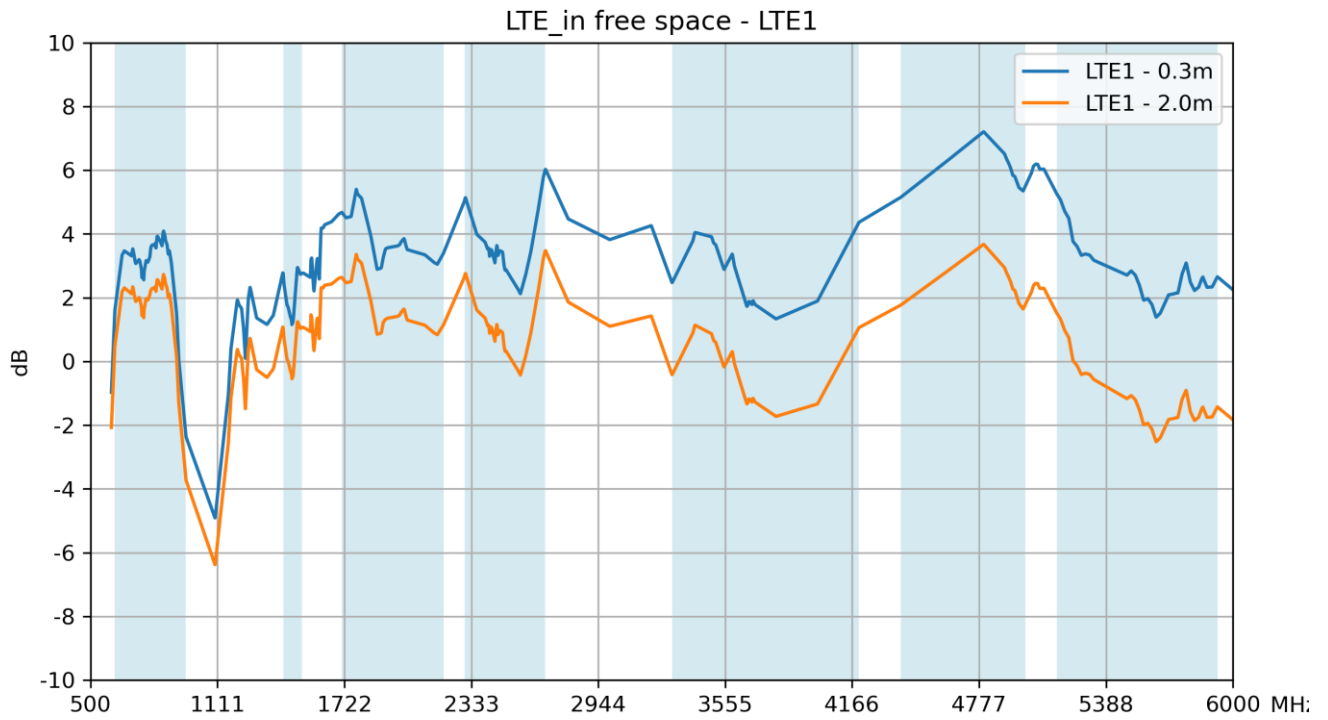

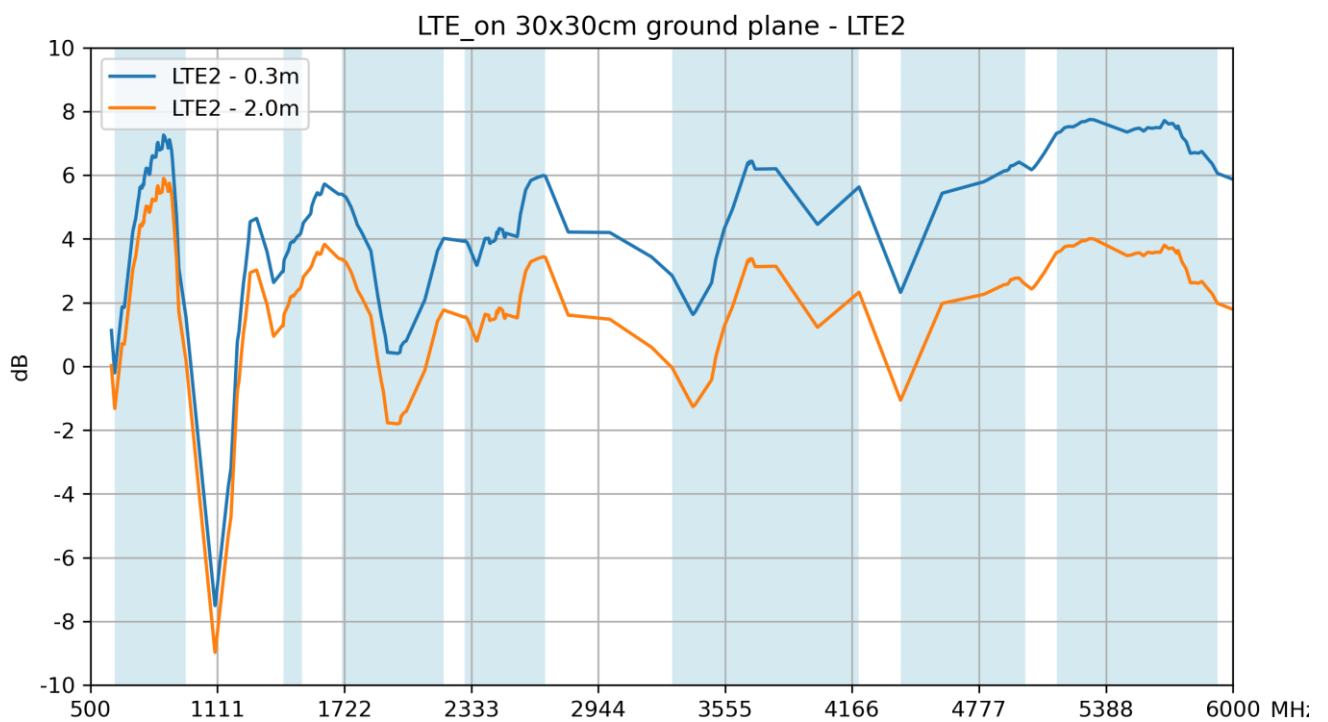
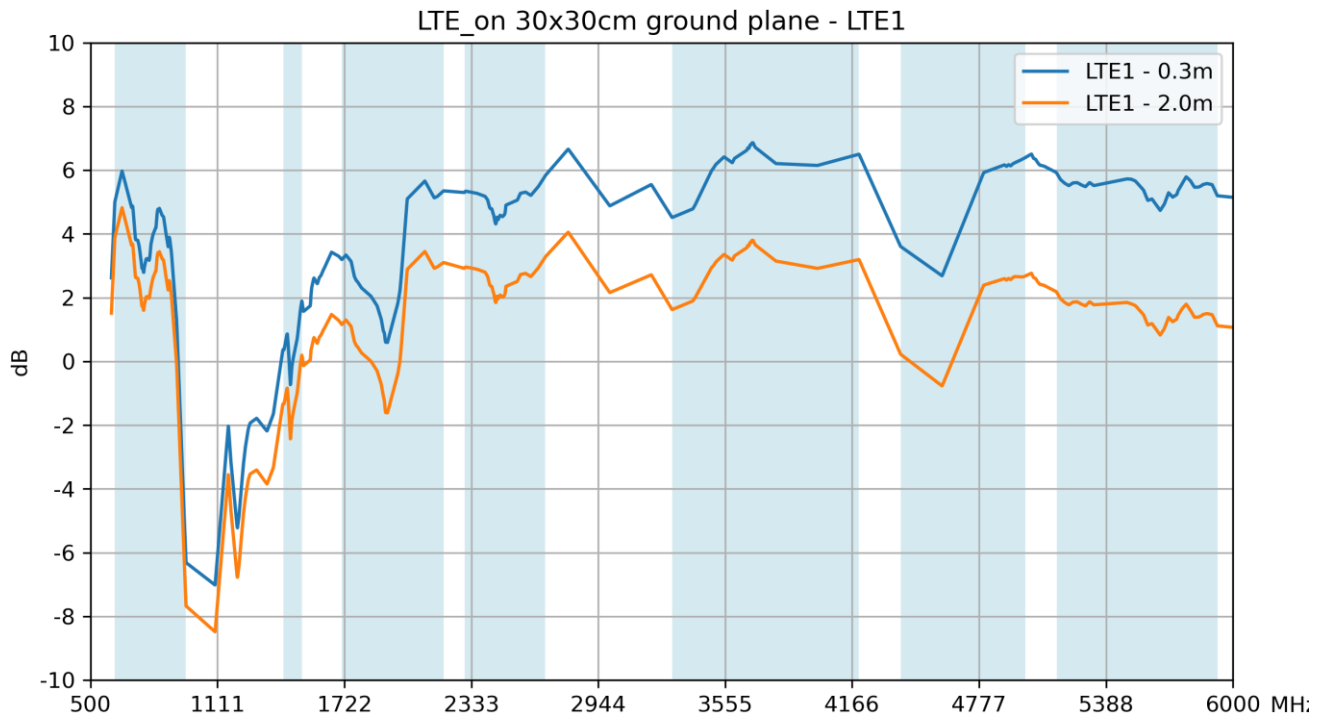

## 7.4 Efficiency

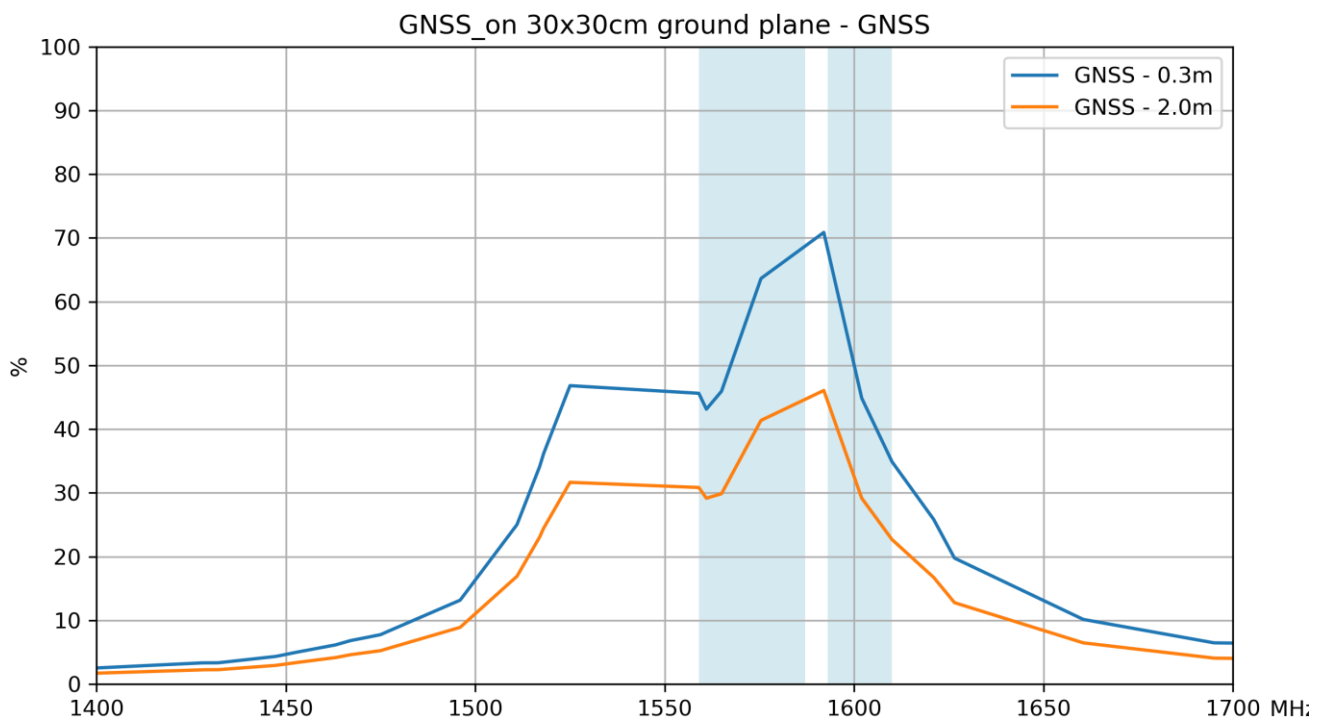
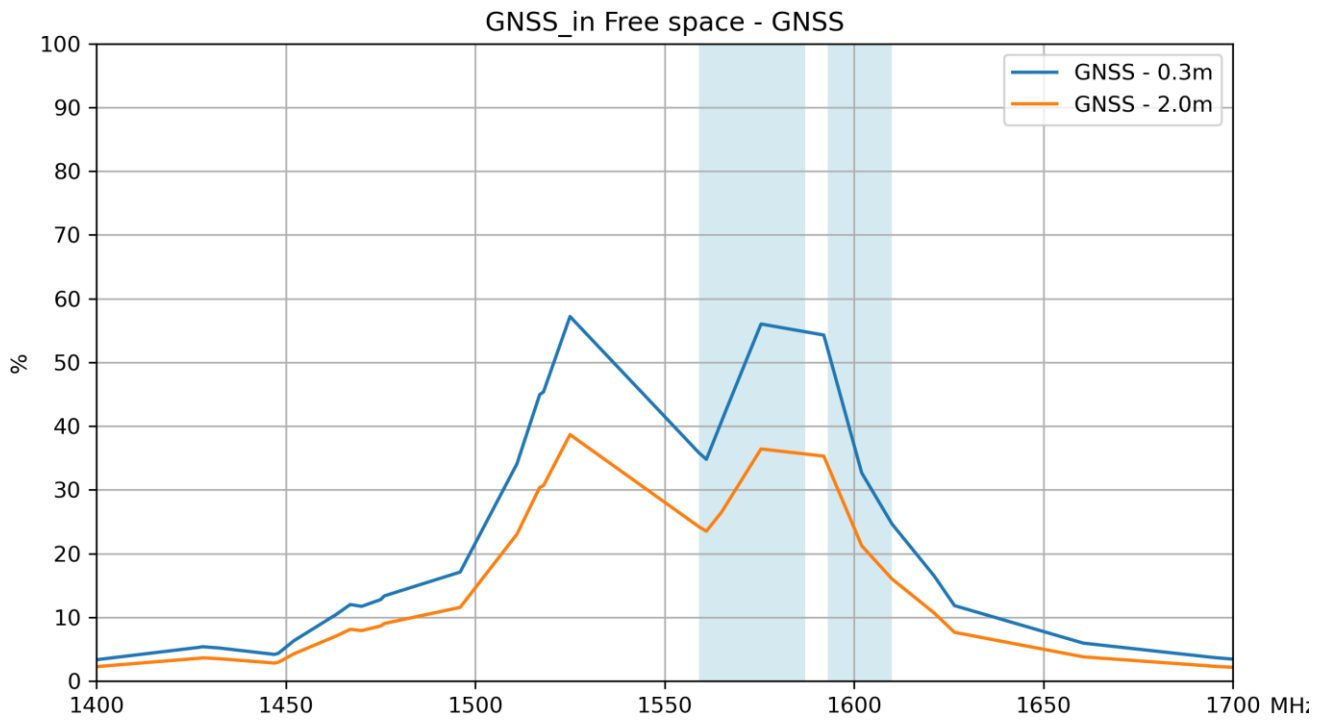



## 7.5 Average Gain

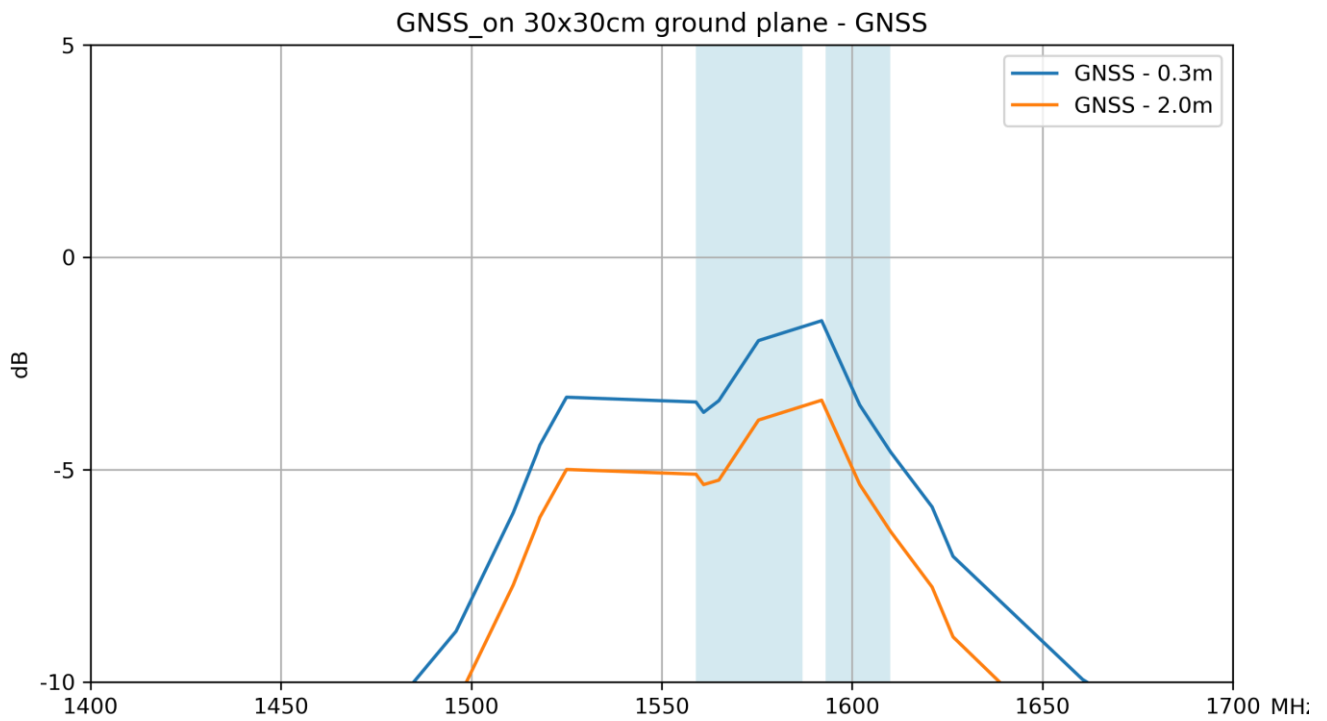
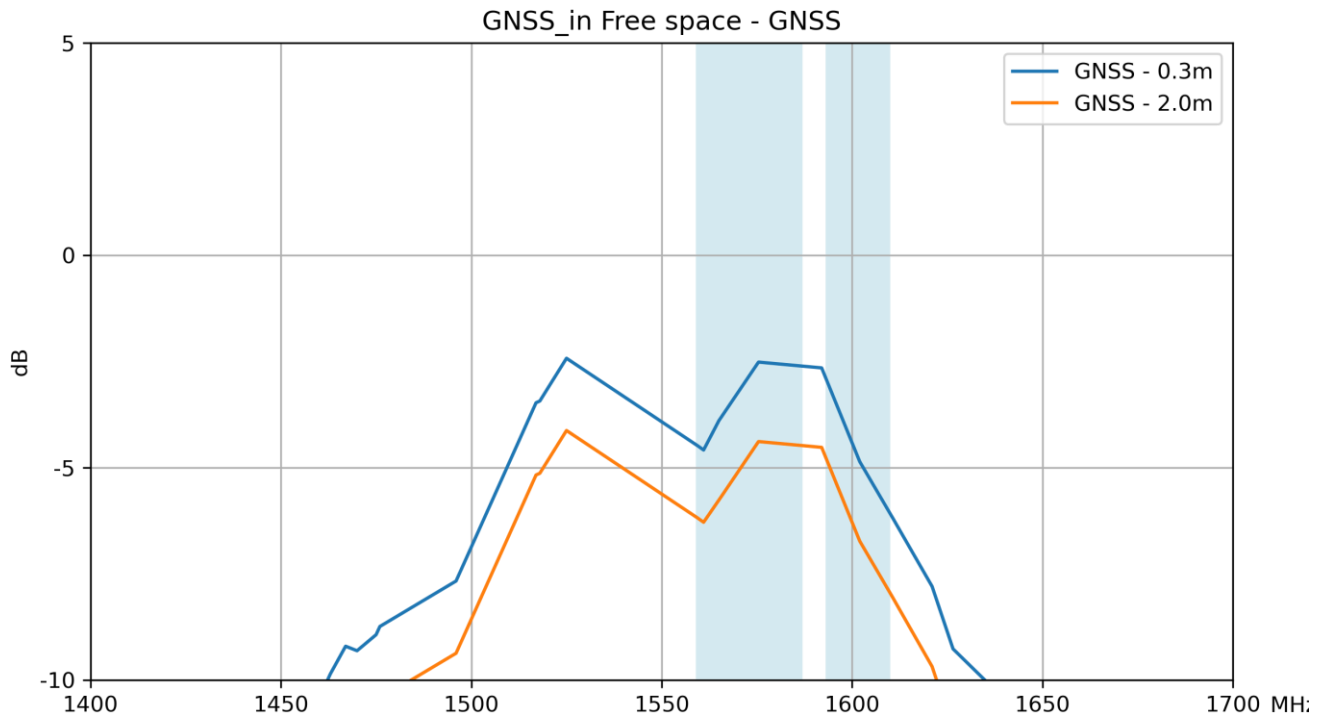

## 7.6 Peak Gain

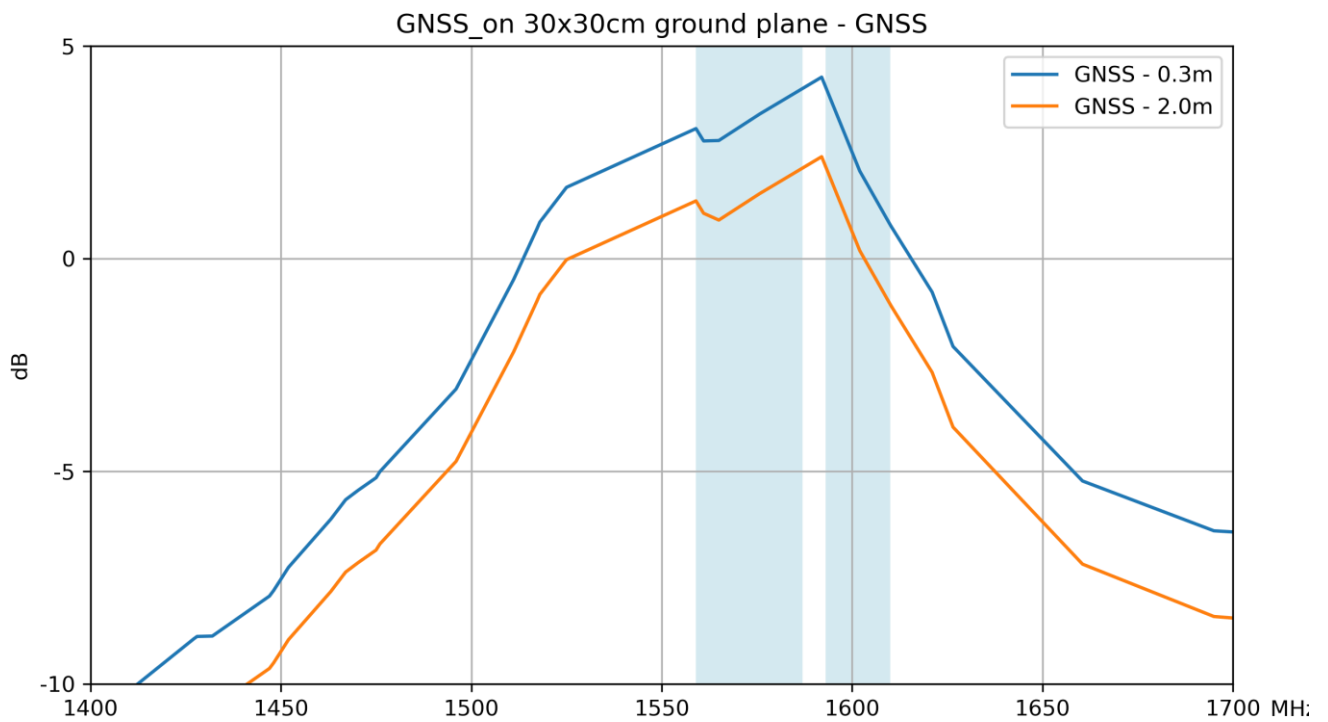
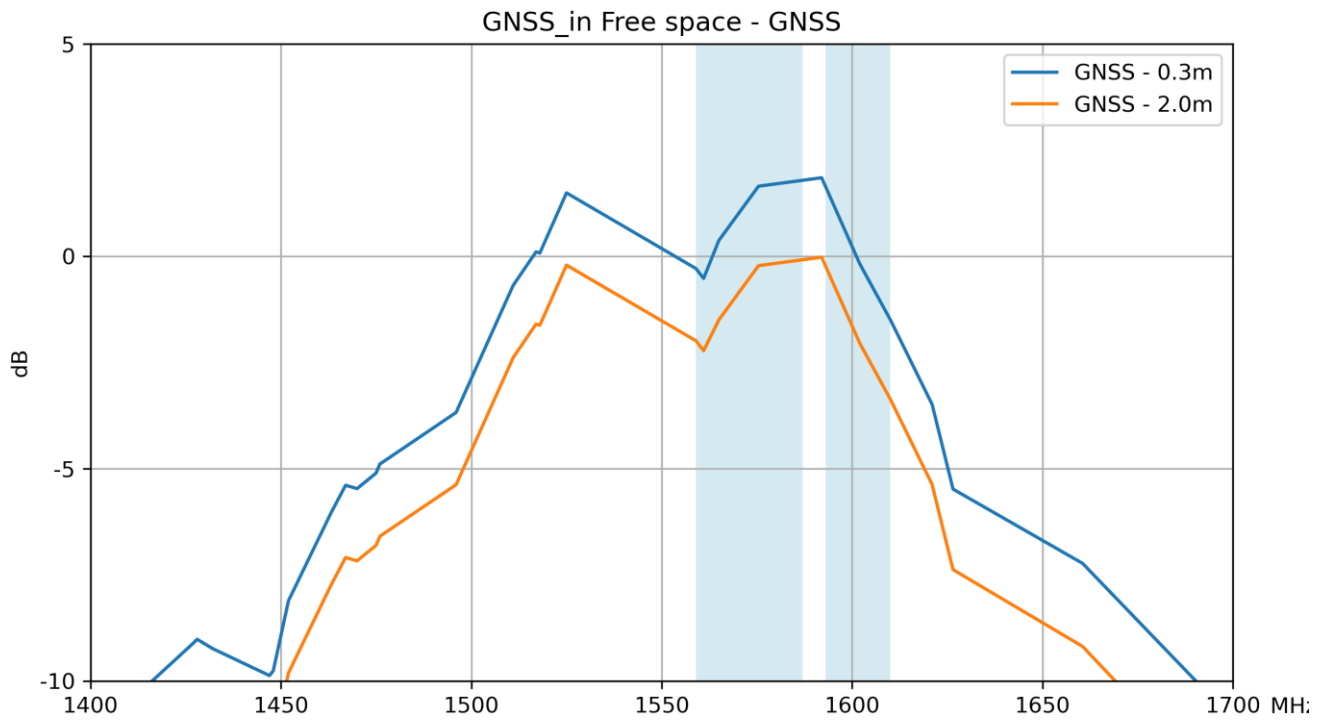

Changelog for the datasheet

**SPE-23-8-284- MA321.A.001**

<b>Revision: A (Original First Release)</b>	
Date:	2023-29-09
Notes:	
Author:	Cesar Sousa

**Previous Revisions**



[www.taoglas.com](http://www.taoglas.com)

