



TAOGLAS®



Datasheet

Comet Series

Part No:
MA323.A.001

Description

Comet 3-in-1 - 2*5G/4G MIMO & Wi-Fi Adhesive/Magnetic Mount Puck Antenna

Features:

Low-profile Housing with Adhesive/Magnetic Mount
2* 5G/4G MIMO 600-6000MHz
1*Wi-Fi 2.4GHz/5.8GHz/5.925-7.125GHz
Worldwide 5G Bands including legacy 4G 3G and 2G bands
IP67 Waterproof Enclosure
Dimensions: Ø80mm * 18.1mm
2m Low Loss TGC-1.5DS cable with SMA(M) & RP-SMA(M) connectors
Custom Cables and Connectors Available
RoHS & Reach Compliant

1.	Introduction	2
2.	Specification	3
3.	Antenna Characteristics	6
4.	Radiation Patterns	16
5.	Mechanical Drawing	65
6.	Packaging	66
7.	Application Note	67
<hr/>		
	Changelog	79

Taoglas makes no warranties based on the accuracy or completeness of the contents of this document and reserves the right to make changes to specifications and product descriptions at any time without notice. Taoglas reserves all rights to this document and the information contained herein. Reproduction, use or disclosure to third parties without express permission is strictly prohibited.



1. Introduction



The Taoglas Comet MA323 is a low profile, puck style, adhesive/magnetic mount 3-in-1 antenna. The MA323 contains two 5G/4G high performance antennas for use in MIMO cellular systems. Through innovative antenna design techniques, it covers all worldwide cellular frequencies from 600MHz to 6GHz, with stable gain and high efficiency, normally difficult to achieve in smaller antennas. It also contains a wideband Wi-Fi antenna covering newly established Wi-Fi 6/7 frequencies, along with the legacy 2.4/5.8GHz Wi-Fi and Bluetooth frequencies.

The Comet series has been designed to be compact and low profile, measuring just 80x18mm, to be utilized in application areas where other larger and taller antennas are not appropriate. The Comet has been designed with an option for either magnetic or adhesive mounting. This allows it to be utilized and installed in applications where destructive installations are not allowed, such as drilling mounting holes to secure a permanent antenna on leased vehicles.

Typical Applications Include:

- Telematics
- Gateways and Routers
- Digital Signage
- First Responder and Emergency Services

The robust ASA magnetic mount enclosure is designed to be waterproof rated to IP67 and can be mounted internally or externally on devices or vehicles. The Comet comes with a separate 3M foam high-performance pad for adhesive mount application. All connections utilize 2m TGC-1.5DS coaxial cable with SMA(M) & RP-SMA(M) connectors as standard. Customized cable and connector versions are also available.

Contact your regional Taoglas customer support team for further information.

2. Specification

LTE Electrical									
Band	Frequency (MHz)	Antenna	Efficiency (%)	Average Gain (dB)	Peak Gain (dBi)	Impedance	Polarization	Radiation Pattern	Max. input power
5G NR Band 71	617-698	LTE1 FS	48.3	-3.16	2.61	50 Ω	Linear	Omni	10W
		LTE2 FS	61.4	-2.12	3.87				
		LTE1 GP	37.5	-4.26	1.56				
		LTE2 GP	40.9	-3.88	1.89				
5G/4G/3G Band 12,13,14,17,28,29	698-824	LTE1 FS	58.3	-2.35	2.98				
		LTE2 FS	58.7	-2.32	3.23				
		LTE1 GP	32.2	-4.92	3.79				
		LTE2 GP	36.1	-4.43	2.81				
5G/4G/3G/ NB-IoT/Cat M Band 5,8,18,19,20,26, 27	824-960	LTE1 FS	51.5	-2.88	3.62				
		LTE2 FS	29.9	-5.25	2.34				
		LTE1 GP	38.1	-4.19	3.90				
		LTE2 GP	31.8	-4.98	3.97				
5G NR/4G Band 21,32,74,75,76	1427-1518	LTE1 FS	26.5	-5.77	0.50				
		LTE2 FS	12.9	-8.88	-1.62				
		LTE1 GP	25.4	-5.94	0.86				
		LTE2 GP	12.9	-8.90	-1.45				
5G/4G/3G Band 1,2,3,4,9,23,25,35, 39,66	1710-2200	LTE1 FS	47.1	-3.27	2.60				
		LTE2 FS	52.9	-2.77	2.82				
		LTE1 GP	29.2	-5.35	3.94				
		LTE2 GP	31.5	-5.02	5.23				
5G/4G/3G Band 7,30,38,40,41	2300-2690	LTE1 FS	37.0	-4.32	2.94				
		LTE2 FS	61.3	-2.13	5.17				
		LTE1 GP	34.5	-4.62	6.09				
		LTE2 GP	58.3	-2.34	5.60				
5G NR/4G Band 22,42,48,77,78,79	3300-4200	LTE1 FS	52.9	-2.76	4.25				
		LTE2 FS	62.4	-2.05	5.04				
		LTE1 GP	38.0	-4.20	3.97				
		LTE2 GP	47.4	-3.24	5.40				
5G NR N79	4400-5000	LTE1 FS	43.1	-3.65	4.95				
		LTE2 FS	41.9	-3.77	2.94				
		LTE1 GP	42.9	-3.68	4.83				
		LTE2 GP	44.8	-3.49	6.62				
LTE5200	5150-5925	LTE1 FS	38.5	-4.15	3.87				
		LTE2 FS	55.9	-2.52	4.28				
		LTE1 GP	36.7	-4.36	5.82				
		LTE2 GP	55.9	-2.52	7.76				

*FS = Free Space

*GP = Ground Plane(30x30cm)

5G/4G Bands				
Band Number	5GNR / FR1 / LTE / LTE-Advanced / WCDMA / HSPA / HSPA+ / TD-SCDMA			
	Uplink	Downlink	FS LTE 1	FS LTE 2
B1	1920 to 1980	2110 to 2170	✓	✓
B2	1850 to 1910	1930 to 1990	✓	✓
B3	1710 to 1785	1805 to 1880	✓	✓
B4	1710 to 1755	2110 to 2155	✓	✓
B5	824 to 849	869 to 894	✓	✓
B7	2500 to 2570	2620 to 2690	✓	✓
B8	880 to 915	925 to 960	✓	✓
B9*	1749.9 to 1784.9	1844.9 to 1879.9	✓	✓
B11	1427.9 to 1447.9	1475.9 to 1495.9	✓	✓
B12	699 to 716	729 to 746	✓	✓
B13	777 to 787	746 to 756	✓	✓
B14	788 to 798	758 to 768	✓	✓
B17	704 to 716	734 to 746	✓	✓
B18	815 to 830	860 to 875	✓	✓
B19	830 to 845	875 to 890	✓	✓
B20	832 to 862	791 to 821	✓	✓
B21	1447.9 to 1462.9	1495.9 to 1510.9	✓	✓
B22*	3410 to 3490	3510 to 3590	✓	✓
B23*	2000 to 2020	2180 to 2200	✓	✓
B24	1626.5 to 1660.5	1525 to 1559	✓	✓
B25	1850 to 1915	1930 to 1995	✓	✓
B26	814 to 849	859 to 894	✓	✓
B27*	807 to 824	852 to 869	✓	✓
B28	703 to 748	758 to 803	✓	✓
B29		717 to 728	✓	✓
B30	2305 to 2315	2350 to 2360	✓	✓
B31	452.5 to 457.5	462.5 to 467.5	✗	✗
B32		1452 to 1496	✓	✓
B34		2010 to 2025	✓	✓
B35		1850 to 1910	✓	✓
B36		1930 to 1990	✓	✓
B37		1910 to 1930	✓	✓
B38		2570 to 2620	✓	✓
B39		1880 to 1920	✓	✓
B40		2300 to 2400	✓	✓
B41		2496 to 2690	✓	✓
B42		3400 to 3600	✓	✓
B43		3600 to 3800	✓	✓
B45		1447 to 1467	✓	✓
B46		5150 to 5925	✓	✓
B47		5855 to 5925	✓	✓
B48		3550 to 3700	✓	✓
B49		3550 to 3700	✓	✓
B50		1432 to 1517	✓	✓
B51		1427 to 1432	✗	✗
B52		3300 to 3400	✓	✓
B53		2483.5 to 2495	✓	✓
B65	1920 to 2010	2110 to 2200	✓	✓
B66	1710 to 1780	2110 to 2200	✓	✓
B68	698 to 728	753 to 783	✓	✓
B69		2570 to 2620	✓	✓
B70	1695 to 1710	1995 to 2020	✓	✓
B71	663 to 698	617 to 652	✓	✓
B72	451 to 456	461 to 466	✗	✗
B73	450 to 455	460 to 465	✗	✗
B74	1427 to 1470	1475 to 1518	✓	✓

5G/4G Bands				
Band Number	5G NR / FR1 / LTE / LTE-Advanced / WCDMA / HSPA / HSPA+ / TD-SCDMA			
B75	1432 to 1517			✓
B76	1427 to 1432			✓
B77	3300 to 4200			✓
B78	3300 to 3800			✓
B79	4400 to 5000			✓
B85	698 to 716	728 to 746		✓
B87	410 to 415	420 to 425		✗
B88	412 to 417	422 to 427		✗

Wi-Fi Electrical									
Band	Frequency (MHz)	Test Setup	Efficiency (%)	Average Gain (dB)	Peak Gain (dBi)	Impedance	Polarization	Radiation Pattern	Max. input power
2.4GHz	2400-2500	FS	47.1	-3.27	2.83	50 Ω	Linear	Omni	10W
		GP	36.1	-4.43	1.90				
5.8GHz	4900-5850	FS	63.2	-2.00	5.92				
		GP	63.8	-1.95	7.74				
6.175GHz	5925-6425	FS	60.6	-2.18	5.17				
		GP	49.5	-3.05	5.95				
6.475GHz	6425-6525	FS	60.0	-2.22	5.17				
		GP	51.5	-2.88	5.97				
6.7GHz	6525-6875	FS	61.3	-2.13	5.24				
		GP	53.4	-2.72	6.79				
7GHz	6875-7125	FS	61.5	-2.11	5.18				
		GP	53.3	-2.73	7.00				

*FS = Free Space

*GP = Ground Plane(30x30cm)

Mechanical	
Dimensions	80 mm Dia. X H18.01 mm
Weight	TBD
Material	ASA
Connector	LTE: SMA (M)ST , Wi-Fi: RP-SMA (M)ST
Cable	2m 1.5DS

Environmental	
Waterproof Rating	IP67
Temperature Range	-40°C to 85°C
Humidity	Non-condensing 65°C 95%RH

3. Antenna Characteristics

3.1 Test Setup – S11/VSWR/Return Loss

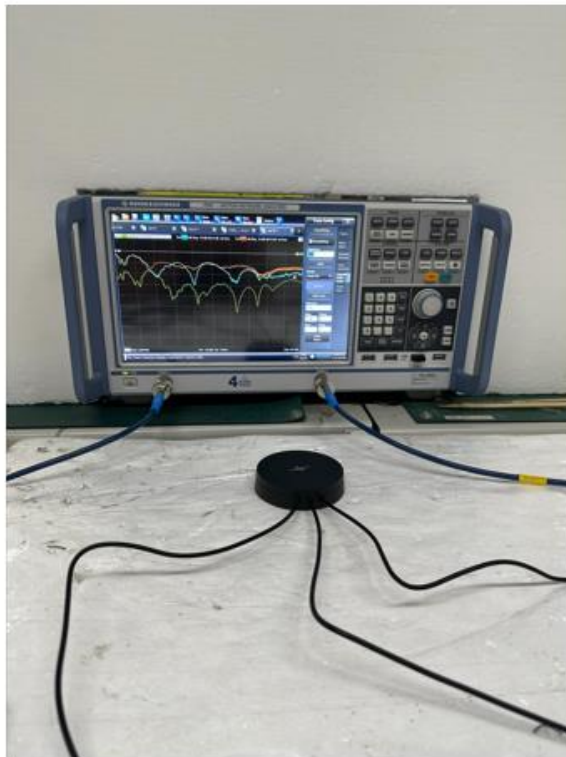
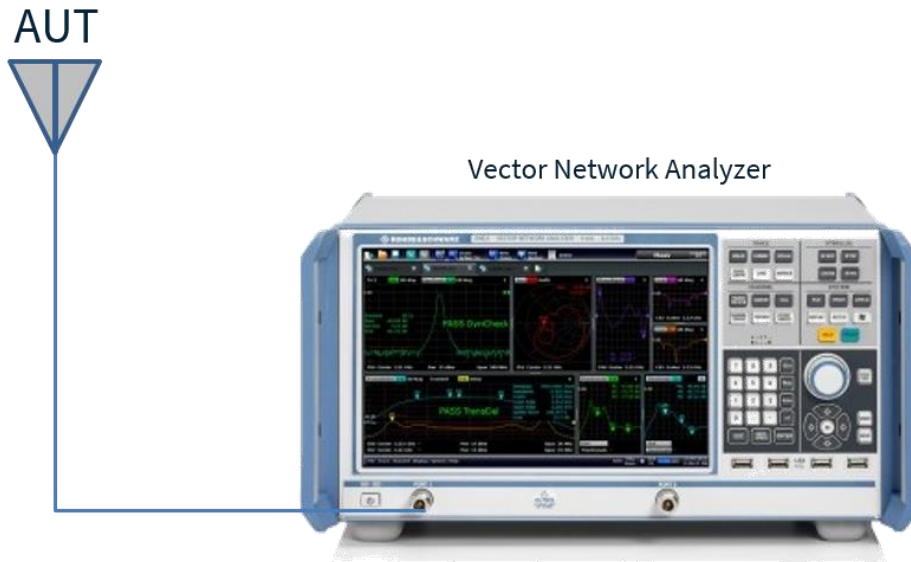

Free Space

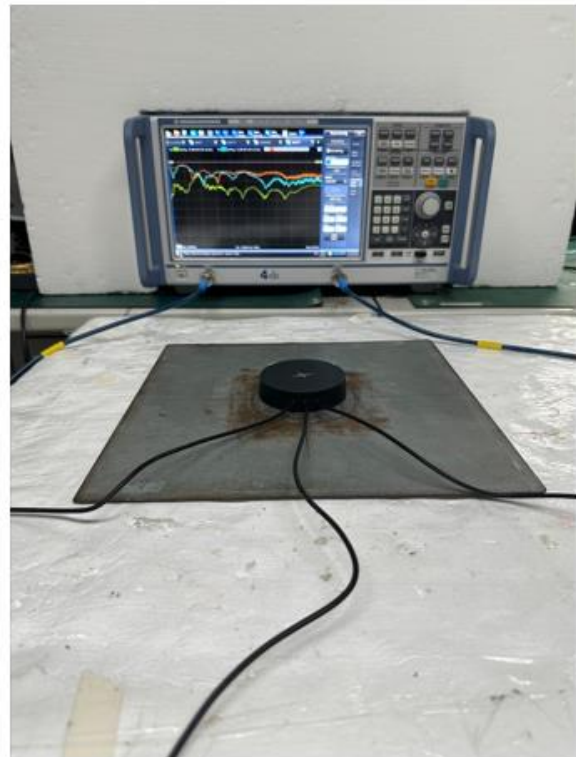

30x30cm Ground Plane

3.2 Test Setup – Isolation

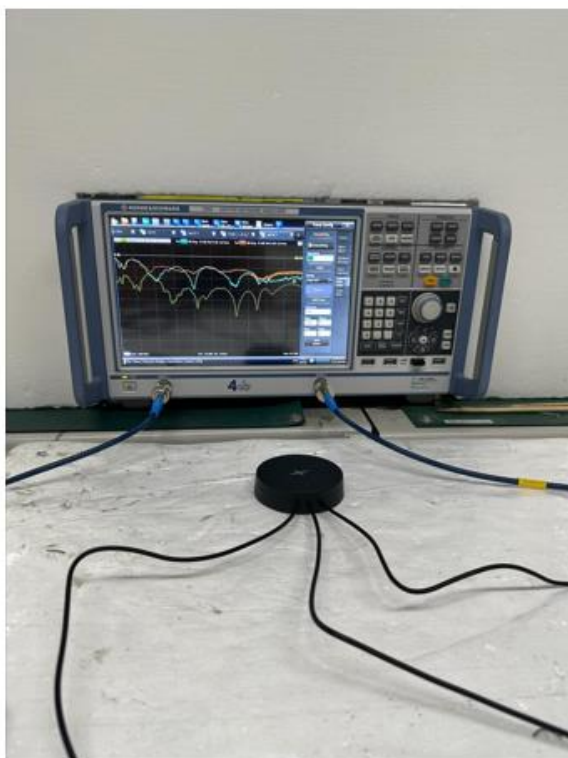
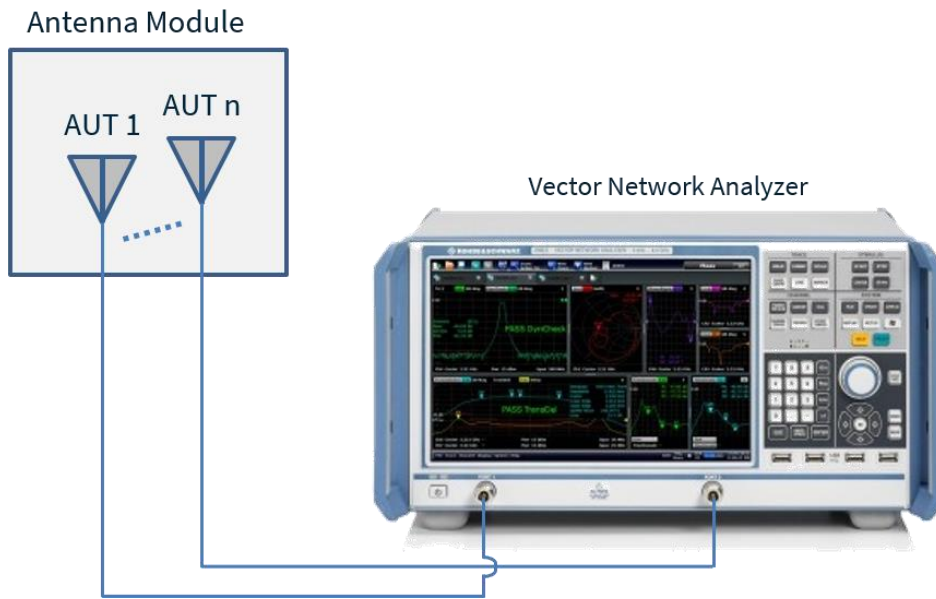

Free Space

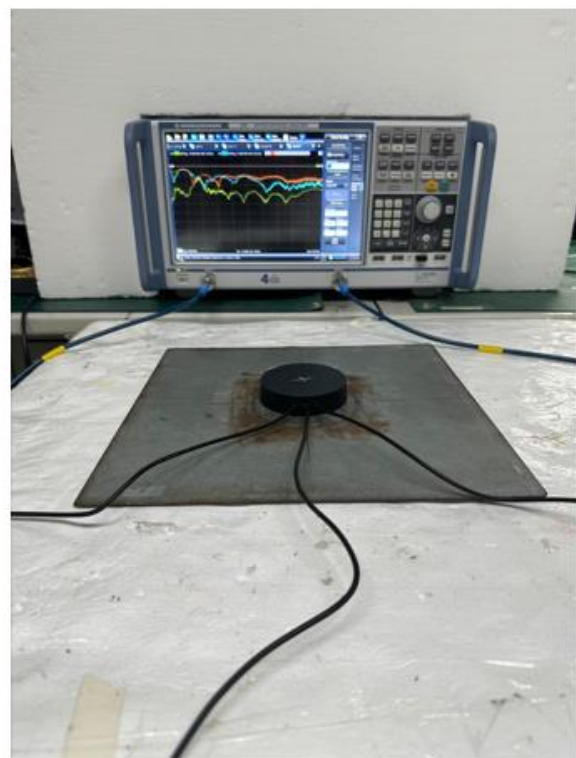

30x30cm Ground Plane

3.3 LTE - Return Loss

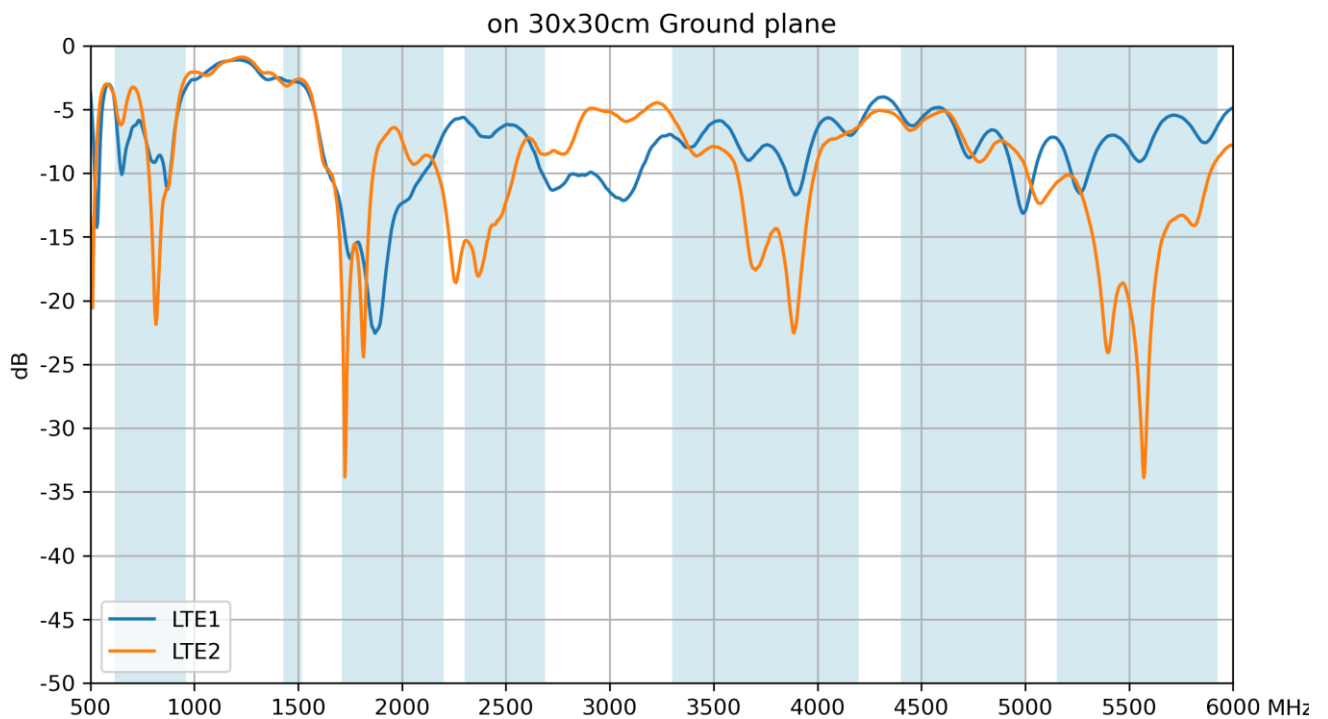
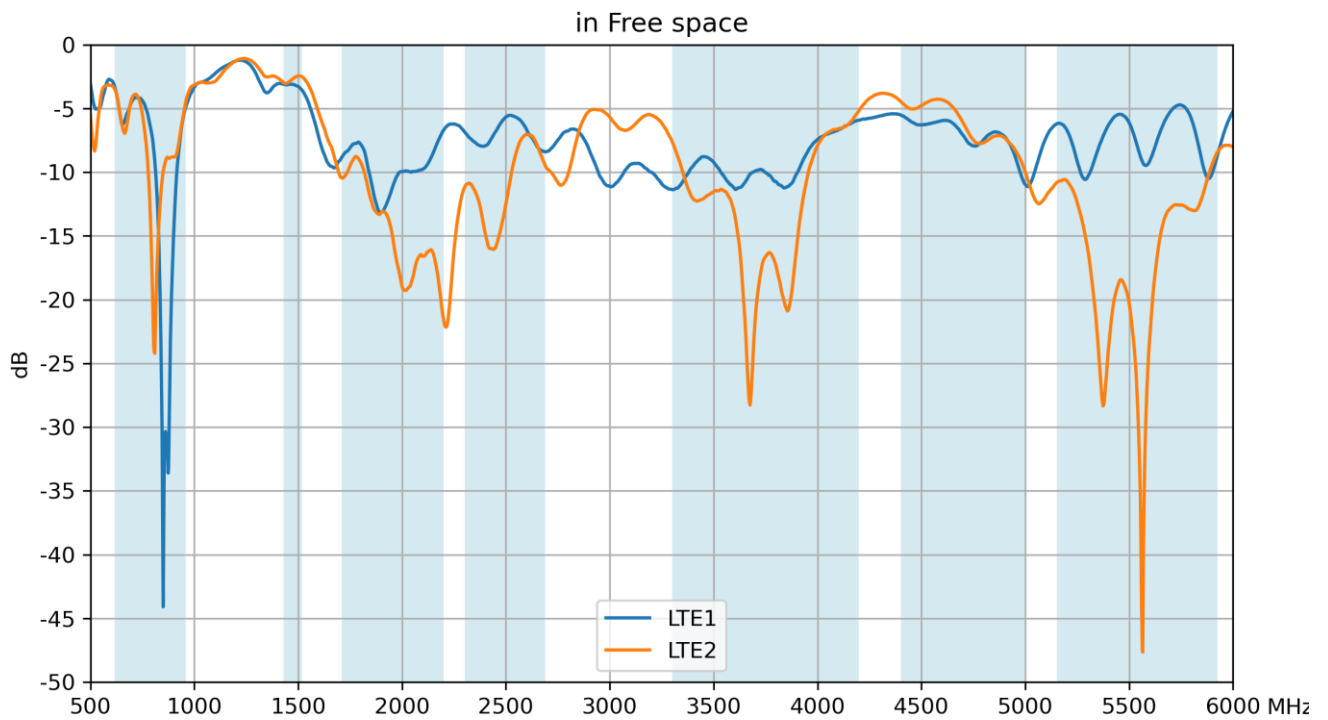

3.4 Wi-Fi – Return Loss

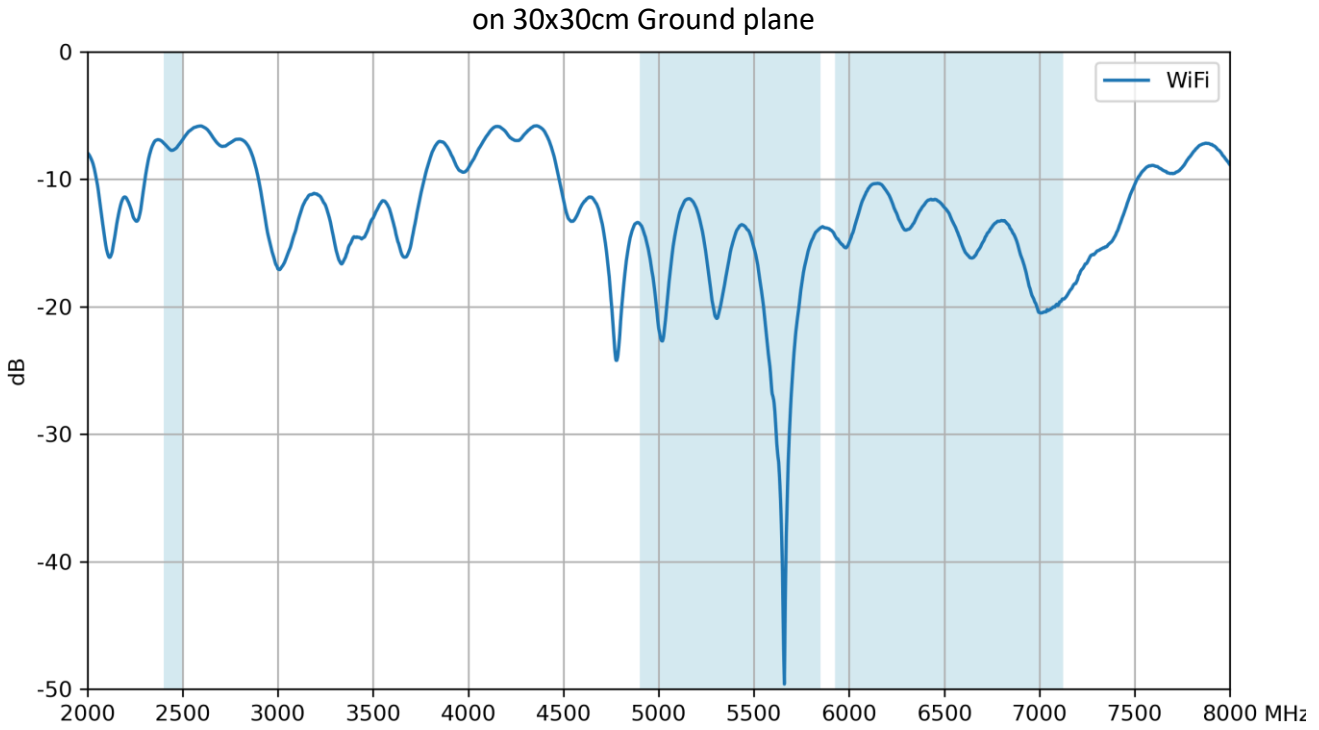
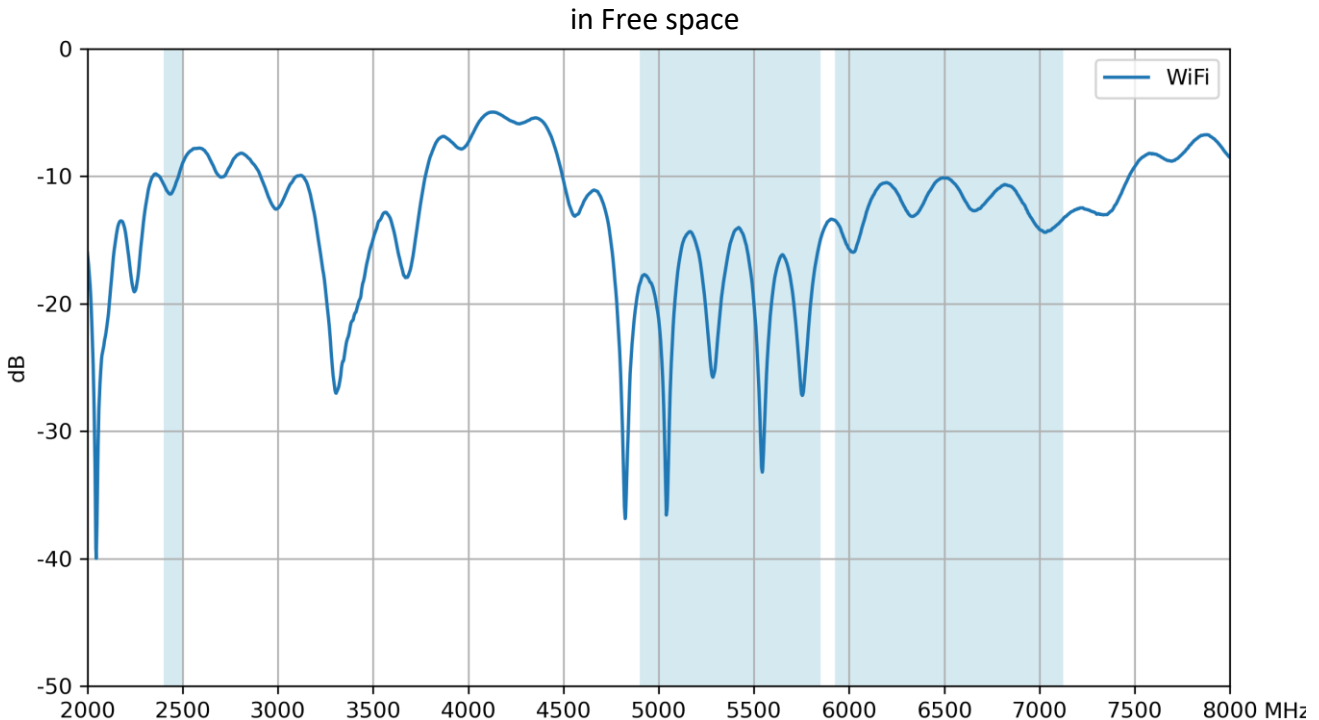

3.5 LTE - Efficiency

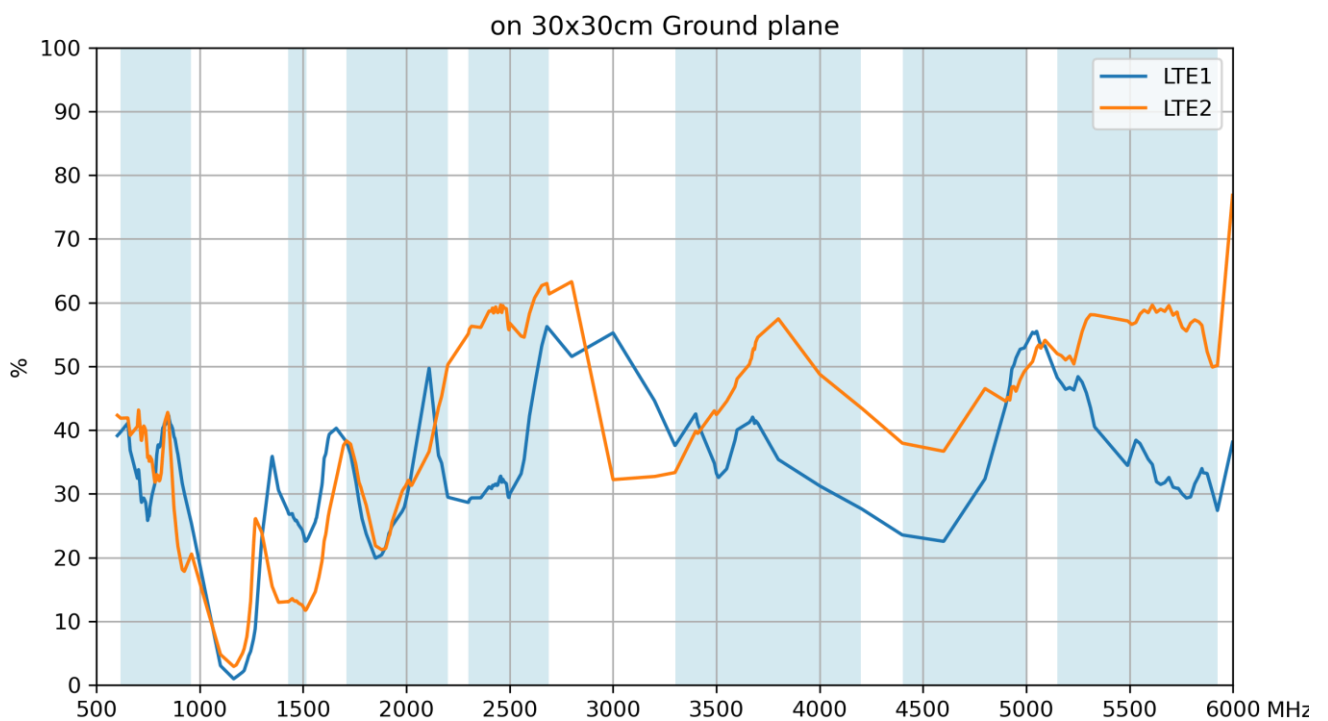
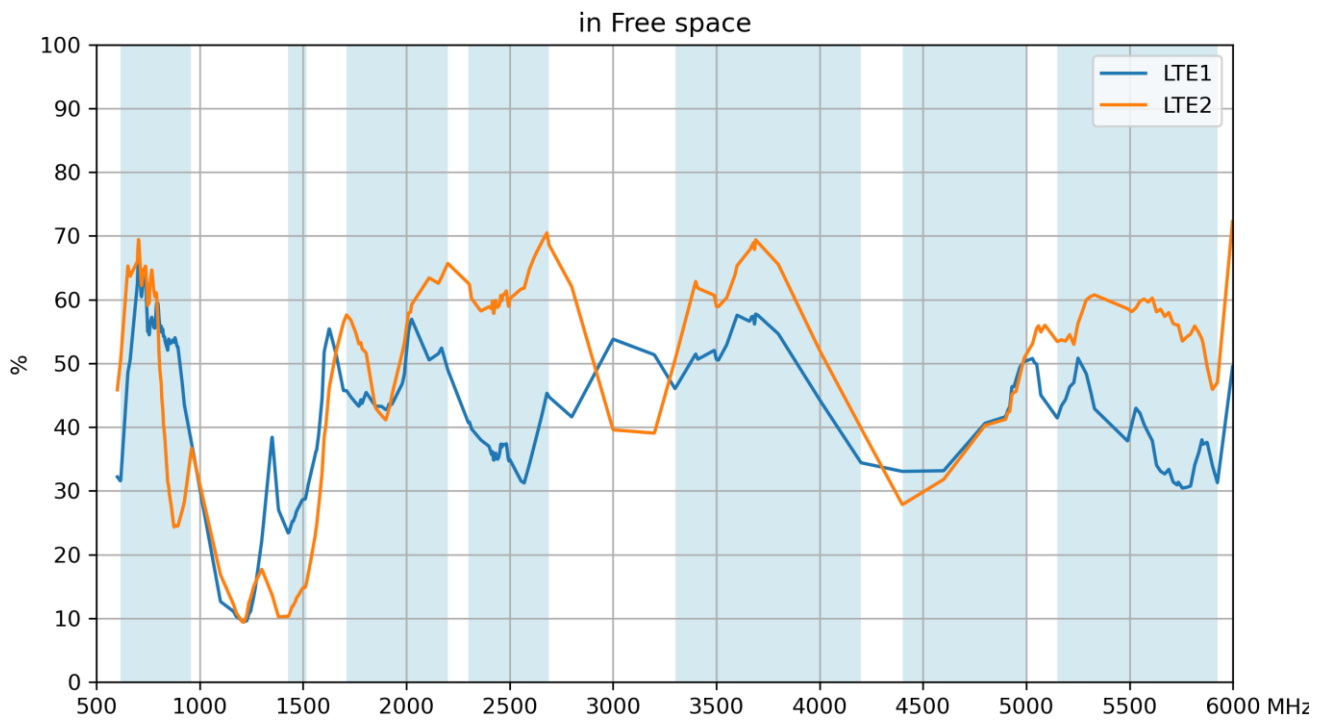

3.6 Wi-Fi- Efficiency

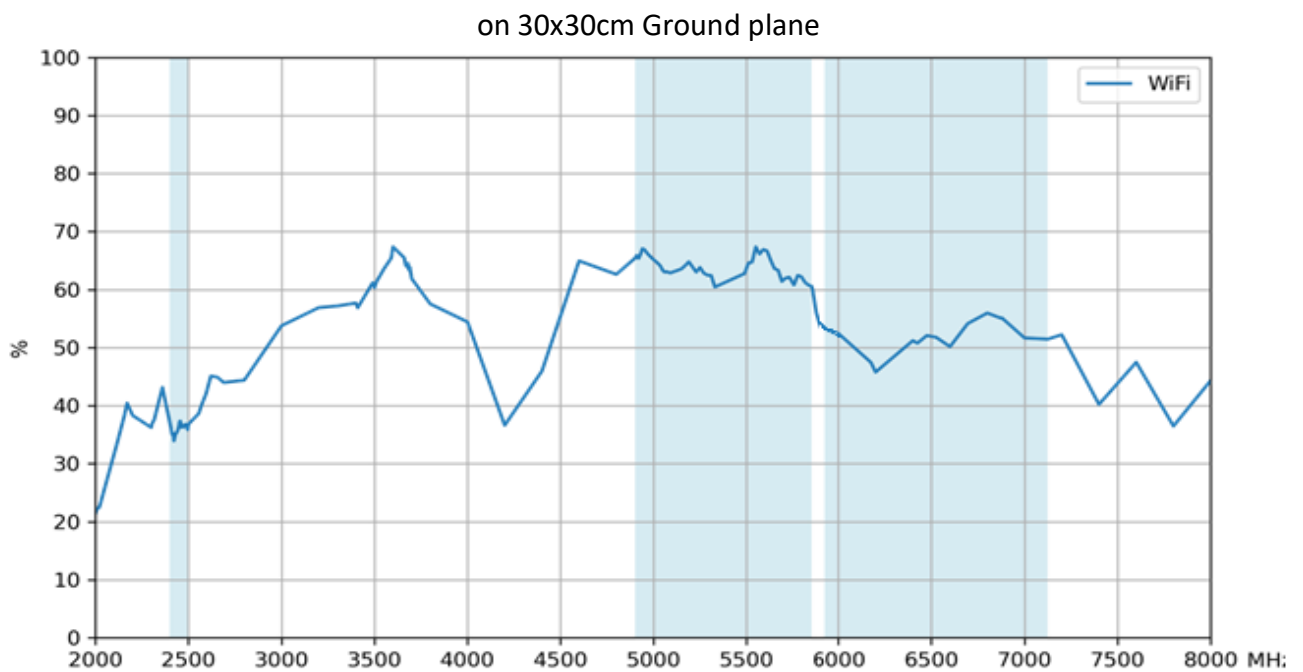
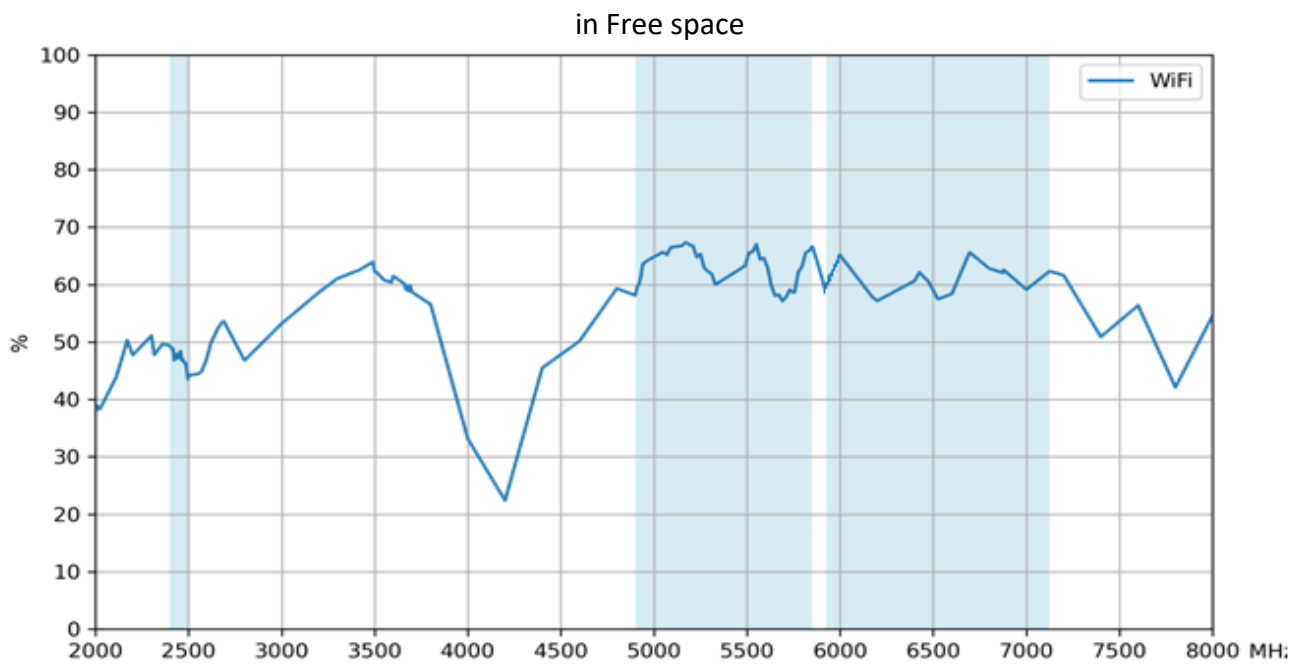

3.7 LTE - Average Gain

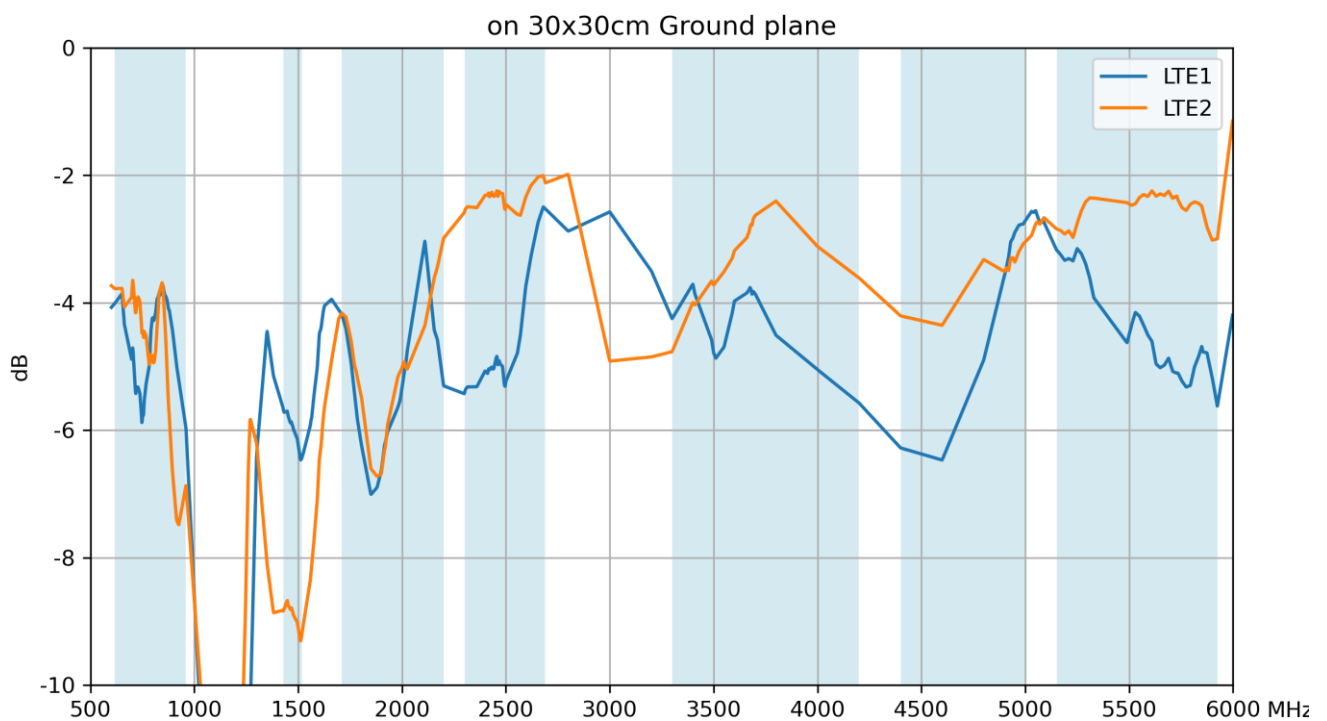
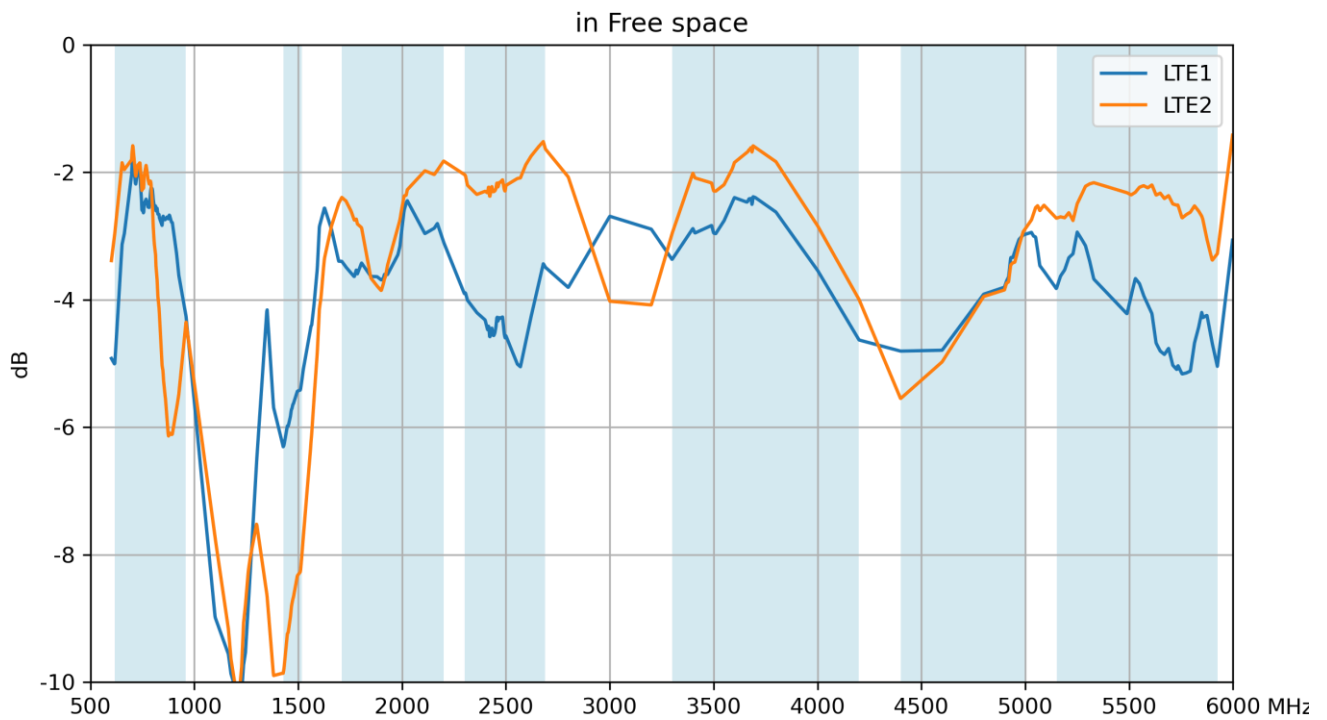

3.8 Wi-Fi - Average Gain

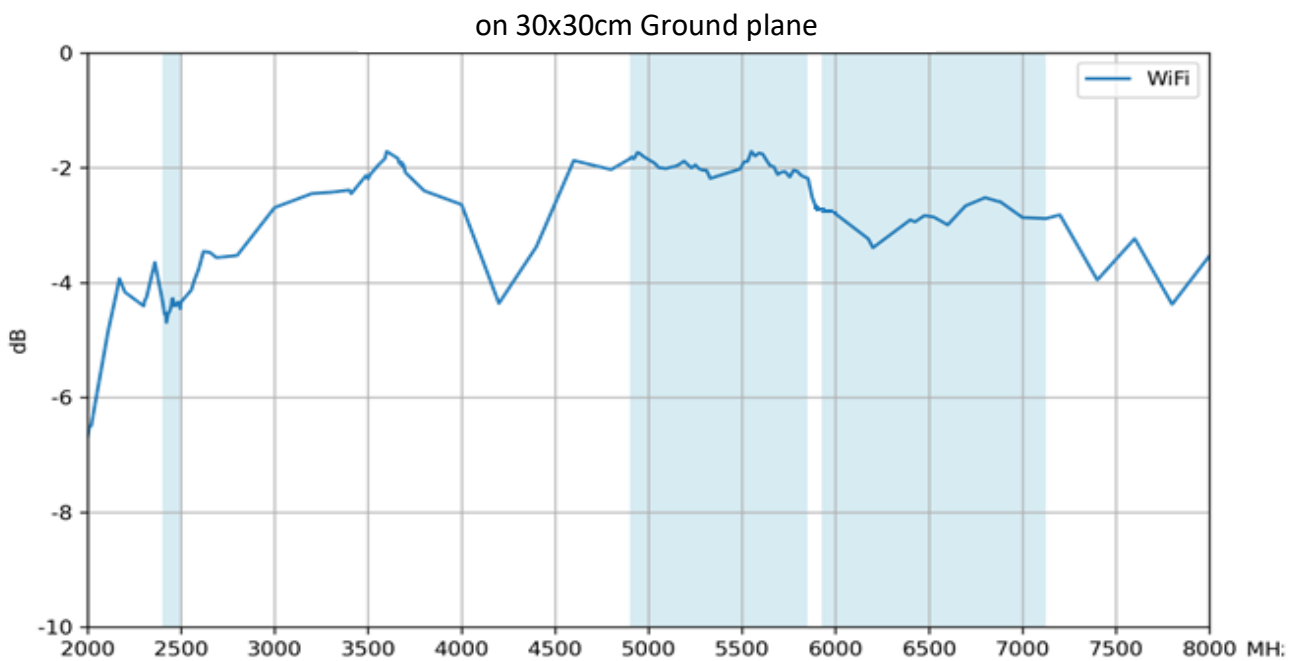
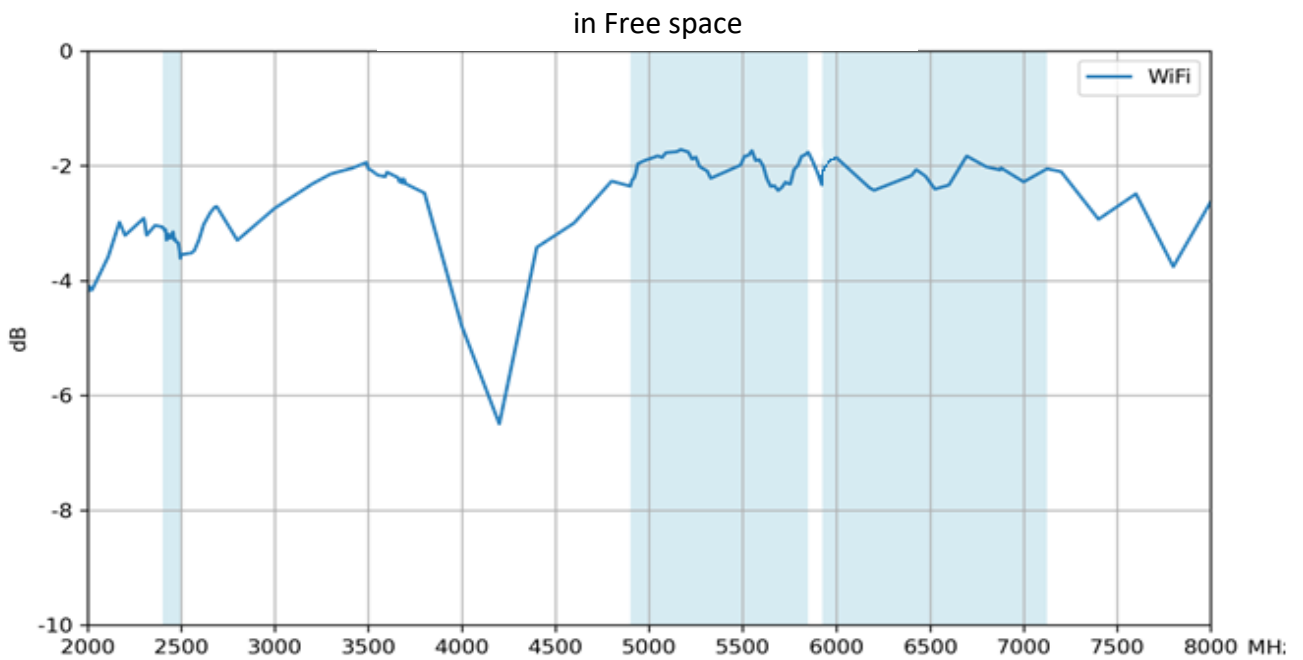

3.9 LTE - Peak Gain

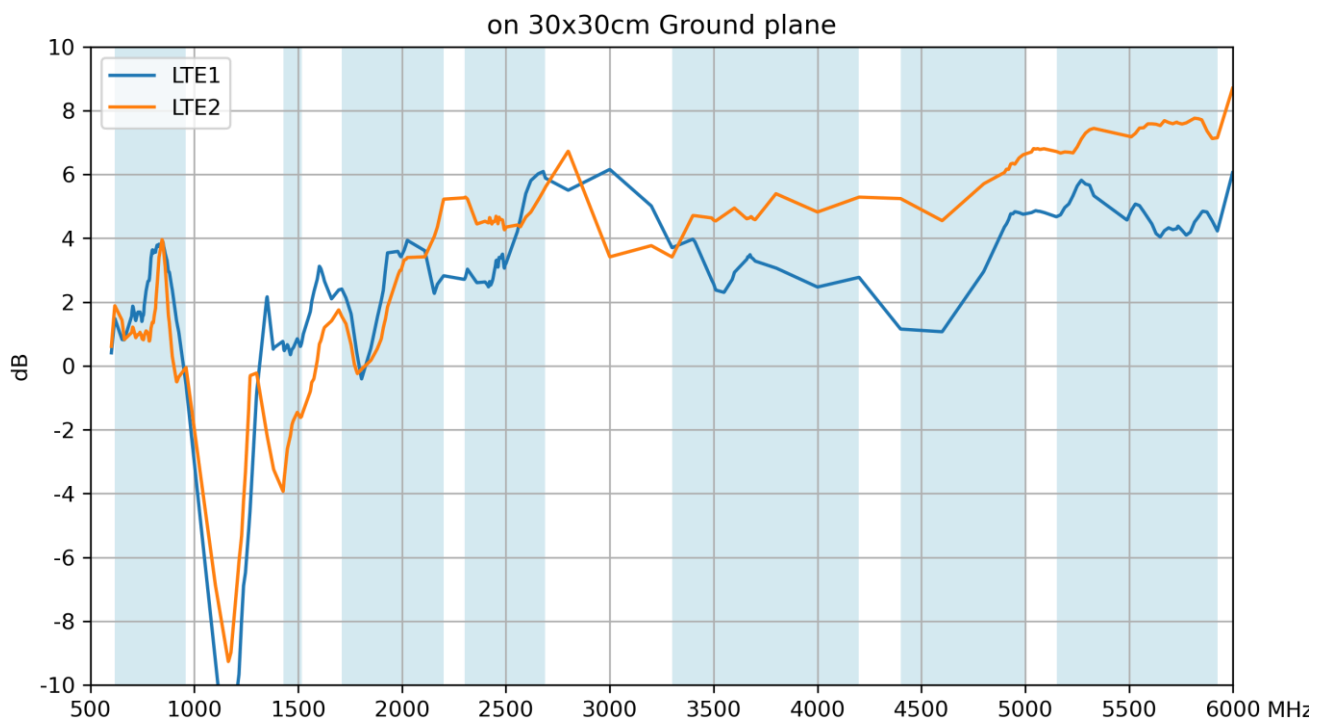
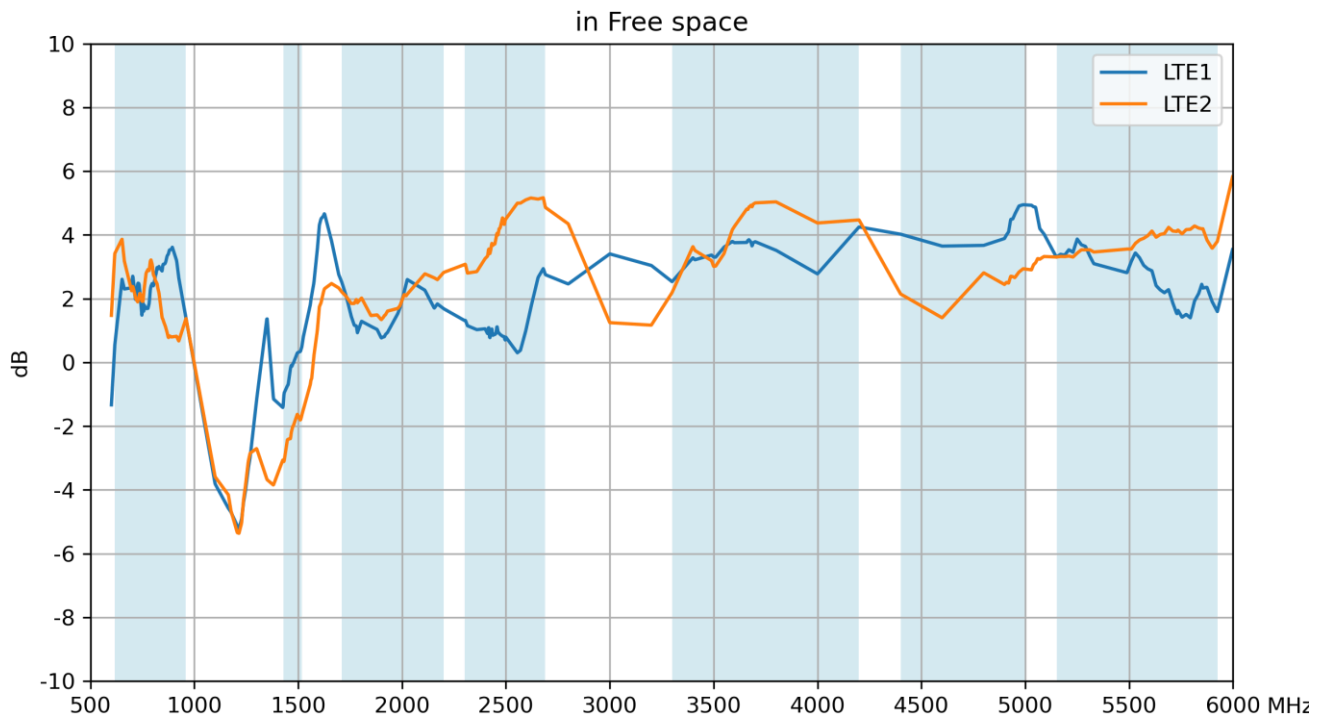

3.10 Wi-Fi - Peak Gain

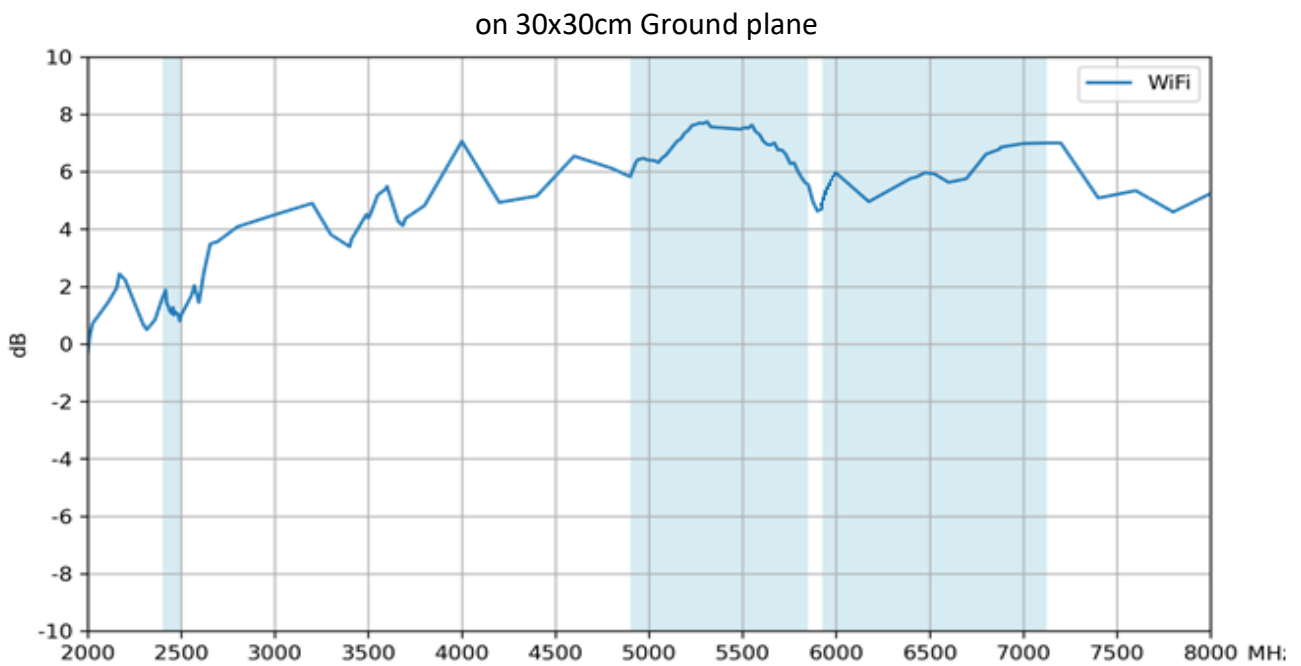
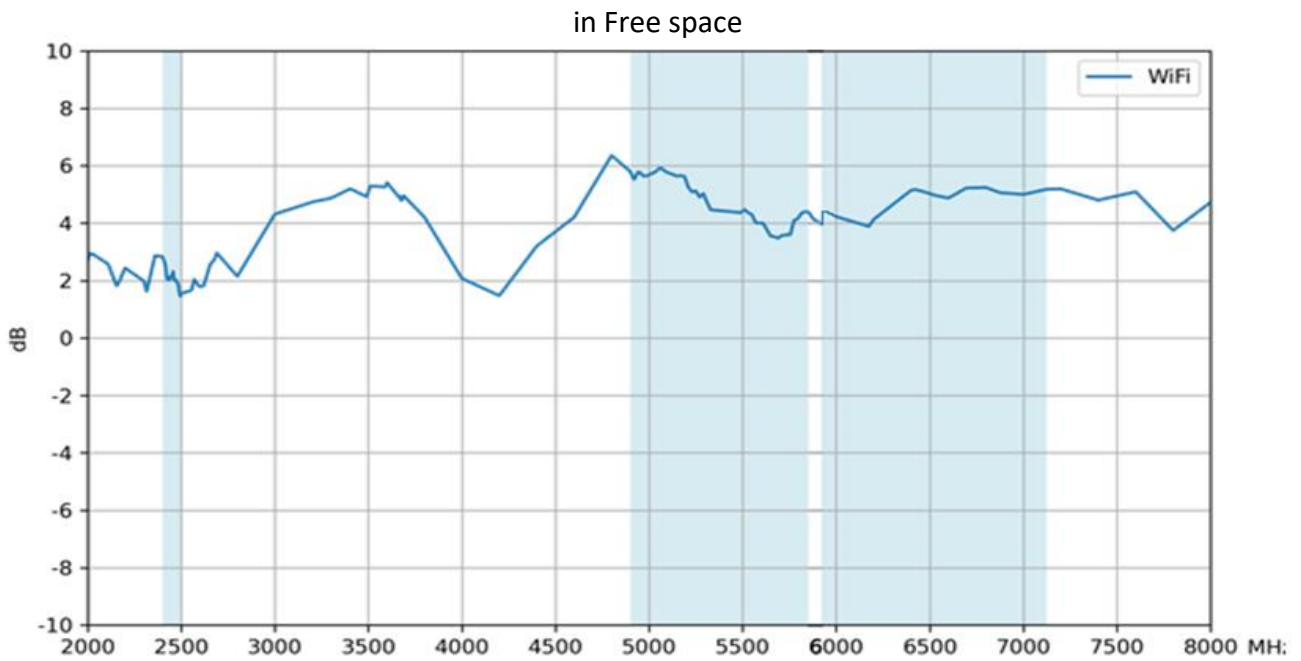

4. Radiation Patterns

4.1 Test Setup

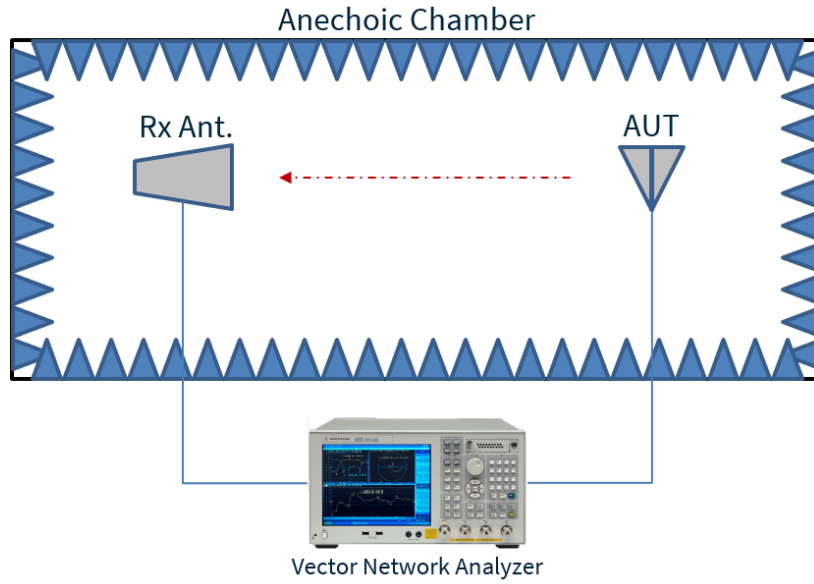

Free Space



30x30cm Ground Plane

4.2 LTE 1 in Free Space - Patterns at 652 MHz

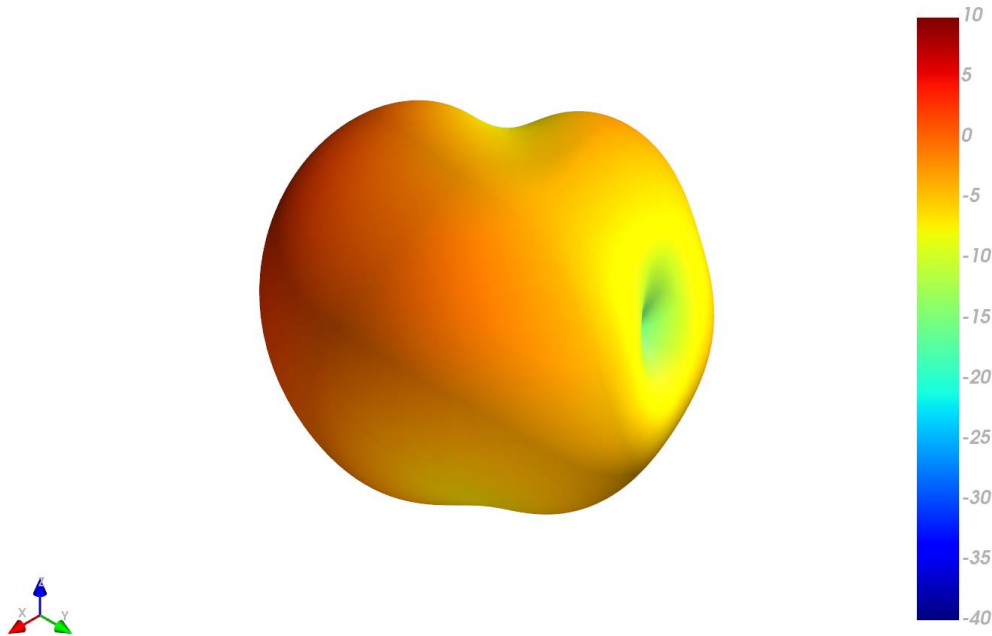

XZ Plane YZ Plane XY Plane

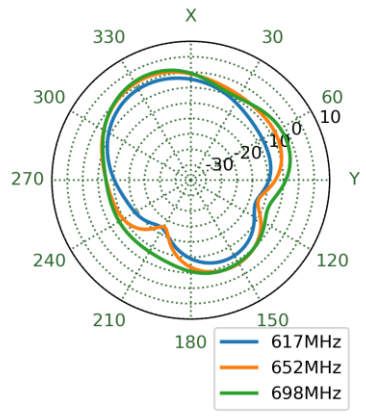
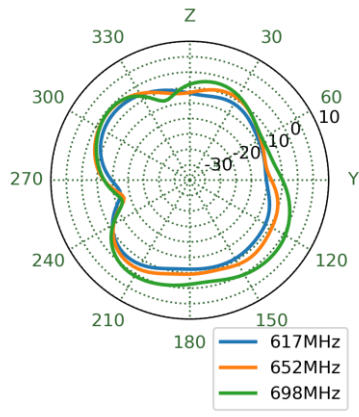
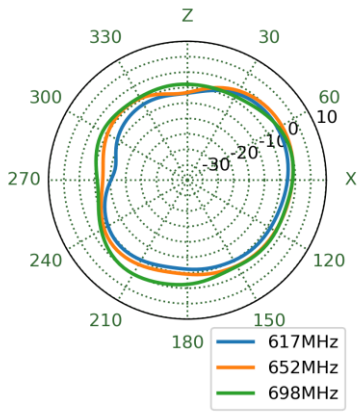

4.3 LTE 1 in Free Space - Patterns at 751 MHz

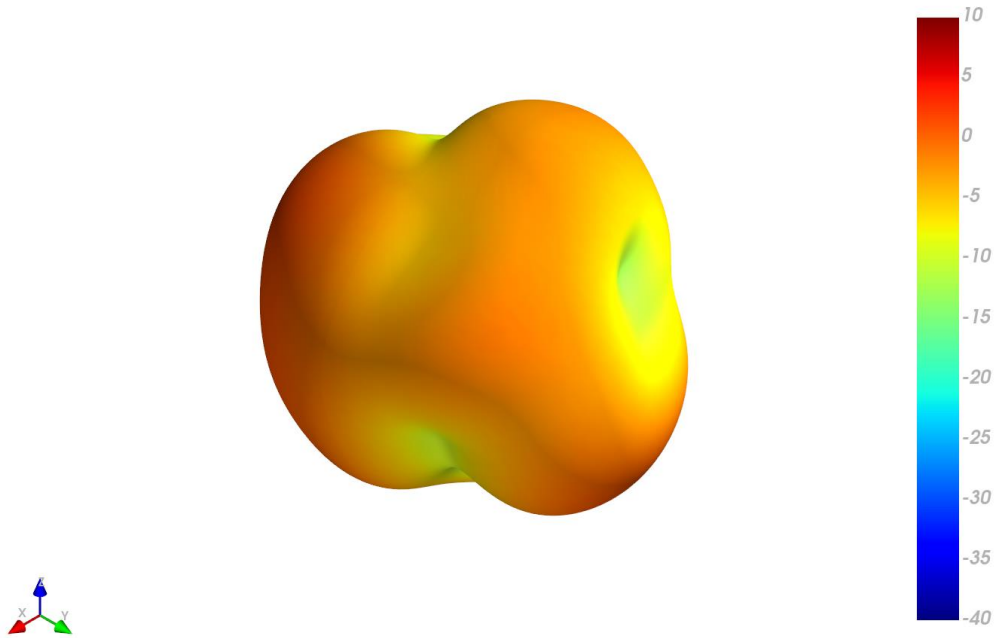

XZ Plane YZ Plane XY Plane

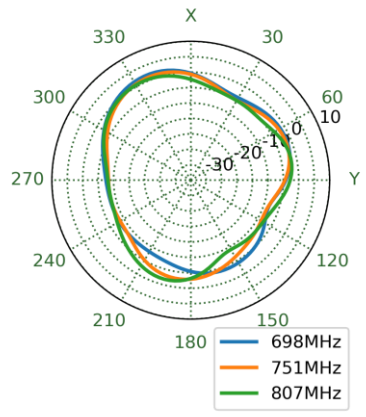
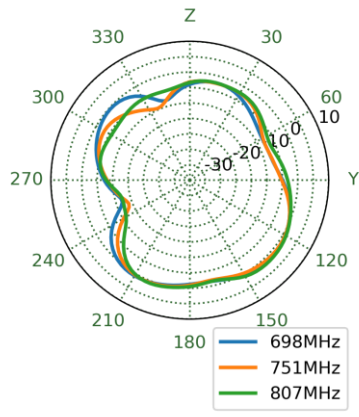
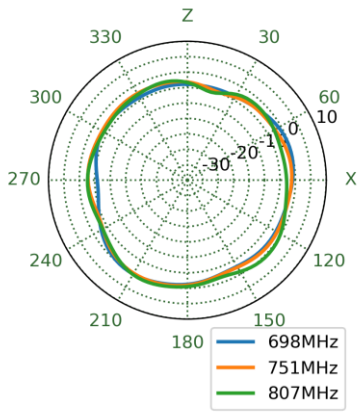

4.4 LTE 1 in Free Space - Patterns at 890 MHz

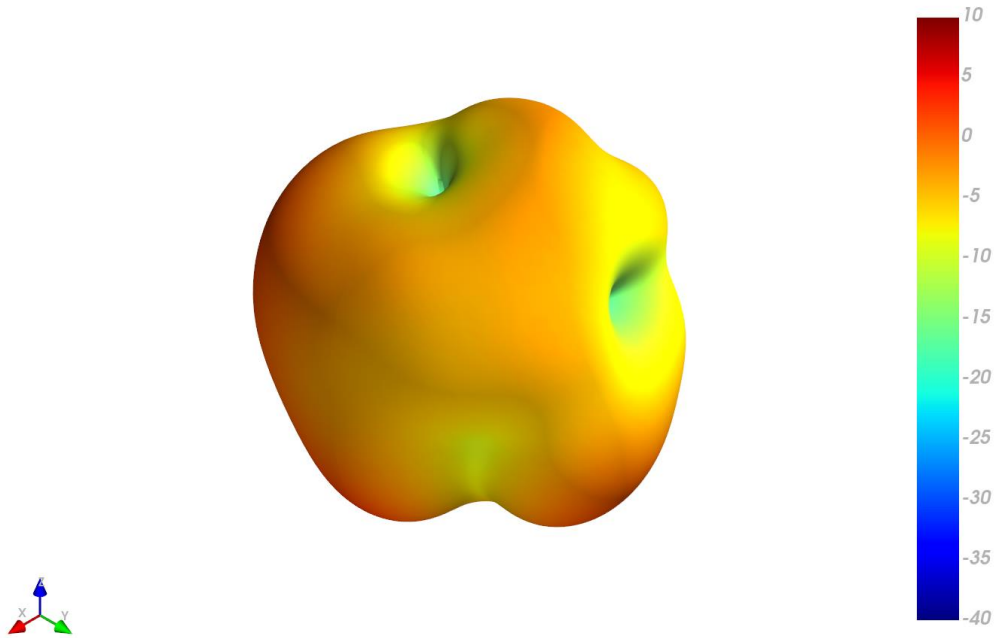

XZ Plane YZ Plane XY Plane

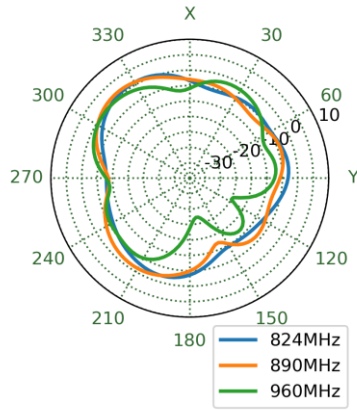
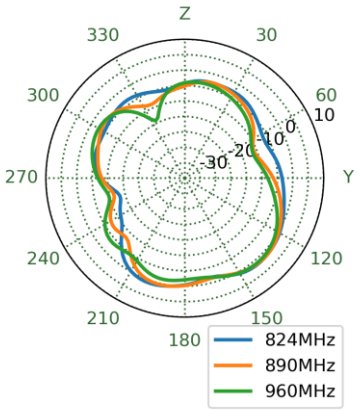
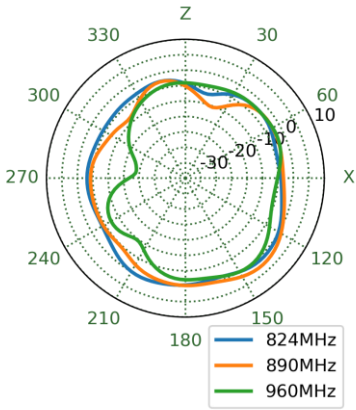

4.5 LTE 1 in Free Space - Patterns at 1470 MHz

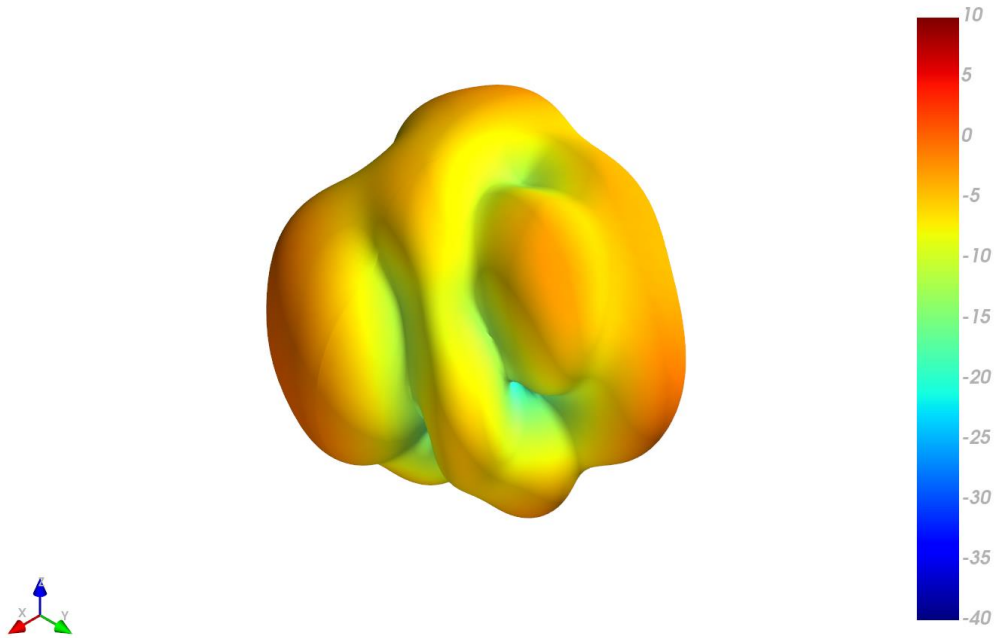

XZ Plane YZ Plane XY Plane

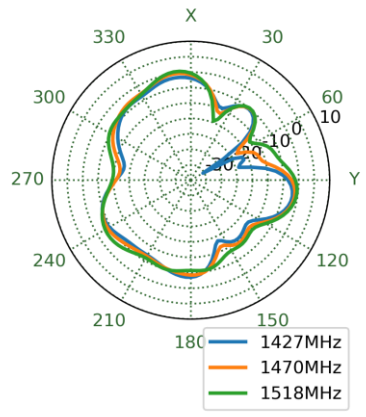
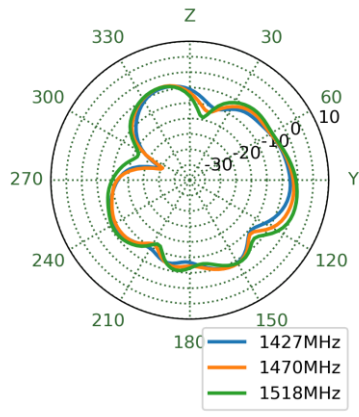
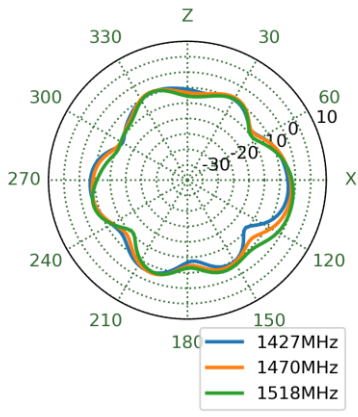

4.6 LTE 1 in Free Space - Patterns at 1805 MHz

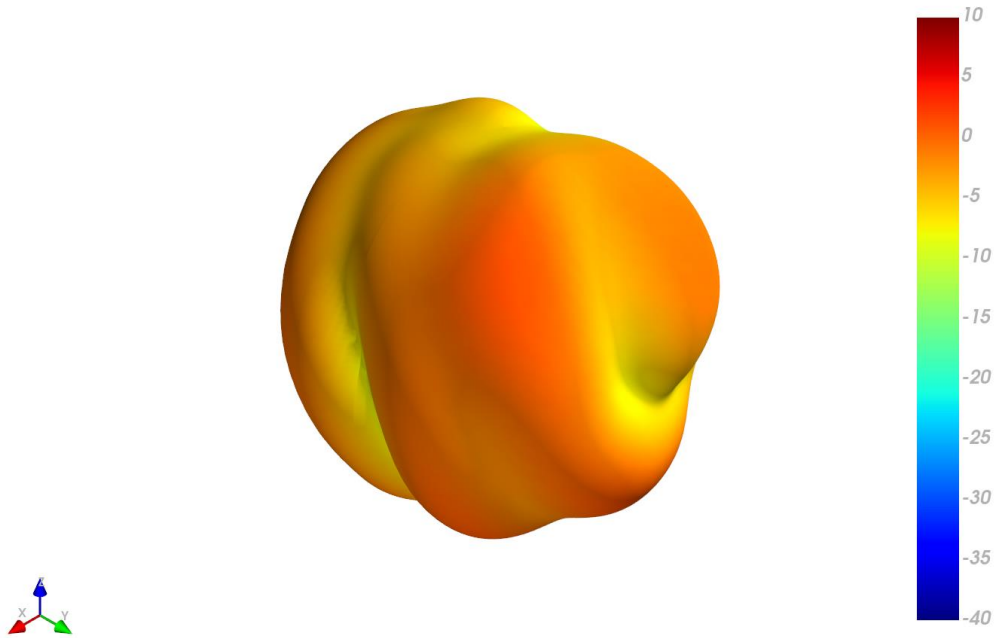

XZ Plane YZ Plane XY Plane

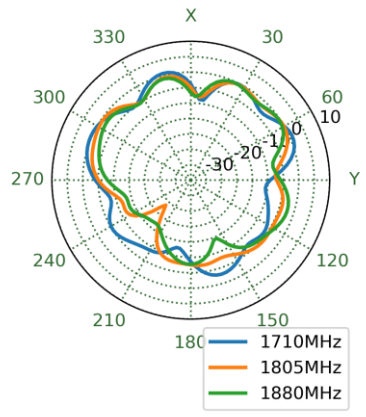
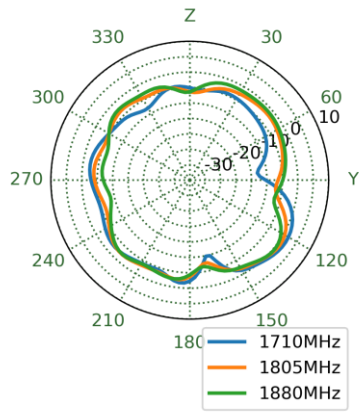
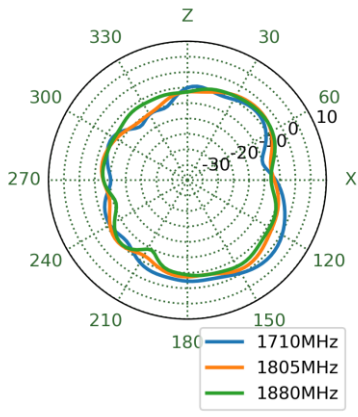

4.7 LTE 1 in Free Space - Patterns at 1920 MHz

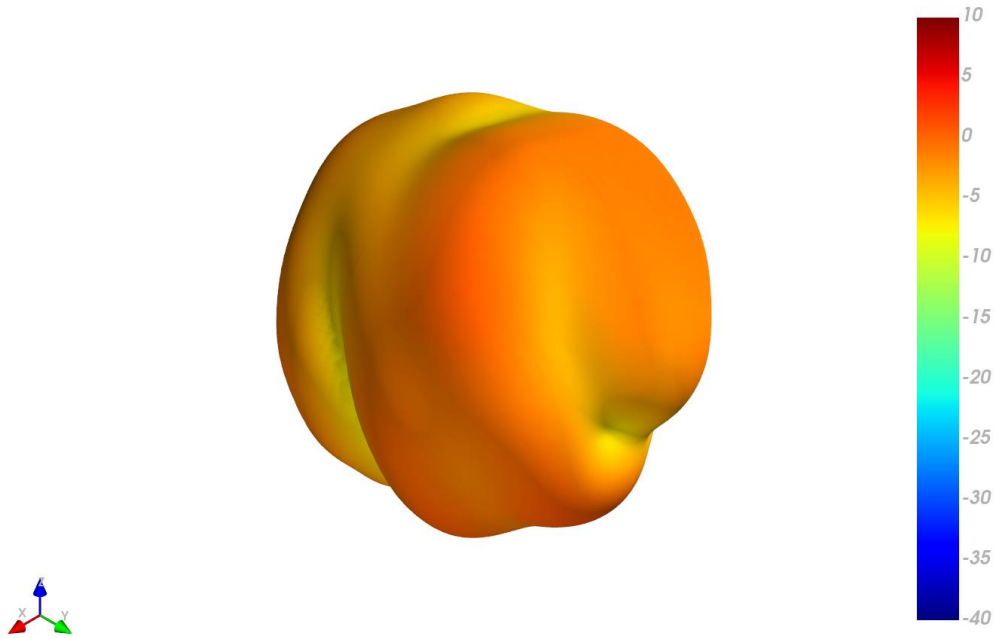

XZ Plane YZ Plane XY Plane

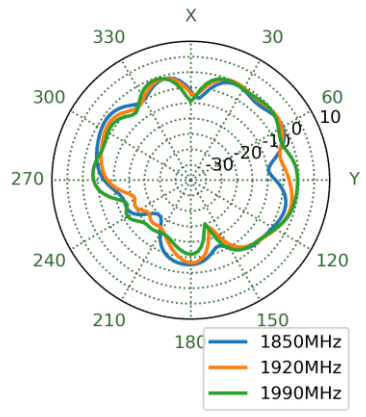
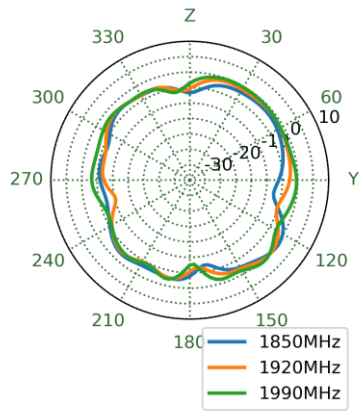
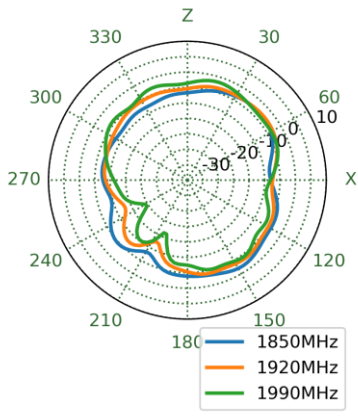

4.8 LTE 1 in Free Space - Patterns at 1990 MHz

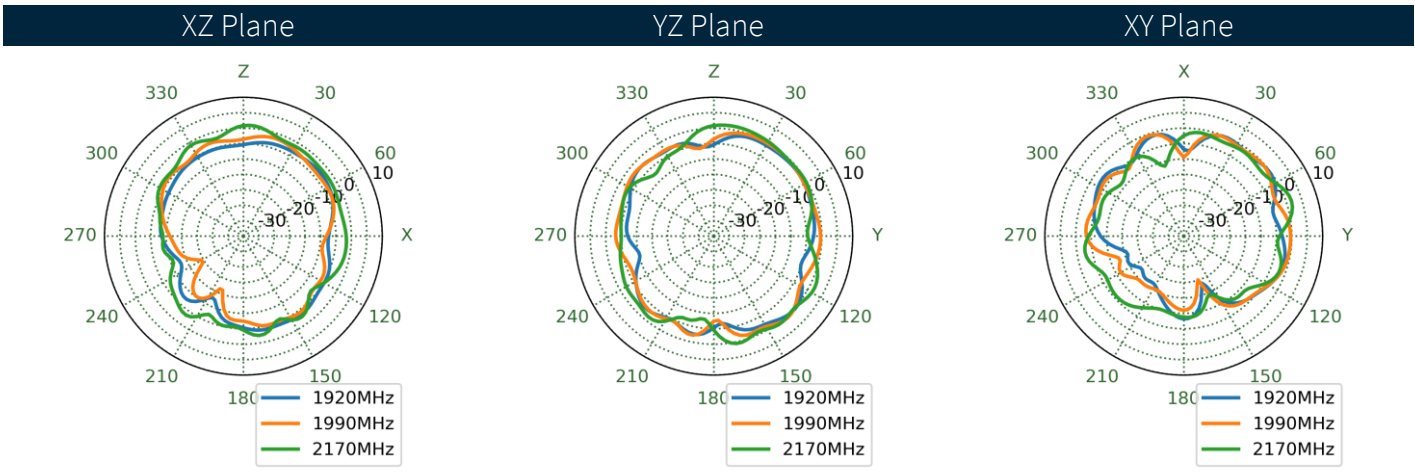
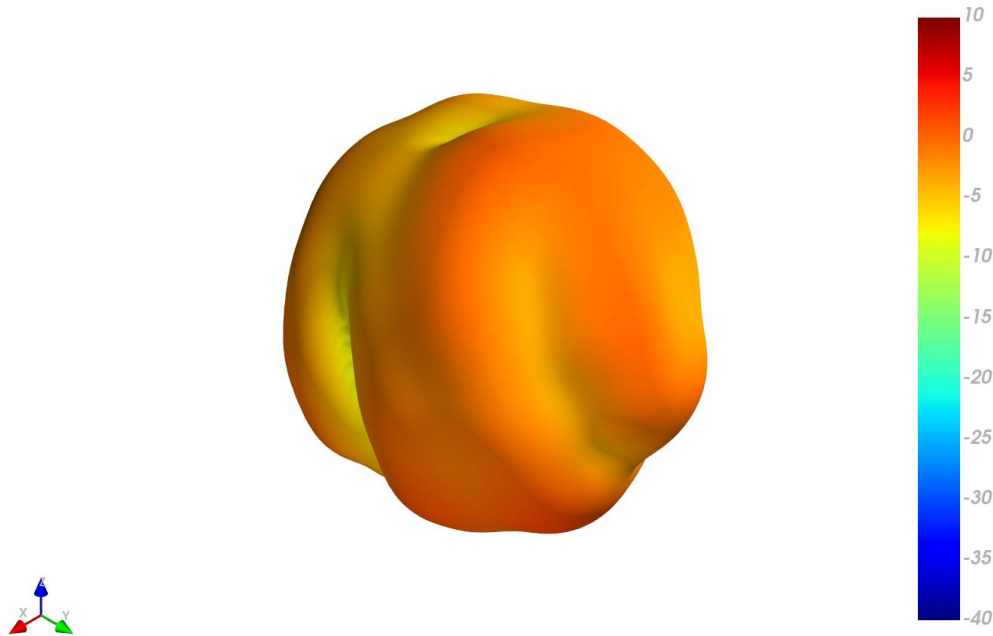

4.9 LTE 1 in Free Space - Patterns at 2595 MHz

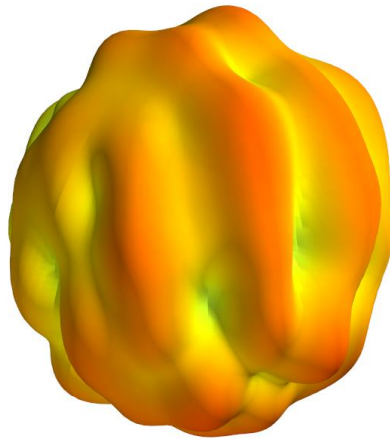

XZ Plane YZ Plane XY Plane

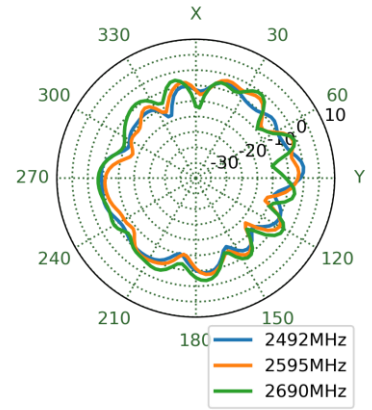
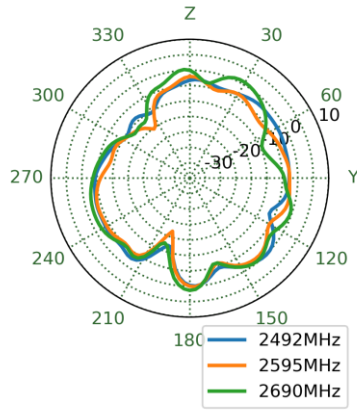
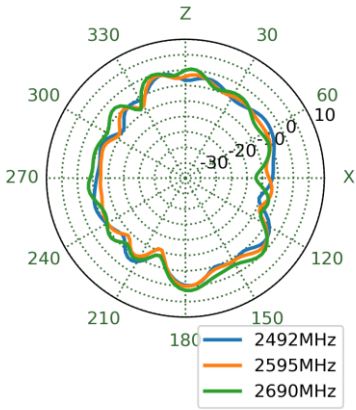

4.10 LTE 1 in Free Space - Patterns at 3550 MHz

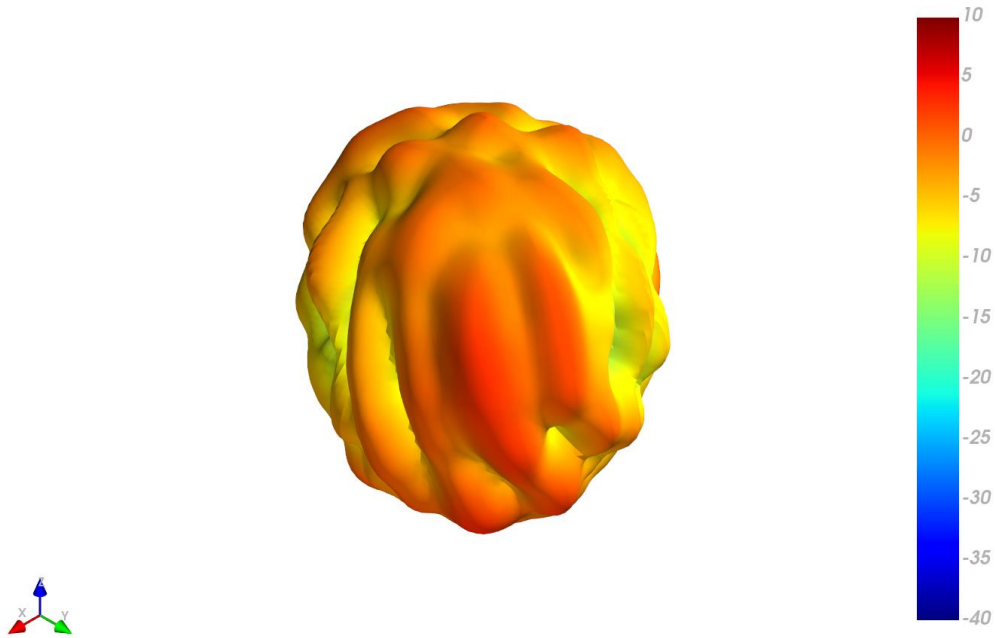

XZ Plane YZ Plane XY Plane

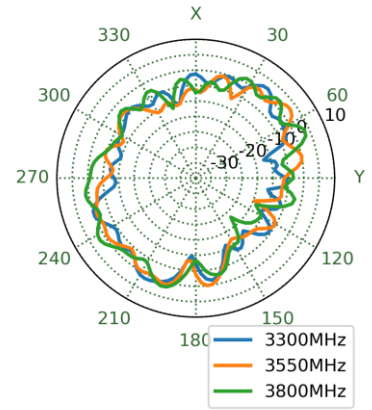
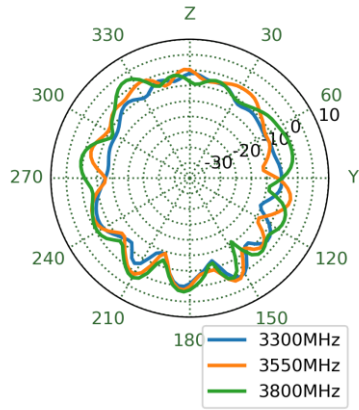
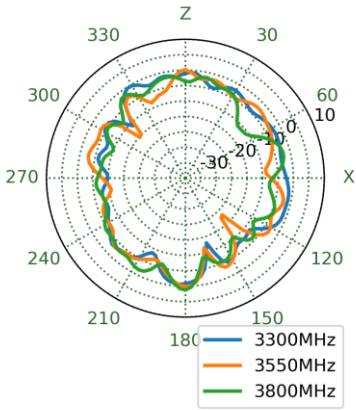

4.11 LTE 1 in Free Space - Patterns at 4800 MHz

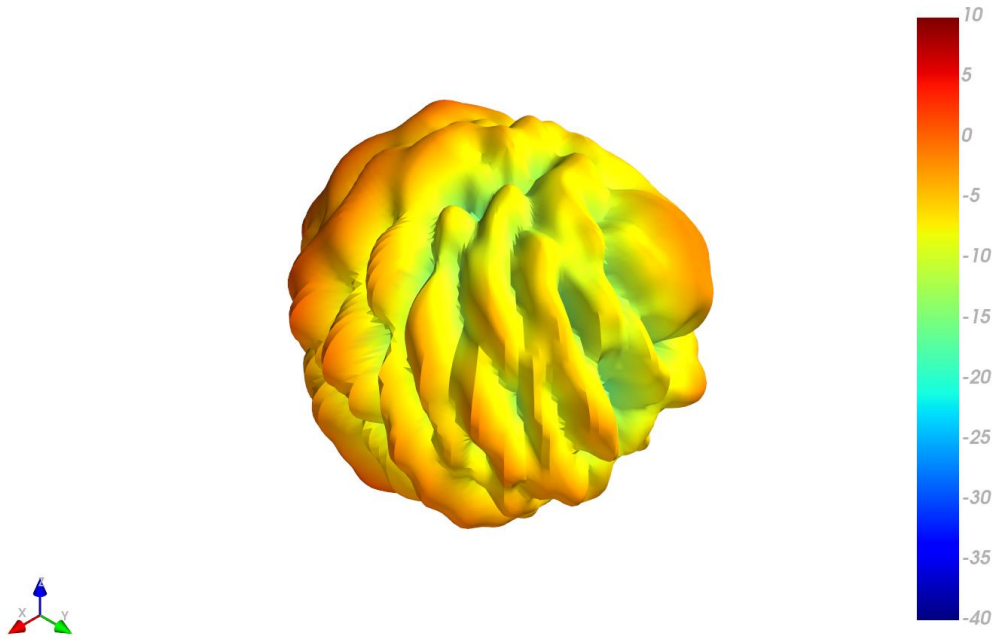

XZ Plane YZ Plane XY Plane

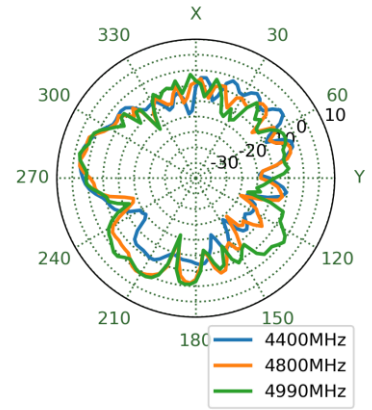
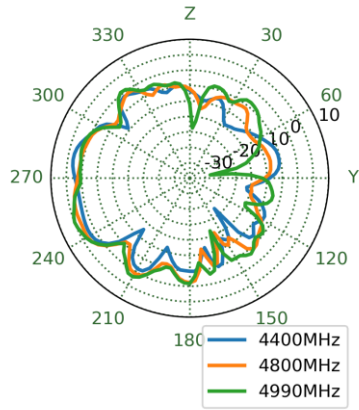
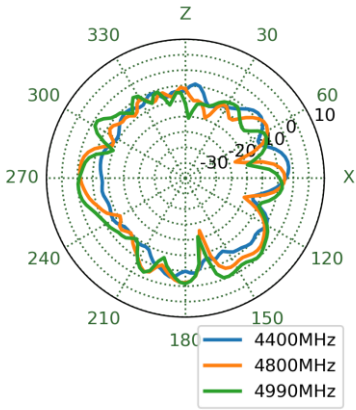

4.12 LTE 2 in Free Space - Patterns at 652 MHz

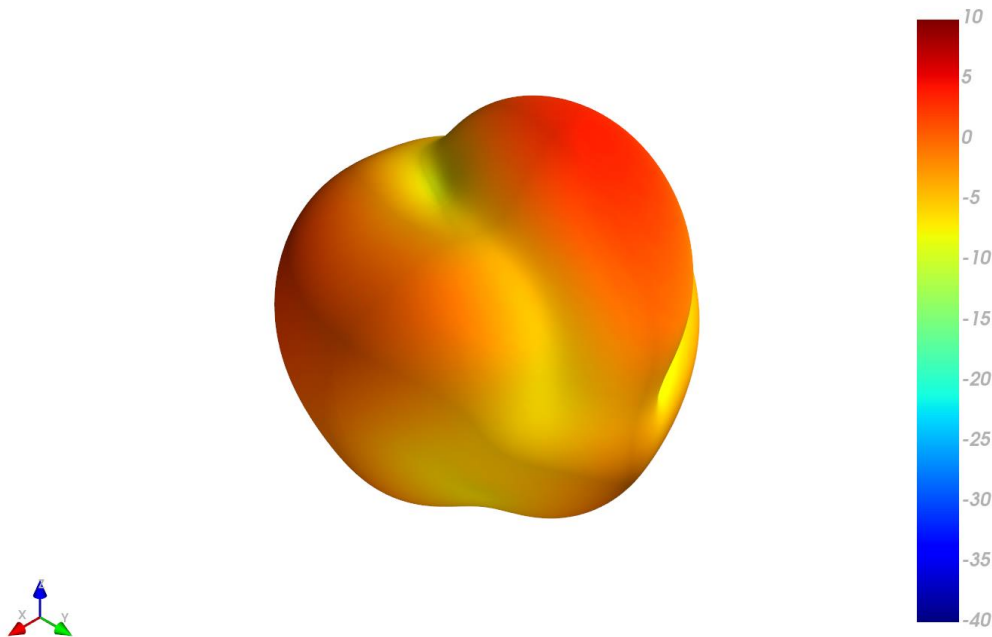

XZ Plane YZ Plane XY Plane

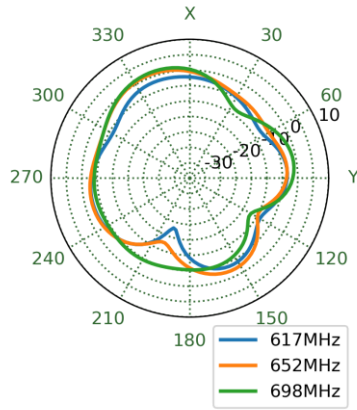
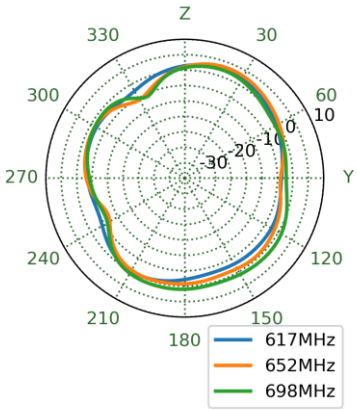
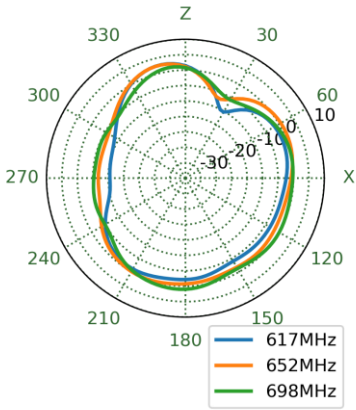

4.13 LTE 2 in Free Space - Patterns at 751 MHz

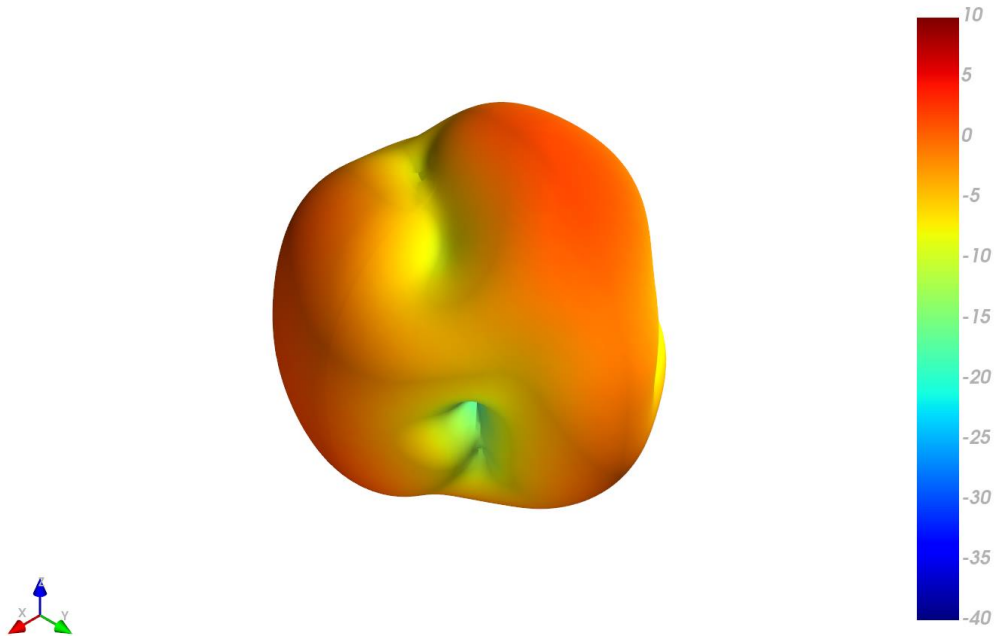

XZ Plane YZ Plane XY Plane

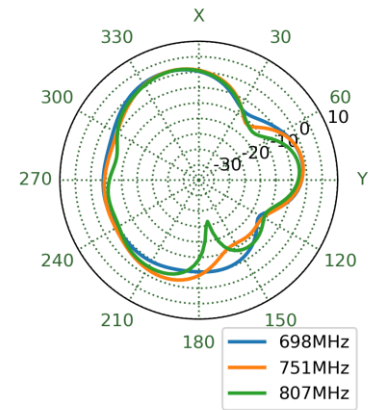
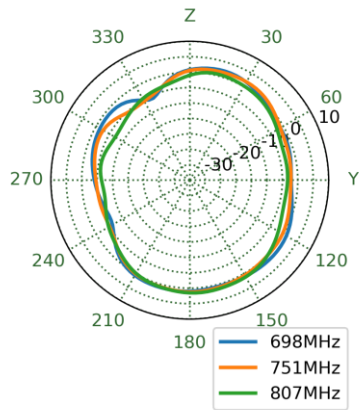
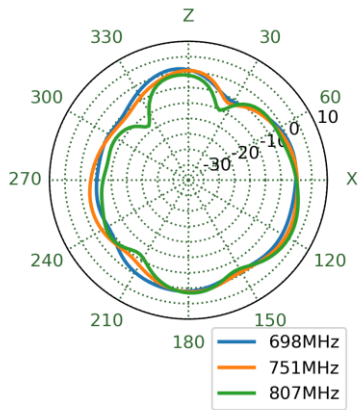

4.14 LTE 2 in Free Space - Patterns at 890 MHz

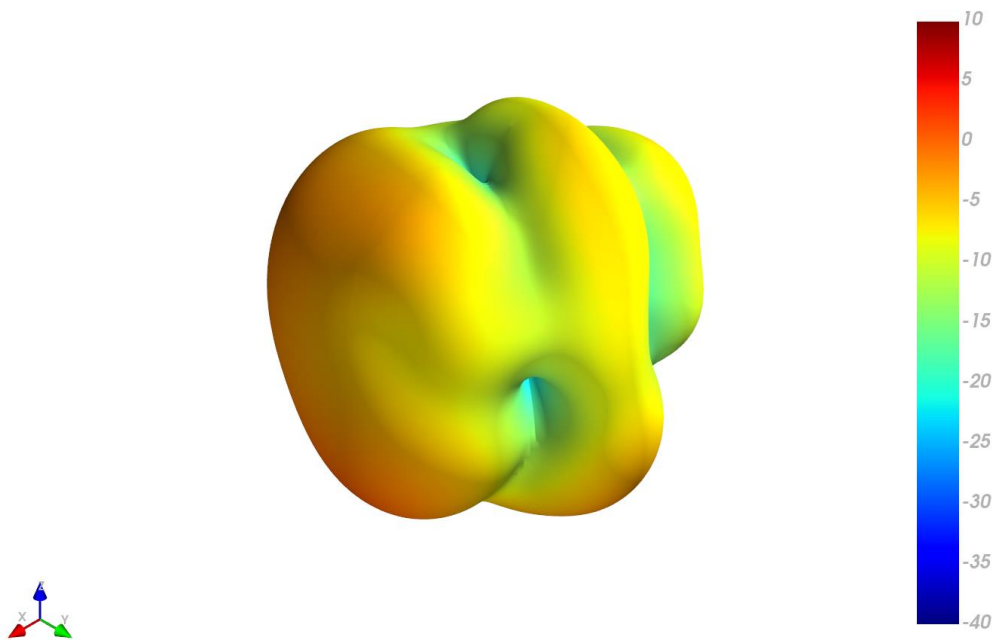

XZ Plane YZ Plane XY Plane

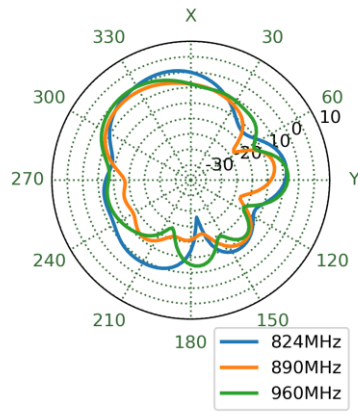
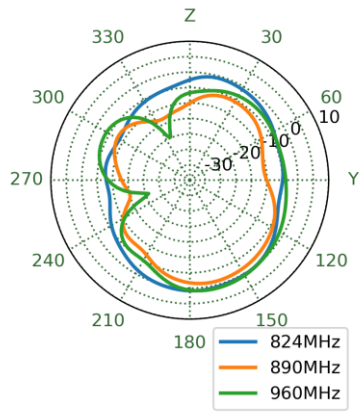
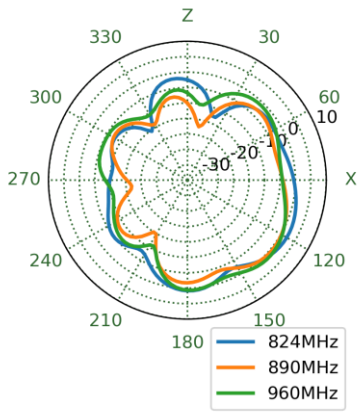

4.15 LTE 2 in Free Space - Patterns at 1470 MHz

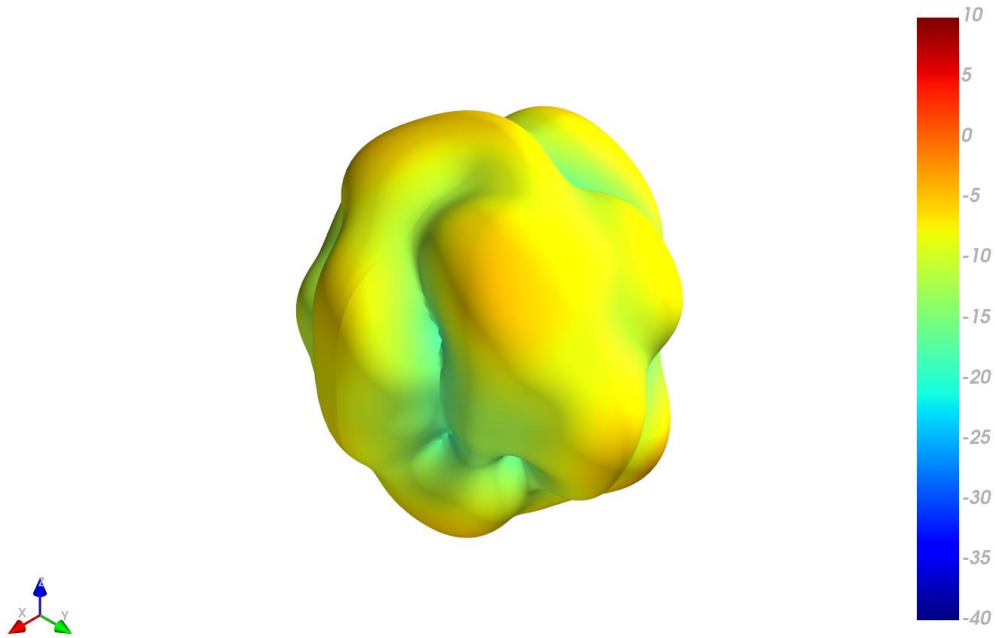

XZ Plane YZ Plane XY Plane

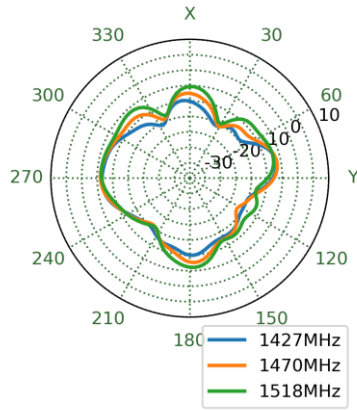
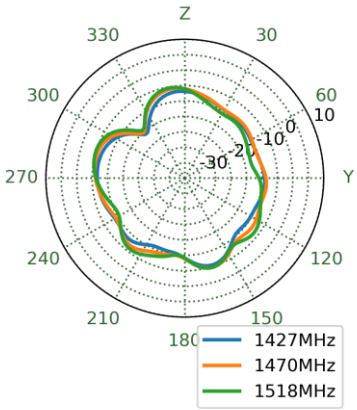
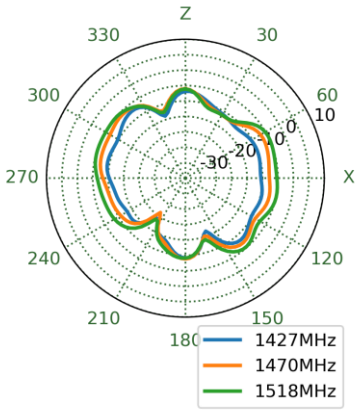

4.16 LTE 2 in Free Space - Patterns at 1805 MHz

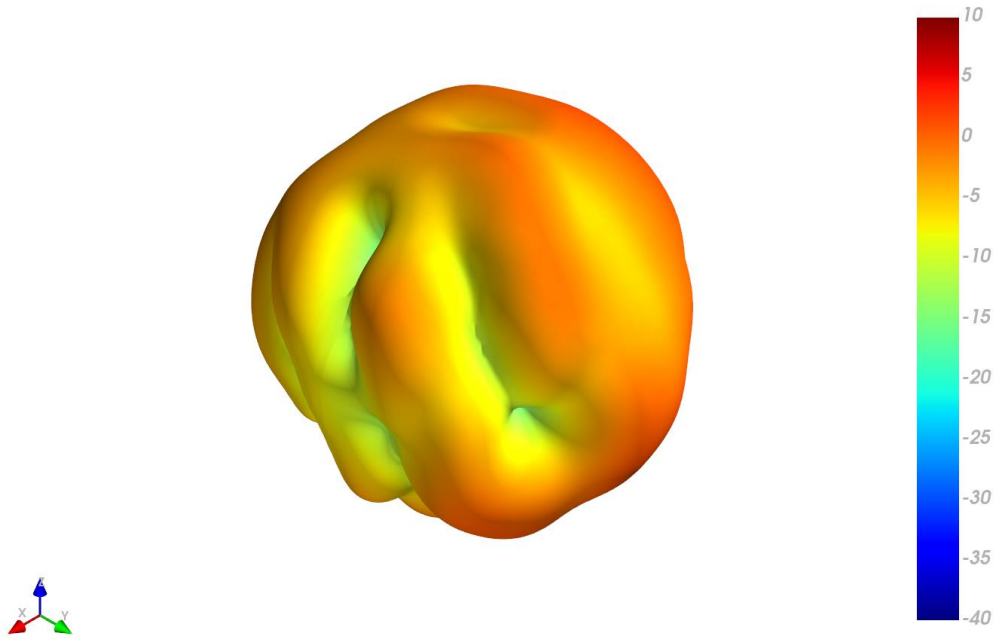

XZ Plane YZ Plane XY Plane

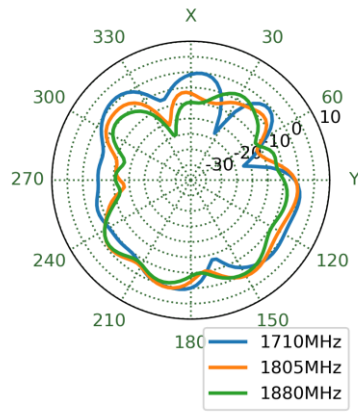
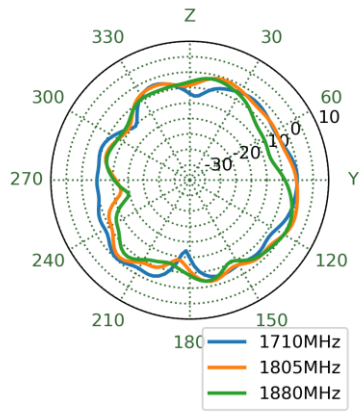
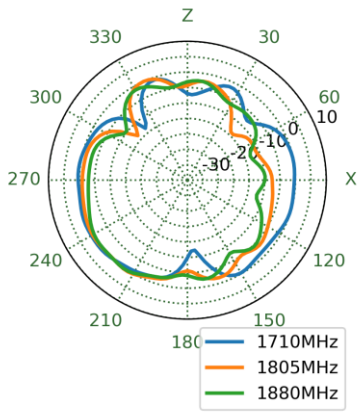

4.17 LTE 2 in Free Space - Patterns at 1920 MHz

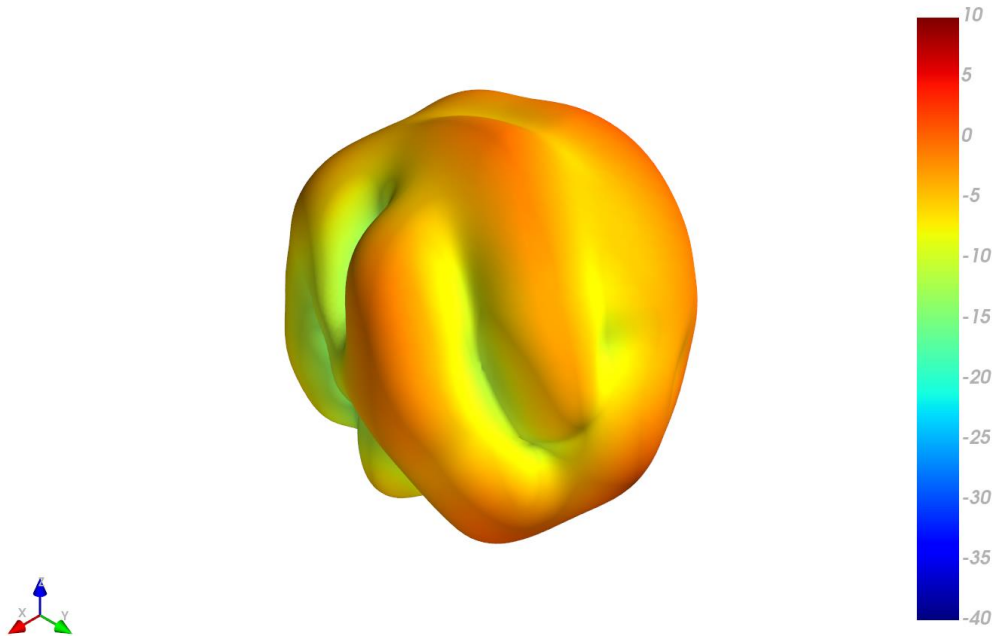

XZ Plane YZ Plane XY Plane

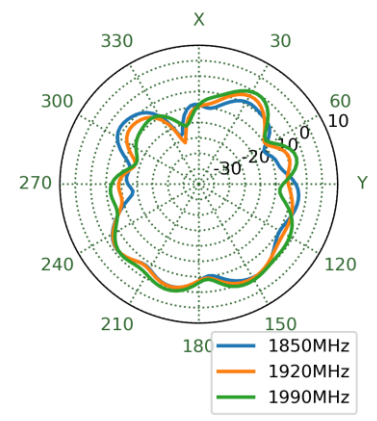
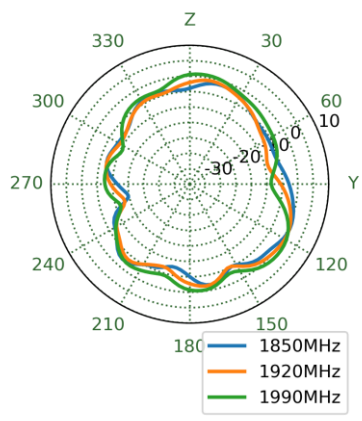
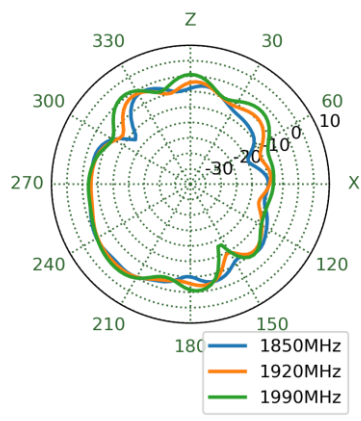

4.18 LTE 2 in Free Space - Patterns at 1990 MHz

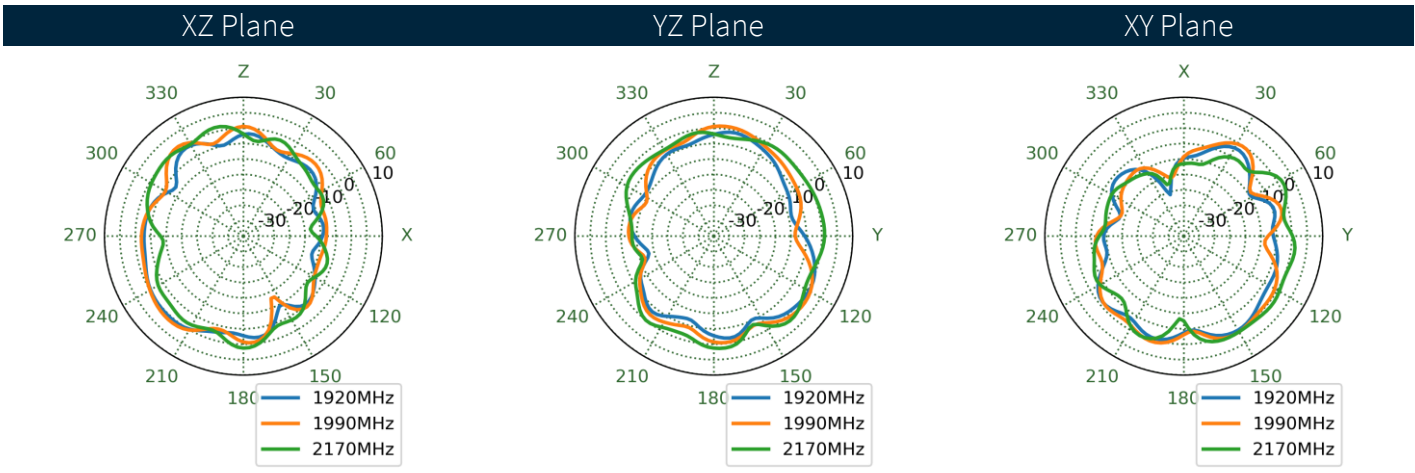
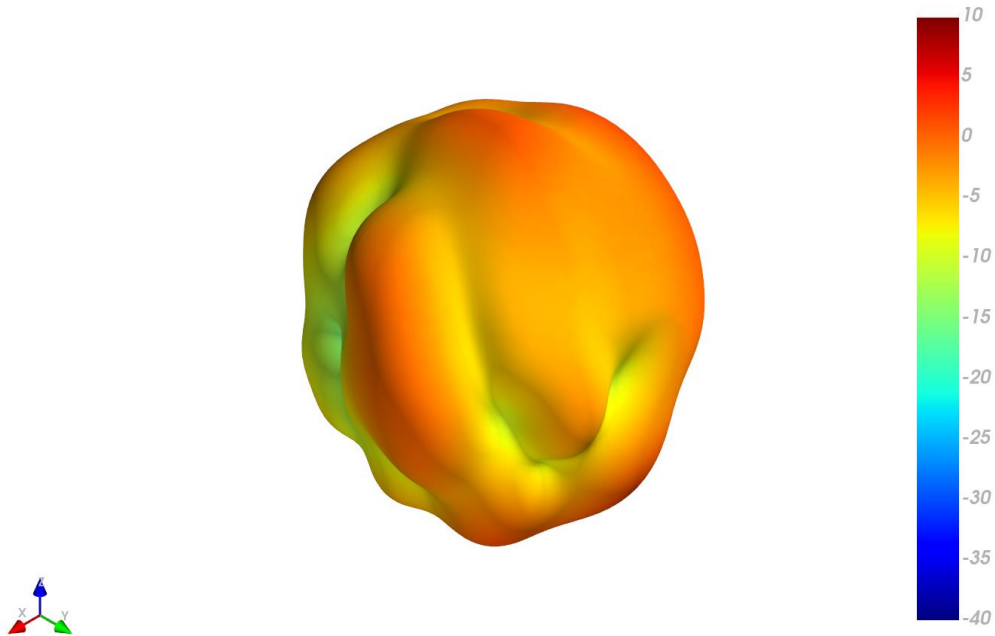

4.19 LTE 2 in Free Space - Patterns at 2595 MHz

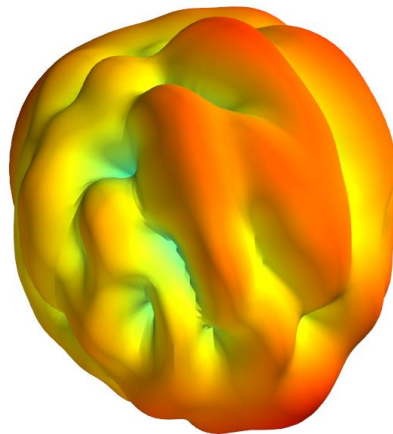

XZ Plane YZ Plane XY Plane

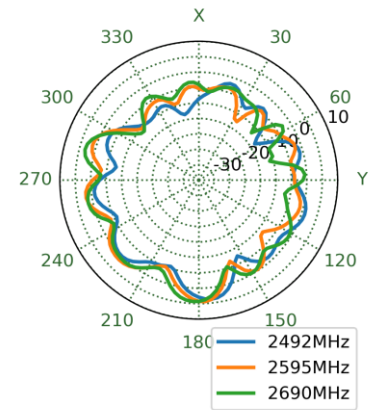
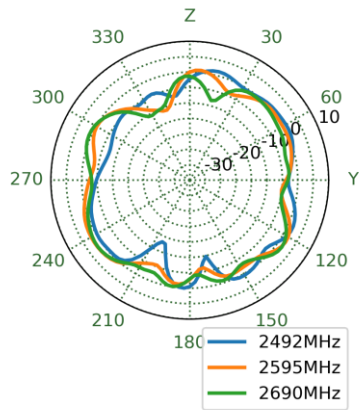
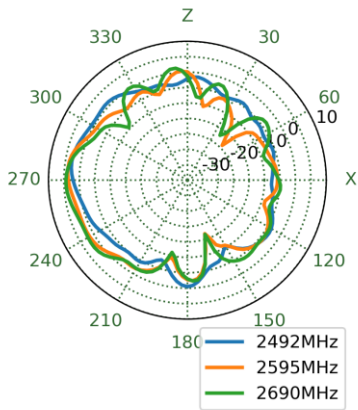

4.20 LTE 2 in Free Space - Patterns at 3550 MHz

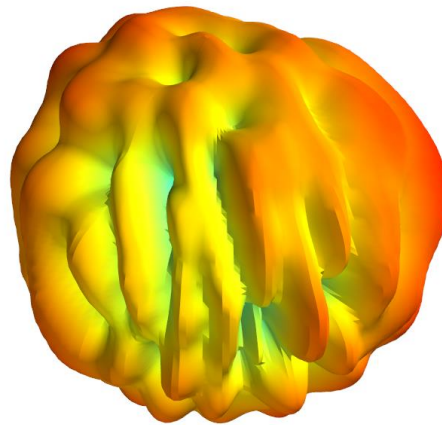

XZ Plane YZ Plane XY Plane

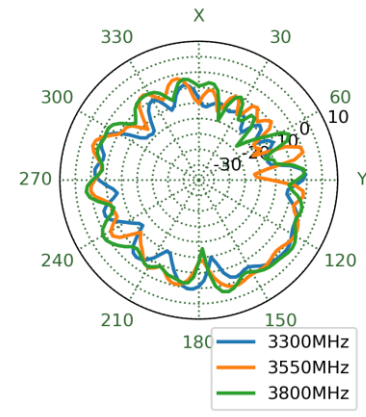
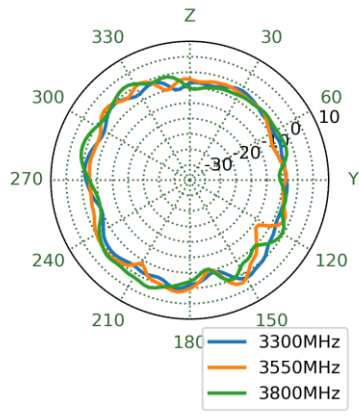
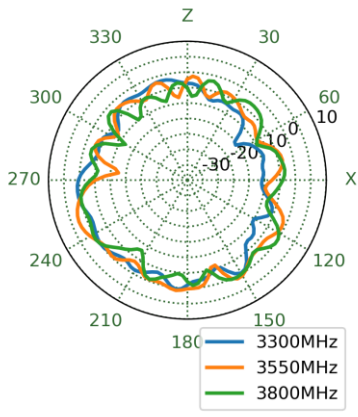

4.21 LTE 2 in Free Space - Patterns at 4800 MHz

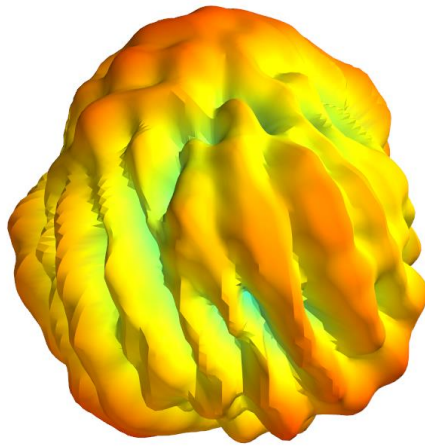

XZ Plane YZ Plane XY Plane

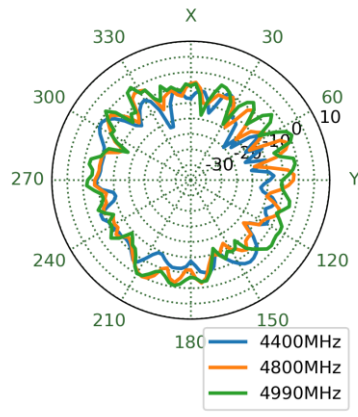
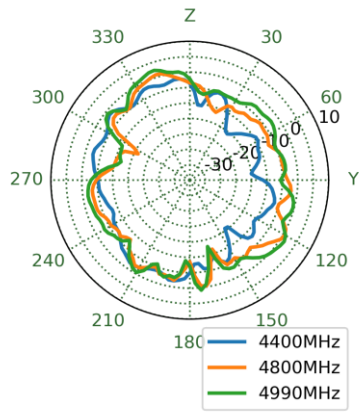
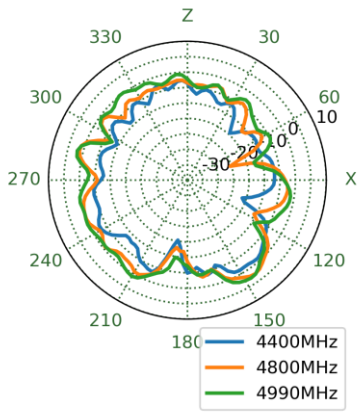

4.22 LTE 1 on 30x30cm Ground Plane - Patterns at 652 MHz

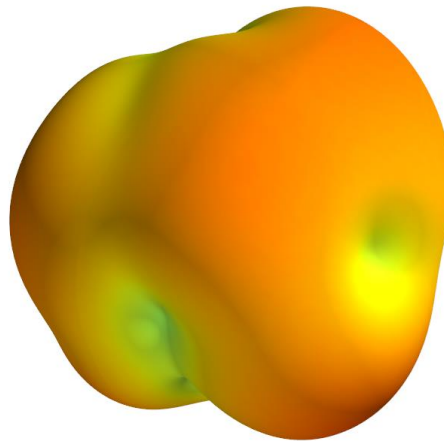

XZ Plane YZ Plane XY Plane

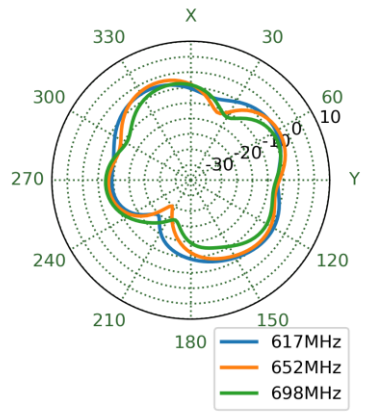
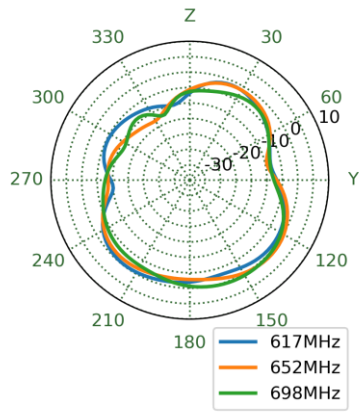
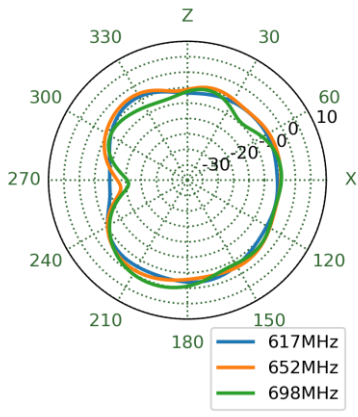

4.23 LTE 1 on 30x30cm Ground Plane - Patterns at 751 MHz

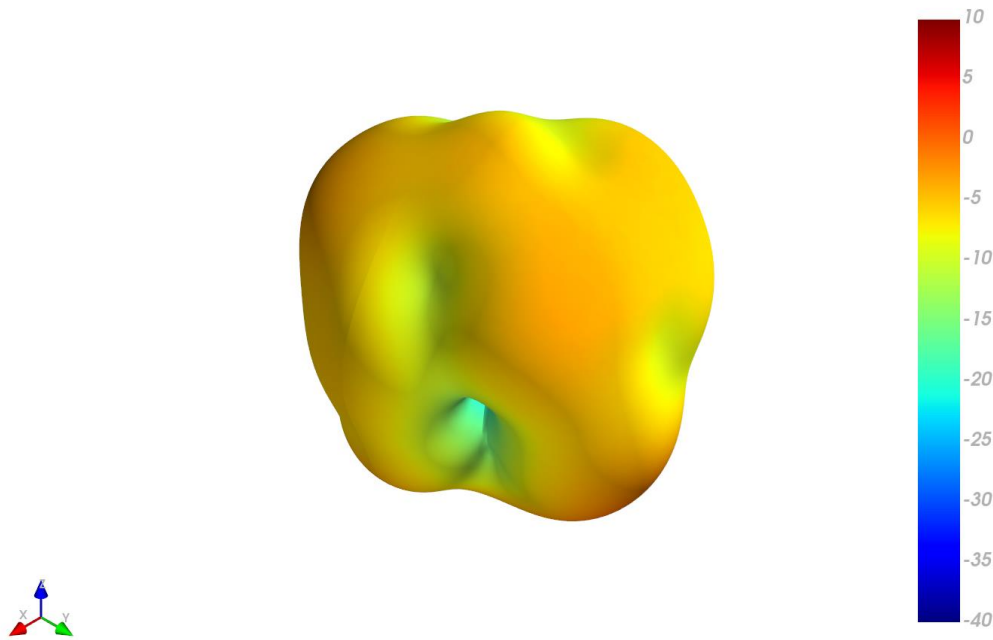

XZ Plane YZ Plane XY Plane

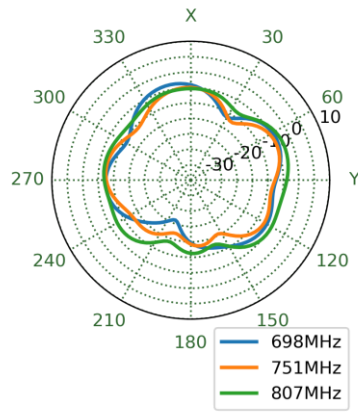
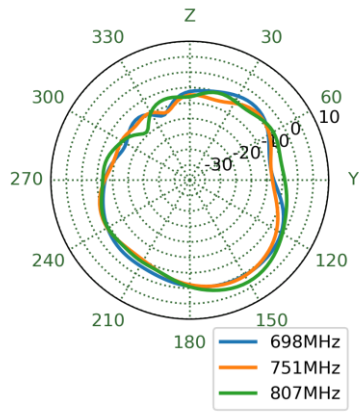
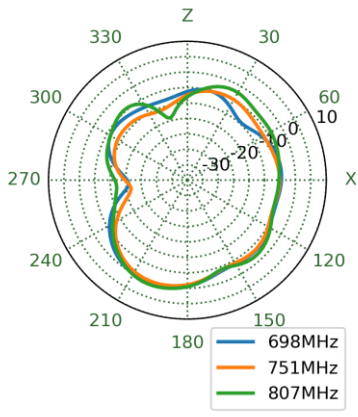

4.24 LTE 1 on 30x30cm Ground Plane - Patterns at 890 MHz

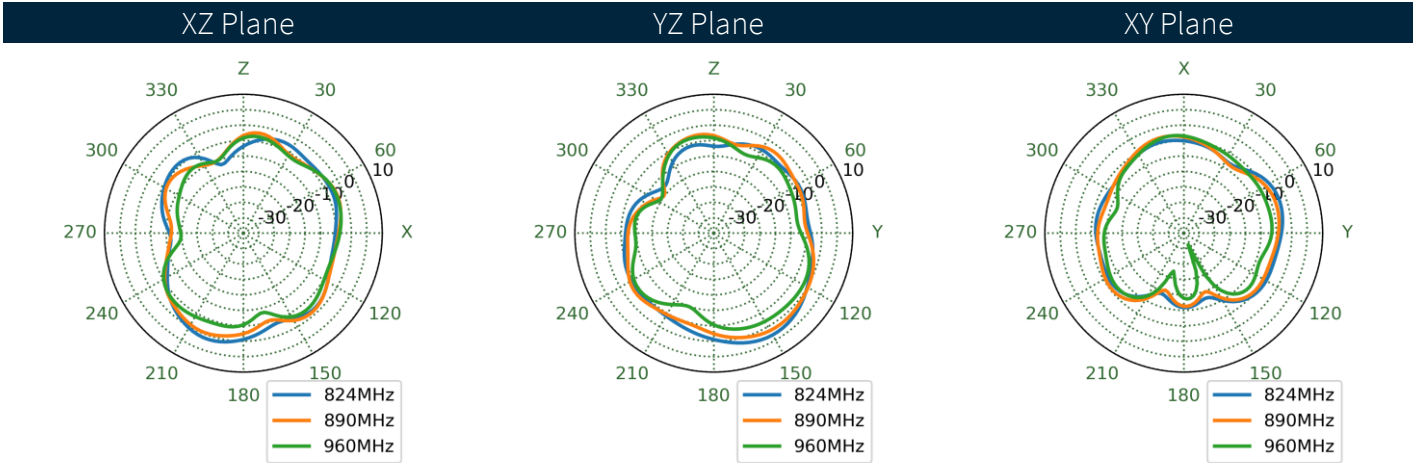
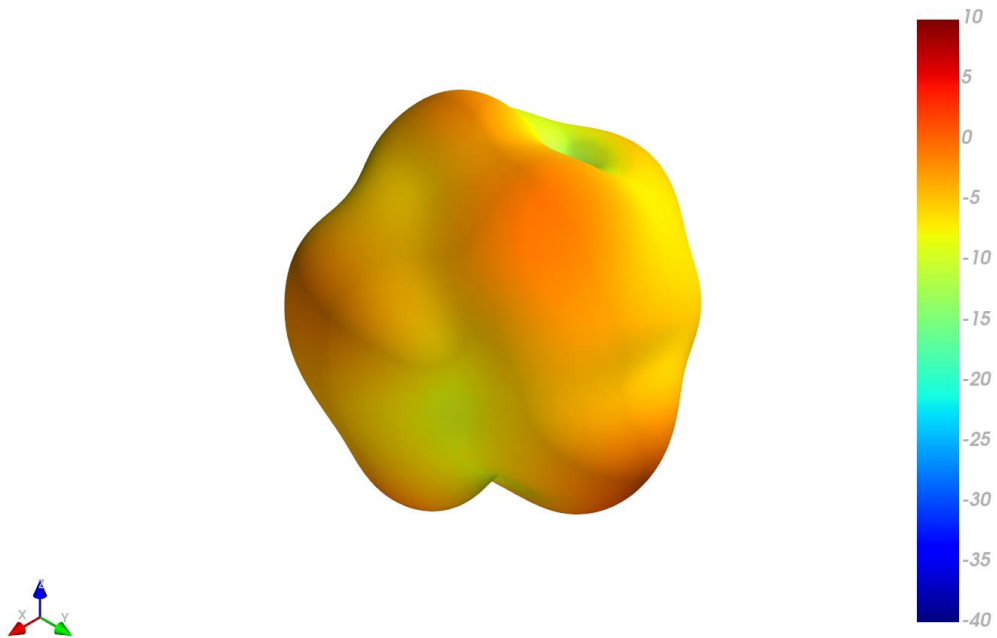

4.25 LTE 1 on 30x30cm Ground Plane - Patterns at 1470 MHz

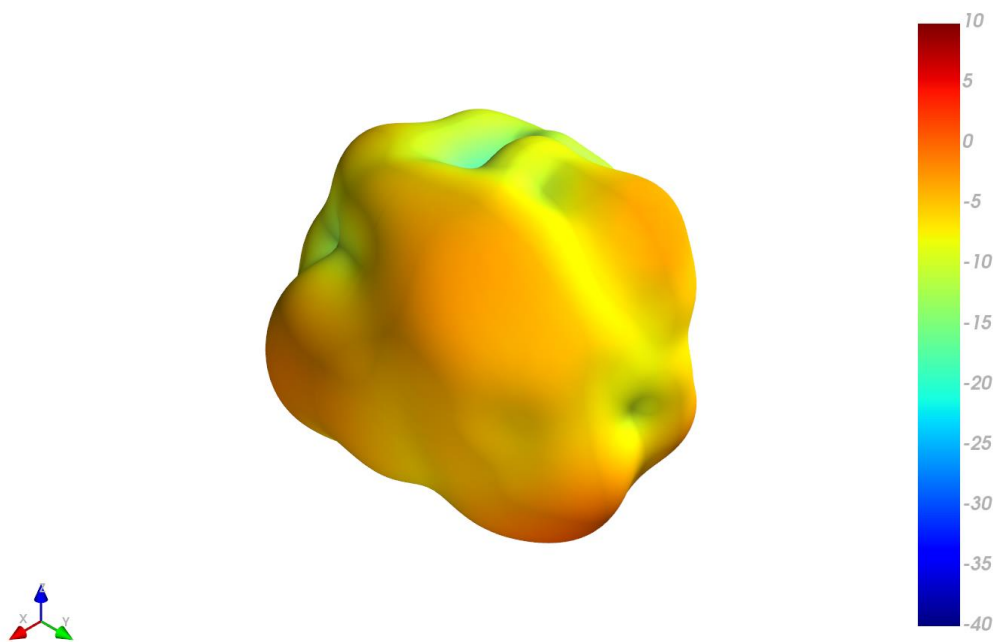

XZ Plane YZ Plane XY Plane

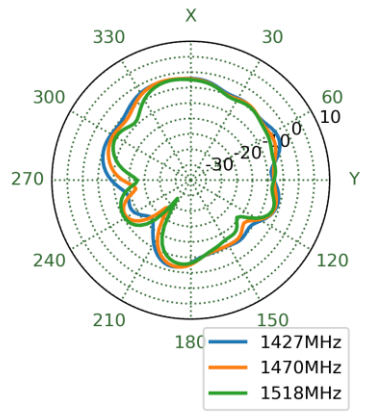
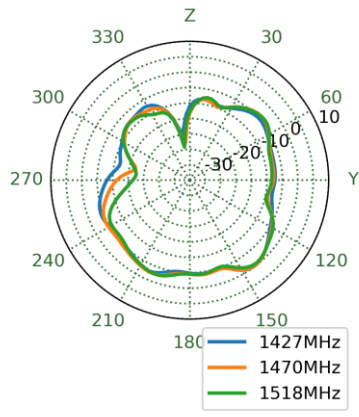
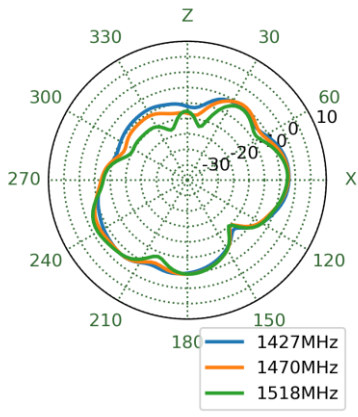

4.26 LTE 1 on 30x30cm Ground Plane - Patterns at 1805 MHz

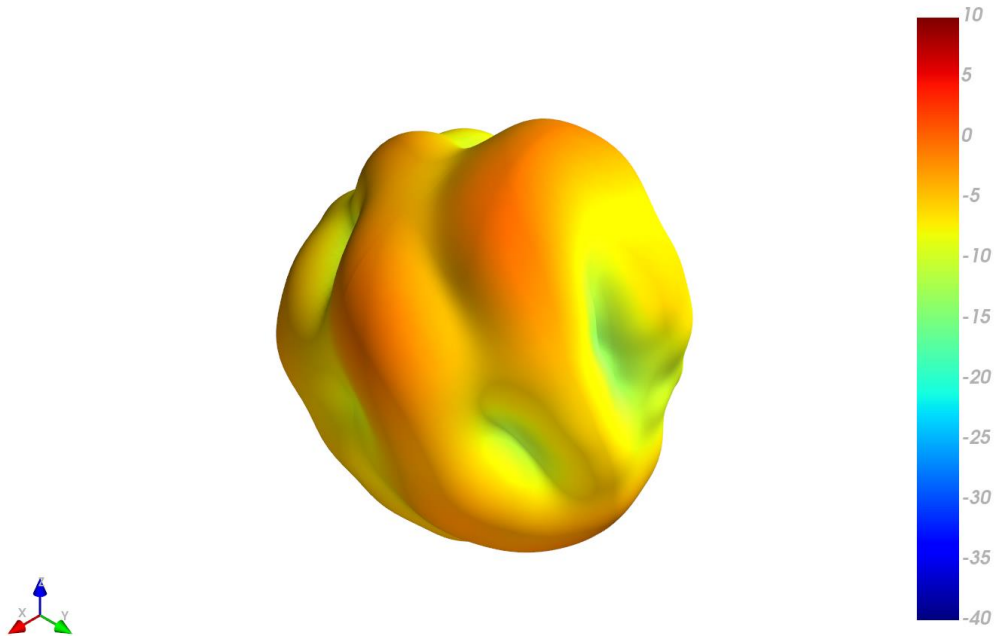

XZ Plane YZ Plane XY Plane

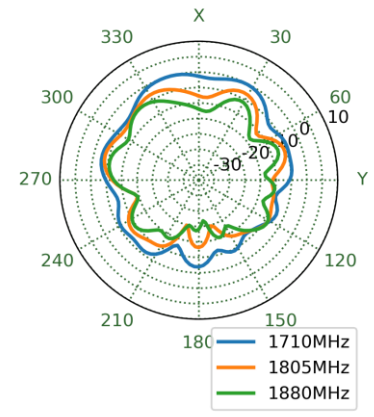
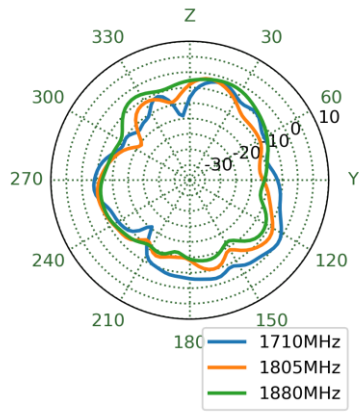
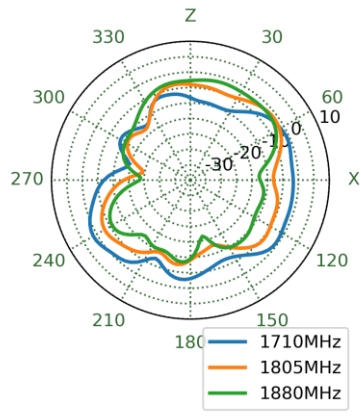

4.27 LTE 1 on 30x30cm Ground Plane - Patterns at 1920 MHz

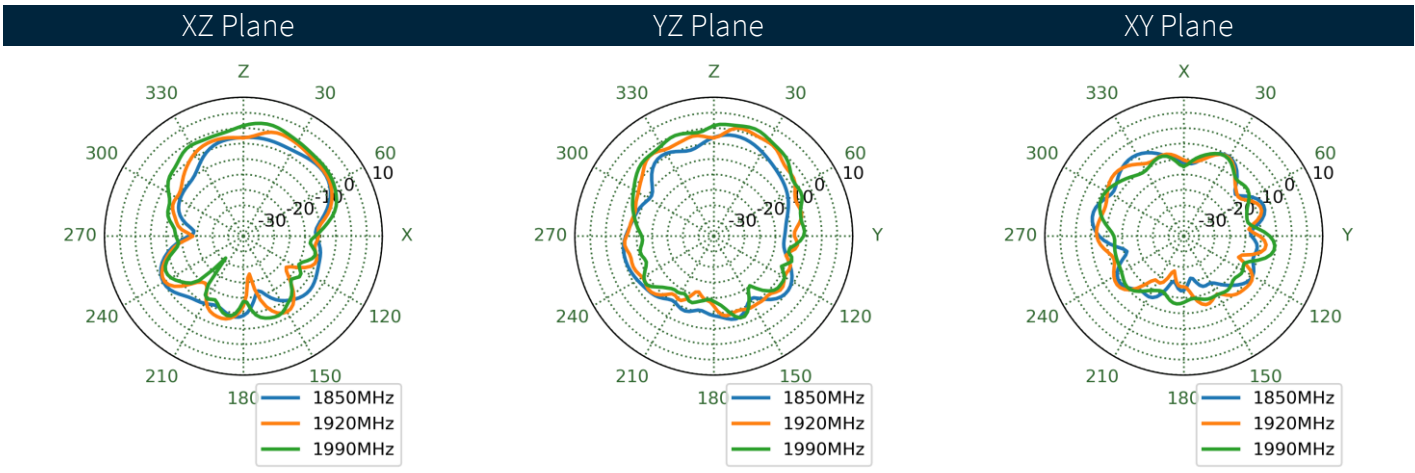
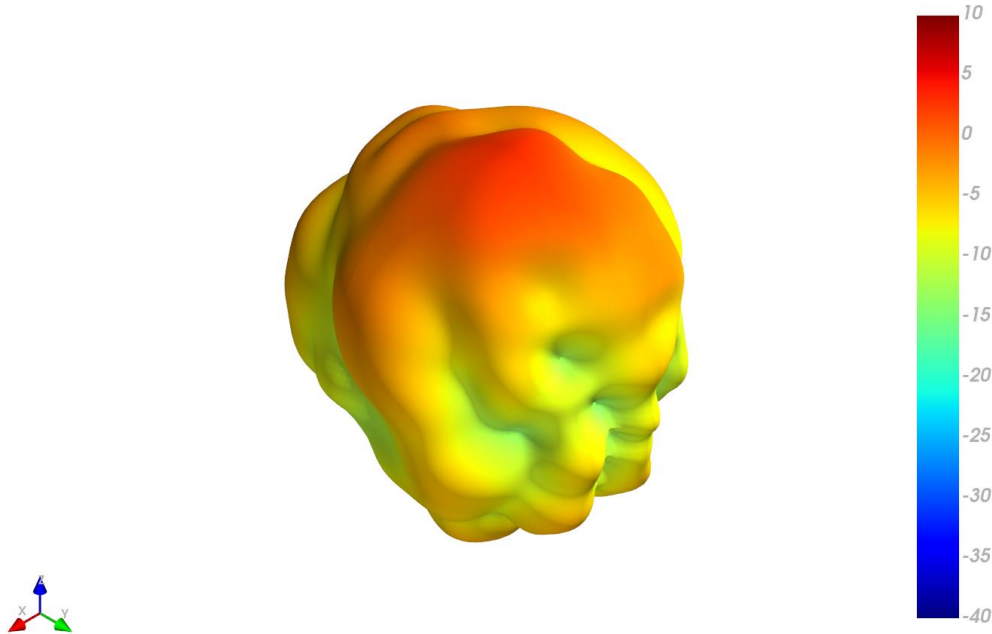

4.28 LTE 1 on 30x30cm Ground Plane - Patterns at 1990 MHz

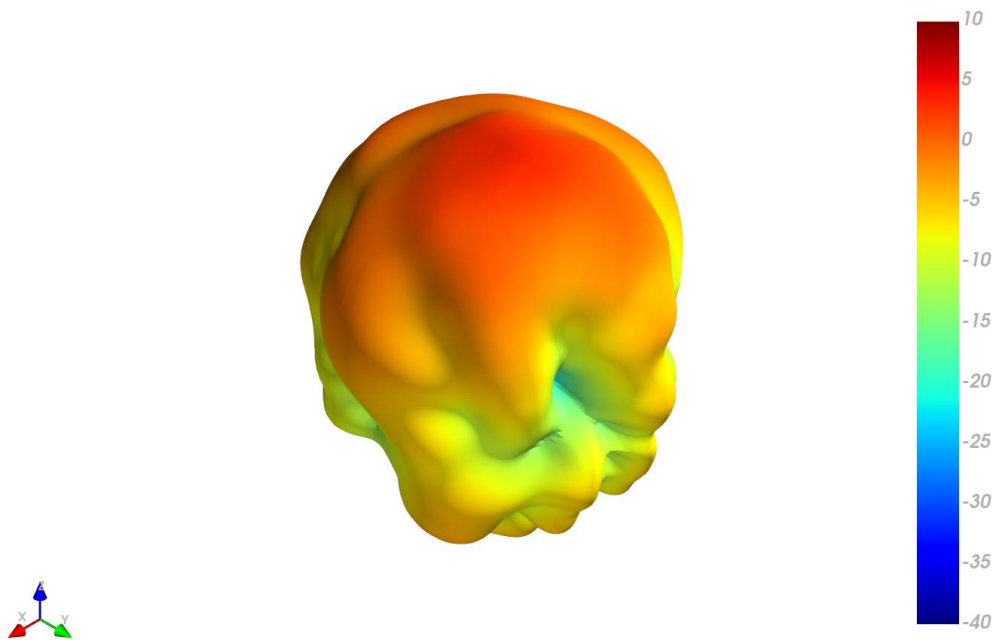

XZ Plane YZ Plane XY Plane

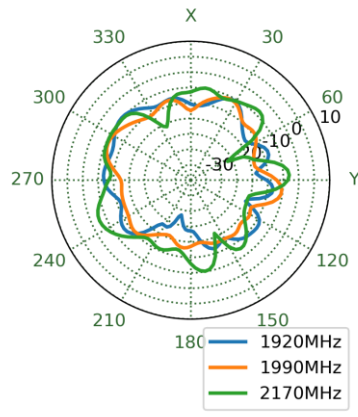
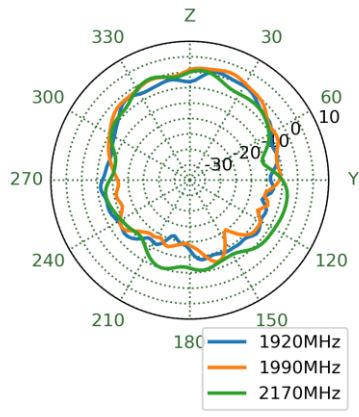
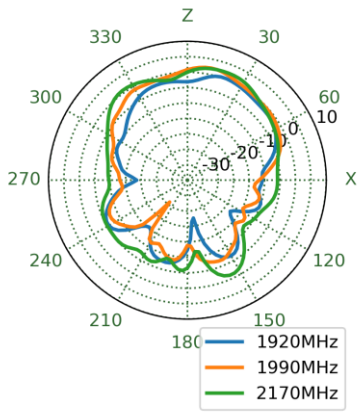

4.29 LTE 1 on 30x30cm Ground Plane - Patterns at 2595 MHz

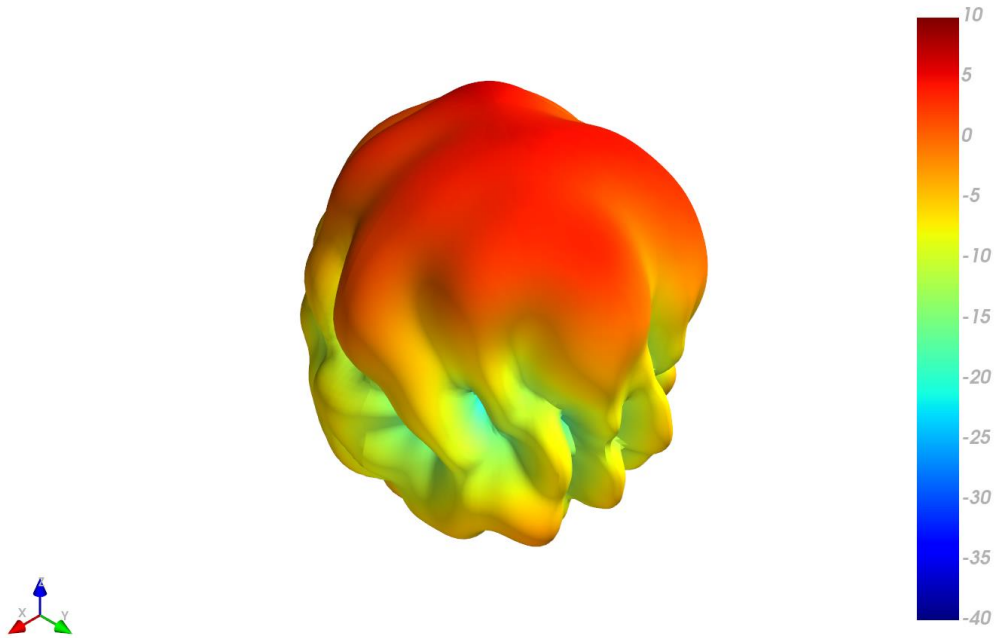

XZ Plane YZ Plane XY Plane

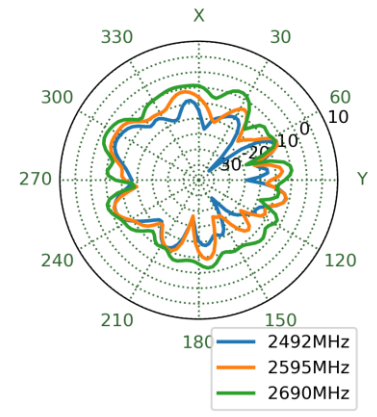
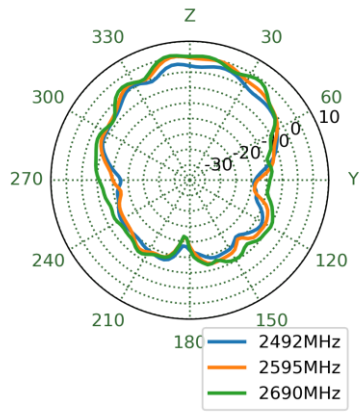
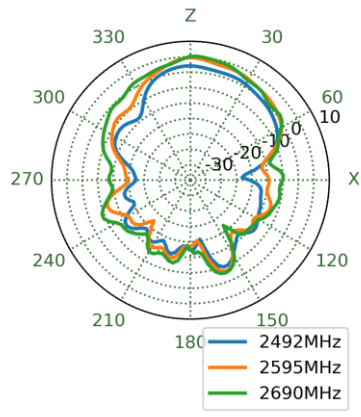

4.30 LTE 1 on 30x30cm Ground Plane - Patterns at 3550 MHz

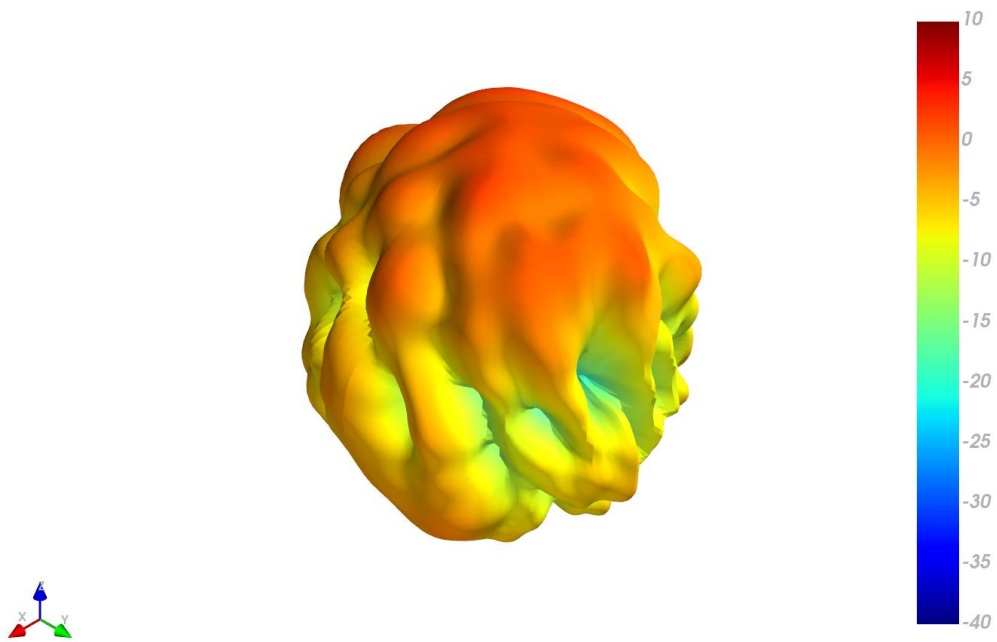

XZ Plane YZ Plane XY Plane

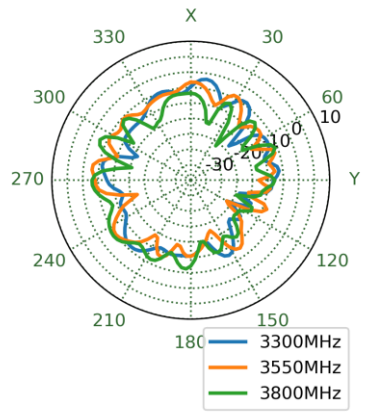
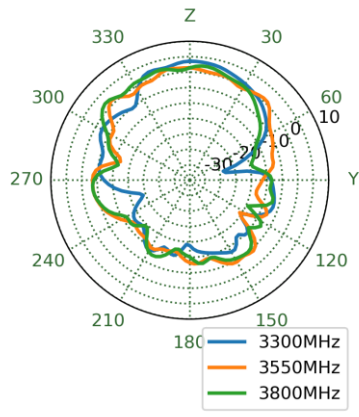
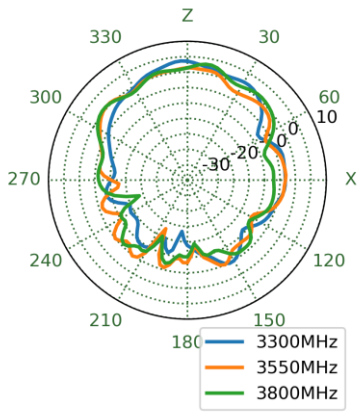

4.31 LTE 1 on 30x30cm Ground Plane - Patterns at 4800 MHz

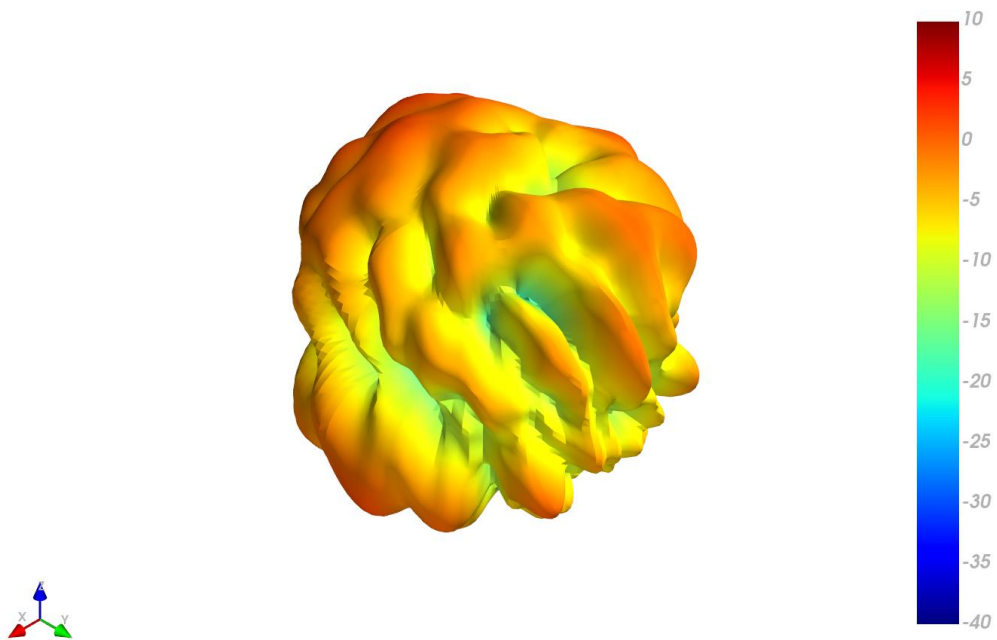

XZ Plane YZ Plane XY Plane

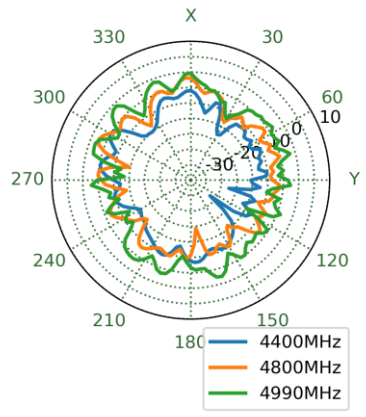
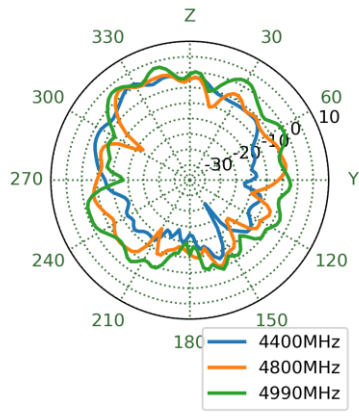
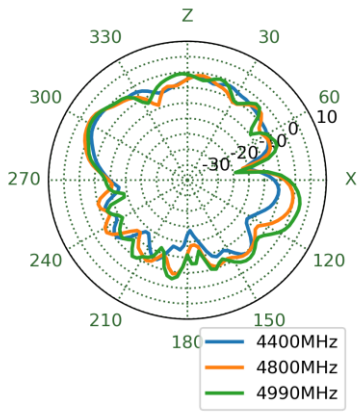

4.32 LTE 2 on 30x30cm Ground Plane - Patterns at 652 MHz

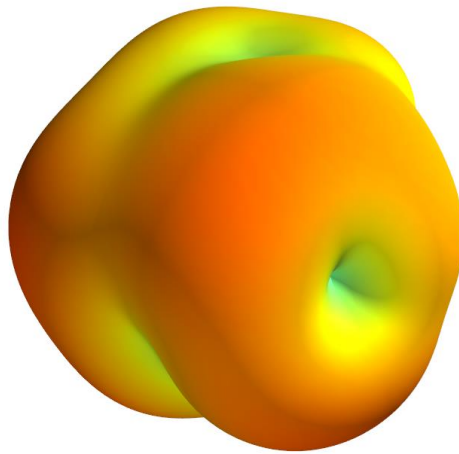

XZ Plane YZ Plane XY Plane

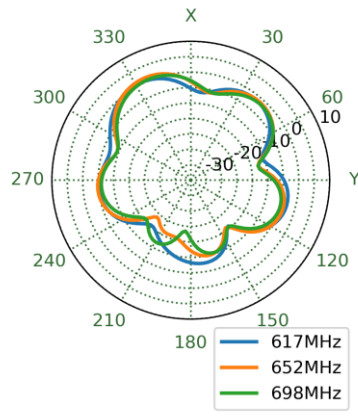
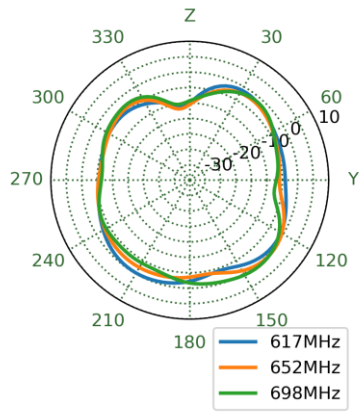
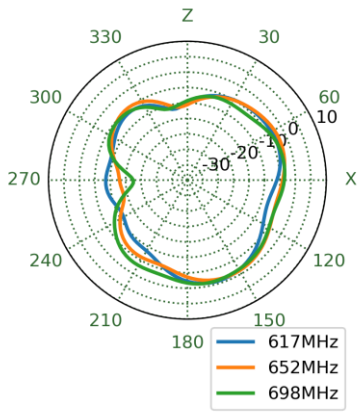

4.33 LTE 2 on 30x30cm Ground Plane - Patterns at 751 MHz

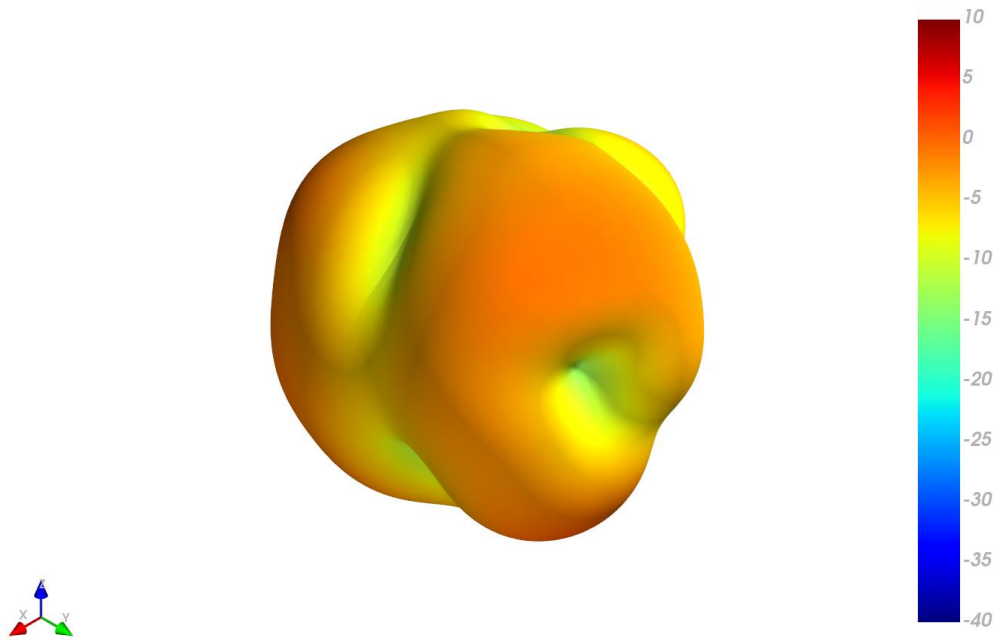

XZ Plane YZ Plane XY Plane

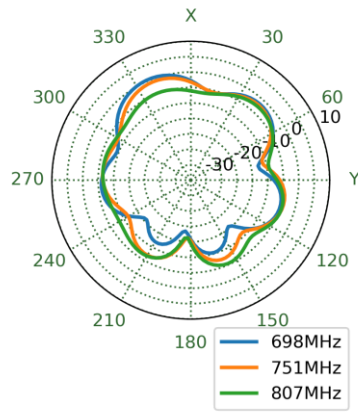
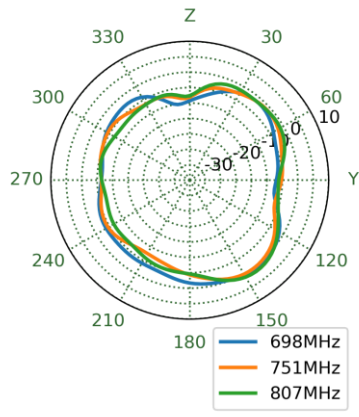
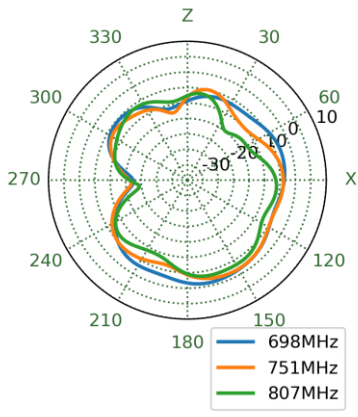

4.34 LTE 2 on 30x30cm Ground Plane - Patterns at 890 MHz

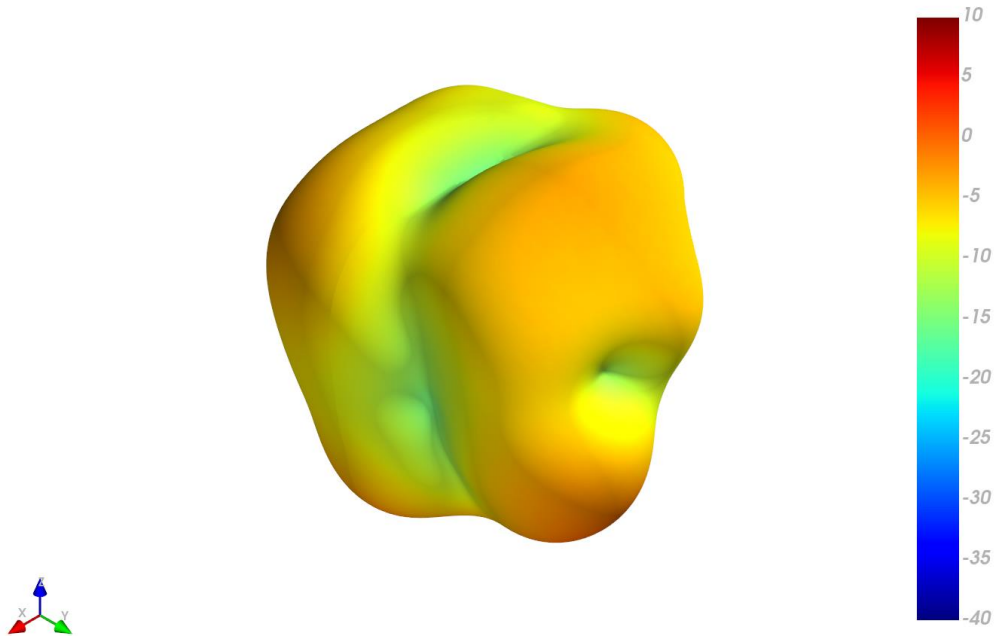

XZ Plane YZ Plane XY Plane

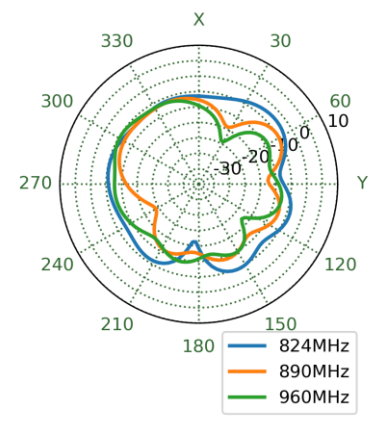
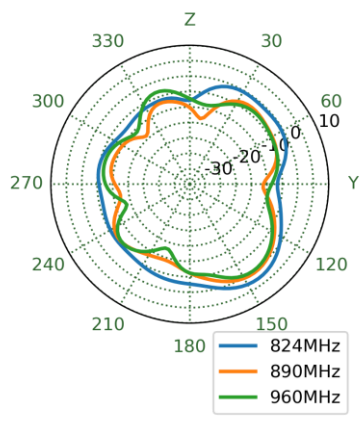
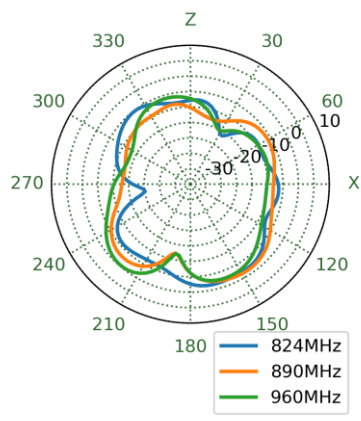

4.35 LTE 2 on 30x30cm Ground Plane - Patterns at 1470 MHz

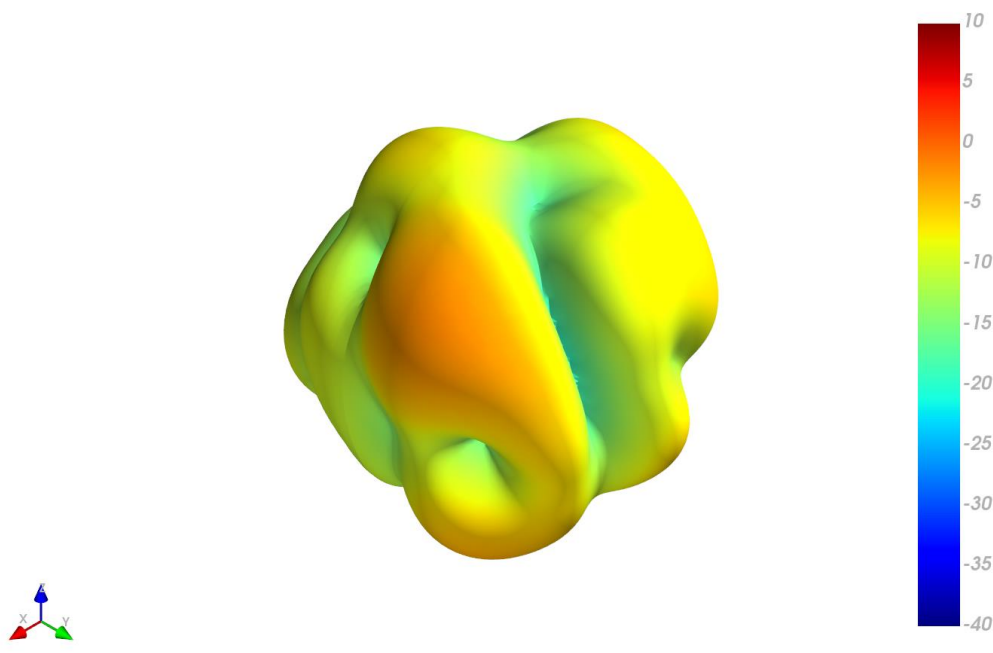

XZ Plane YZ Plane XY Plane

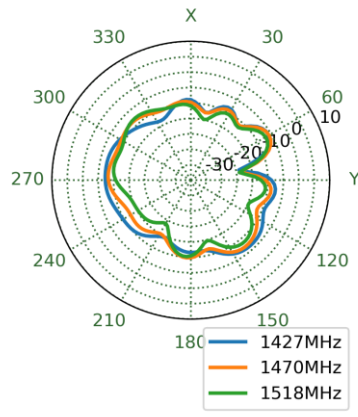
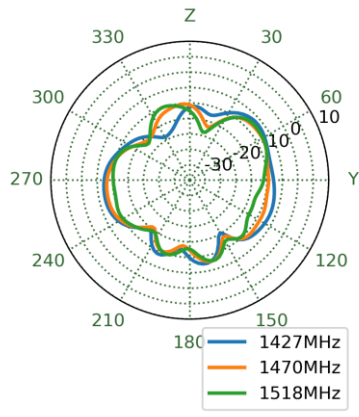
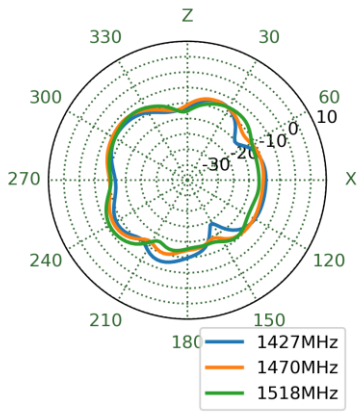

4.36 LTE 2 on 30x30cm Ground Plane - Patterns at 1805 MHz

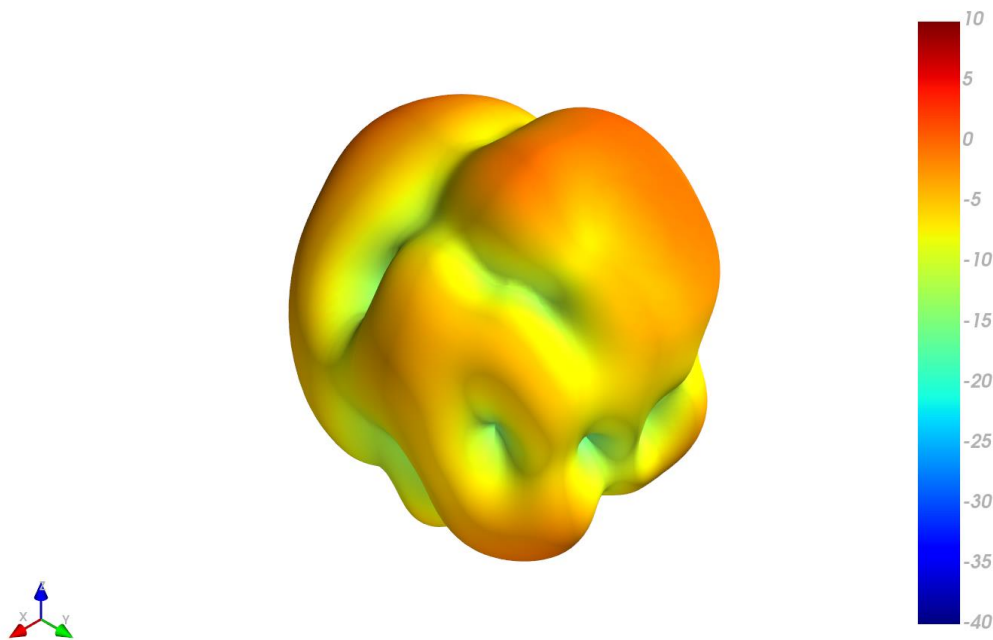

XZ Plane YZ Plane XY Plane

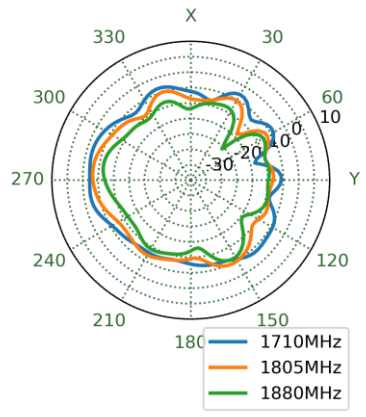
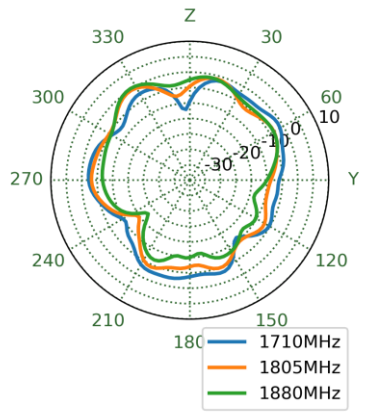
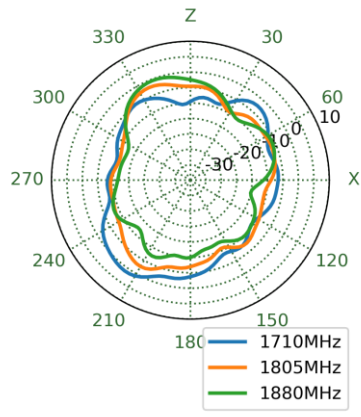

4.37 LTE 2 on 30x30cm Ground Plane - Patterns at 1920 MHz

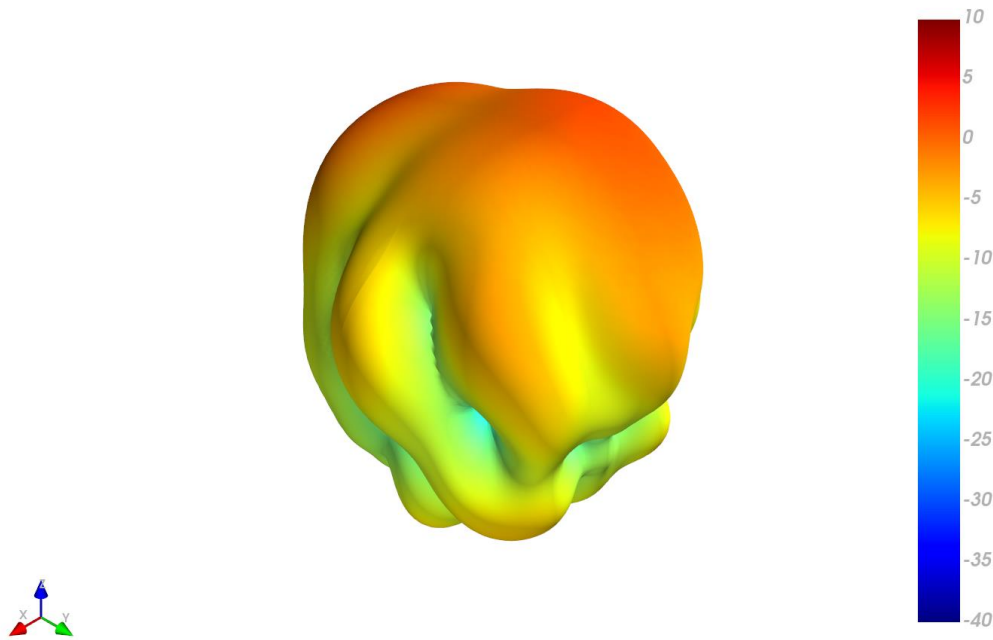

XZ Plane YZ Plane XY Plane

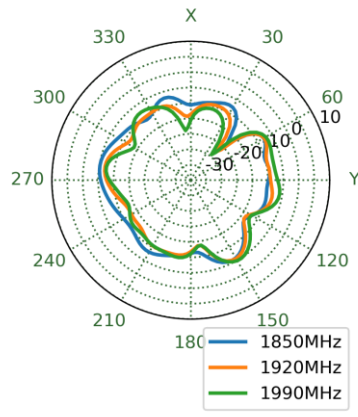
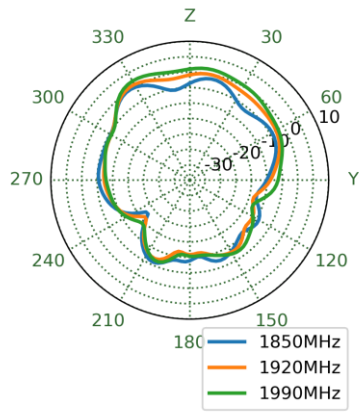
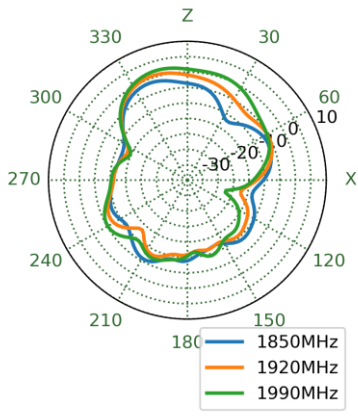

4.38 LTE 2 on 30x30cm Ground Plane - Patterns at 1990 MHz

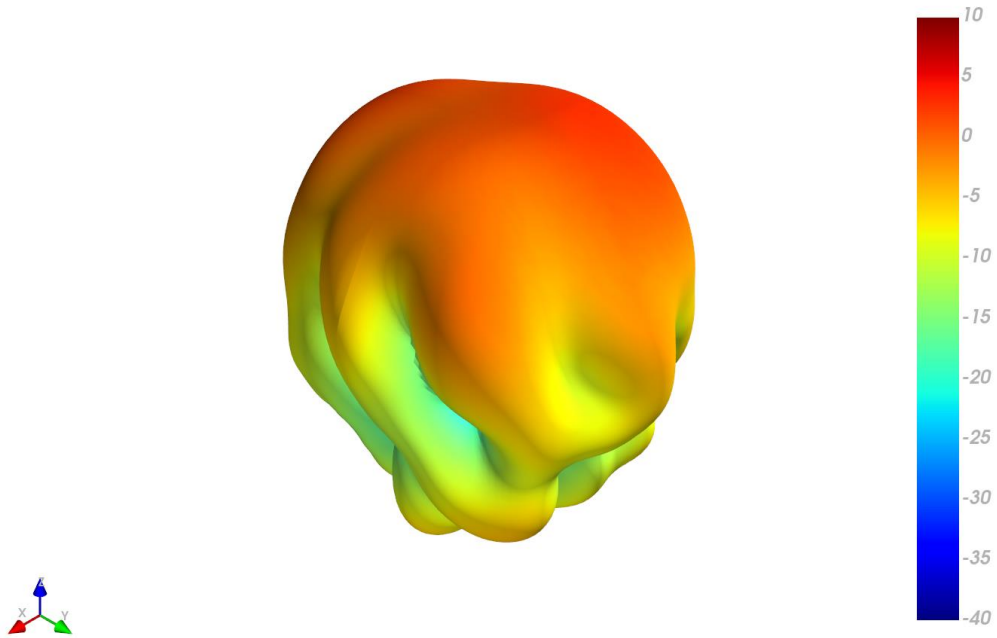

XZ Plane YZ Plane XY Plane

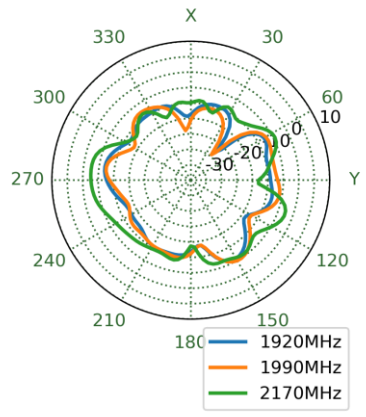
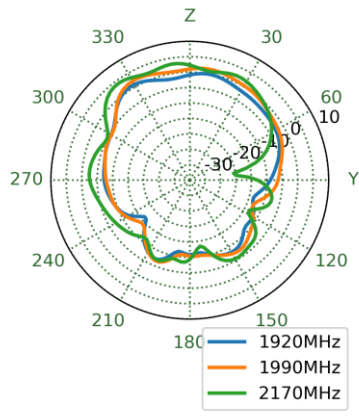
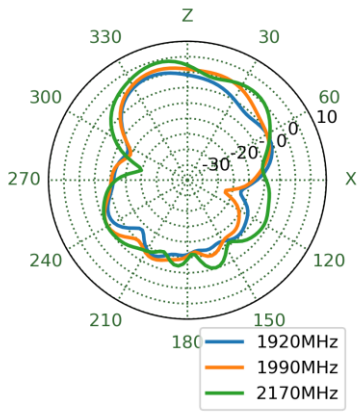

4.39 LTE 2 on 30x30cm Ground Plane - Patterns at 2595 MHz

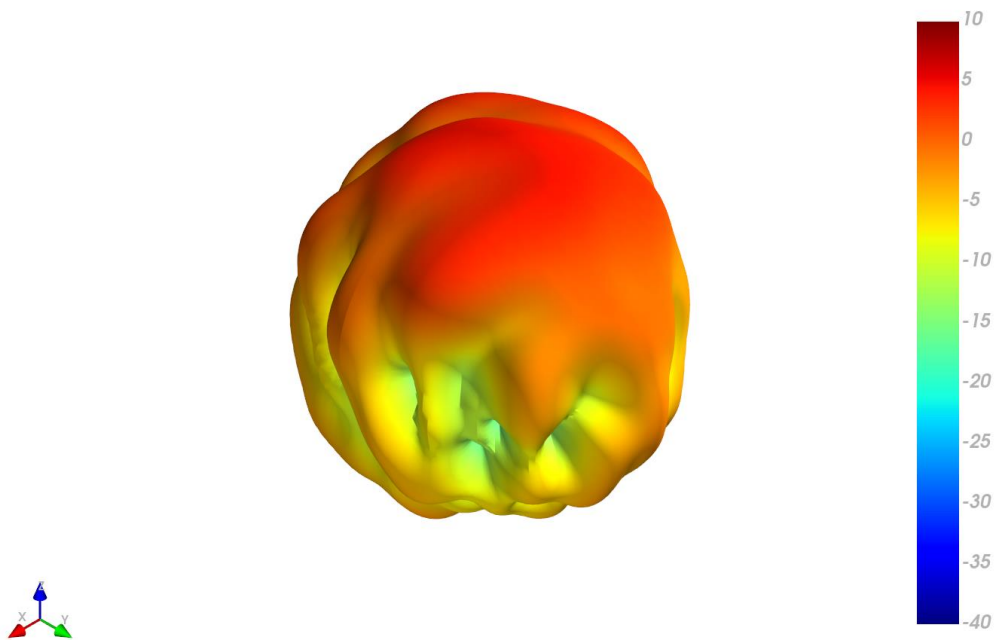

XZ Plane YZ Plane XY Plane

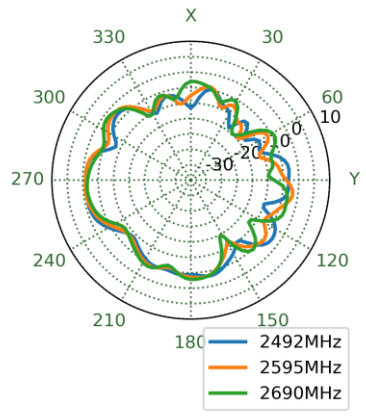
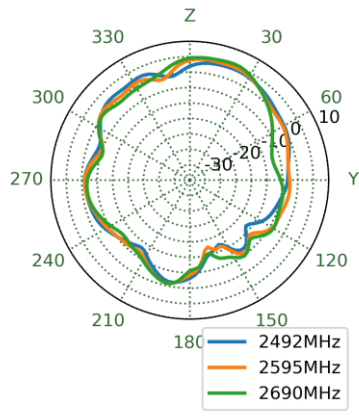
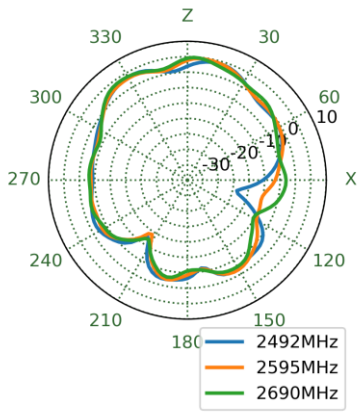

4.40 LTE 2 on 30x30cm Ground Plane - Patterns at 3550 MHz

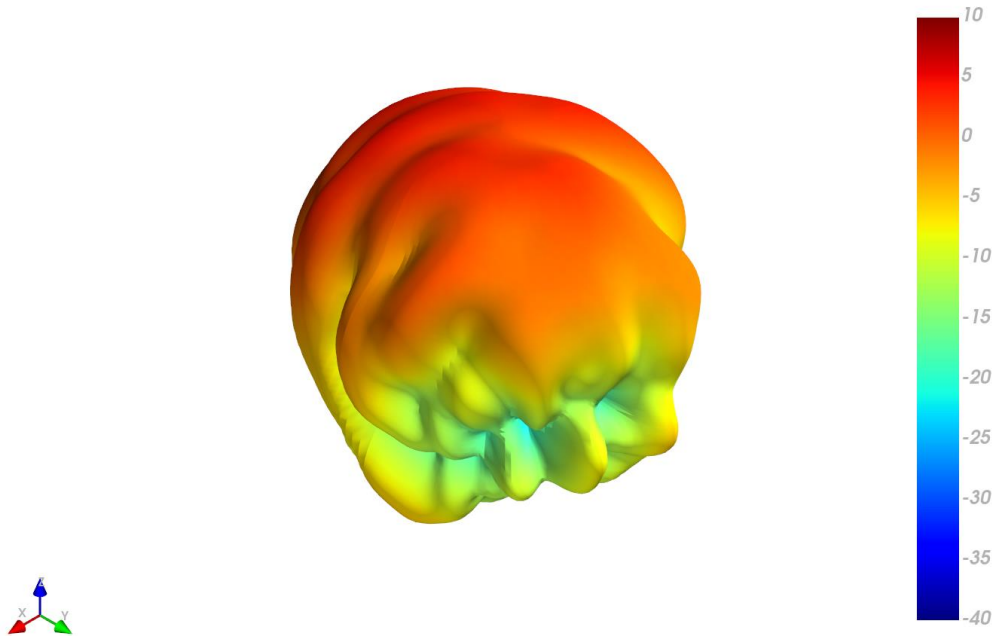

XZ Plane YZ Plane XY Plane

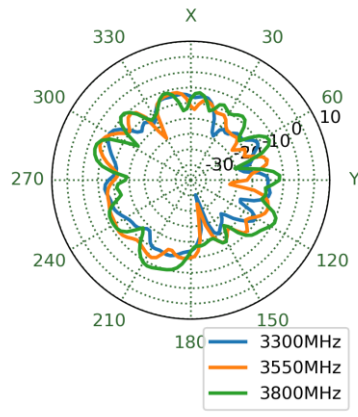
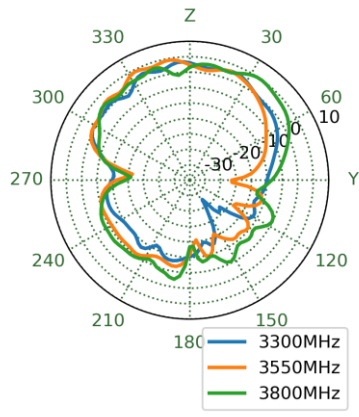
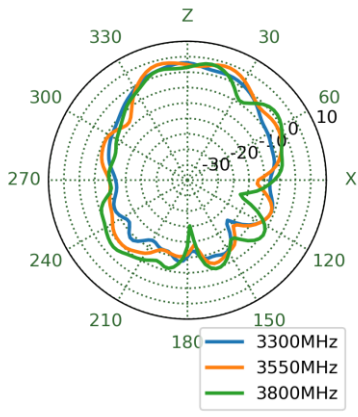

4.41 LTE 2 on 30x30cm Ground Plane - Patterns at 4800 MHz

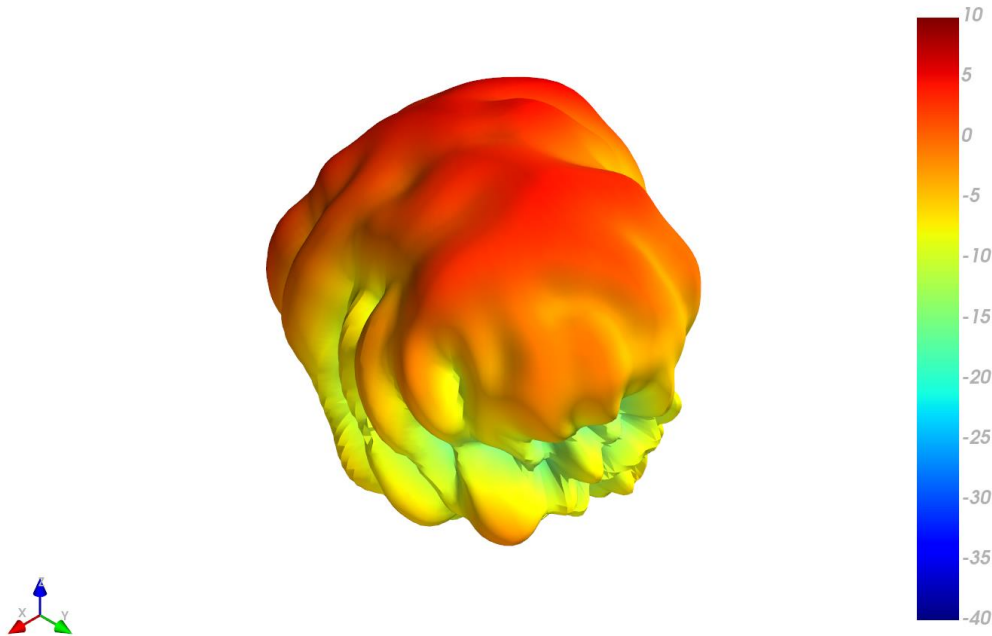

XZ Plane YZ Plane XY Plane

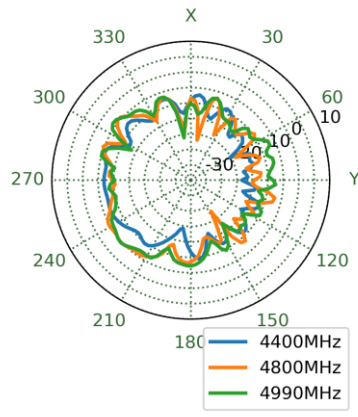
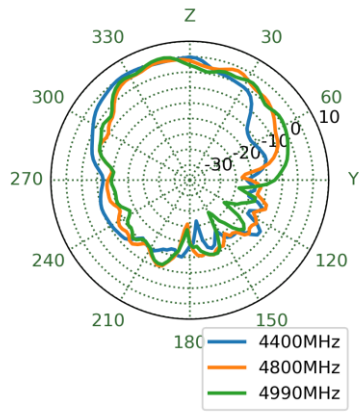
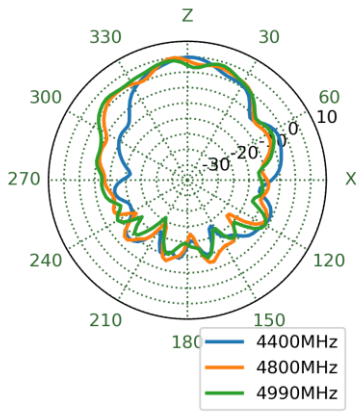

4.42 Wi-Fi in Free Space - Patterns at 2450 MHz

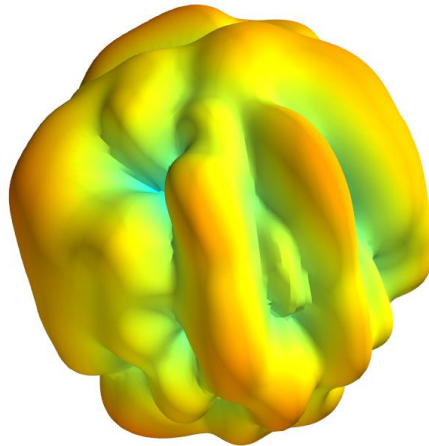

XZ Plane YZ Plane XY Plane

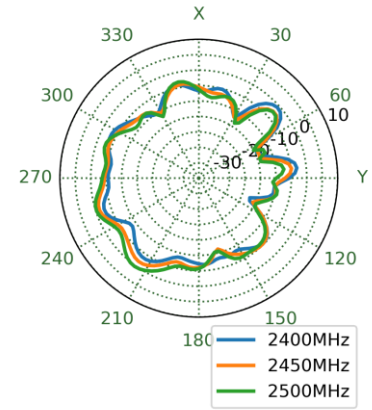
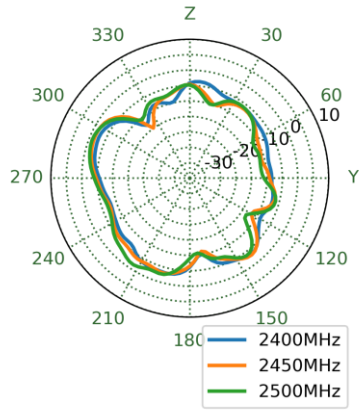
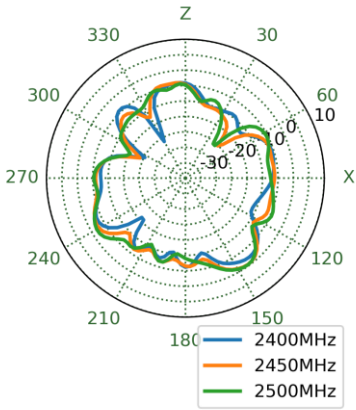

4.43 Wi-Fi in Free Space - Patterns at 5550 MHz

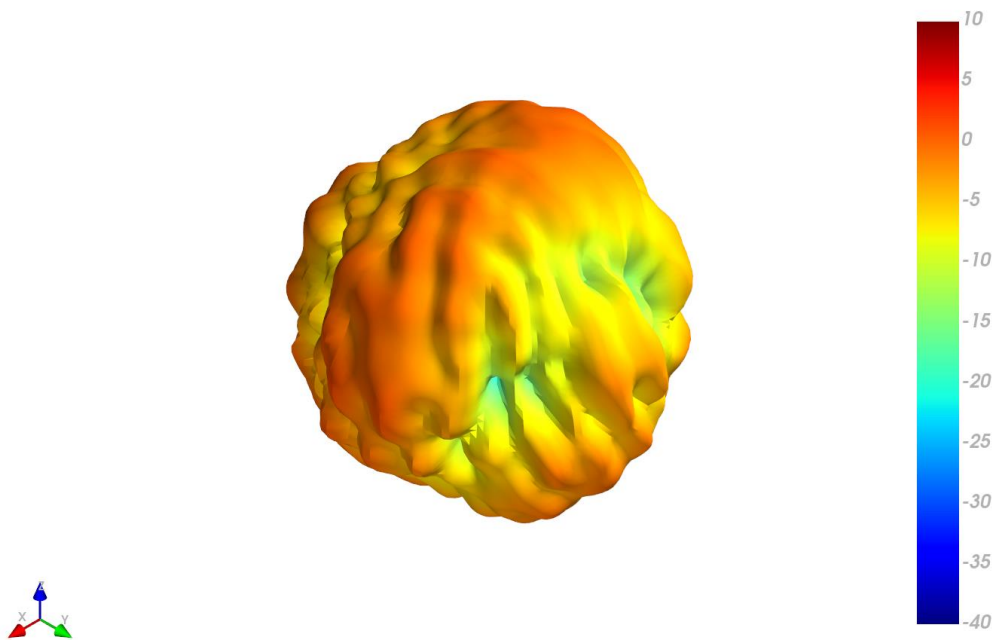

XZ Plane YZ Plane XY Plane

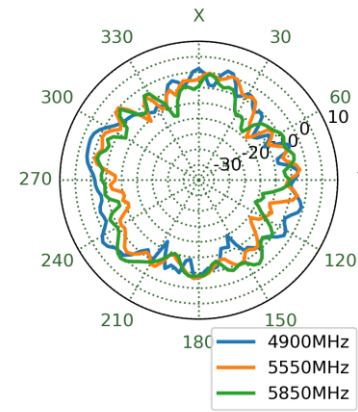
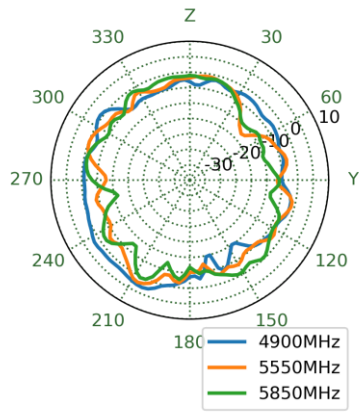
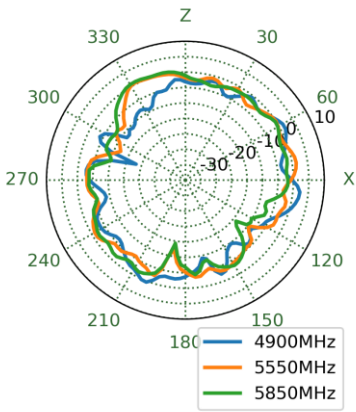

4.44 Wi-Fi in Free Space - Patterns at 6475 MHz

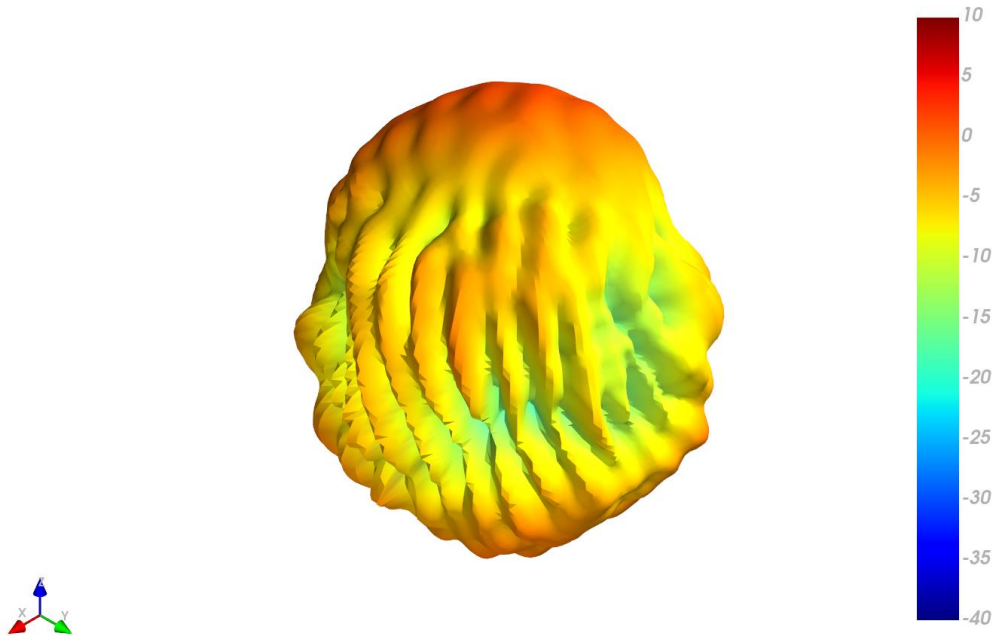

XZ Plane YZ Plane XY Plane

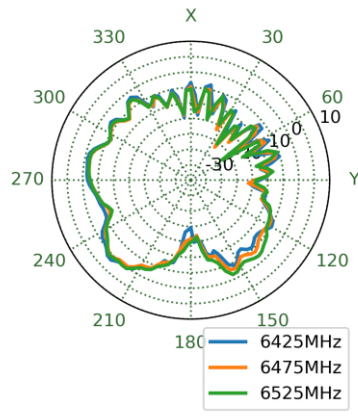
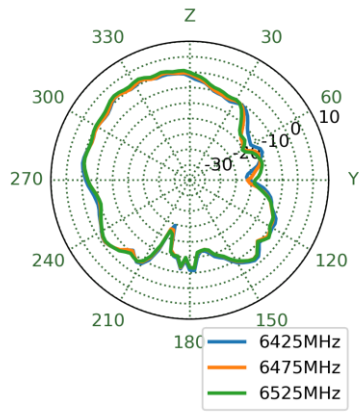
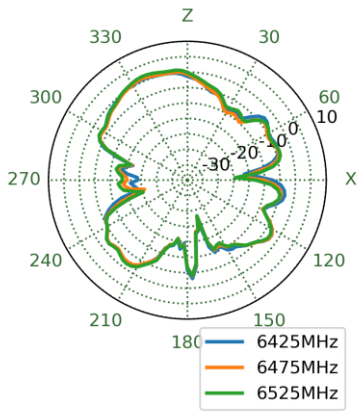

4.45 Wi-Fi in Free Space - Patterns at 7000 MHz

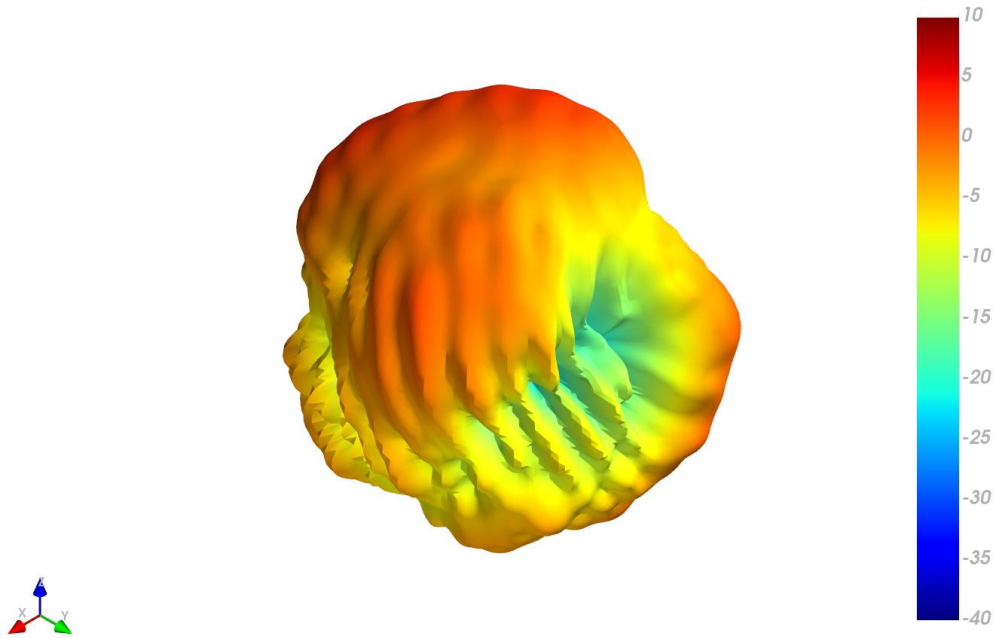

XZ Plane YZ Plane XY Plane

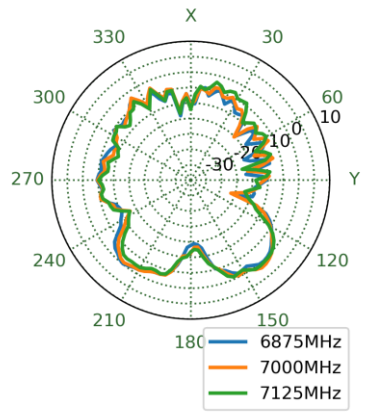
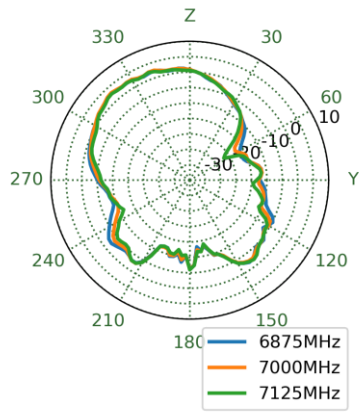
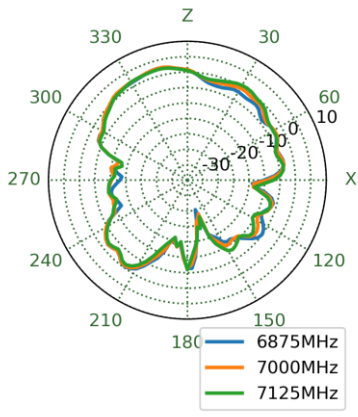

4.46 Wi-Fi on 30x30cm Ground Plane - Patterns at 2450 MHz

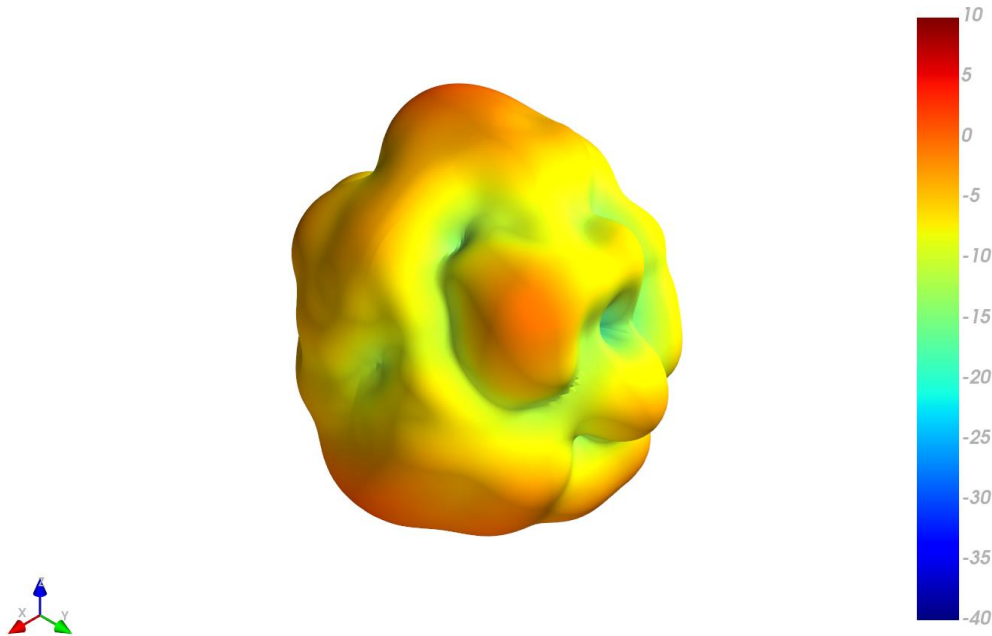

XZ Plane YZ Plane XY Plane

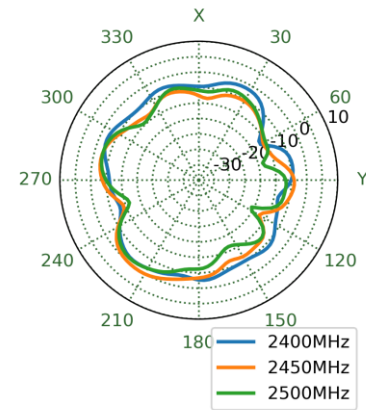
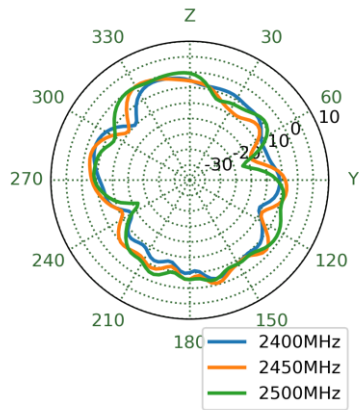
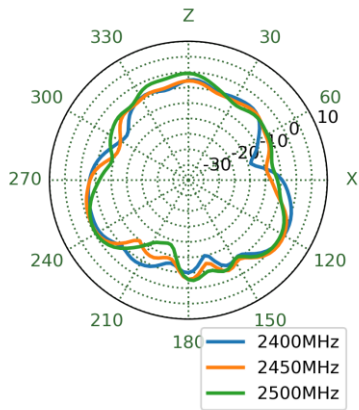

4.47 Wi-Fi on 30x30cm Ground Plane - Patterns at 5550 MHz

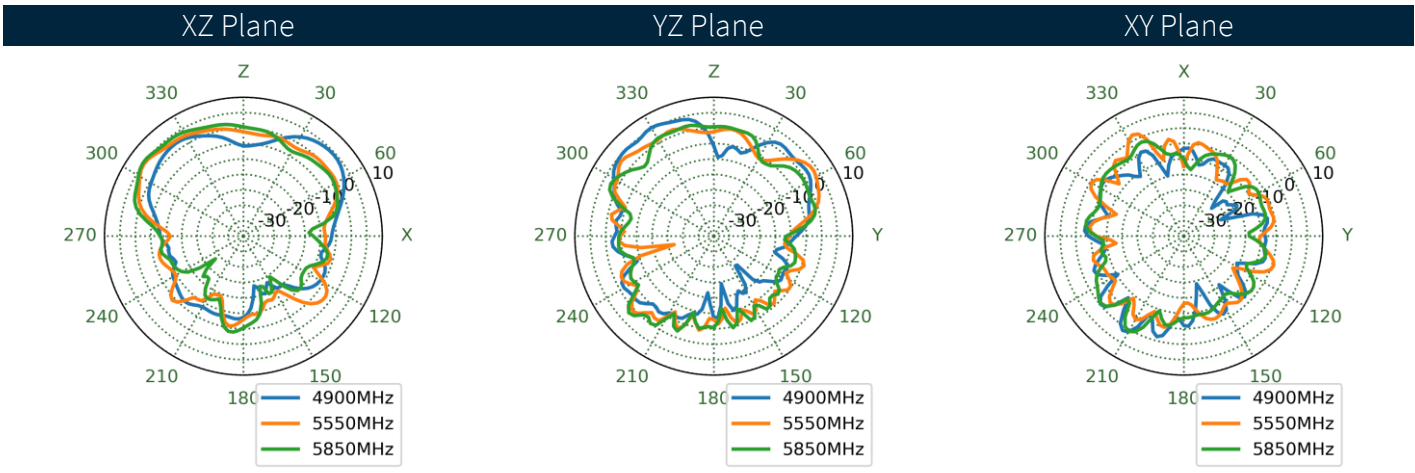
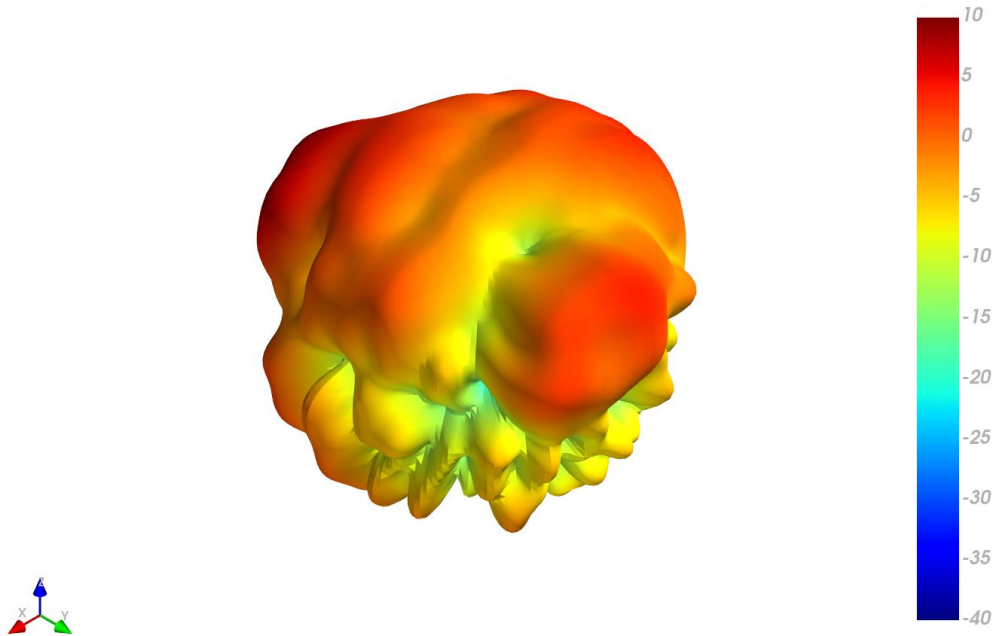

4.48 Wi-Fi on 30x30cm Ground Plane - Patterns at 6475 MHz

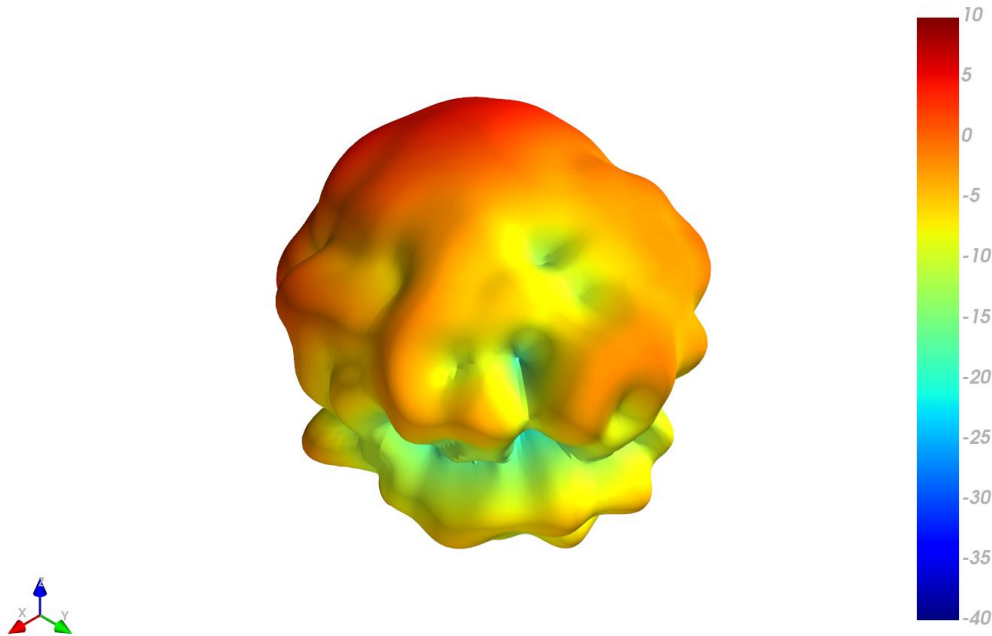

XZ Plane YZ Plane XY Plane

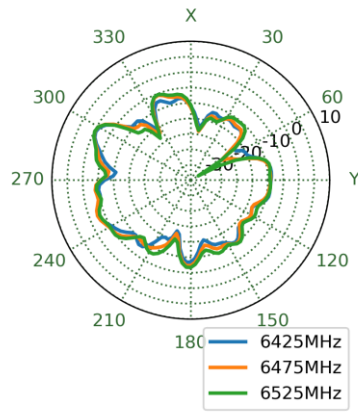
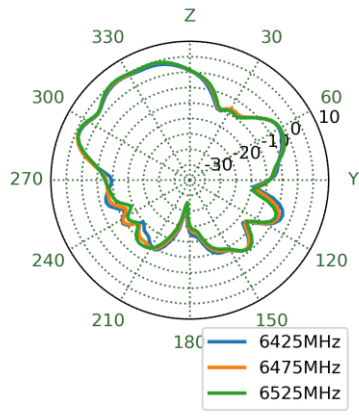
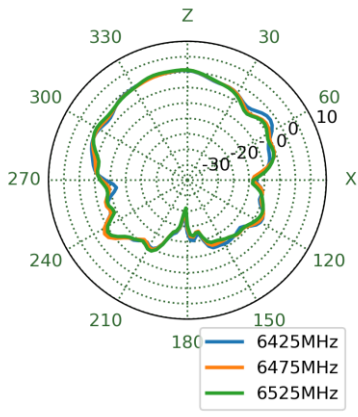

4.49 Wi-Fi on 30x30cm Ground Plane - Patterns at 7000 MHz

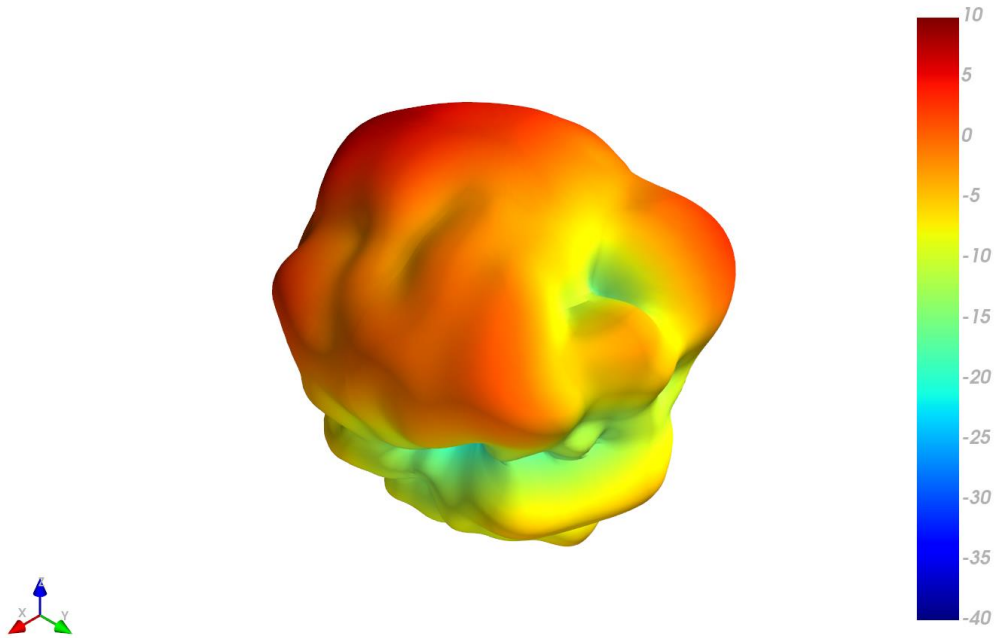

XZ Plane YZ Plane XY Plane

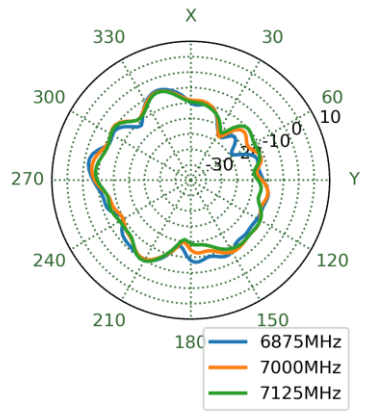
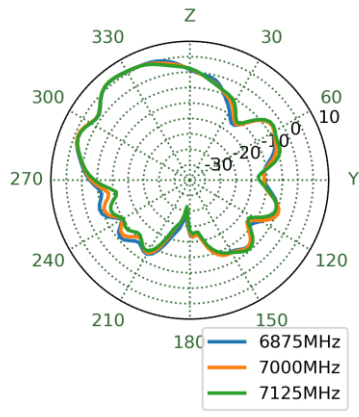
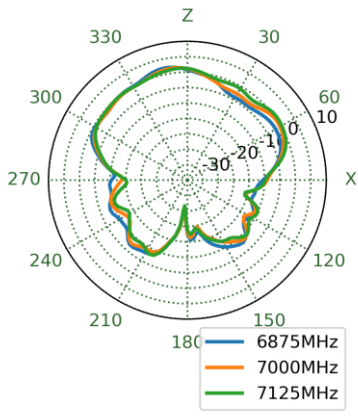

5. Mechanical Drawing

ISO NO.: EDW-23-8-0279

STATE: RELEASE

NOTES: 1. ALL MATERIAL MUST BE ROHS COMPLIANT.

REV	ZONE	DESCRIPTION	ENG	APPROVED	DATE
D01	All	Initial design	G. Samson	I. Mendez	4/3/2023

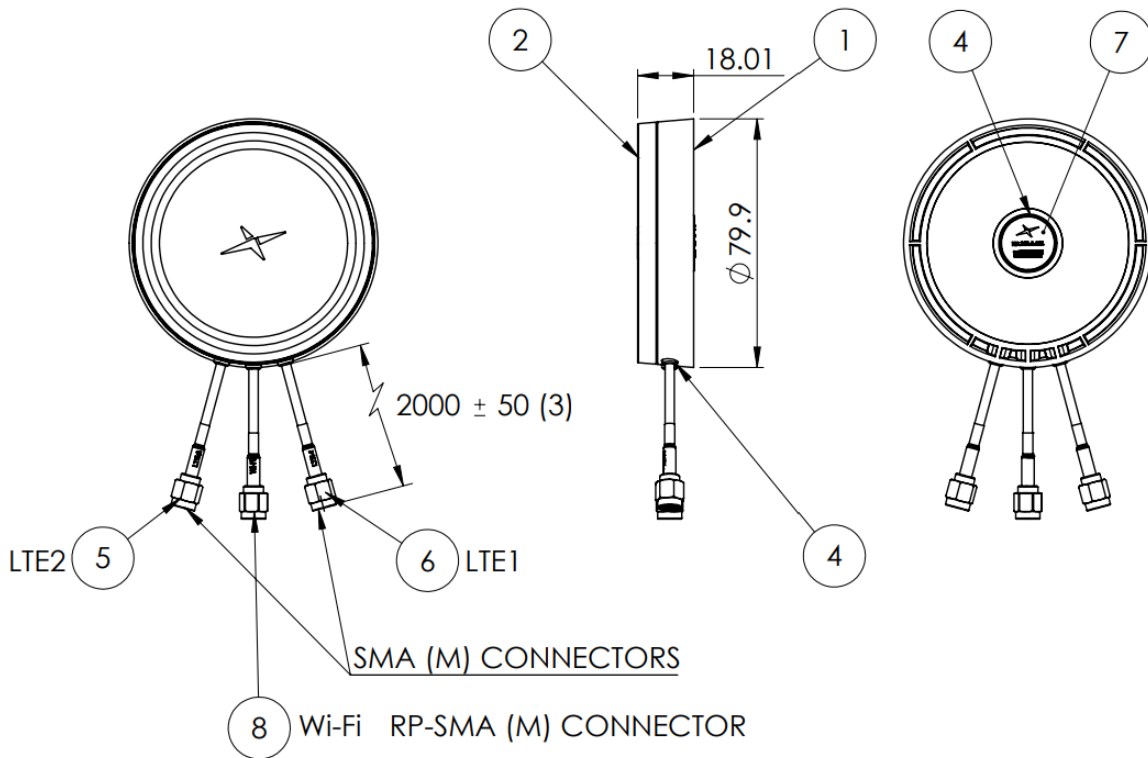

FN	DESCRIPTION	MATERIAL	FINISH	QTY.
1	Bottom Housing 3 Hole	ASA	Black	1
2	Top Housing	ASA	Black	1
3	Cable Grommet 1.5DS	Silicone	Black	3
4	Magnet pack/N48	N48	Ni Plated	1
5	Cable Assy 2m 1.5DS LTE2	NA	NA	1
6	Cable Assy 2m 1.5DS LTE1	NA	NA	1
7	Product Label MA323.A.001	Polyester	NA	1
8	Cable Assy 2m 1.5DS WiFi	NA	NA	1

APPROVED BY: N. Baird	<p><small>This drawing is Taoglas Confidential information and its inherent design concepts are property of Taoglas. This is not to be copied or shared with third parties without the prior written consent of Taoglas.</small></p>
CHECK BY: I. Mendez	
DRAWN BY: G. Samson	
DATE: 4/3/2023	TITLE: 3 in 1 2*4G MIMO & Wifi Adhesive/Mag Mt Puck Antenna w 2m 1.5DS and SMA(M)
UNLESS OTHERWISE SPECIFIED TOLERANCES ON: XX±0.5 X±0.3 X±0.2 XXX±0.1 XXXX±0.05	PART NO.: MA323.A.001
THIRD ANGLE PROJECTION	UNIT: mm SCALE: 1:2 PAGES: 1/1 REV: D01

6. Packaging



☑ 1 PCS Tape / Small PE Bag



☑ 1 PCS / PE Bag



- ☑ 70 PCS / Carton
- ☑ 2 PCS Carton board
- ☑ Carton(mm): 355*355*275mm
- ☑ Carton Label

7. Application Note

This application note shows the performance of the MA323.A.001 with 2meters of 1.5SDS.

7.1 Return Loss

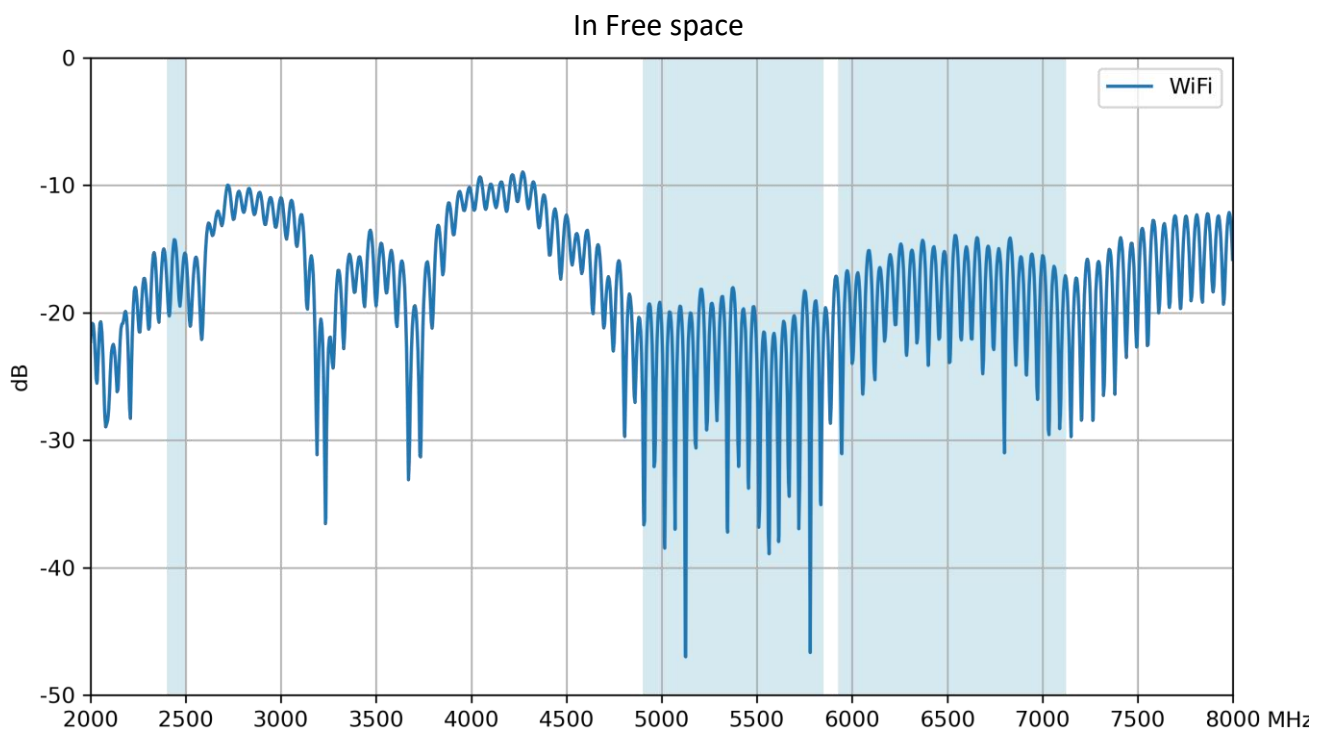
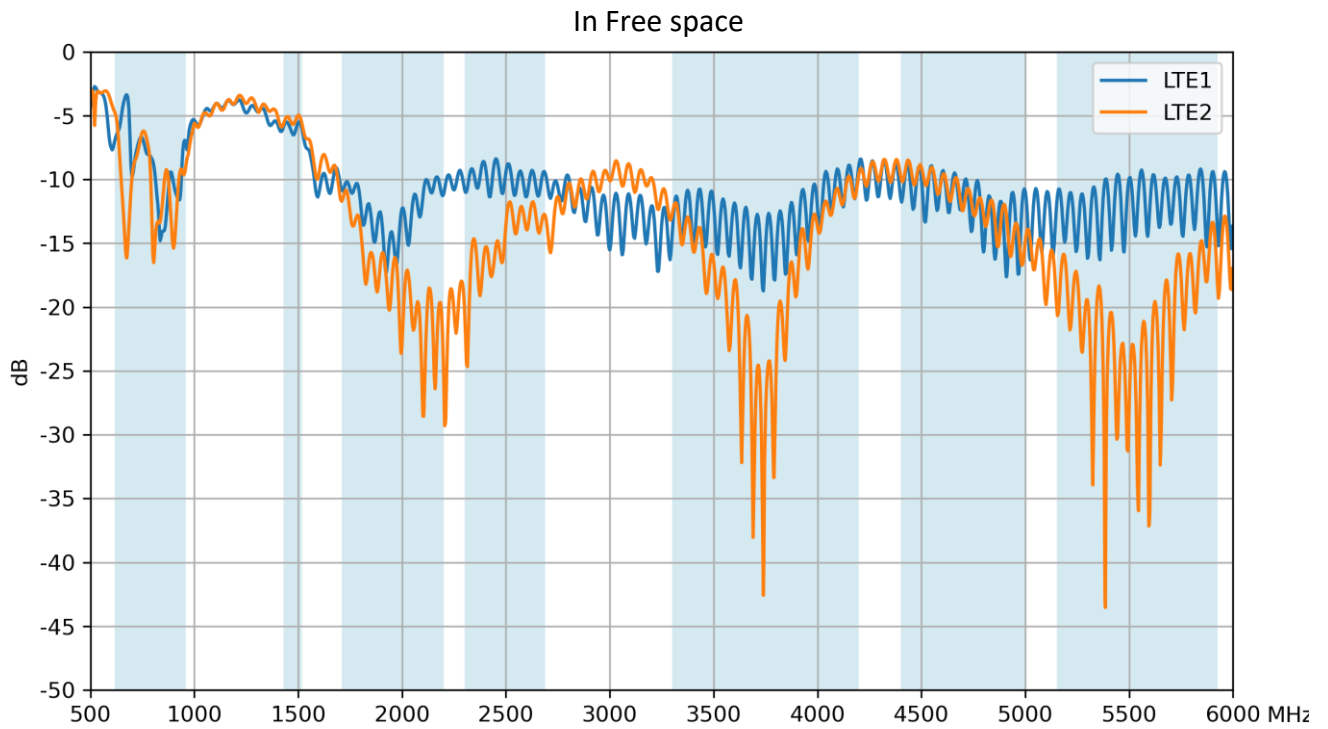

on 30x30cm Ground plane

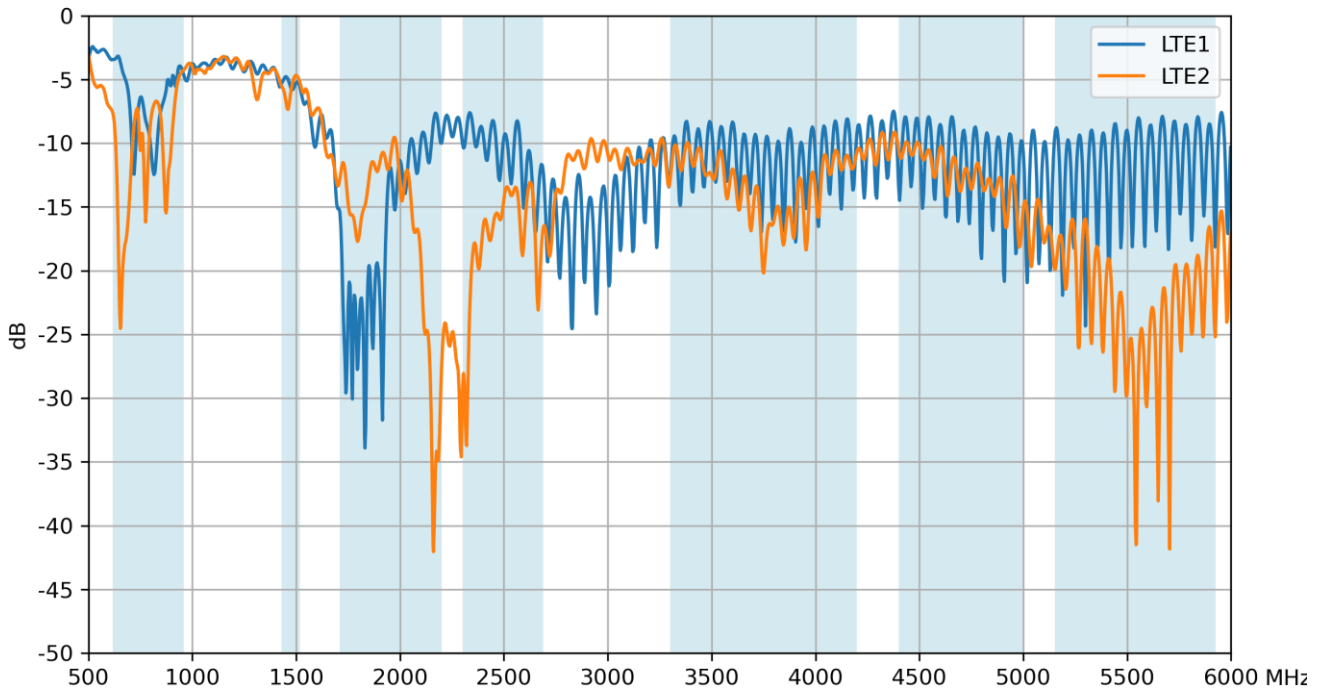

on 30x30cm Ground plane

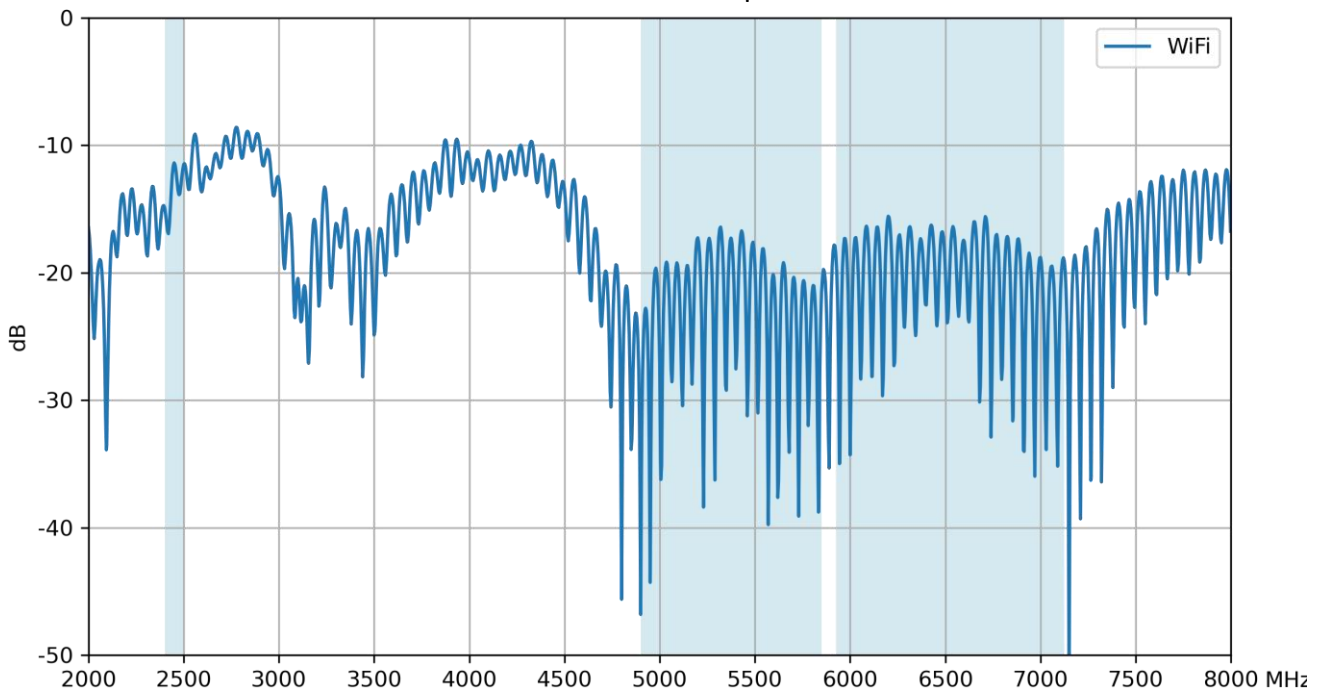

7.2 Isolation

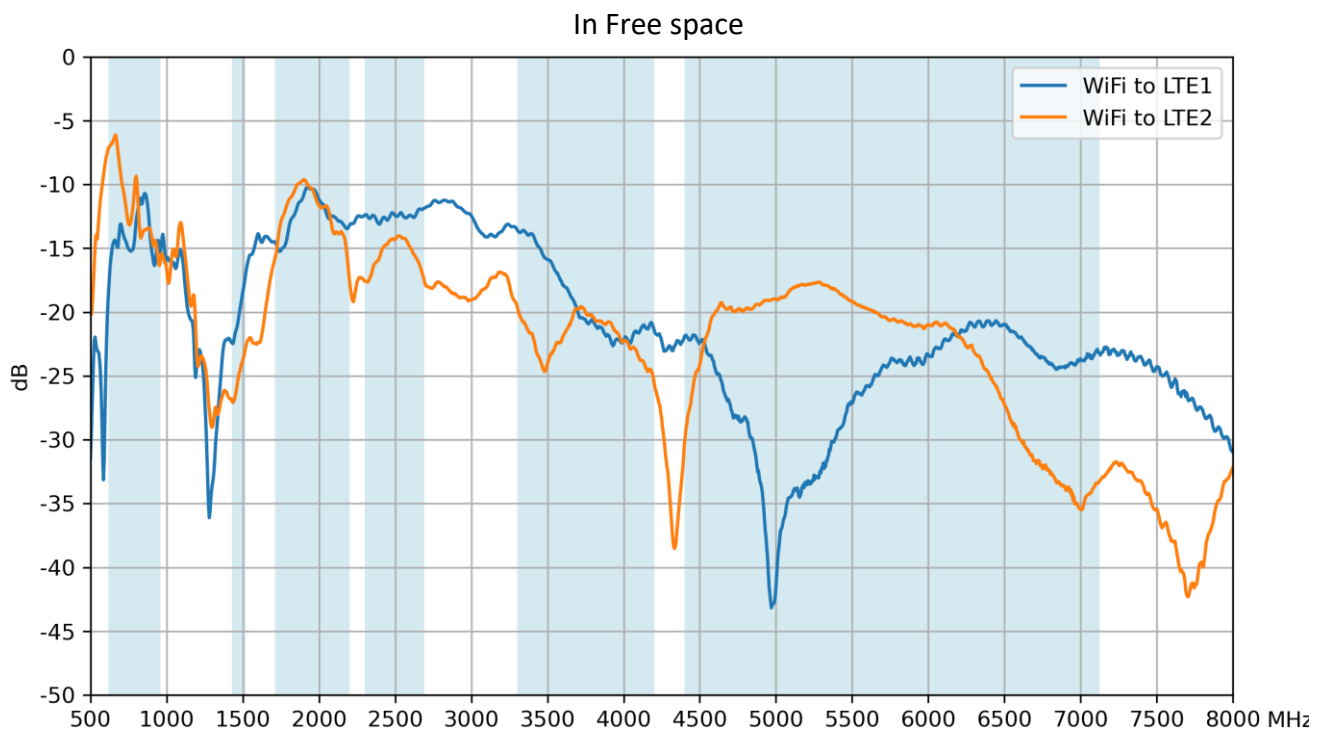
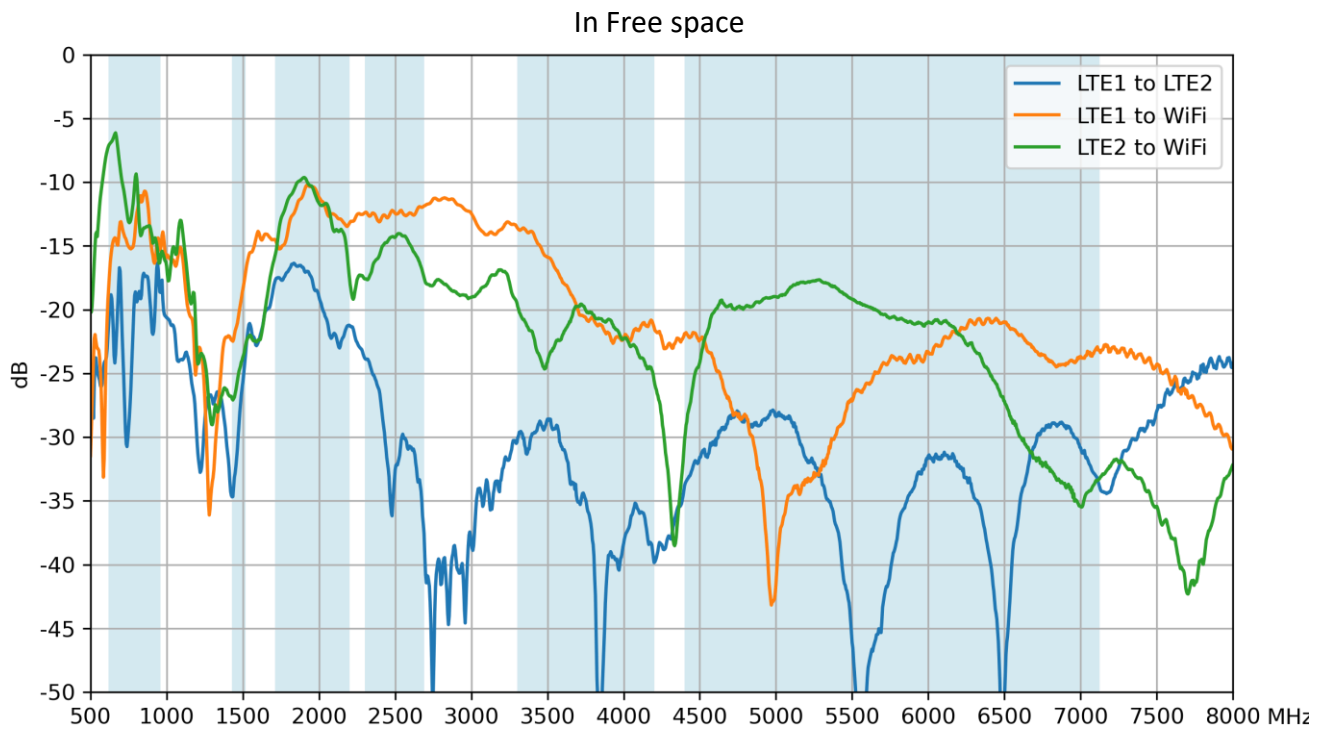

on 30x30cm Ground plane

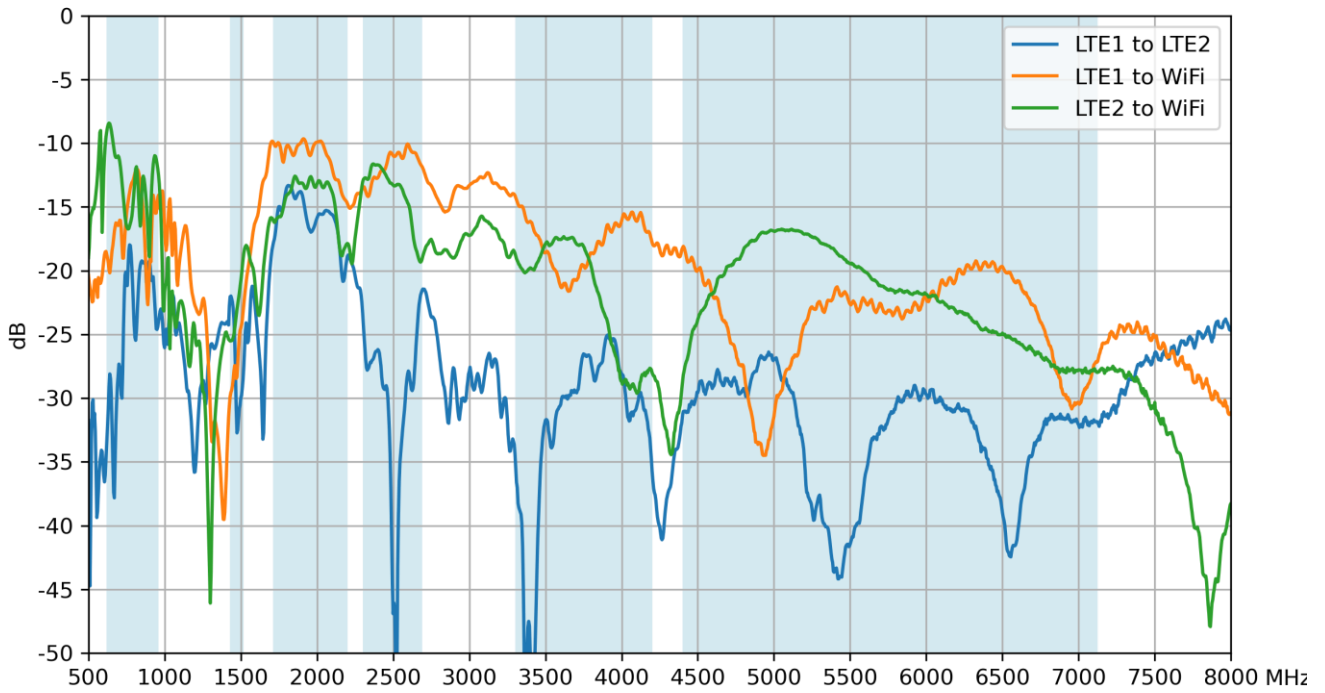

on 30x30cm Ground plane

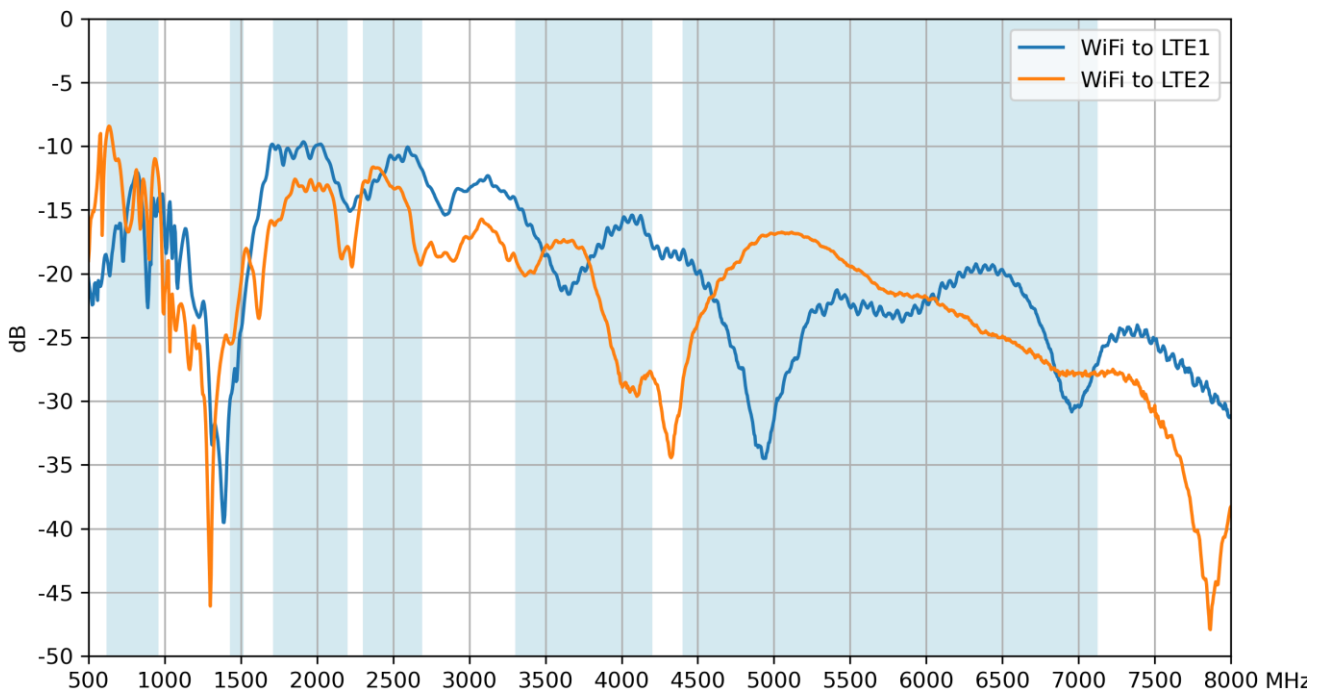

7.3 LTE - Efficiency

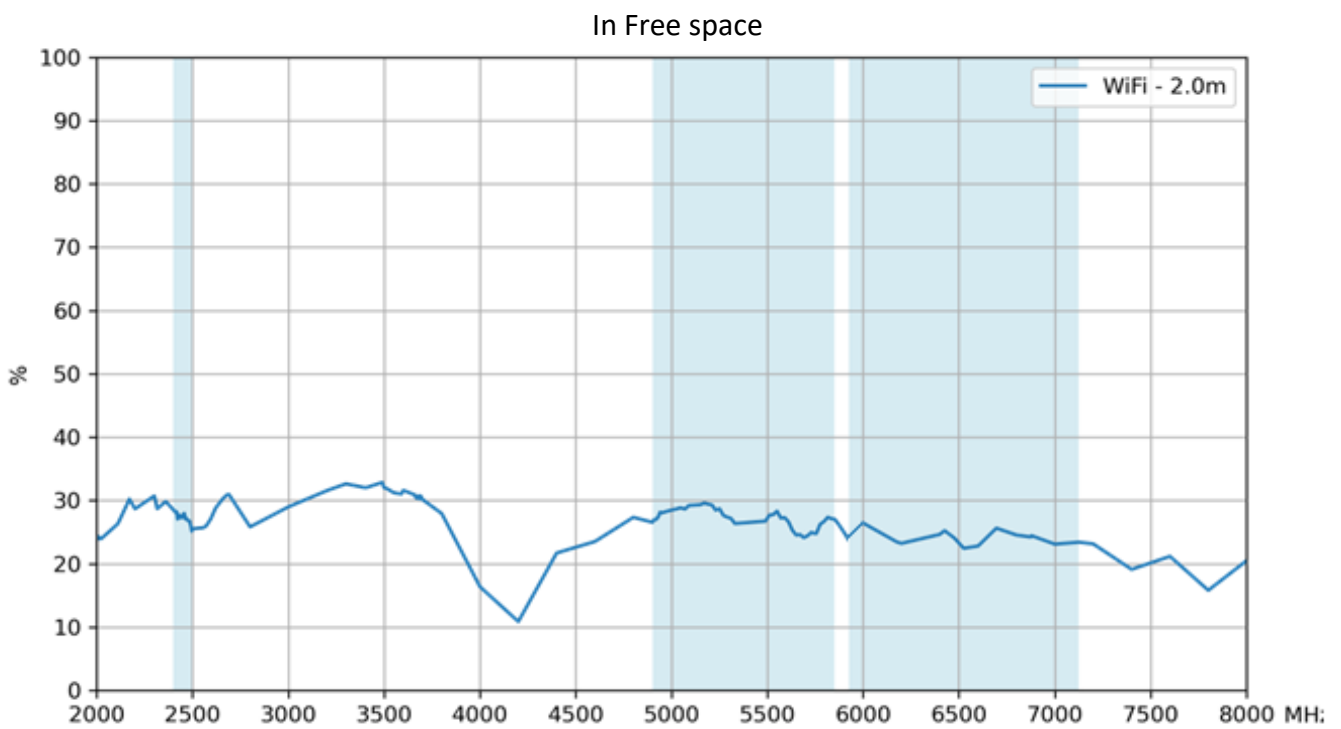
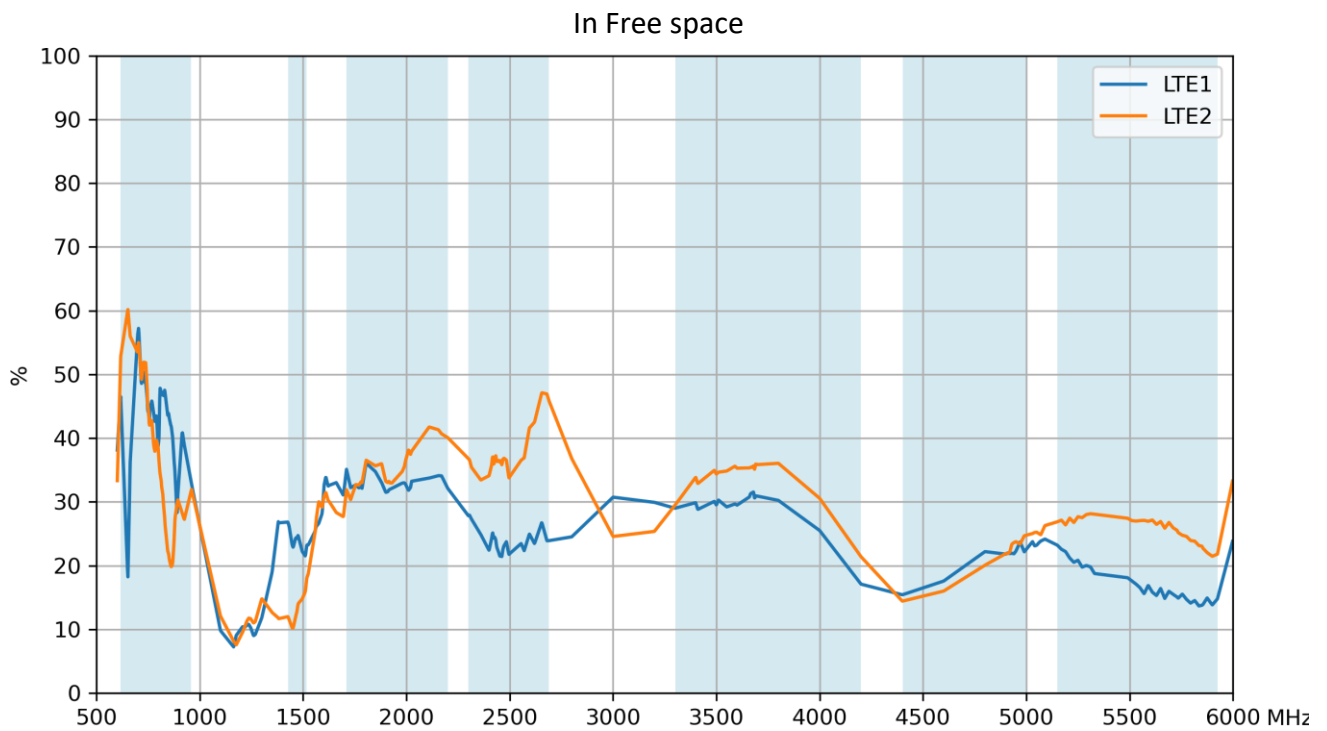

on 30x30cm Ground plane

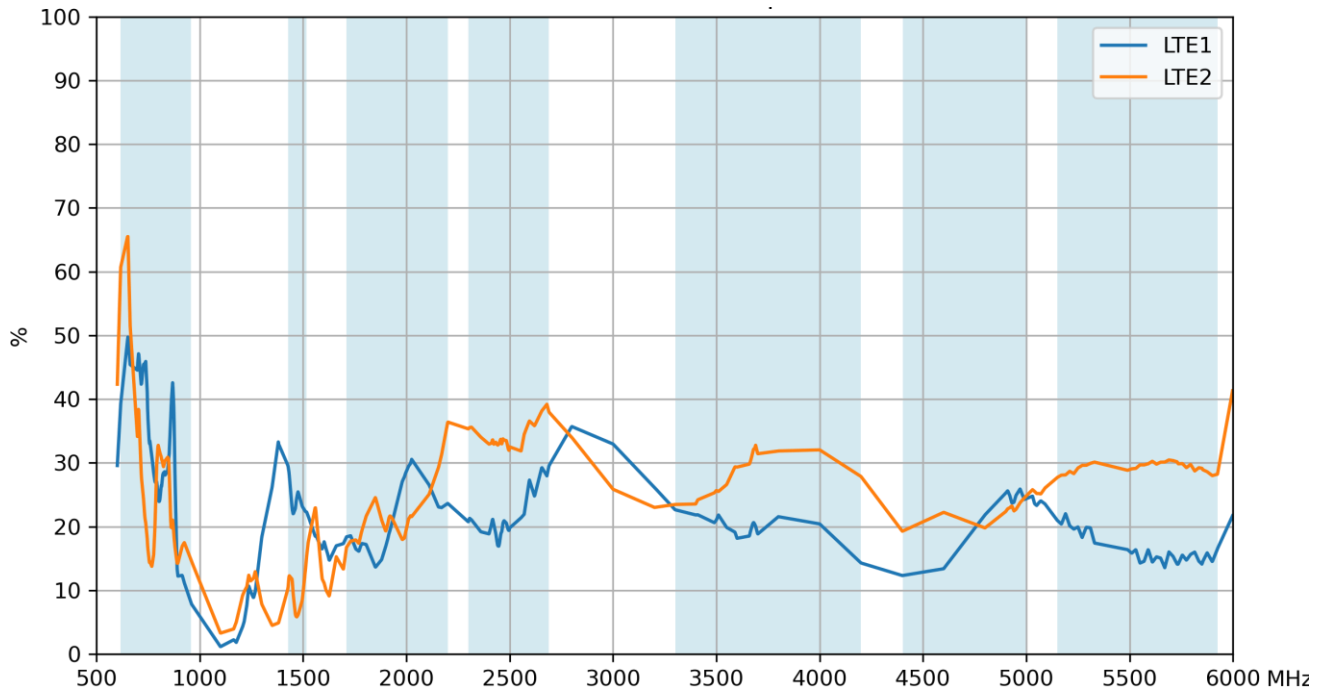

on 30x30cm Ground plane

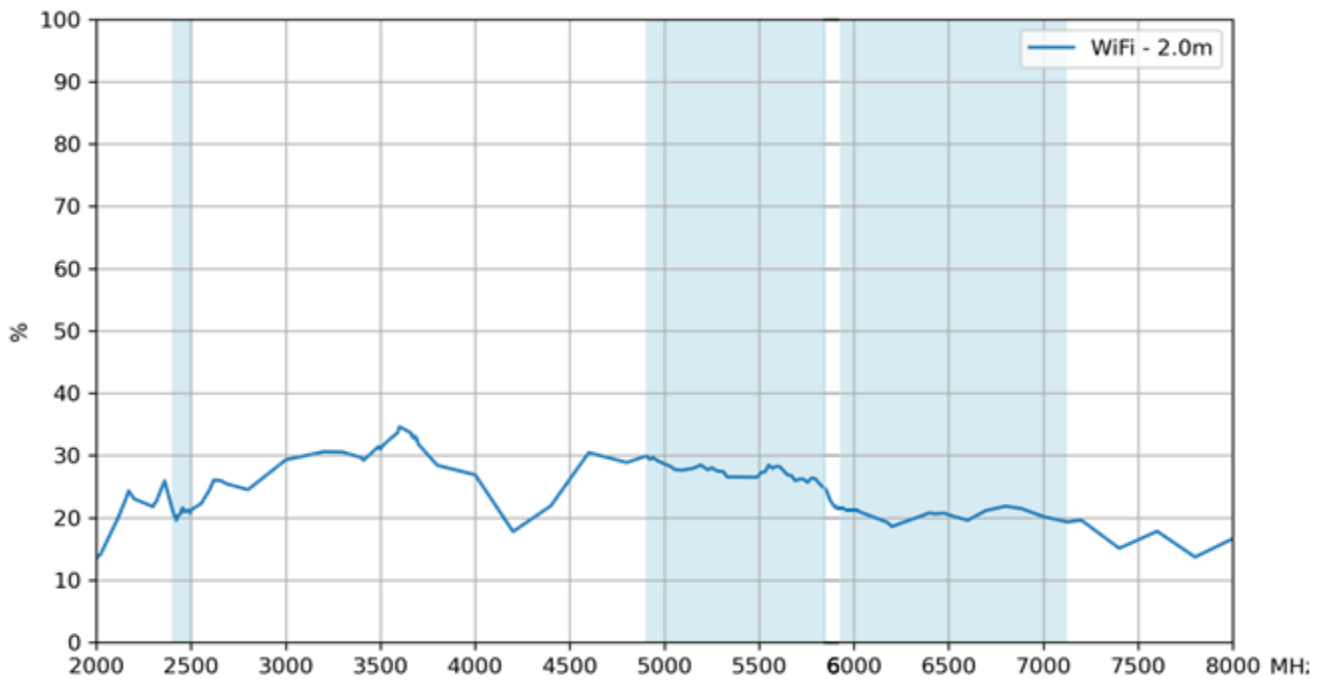

7.4 LTE - Average Gain

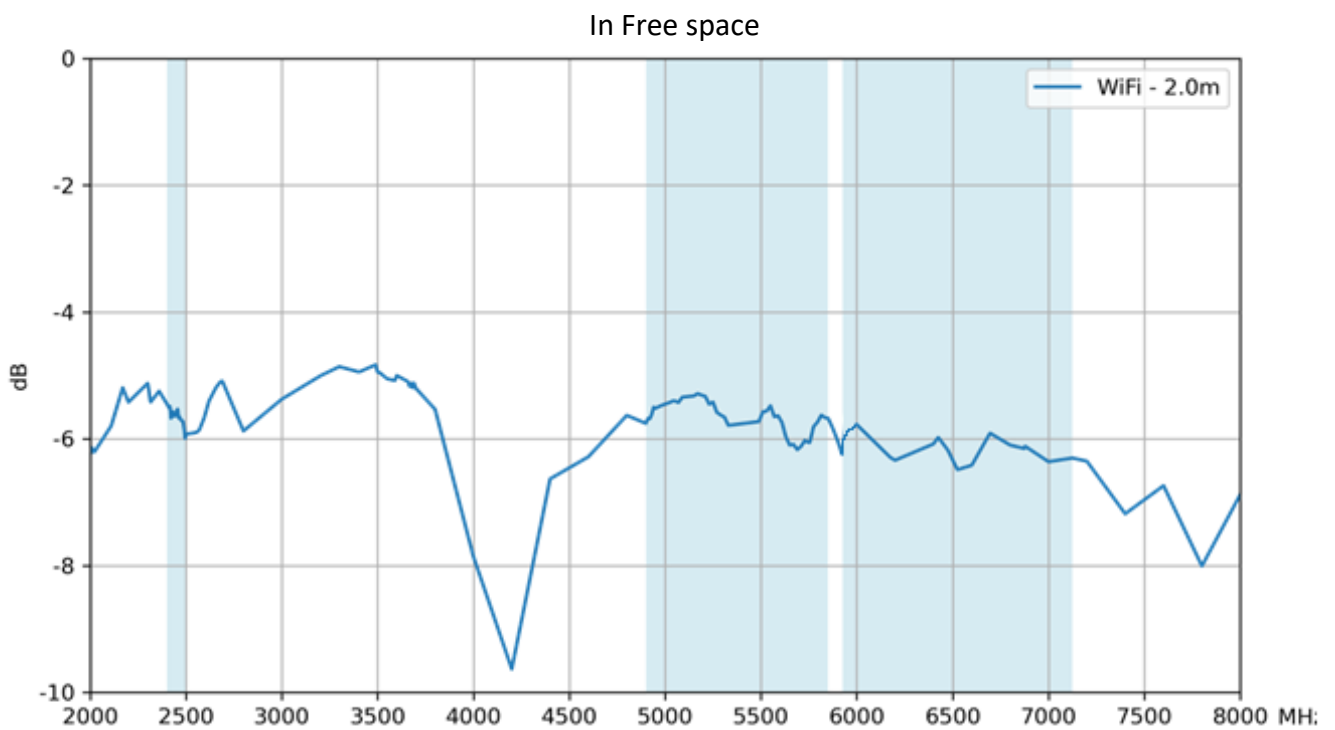
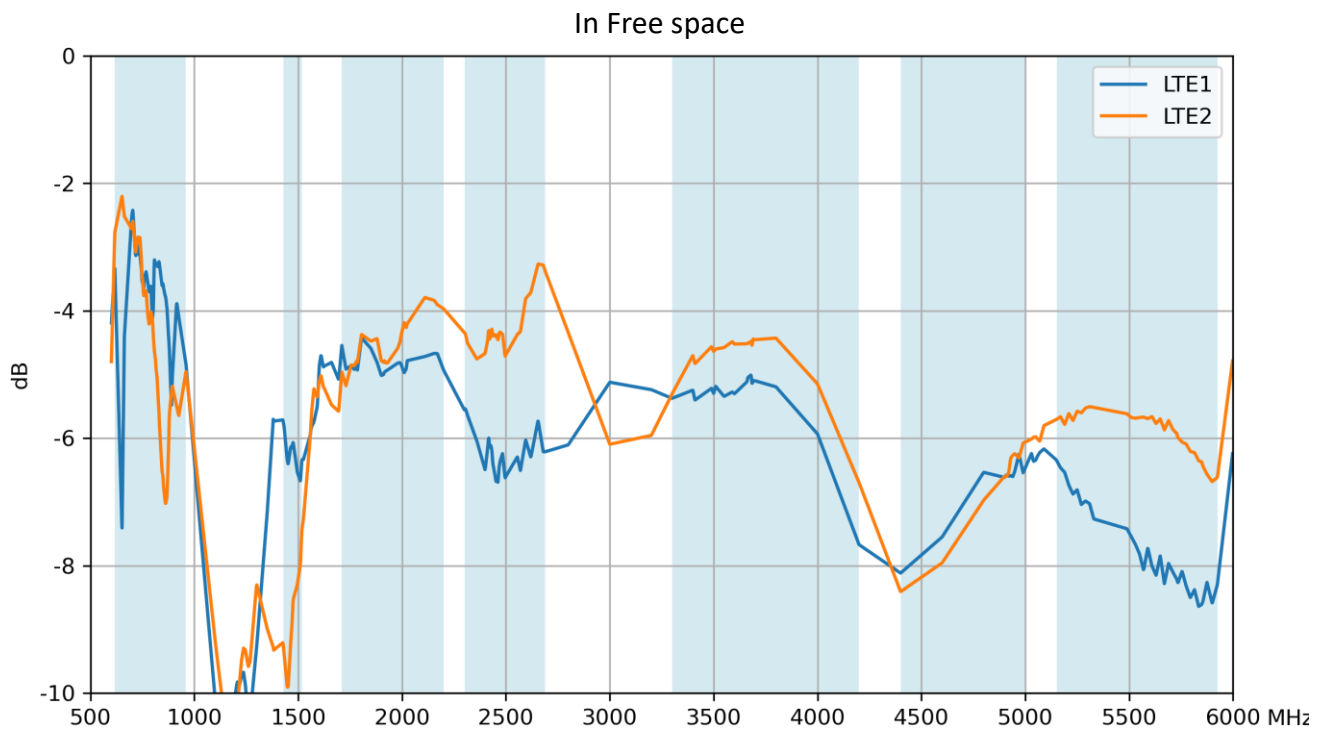

on 30x30cm Ground plane

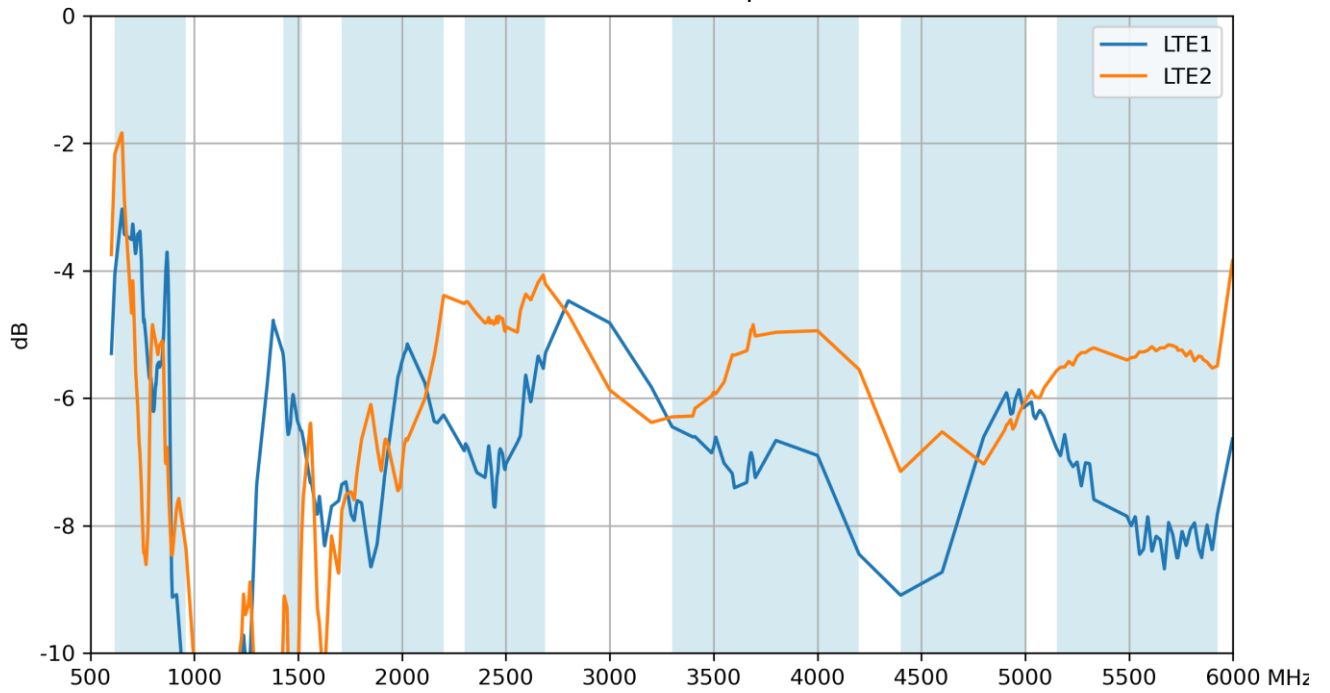

on 30x30cm Ground plane

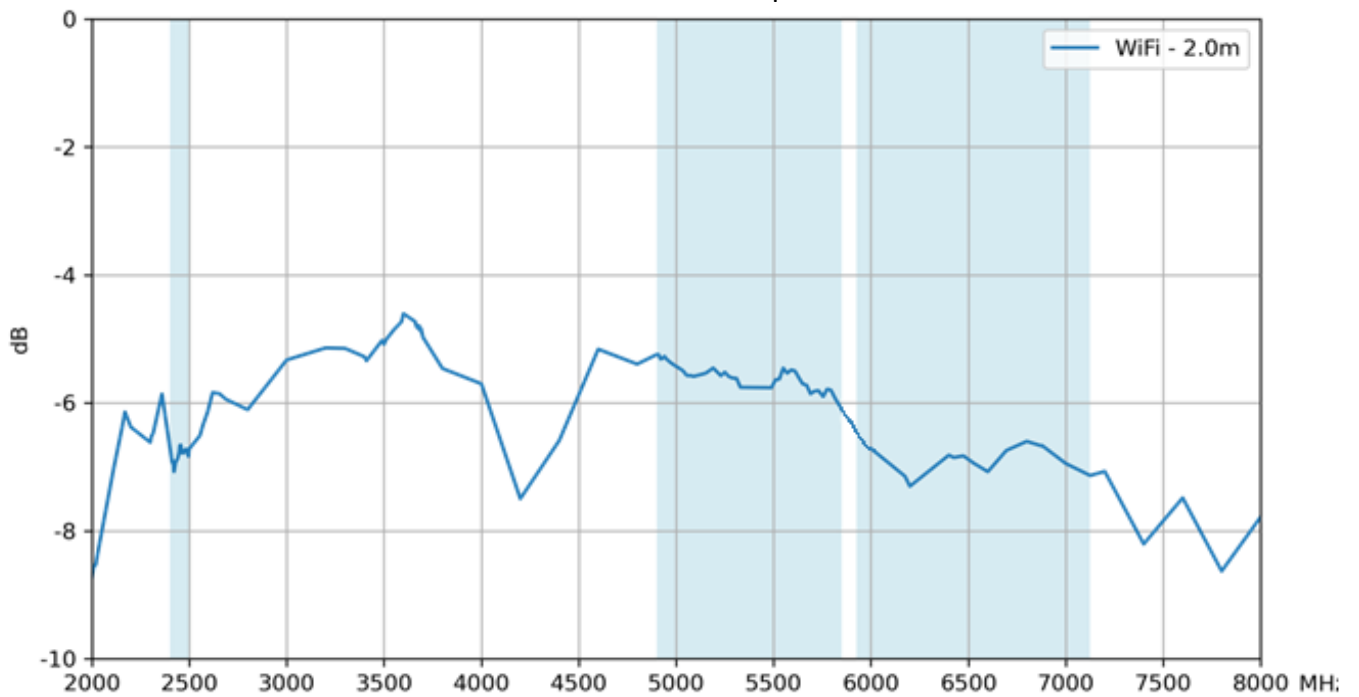

7.5 LTE - Peak Gain

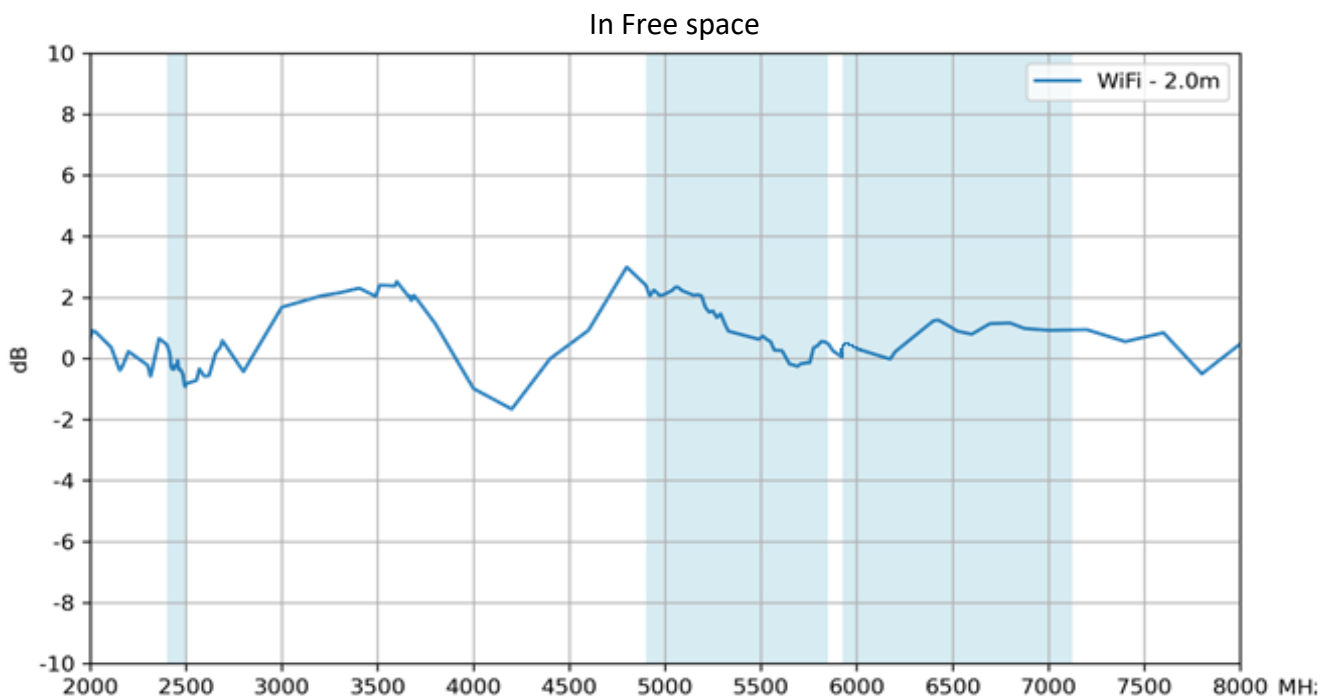
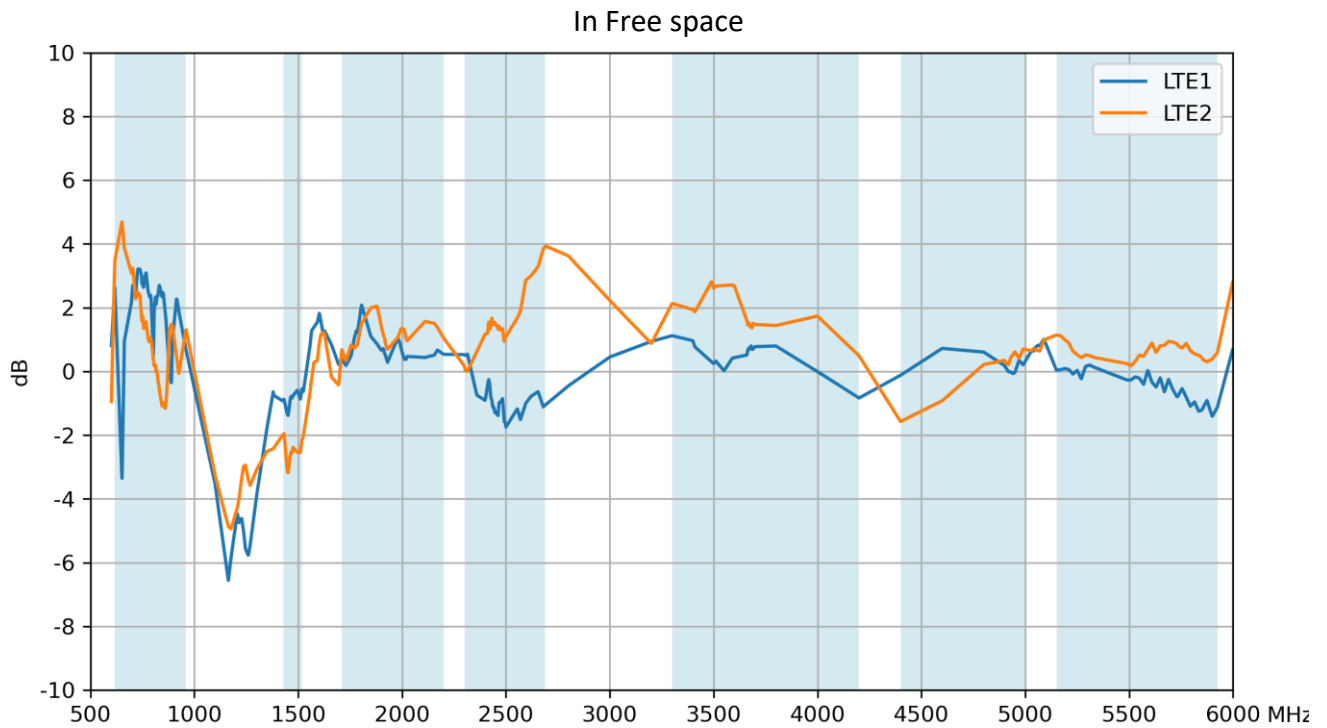

on 30x30cm Ground plane

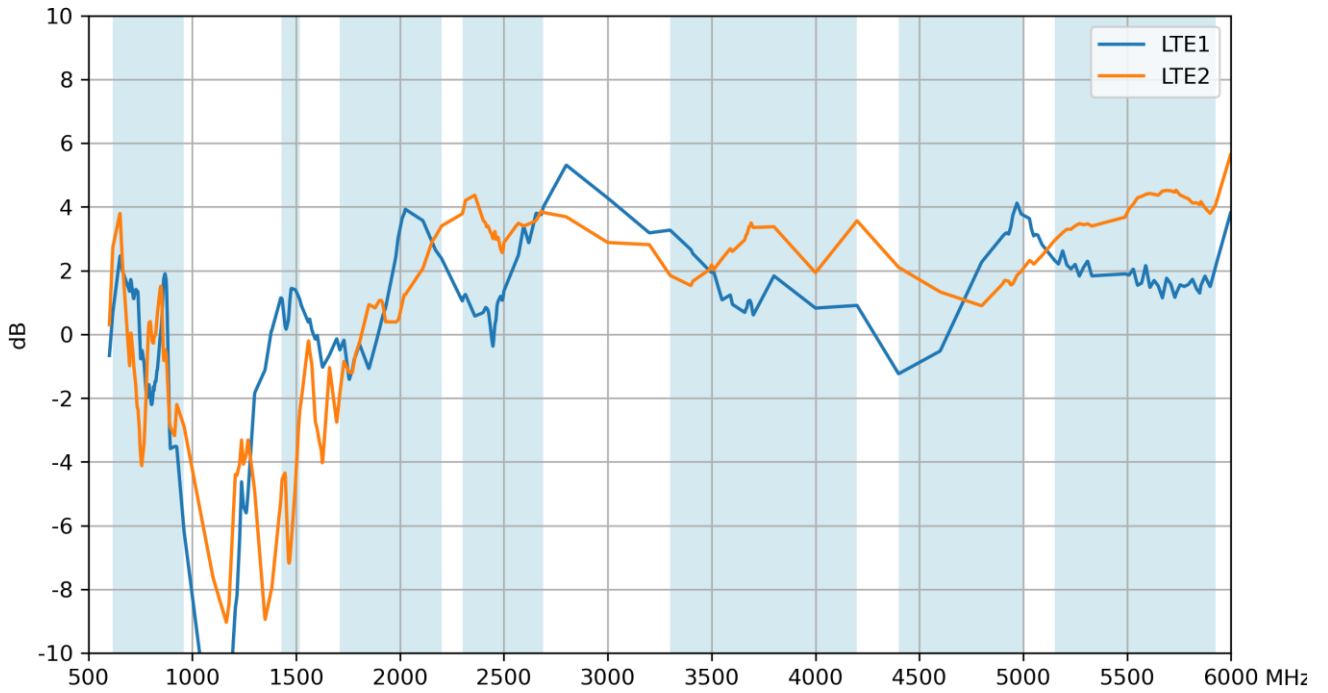

on 30x30cm Ground plane

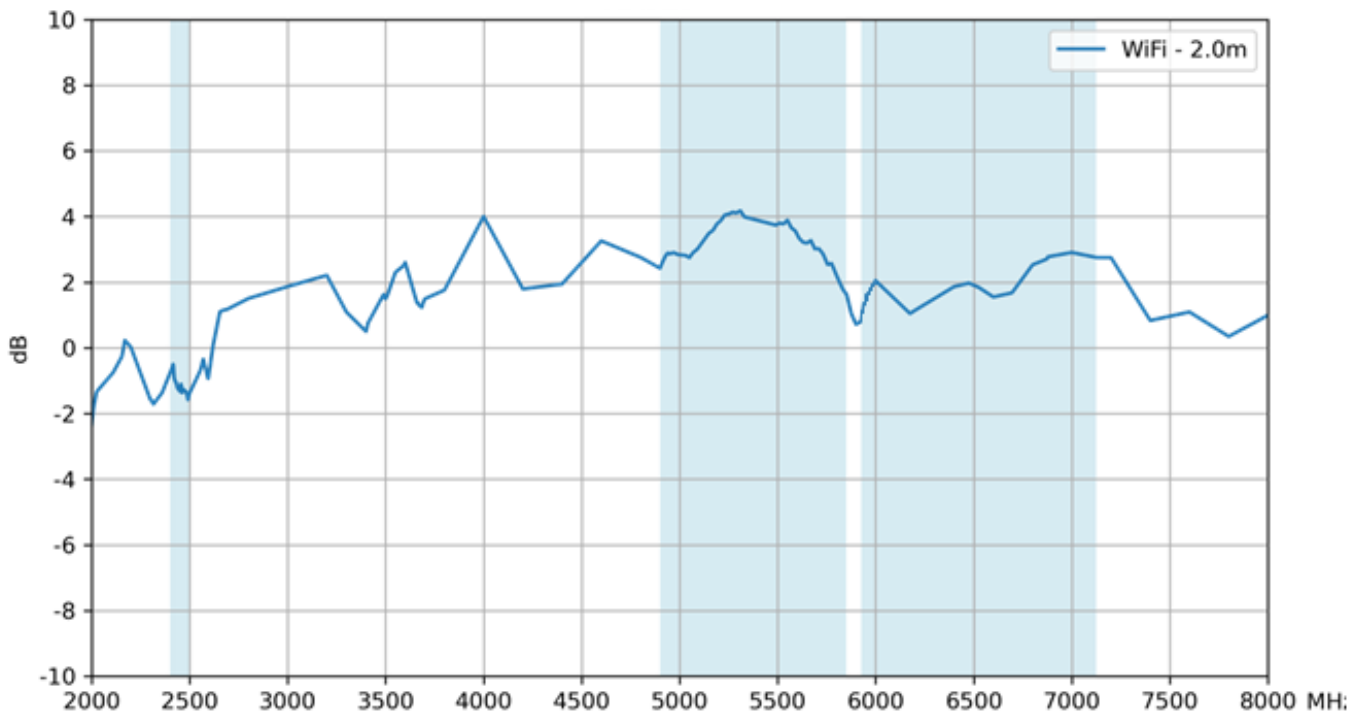

Changelog for the datasheet

SPE-23-8-218 - MA323.A.001

Revision: A (Original First Release)	
Date:	2023-07-24
Notes:	Initial Release
Author:	Gary West

Previous Revisions



www.taoglas.com

