



TAOGLAS®



Datasheet

Part No:
MB.A.MX2

Description

Screw Mount Bracket for MagmaX AA.200 Series

Features:

Screw Mount

Hole Dimensions: \varnothing 5.05mm

Dimensions: 102 x 74 x 23mm

RoHS & REACH Compliant

| | | |
|----|--------------------|---|
| 1. | Introduction | 2 |
| 2. | Specification | 3 |
| 3. | Mechanical Drawing | 4 |
| 4. | Packaging | 5 |

Taoglas makes no warranties based on the accuracy or completeness of the contents of this document and reserves the right to make changes to specifications and product descriptions at any time without notice. Taoglas reserves all rights to this document and the information contained herein. Reproduction, use or disclosure to third parties without express permission is strictly prohibited.



1. Introduction



The Taoglas MB.A.MX2 is a robust screw mount bracket, designed for secure installation of the MagmaX AA.200 Series where a bracket is the preferred method of mounting the antenna. The MagmaX AA.200 Series, can be used with this bracket allowing it to be mounted on surfaces where a permanent through hole mount is needed.

Configurations are available to suit your mounting requirements:

- Screw Mount

Contact your regional Taoglas customer support team for further information. This bracket is fully compatible with all of our standard [MagmaX AA.200](#).

2. Specification

| Mechanical | |
|-----------------------|----------------------------|
| Dimensions | 102 x 74 x 23mm |
| Material | ABS PC/Nickel Plated Brass |
| Bracket weight | 26g |
| Environmental | |
| Operation Temperature | -40°C ~ +85°C |
| Storage Temperature | -40°C ~ +90°C |

3. Mechanical Drawing

ISO NO.: EDW-23-8-0249
 STATE: RELEASE
 NOTES: 1.ALL MATERIAL MUST BE ROHS COMPLIANT.

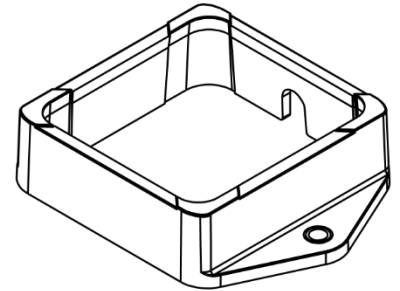

MODEL VIEW

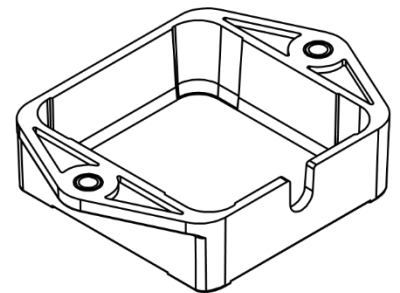
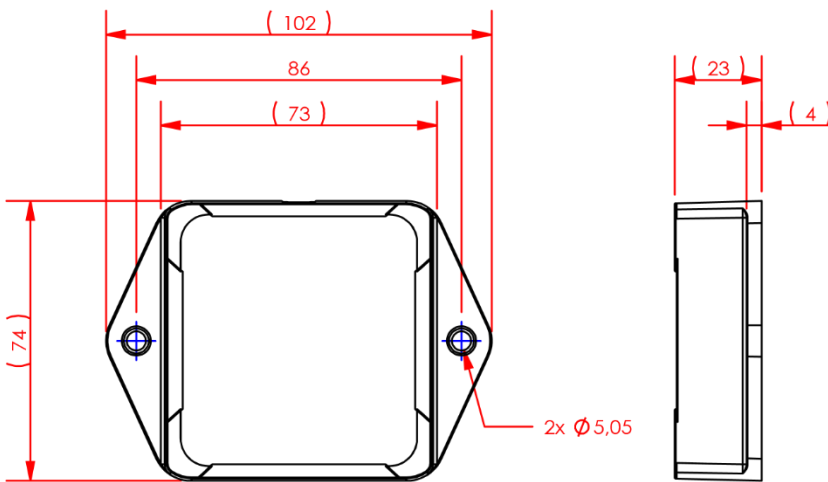

MODEL VIEW

| ITEM NO. | DESCRIPTION | QTY |
|----------|------------------------------|-----|
| 1 | AA.200 (NOT INCLUDED) | 1 |
| 2 | AA2xx Series Bracket Plastic | 1 |

INSTALLATION INSTRUCTIONS

4. Packaging

MB.A.MX2
1 pcs / Small PE Bag

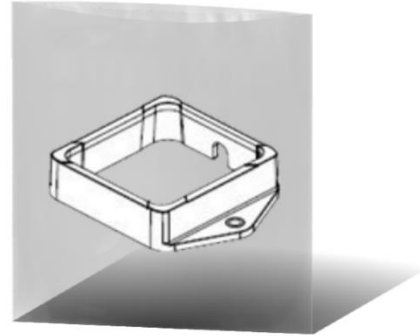

21 pcs/ Zipper bag

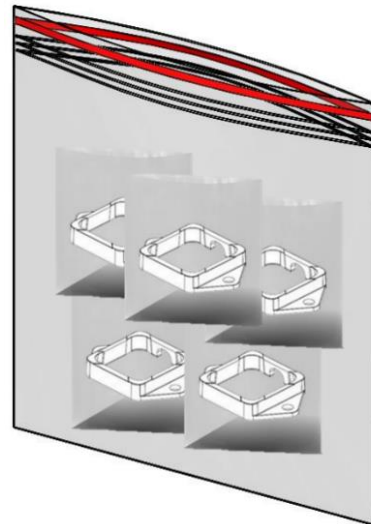

240 pcs/ per carton
Dimensions – 370x370x300 mm
Weight – 5.5 Kg

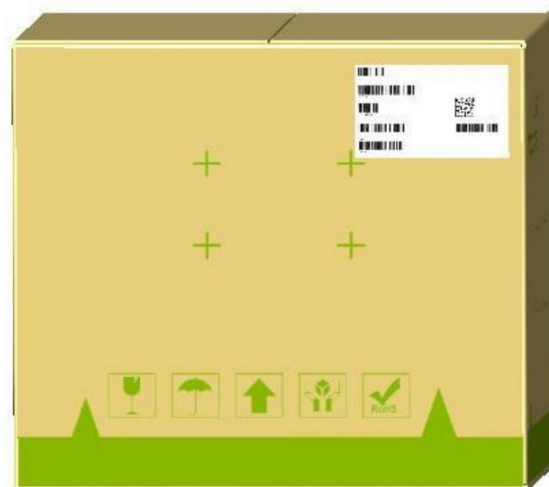

Changelog for the datasheet

SPE-23-8-270– MB.A.MX2

Revision: A (Initial Release)

| | |
|------------------|-----------------|
| Date: | 2023-09-14 |
| Changes: | Initial Release |
| Changes Made by: | Cesar Sousa |

Previous Revisions

| | |
|--|--|
| | |
| | |
| | |
| | |
| | |



www.taoglas.com

