



TAOGLAS®



Datasheet

Part No:
PCS.25.A

Description

Wi-Fi / Bluetooth 2.4GHz FR4 Chip Antenna

Features:

2.4GHz FR4 Chip Antenna
Dimensions: 15x3x3mm
FR4 material SMD Antenna
RoHS & Reach Compliant

1.	Introduction	2
2.	Specifications	3
3.	Antenna Characteristics	4
4.	Radiation Patterns	6
5.	Mechanical Drawing	9
6.	Antenna Integration Guide	10
7.	Packaging	18
<hr/>		
	Changelog	20

Taoglas makes no warranties based on the accuracy or completeness of the contents of this document and reserves the right to make changes to specifications and product descriptions at any time without notice. Taoglas reserves all rights to this document and the information contained herein. Reproduction, use or disclosure to third parties without express permission is strictly prohibited.



1. Introduction



The Taoglas PCS.25.A has been expertly designed as a 2.4GHz antenna for various Bluetooth and Wi-Fi applications. The PCS.25 is an FR4 antenna designed to be mounted via SMD on a PCB. The PCS.25 has been designed to operate both with and without clearance, meaning it can be used on boards where space is at a premium.

Typical Applications Include:

- Wearables
- Keyless Entry
- Handheld Devices
- Smart Healthcare

The PCS.25.A has been designed in a compact form factor of just 15x3x3mm, allowing it to be used in areas where other antennas that require large keep out areas, several matching components and vast ground planes to operate are currently used.

Patch antennas can be specifically tuned to customer-specific device environments, subject to NRE and MOQ. Contact your regional Taoglas customer support team to request these services or additional support to integrate and test this antenna's performance in your device.

2. Specifications

Electrical	
Frequency (MHz)	2400-2500MHz
Efficiency (%)	
With Clearance	52
Without Clearance	31
Average Gain (dB)	
With Clearance	-2.9
Without Clearance	-5.1
Peak Gain (dBi)	
With Clearance	2
Without Clearance	0.1
Impedance	50 Ω
Polarization	Linear
Radiation Pattern	Omni
Max. input power	10W
*Tested on 50x50 mm ground plane	

Mechanical	
Dimensions	15*3*3mm
Weight	2g
Material	FR4
Environmental	
Temperature Range	-40°C to 85°C
Humidity	Non-condensing 65°C 95% RH

3. Antenna Characteristics

3.1 Return Loss

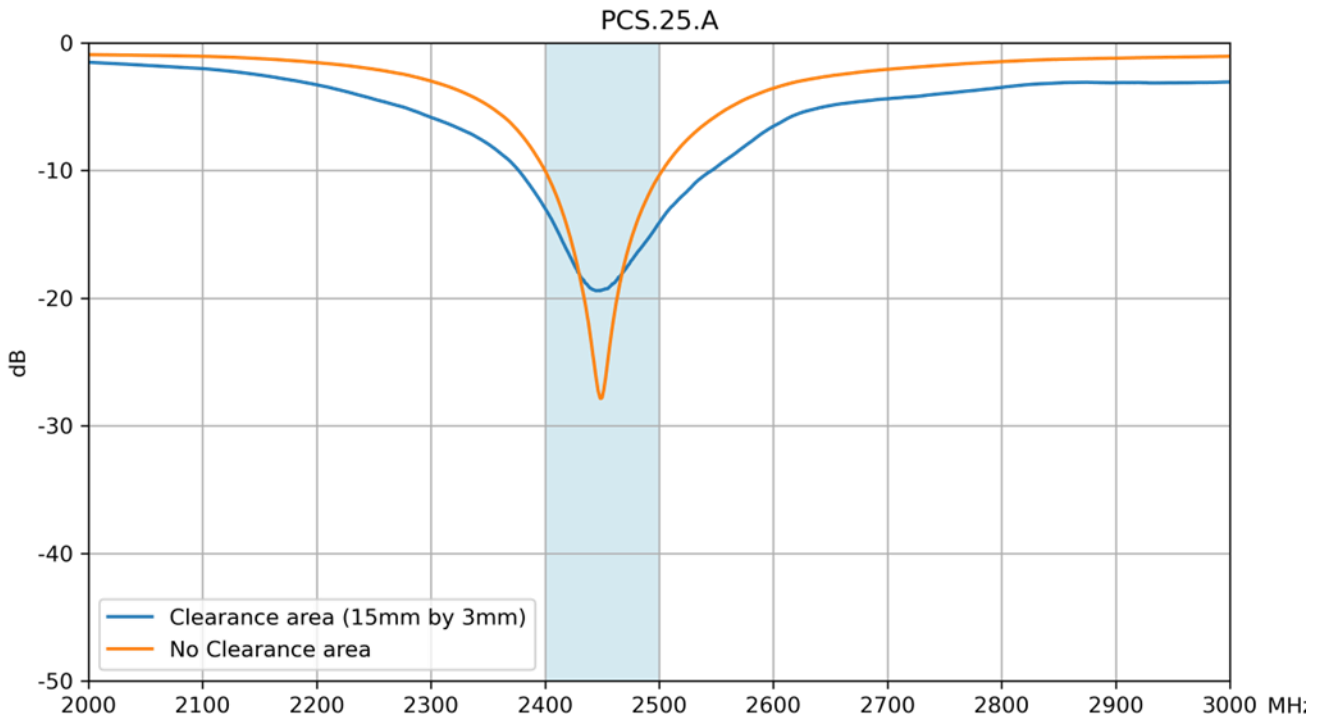

3.2 Efficiency

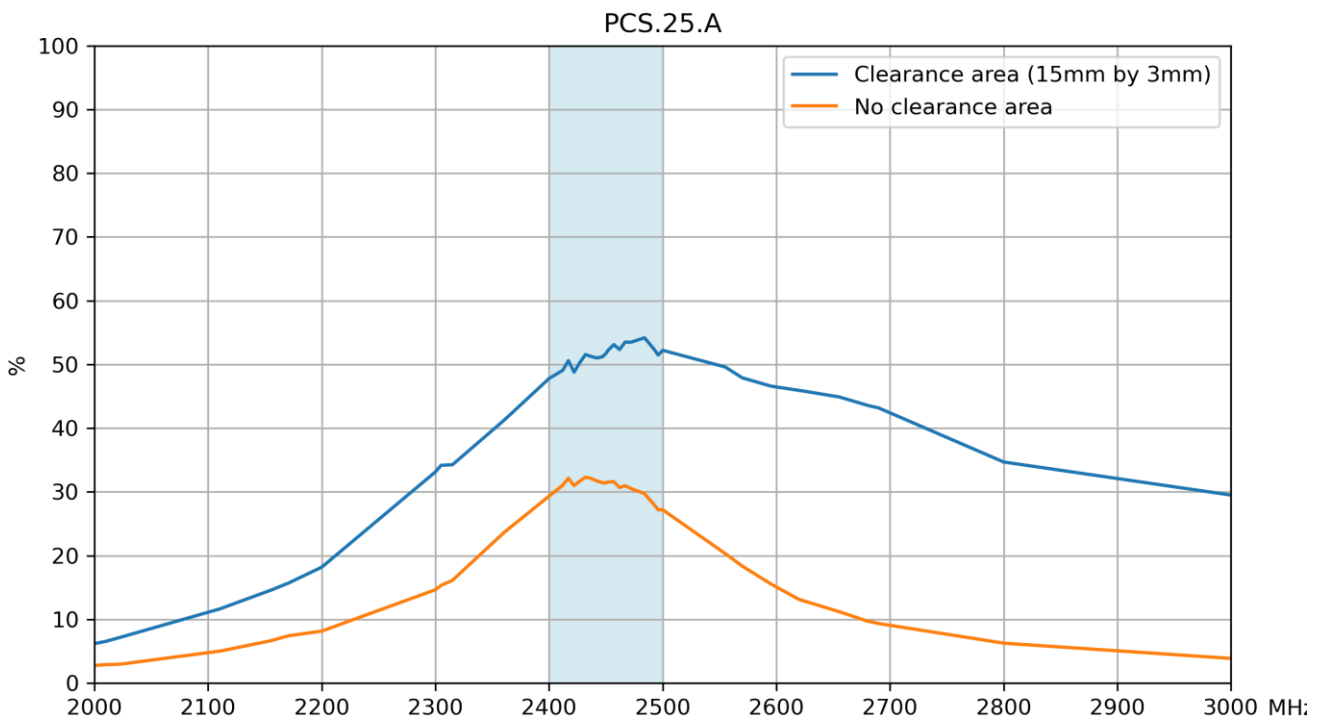

3.3 Average Gain

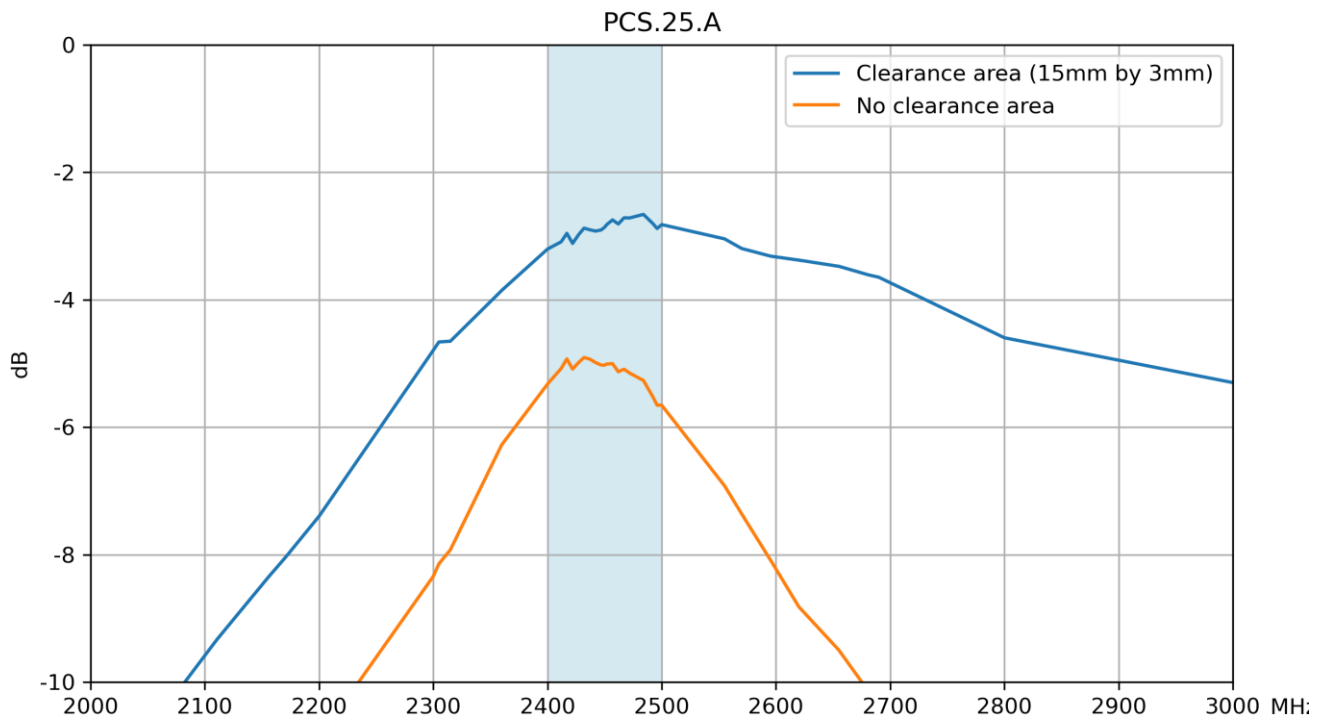

3.4 Peak Gain

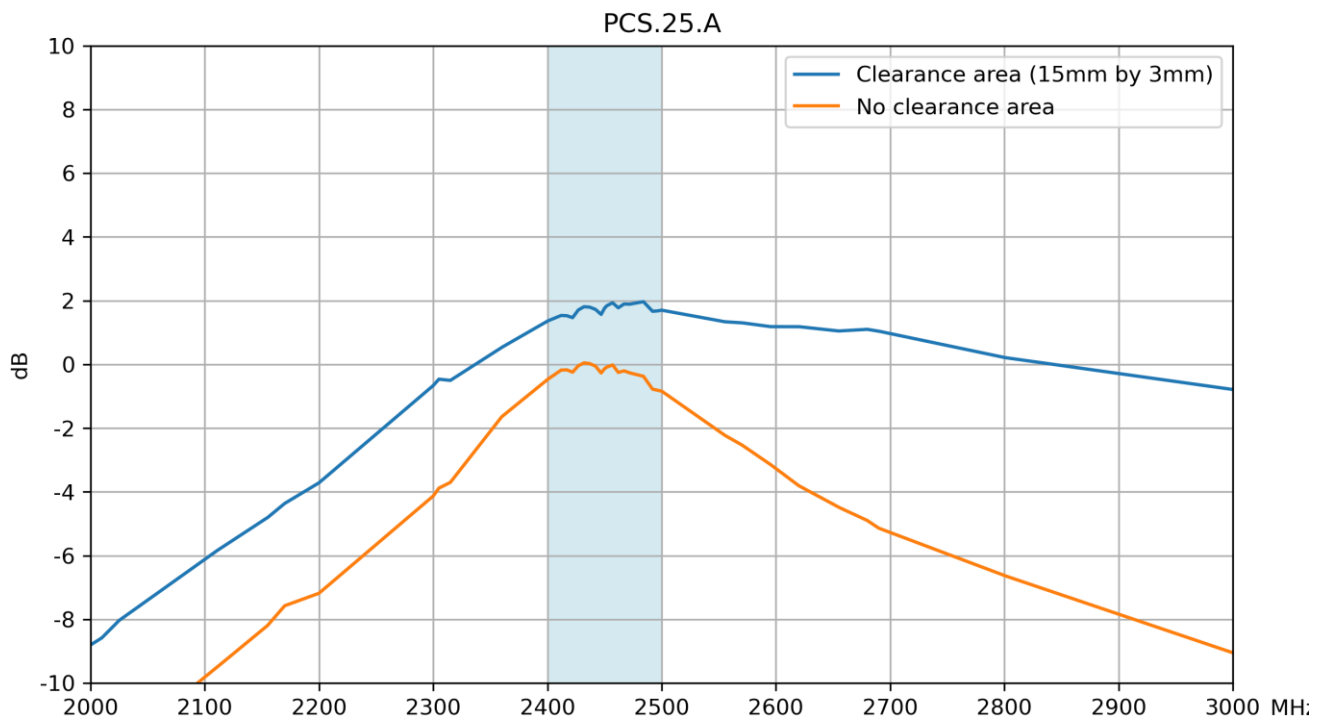

4. Radiation Patterns

4.1 Test Setup

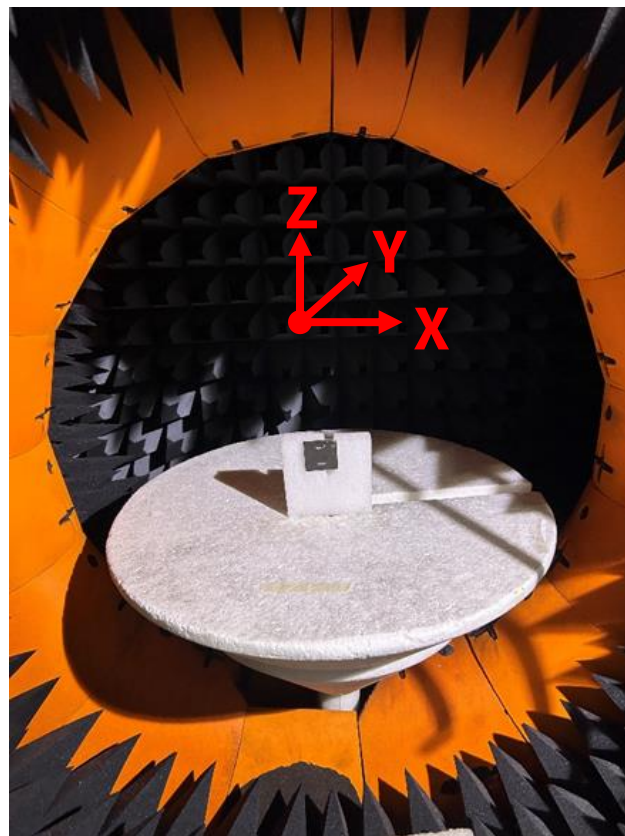
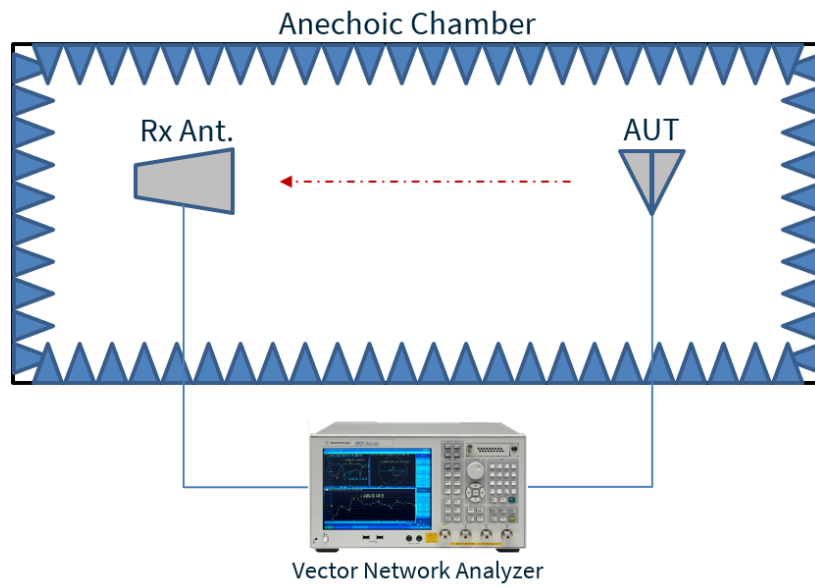

4.2 3D and 2D Radiation Patterns with clearance at 2450MHz

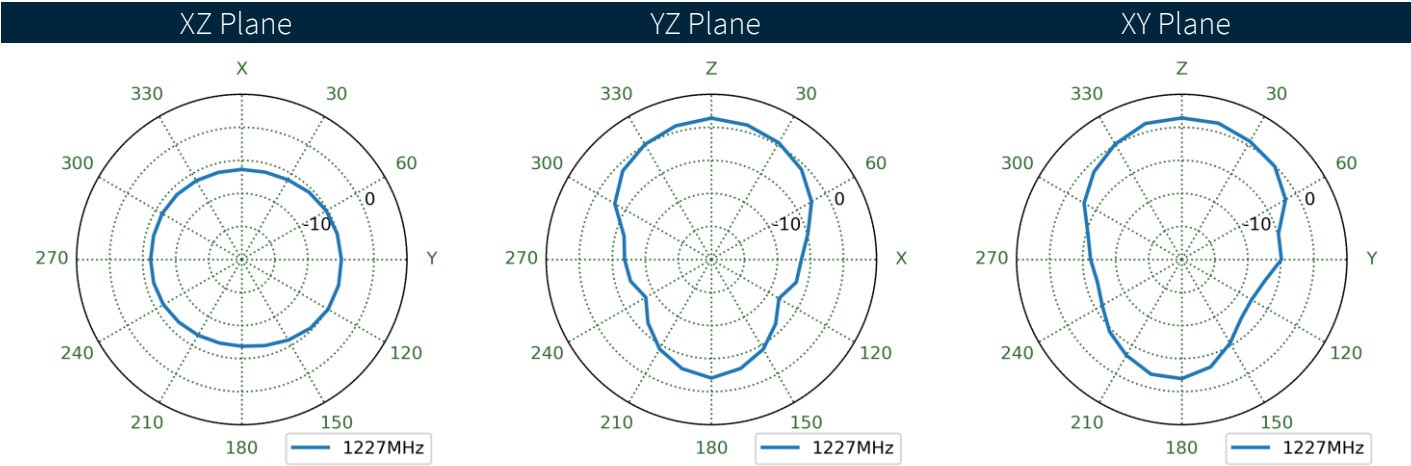
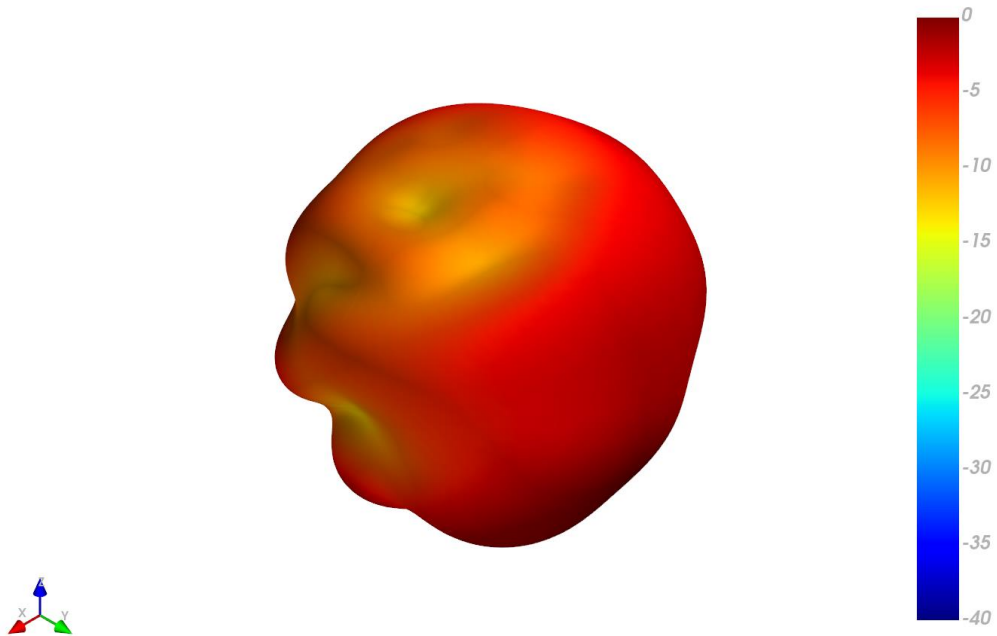

4.3 3D and 2D Radiation Patterns with no clearance at 2450MHz

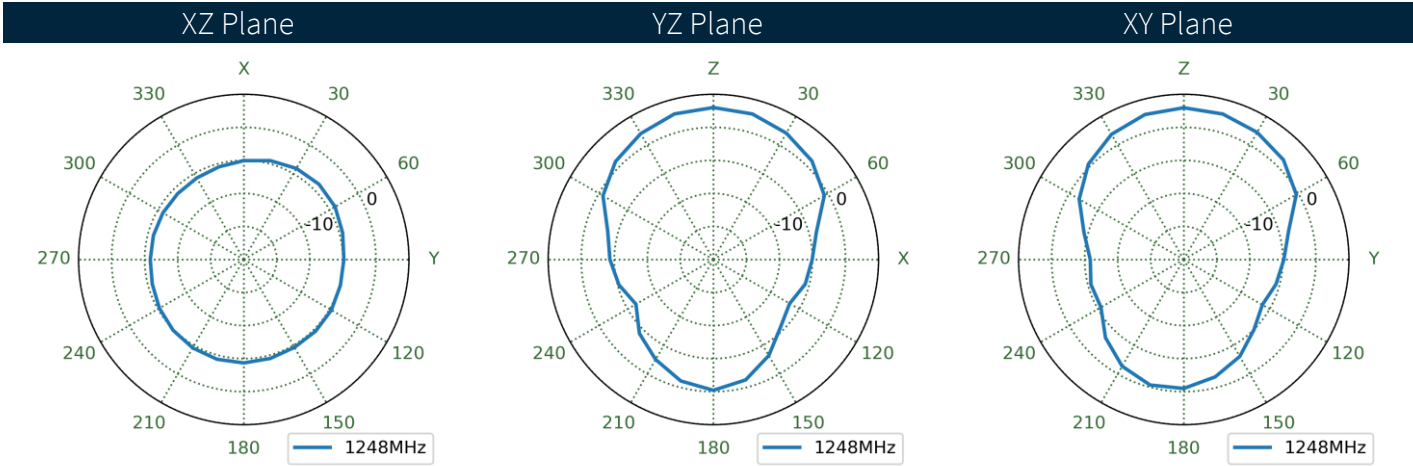
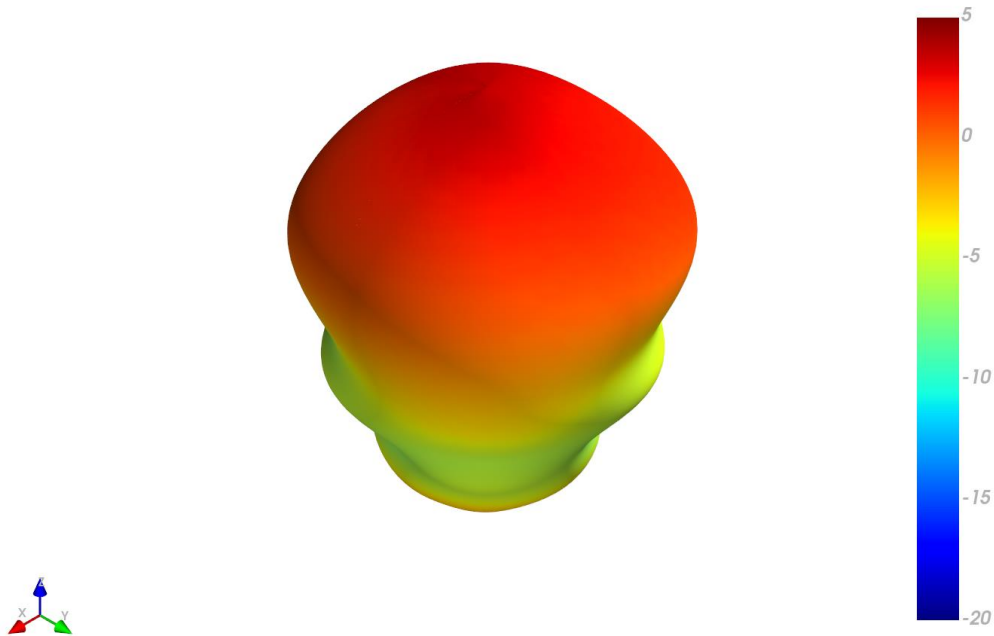

5. Mechanical Drawing

6. Antenna Integration Guide



6.1 Schematic Symbol and Pin Definitions

The circuit symbol for the antenna is shown below. The antenna has 3 pins with all three pins as functional.

Pin	Description
1	RF Feed
2, 3	Ground

TAOGLAS_PCS.25.A ANT1

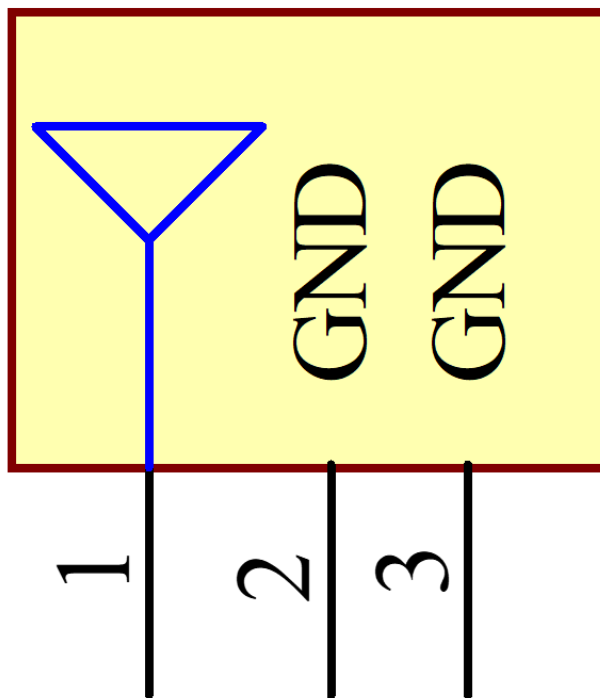

6.2 Antenna Integration

For any given PCB size, the antenna should ideally be placed on the PCB's corner edge, to take advantage of the ground plane. Optimized matching components can be placed as shown.

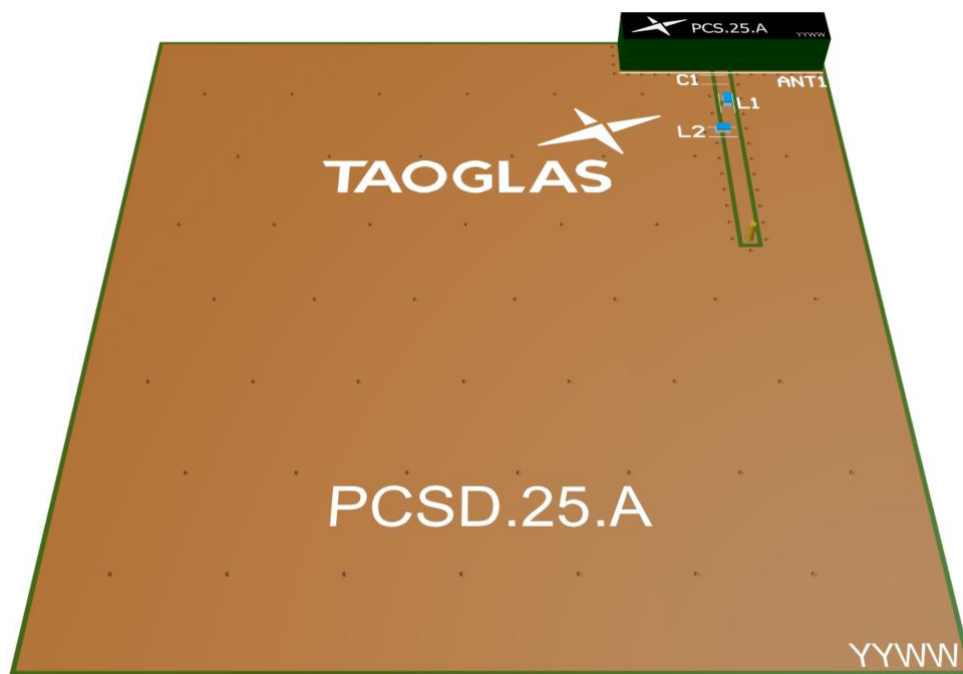

6.3 PCB Layout

The footprint and clearance on the PCB must meet the layout drawing in section (Footprint Drawing). Note the placement of the optimized components. L1 is placed as close as possible to the RF feed (pad 1) within the copper keep out area. L2 is then placed tightly in parallel after that. C1 is an optional component but the footprint is recommended in case it is needed.

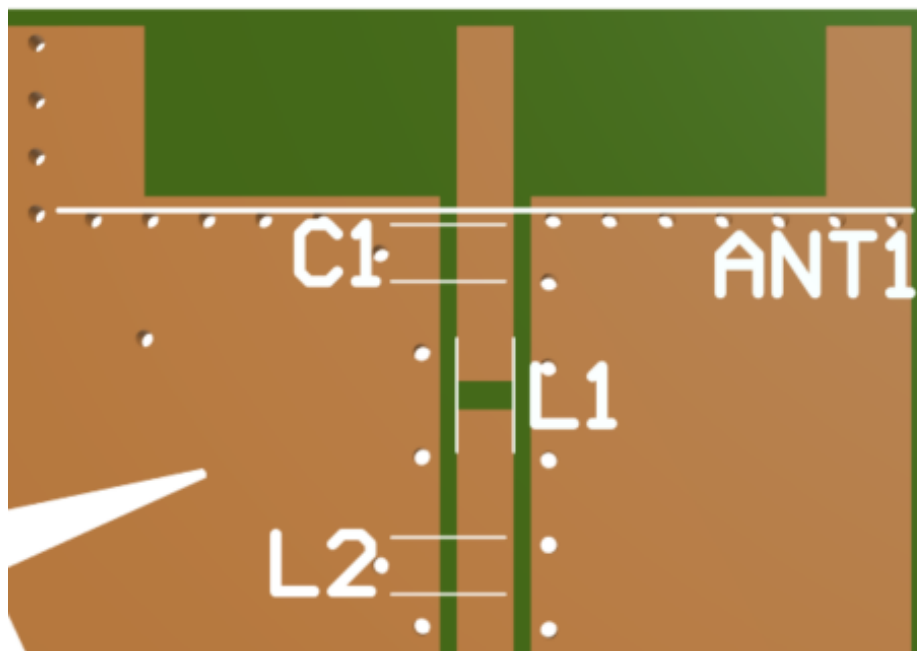

Without Antenna

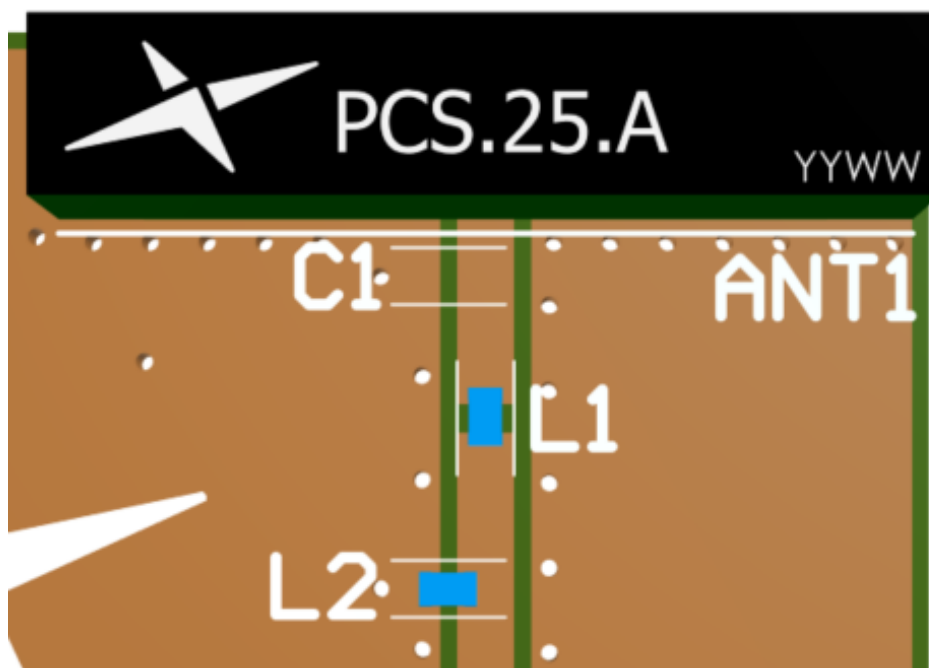

With Antenna

6.4 PCB Clearance

Below shows the antenna footprint and clearance through ALL layers on the PCB. Only the antenna pads and connections to feed and GND are present within this clearance area (marked RED). The clearance area extends to 15.3mm in width and 3.3mm in length from the corner the PCB. This clearance area includes the bottom side and ALL internal layers on the PCB other than the top layer. The clearance area for the top side extends to 12mm in width and 3.3mm in length, 1.8mm in from the edge of the PCB.

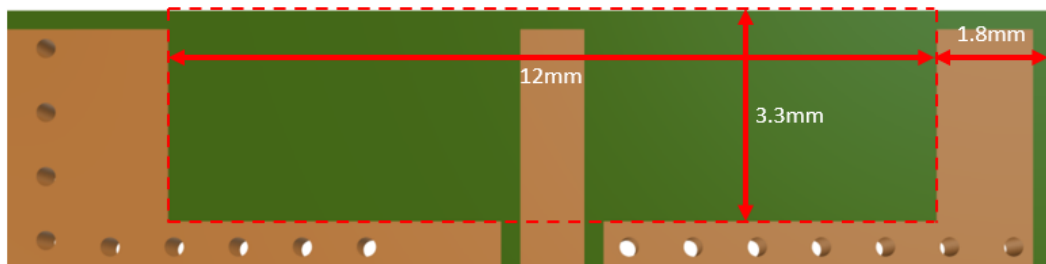

Topside

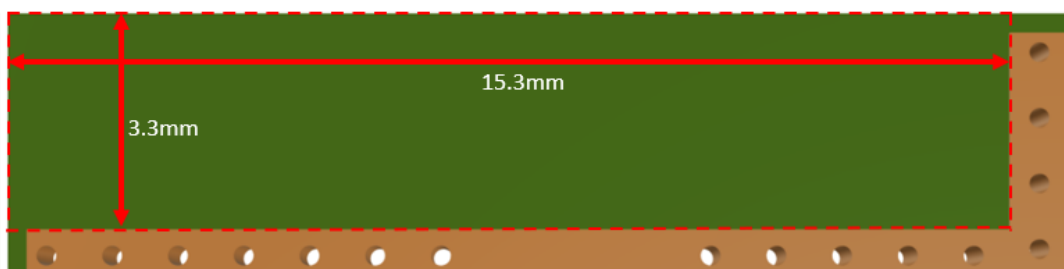

Bottom side

6.5 Evaluation Board

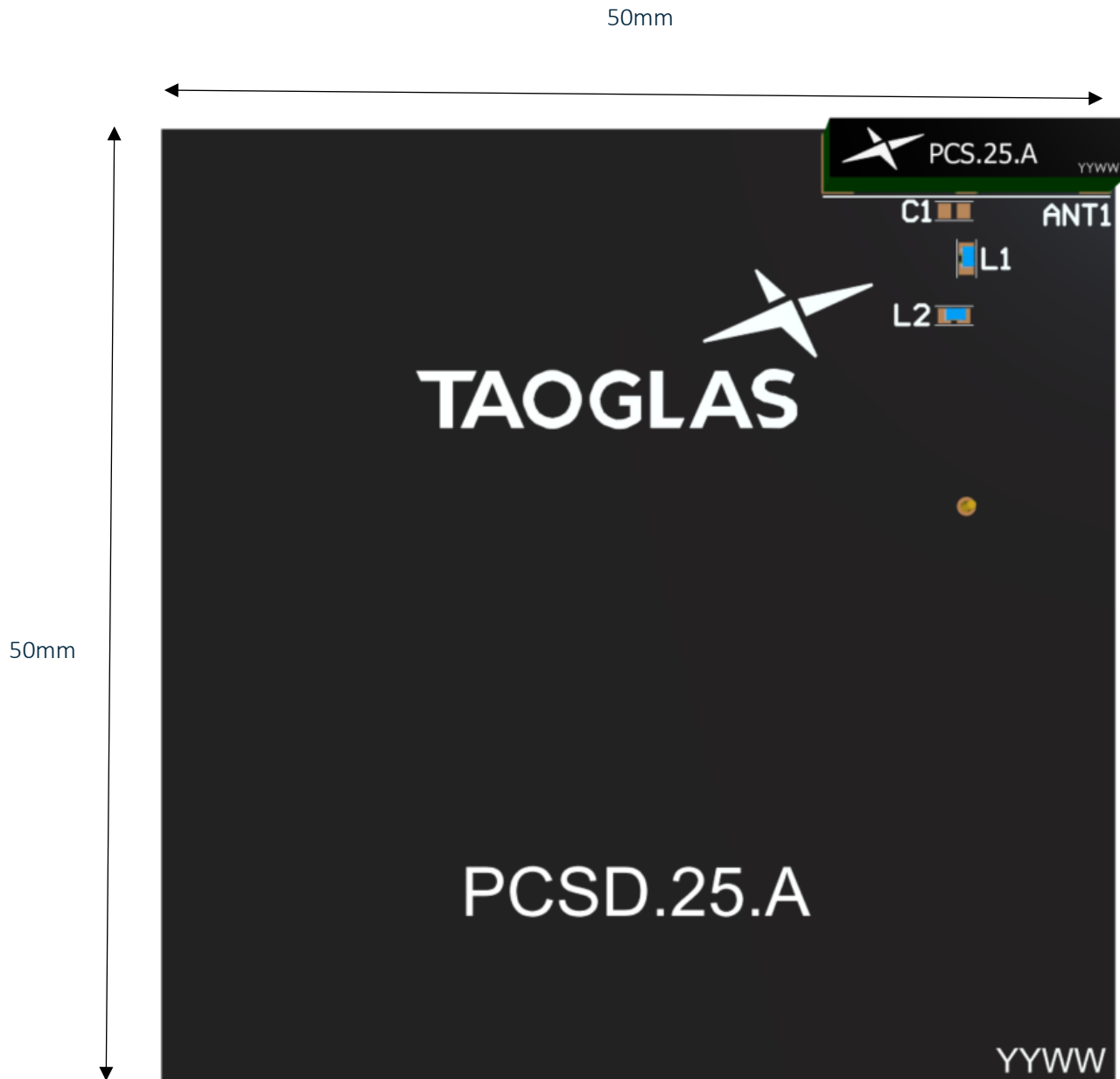

6.6 Matching Circuit

Matching components with the PCS.25.A are recommended for the antenna to have optimal performance on the evaluation board, located in the spaces specified in the above images. Additional matching components may be necessary for your device, so we recommend incorporating extra component footprints, forming a “pi” network, between the cellular module and the edge of the ground plane.

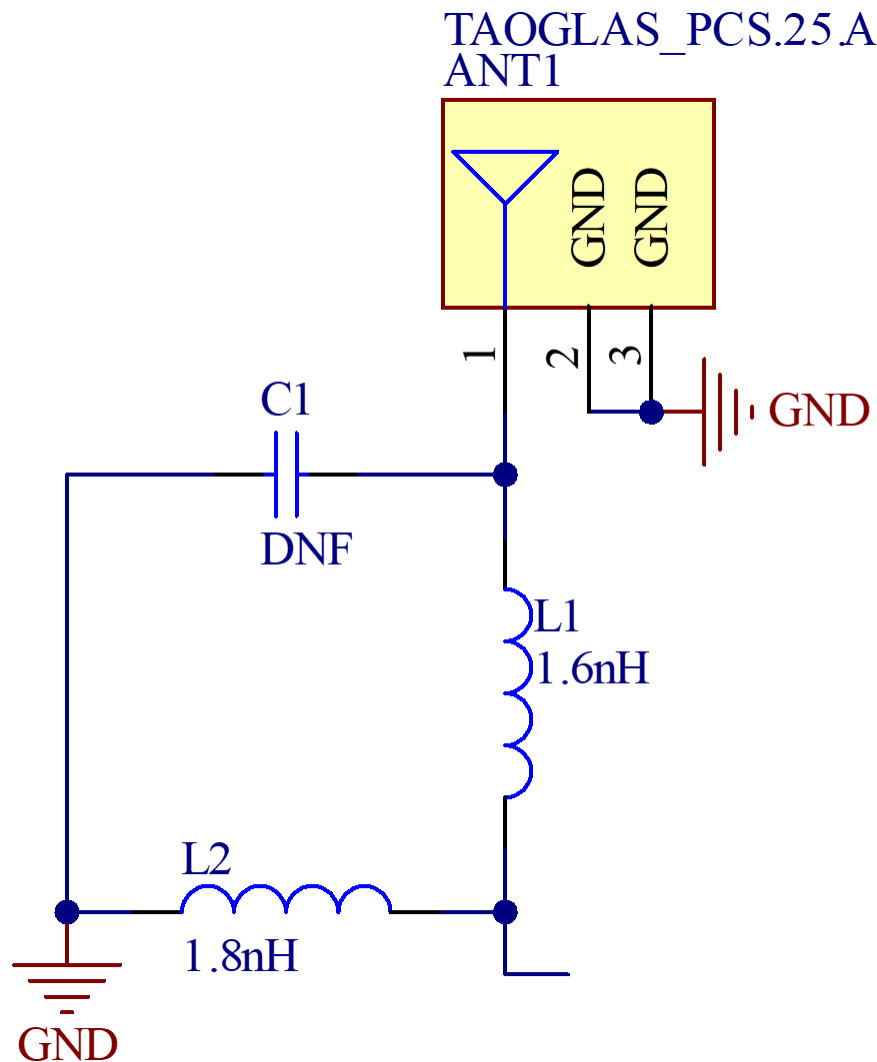

Designator	Type	Value	Manufacturer	Manufacturer Part Number
C1	Capacitor	Not Fitted	-	-
L1	Inductor	1.6nH	Murata	LQW15AN1N6C00D
L2	Inductor	1.8nH	Murata	LQW15AN1N8C00D

6.7 Footprint

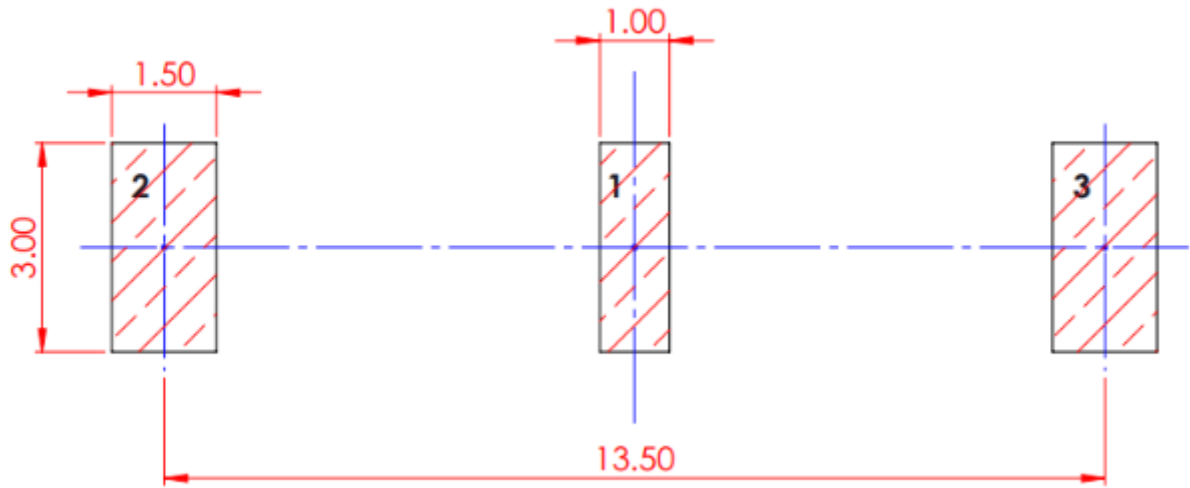

6.8 Top Solder Paste

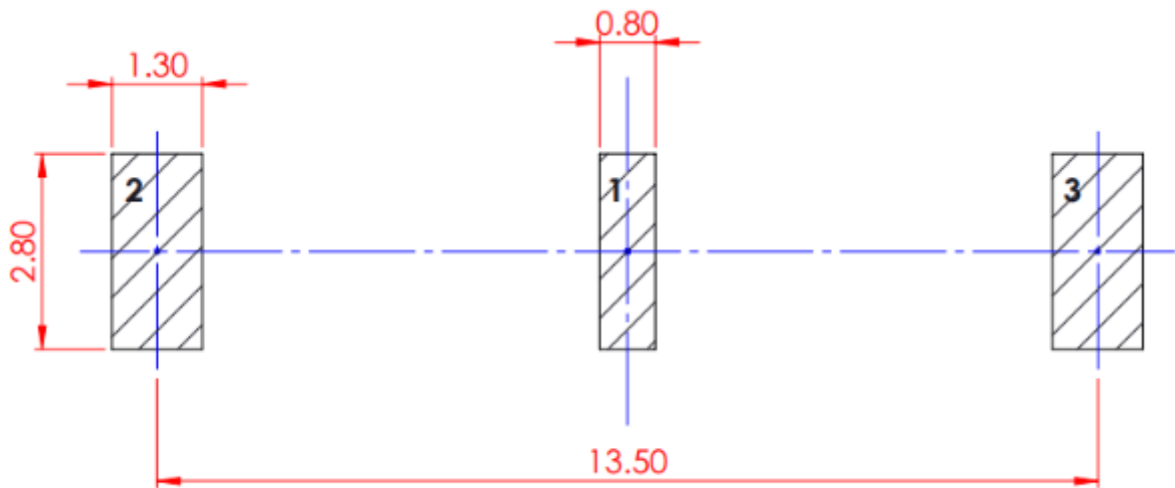

7. Packaging

2000pcs PCS.25.A per Reel

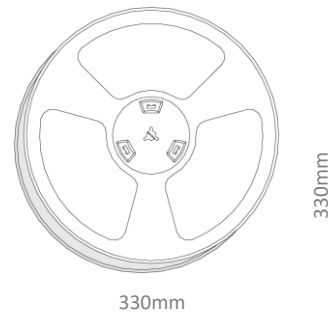

2000pcs PCS.25.A per Inner Carton
Dimensions: 350*350*70 mm

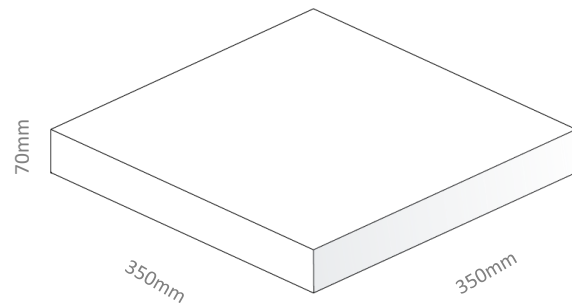

6000pcs PCS.25.A per Inner Carton Dimensions:
370*360*275 mm

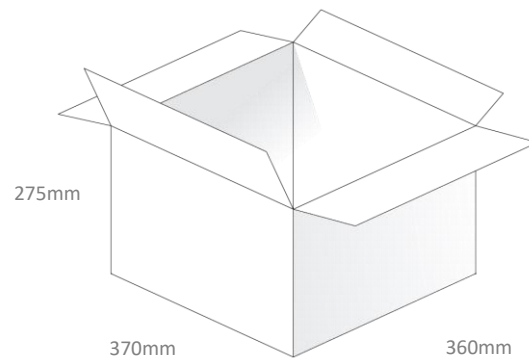

Changelog for the datasheet

SPE-23-8-283– PCS.25.A

Revision: A (Original First Release)

Date:	2023-09-12
Notes:	Initial Release
Author:	Cesar Sousa

Previous Revisions



www.taoglas.com

