



TAOGLAS®



Datasheet

Part No:
PCS.27.A

Description

Wi-Fi® 2.4/5.8/7.125GHz FR4 PIFA SMD Antenna

Features:

Low-profile SMD Antenna
Wi-Fi® 6 Coverage - 2.4GHz / 5.8GHz / 7.125 GHz
Dims: 12mm x 5mm x 3.1mm
RoHS & Reach Compliant

1.	Introduction	3
2.	Specification	4
3.	Mechanical Drawing	5
4.	Antenna Integration Guide	6
5.	Packaging	14
6.	Solder Reflow Profile	15
7.	Antenna Characteristics	16
8.	Radiation Patterns	20
<hr/>		
	Changelog	24

Taoglas makes no warranties based on the accuracy or completeness of the contents of this document and reserves the right to make changes to specifications and product descriptions at any time without notice. Taoglas reserves all rights to this document and the information contained herein. Reproduction, use or disclosure to third parties without express permission is strictly prohibited.

Ireland & USA
ISO 9001:2015
Certified



Taiwan
ISO 9001:2015
Certified



046



IATF16949



1. Introduction

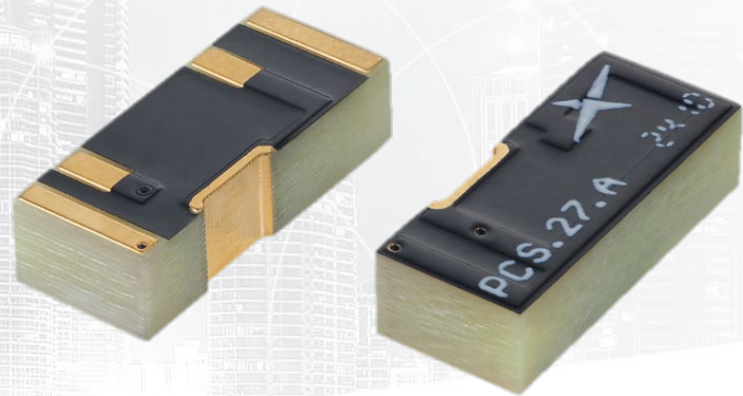

Super Small, Antenna Designed for High-performance Wi-Fi® 6/7 Applications

The Taoglas PCS.27.A is an expertly designed Wi-Fi® antenna for various Bluetooth and Wi-Fi® applications. Engineered to cover 2.4, 5.8 and 7.125GHz bands, the antenna is suitable for Wi-Fi® 6/7 applications allowing you to future proof your device design. The high-performance FR4 antenna, supplied on tape and reel, is designed to be mounted via SMD on a PCB. It is engineered to operate both with, and without copper clearance on all PCB layers, meaning it can be used on boards where space is at a premium.

The PCS.27.A has a compact form factor of just 12.0 x 5.0 x 3.1mm and requires a small keep out area of allowing it to be used where other antennas cannot. Many competitor products require large keep out areas and several matching components on much larger ground planes to operate.

Typical applications that the PCS.27.A is suitable for include:

- Wearables and Handheld Wi-Fi® devices
- Smart Home and Office Automation
- Entertainment Systems with 4K / 8K Streaming, VR and AR
- Keyless entry systems and Access Control Systems
- Smart Telemedicine and Healthcare
- Industrial Automation and Predictive Maintenance Systems

Taoglas high-performance FR4 antennas can be specifically tuned to customer-specific device environments, subject to NRE and MOQ. Contact your regional Taoglas customer support team to request these services or additional support to integrate and test this antenna's performance in your device.

2. Specification

Wi-Fi Electrical								
Band	Frequency (MHz)	Efficiency (%)	Average Gain (dB)	Peak Gain (dBi)	Impedance	Polarization	Radiation Pattern	Max. input power
Wi-Fi - 2GHz	2400-2500	39.0	-4.09	1.19	50 Ω	Linear	Omni	2W
Wi-Fi - 5GHz	5150-5850	55.8	-2.54	3.53				
Wi-Fi - 6GHz	5925-7125	48.8	-3.12	3.94				

Mechanical	
Dimensions	12.0 x 5.0 x 3.1mm
Weight	1g
Material	FR4
Mounting	SMT

Environmental	
Temperature Range	-40°C ~ +85°C
Moisture Sensitivity	3
RoHs & REACH Compliant	Yes

3. Mechanical Drawing

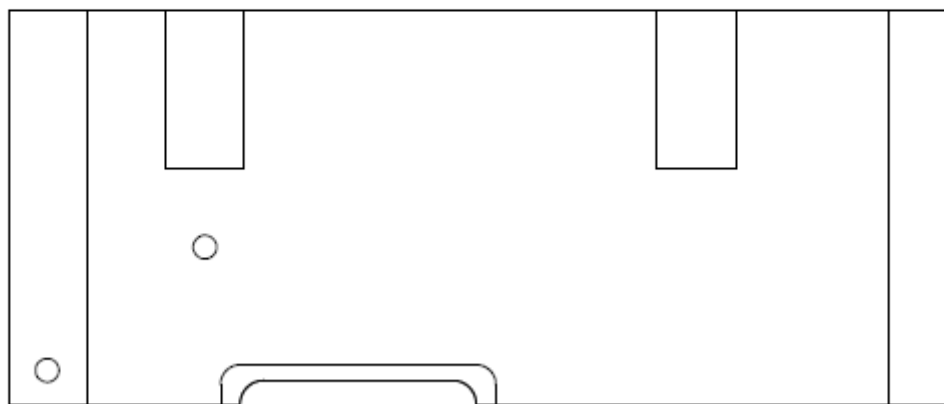
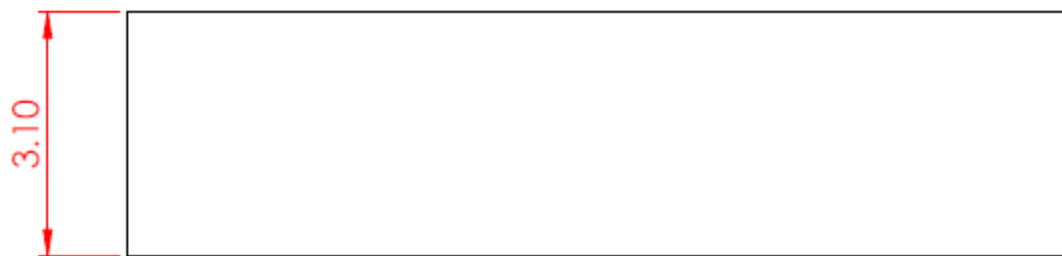
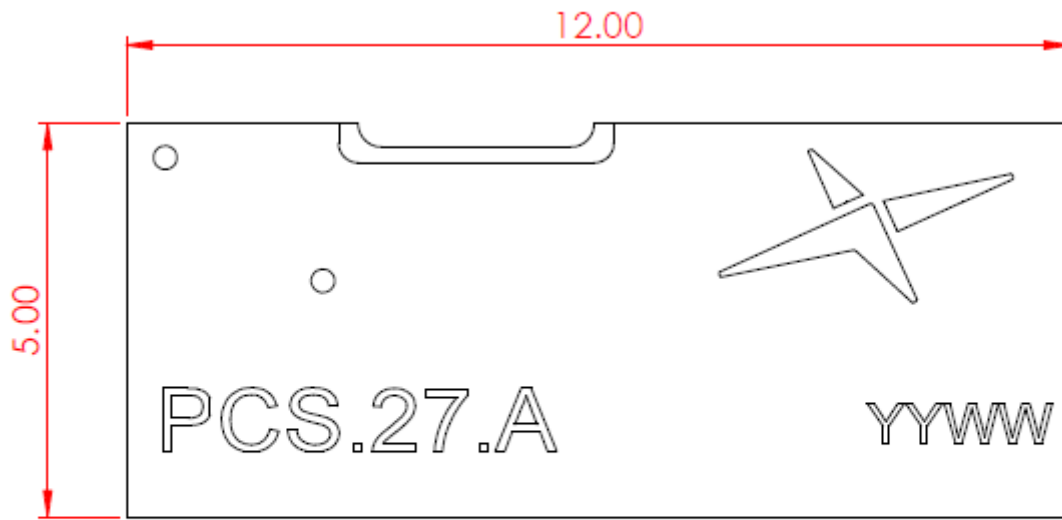

4. Antenna Integration Guide

The following is an example on how to integrate the PCS.27.A into a design. This antenna has 4 pins, where one pin is used for the RF Feed. Taoglas recommends using a minimum of 50x50mm ground plane (PCB) to ensure optimal performance.

The antenna should be placed on the corner of the PCB to take advantage of the ground plane on the side of the antenna.

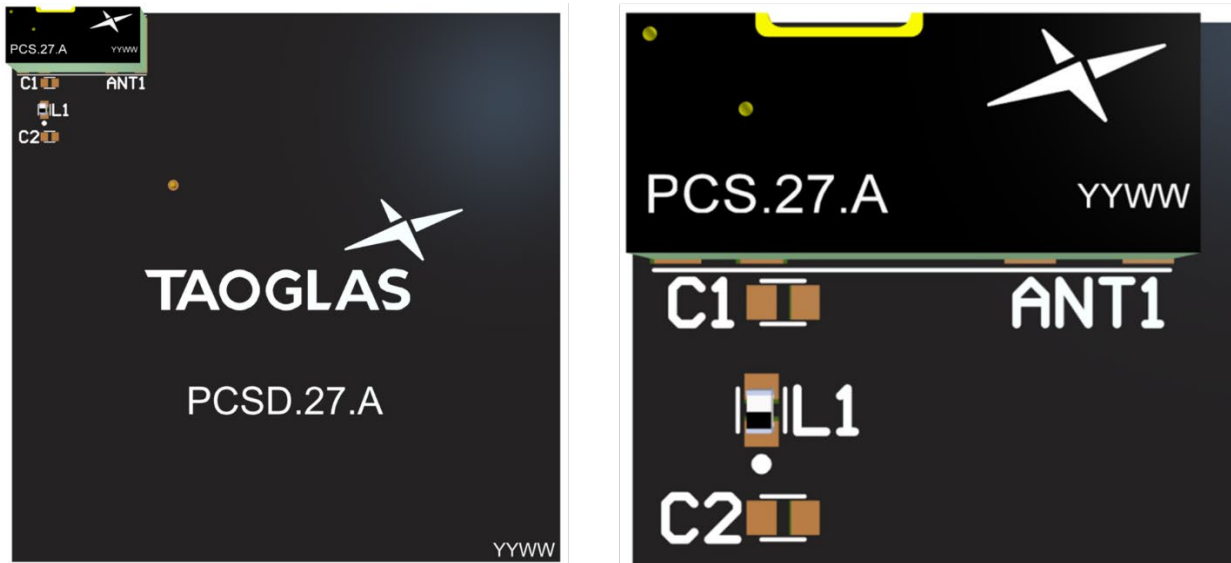

Top view of PCB.

Please find the Integration files in Altium and the 3D model for the PCS.27.A here:
<https://www.taoglas.com/product/pcs-27-a-super-small-wi-fi-6-7-smd-antenna/>

4.1 Schematic Symbol and Pin Definitions



Above is a 3D model of the PCS.27.A on a PCB.

The circuit symbol for the PCS.27.A is shown below. The antenna has 4 pins as indicated below.

Pin	Description
1	RF Feed
2, 3, 4	Ground

TAOGLAS_PCS.27.A
ANT1

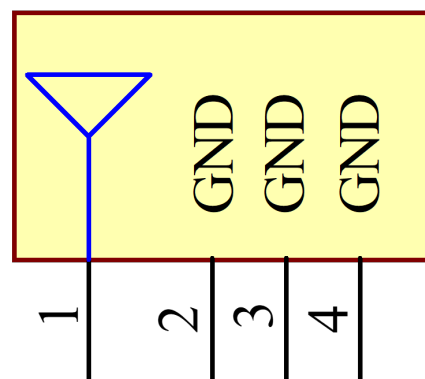

4.2 Antenna Footprint

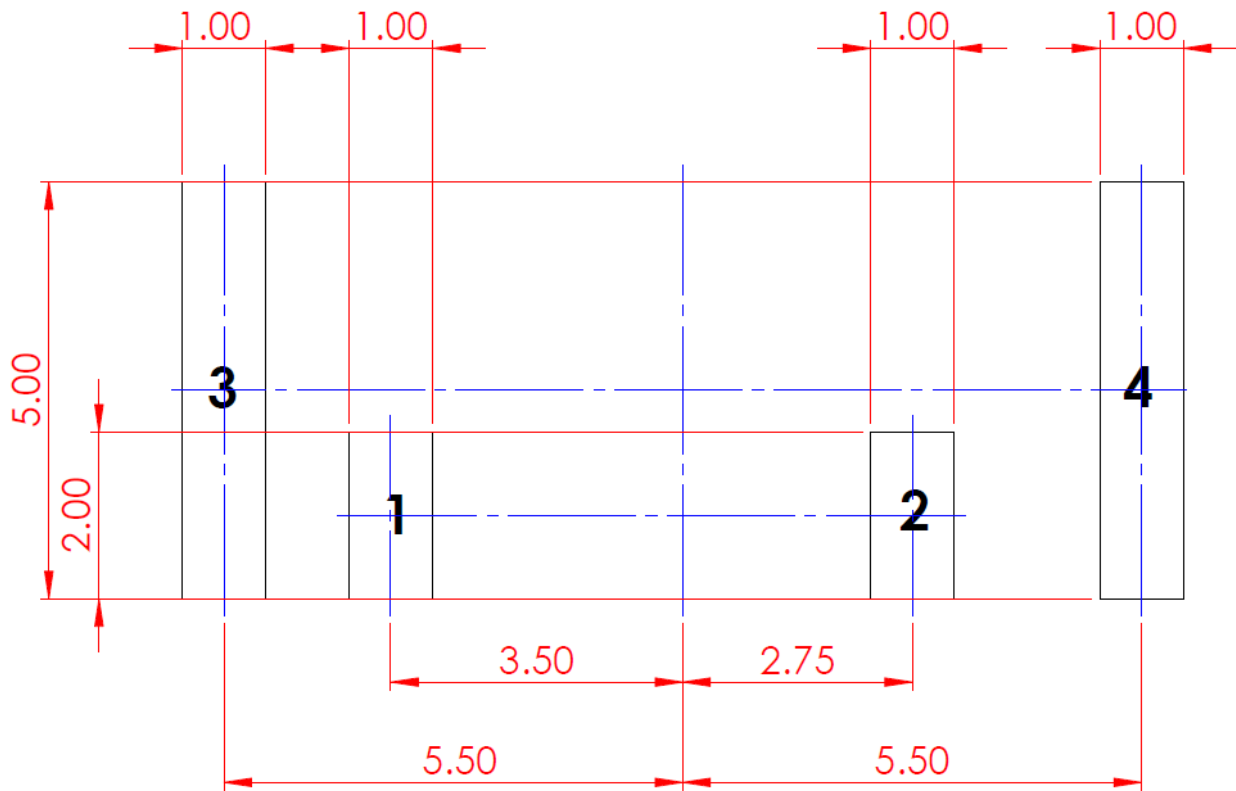

*Please note Top Solder Paste has the same dimensions as the Antenna Footprint

4.3 Copper Clearance for PCS.27.A

The footprint and clearance on the PCB must comply with the antenna's specification. The PCB layout shown in the diagrams below demonstrates the GLA.01 clearance area. The copper keep out areas apply to different layers on the PCB.

The top copper clearance area extends to 5mm in length and 11mm in width around the antenna and only applies to the top layer. The bottom copper clearance area extends to 5mm in length and 6mm in width around the antenna and applies to all other layers. The PCB edge clearance should be a minimum of 0.1mm, example below is 0.5mm.

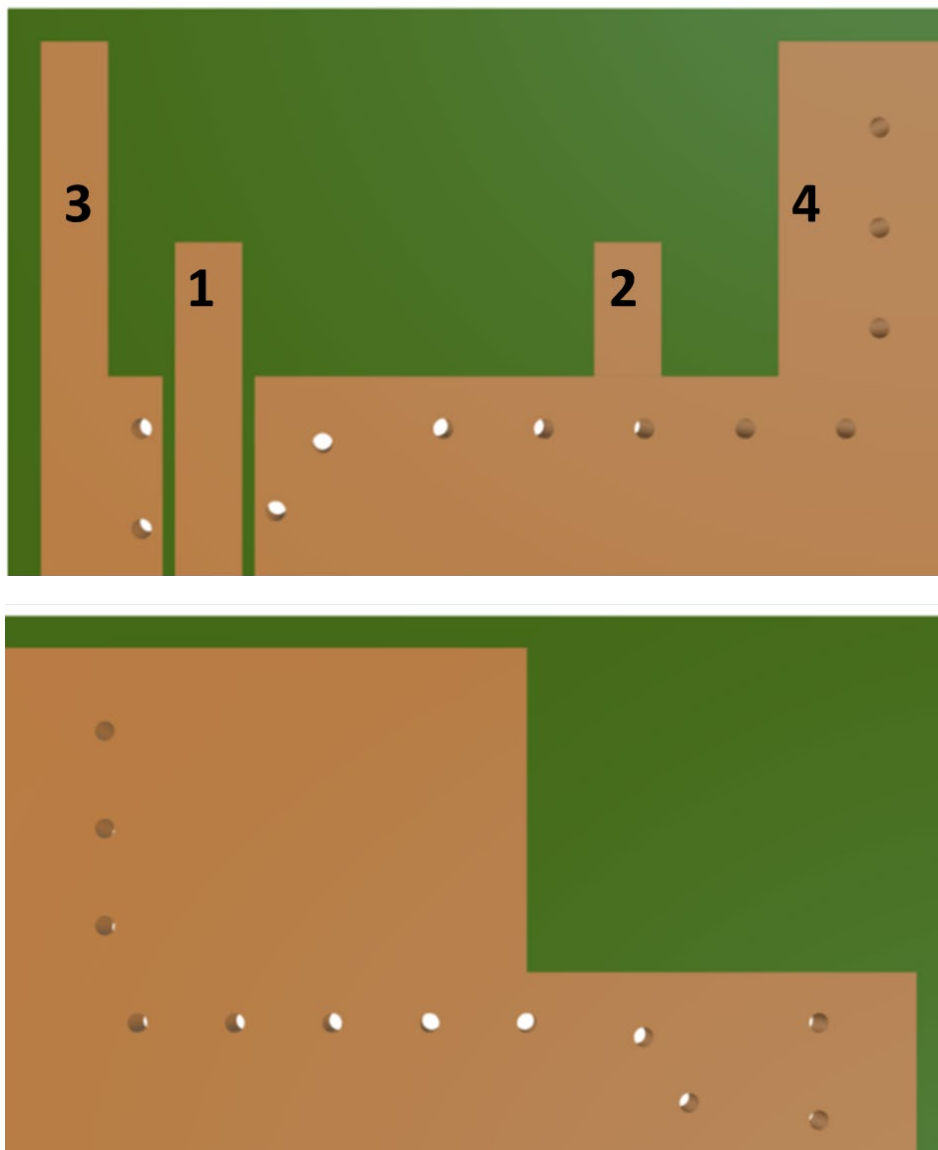

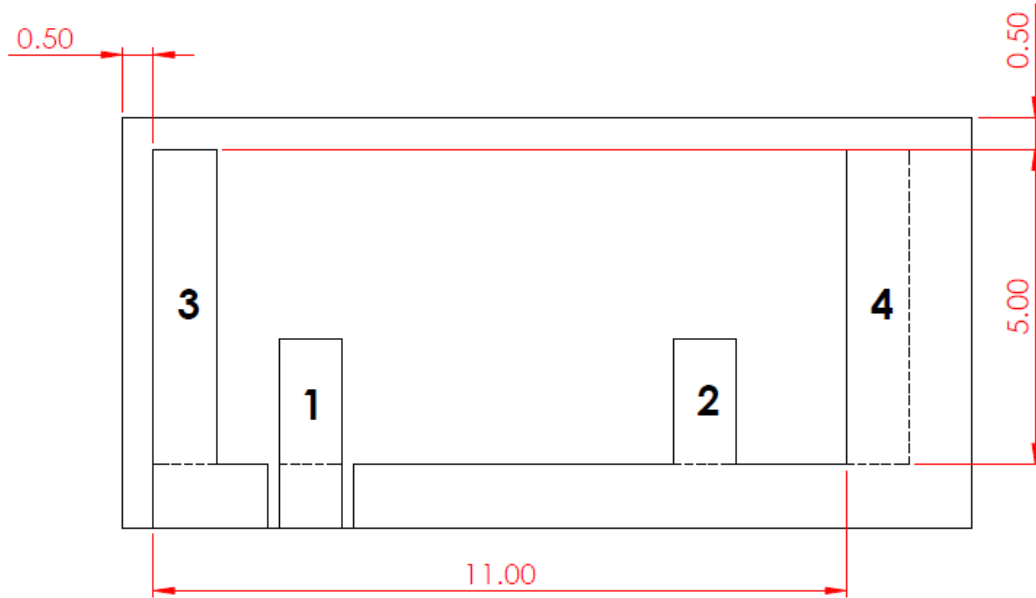

Copper Clearance Top Side

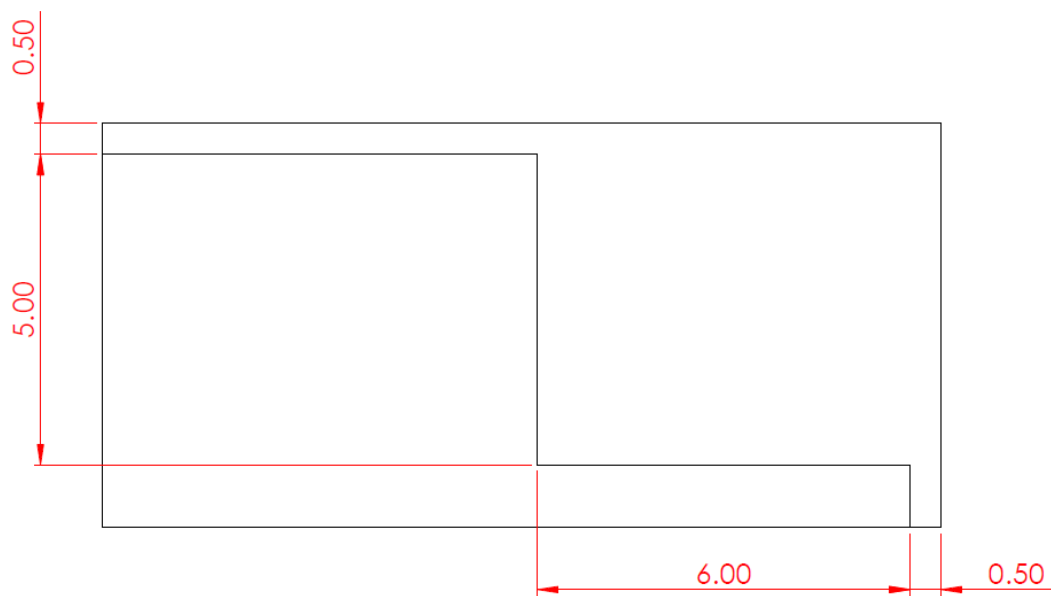

Copper Clearance Bottom Side

4.4 Schematic Layout

Matching components with the PCS.27.A are required for the antenna to have optimal performance in the spaces specified in the schematic below. Additional matching components may be necessary for your device, Taoglas recommends incorporating extra component footprints, forming a “pi” network, for the PCS.27.A.

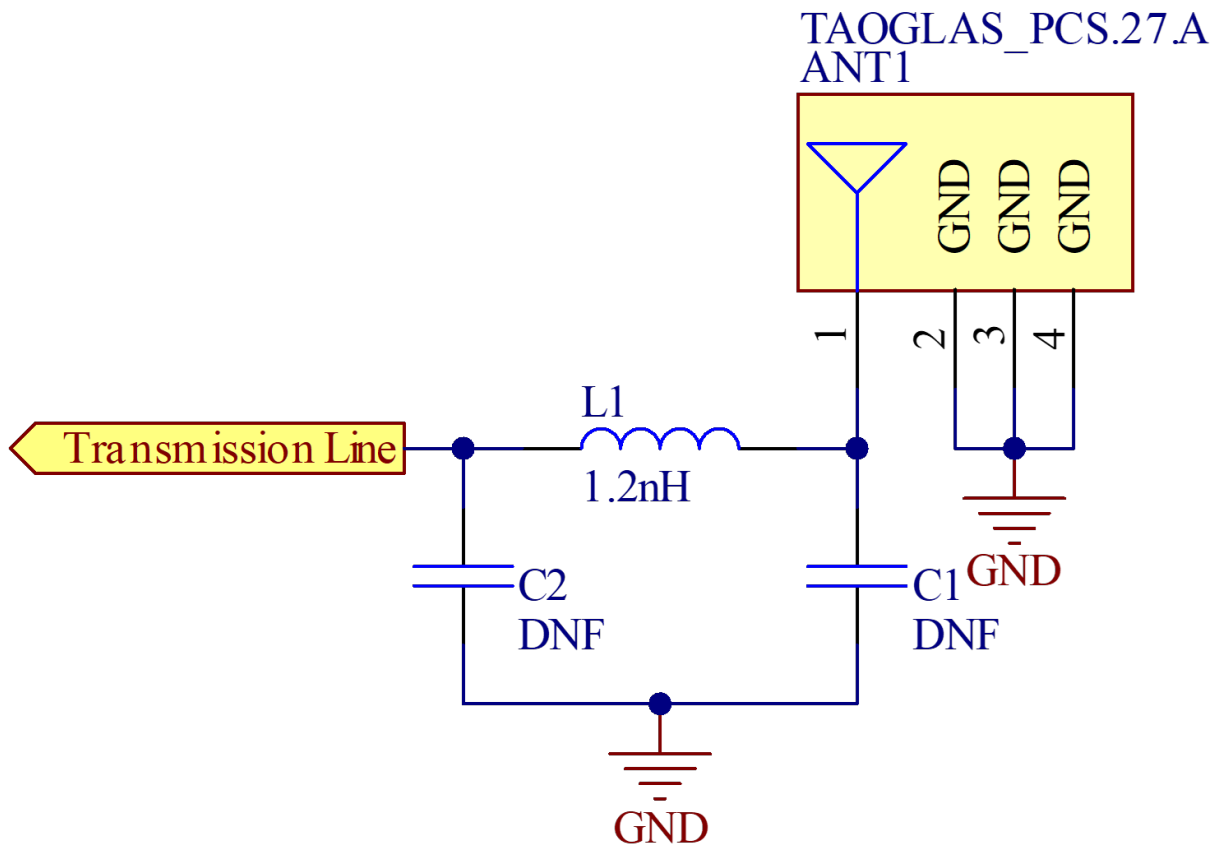

Designator	Type	Value	Manufacturer	Manufacturer Part Number
L1	Inductor	1.2nH	TDK	MHQ1005P1N2BT000

4.5 Antenna Integration

The PCS.27.A should be placed mid-point on the long side of the PCB to take advantage of the ground plane extending from each side of the antenna. The RF trace must maintain a 50 Ohm transmission line. A “Pi” Matching Network is recommended for the RF transmission line, the values and components for the matching circuit will depend on the tuning needed. Ground vias should be placed around the transmission line and the copper clearance area.

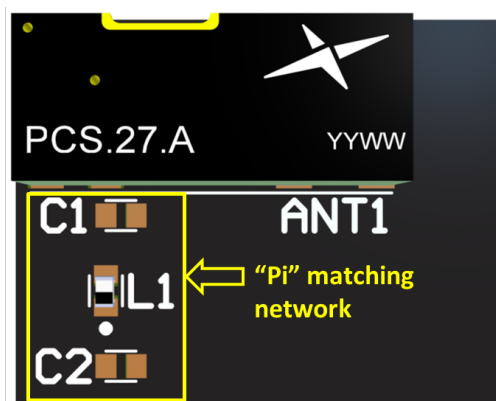

PCS.27.A antenna mounted on a PCB, showing “Pi” matching network.

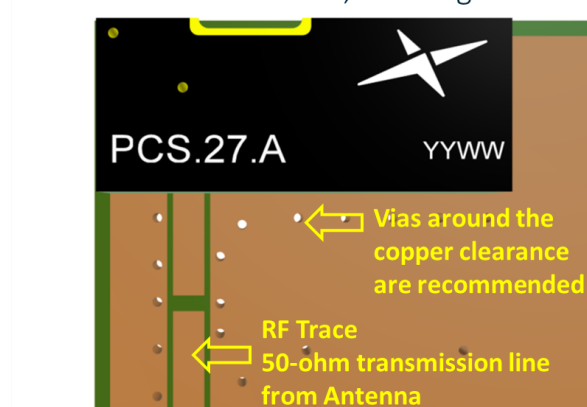

PCS.27.A antenna mounted on a PCB, showing transmission line and integration notes.

4.6 Final Integration

The top side image shown below highlights the antenna transmission line. Taoglas recommends using a minimum of 50x50mm ground plane (PCB) to ensure optimal performance.

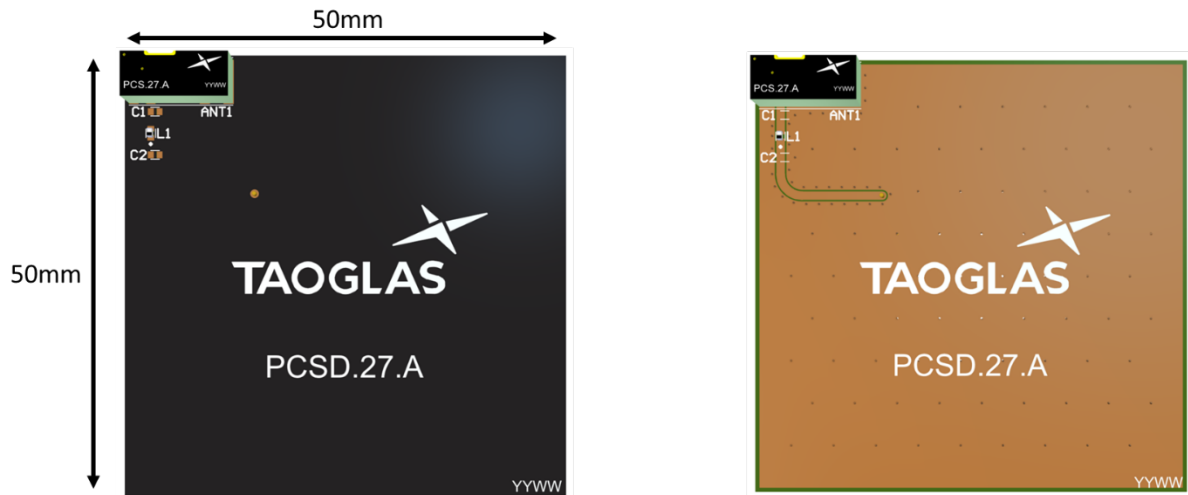

Top Side (PCS.27.A placement on 50x50mm PCB)

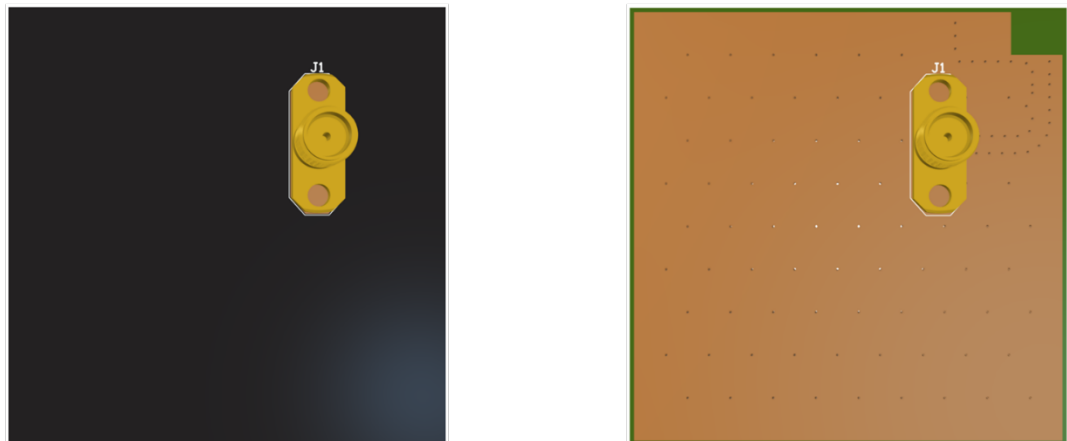

Bottom Side (50x50mm PCB)

5. Packaging

1400pcs PCS.27.A per tape and reel
 1 pcs humidity indicator card
 2 pcs desiccant



1400pcs PCS.27.A per vacuum bag



1400pcs PCS.27.A per small box
 Dimensions 335 x 335 x 64mm
 Weight – 1.19Kg



5600pcs PCS.27.A per carton
 Dimensions 370 x 370 x 300mm
 Weight – 5.48Kg

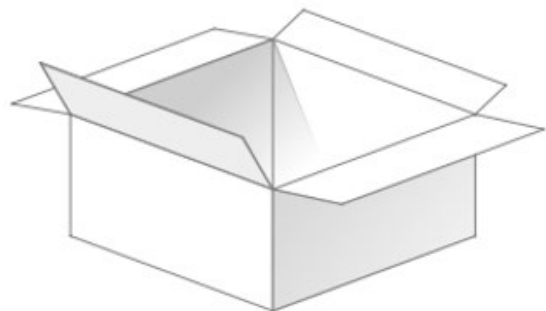

6. Solder Reflow Profile

The PCS.27.A can be assembled by following the recommended soldering temperatures are as follows:

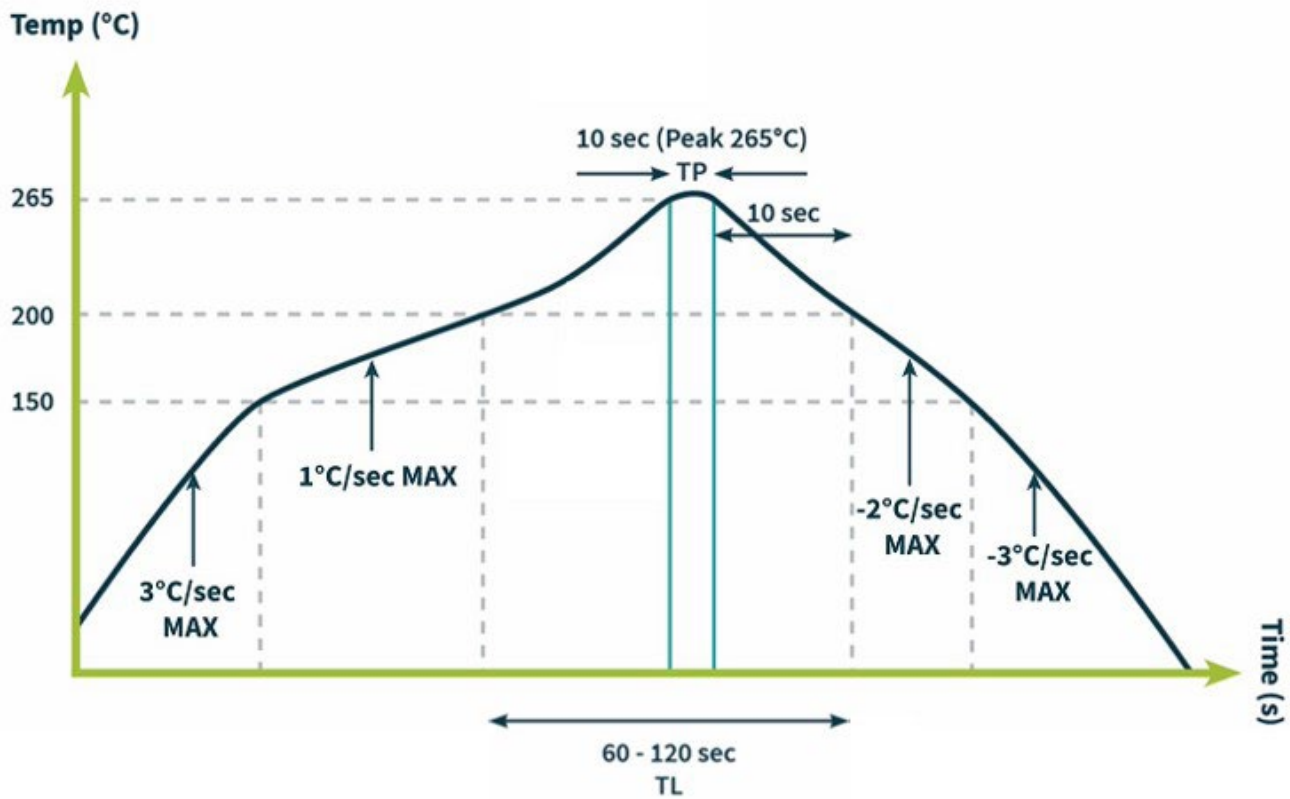

*Temperatures listed within a tolerance of +/- 10° C

Smaller components are typically mounted on the first pass, however, we do advise mounting the- when placing larger components on the board during subsequent reflows.

7. Antenna Characteristics

7.1 Test Setup

AUT



Vector Network Analyzer

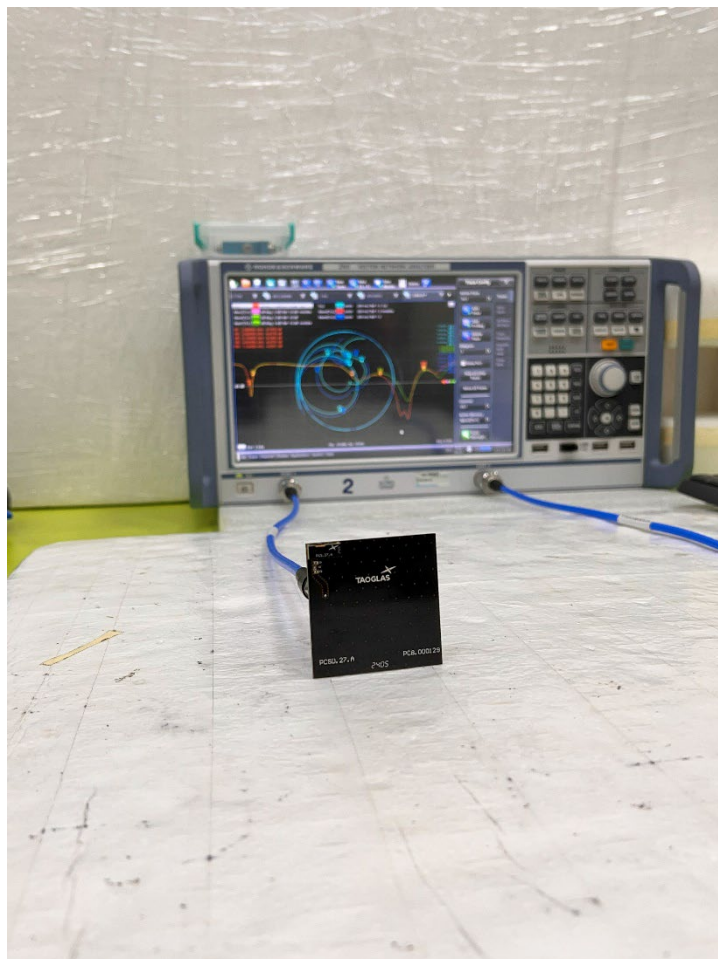

VNA Test Set-up on a 50x50mm Ground Plane

7.2 Return Loss

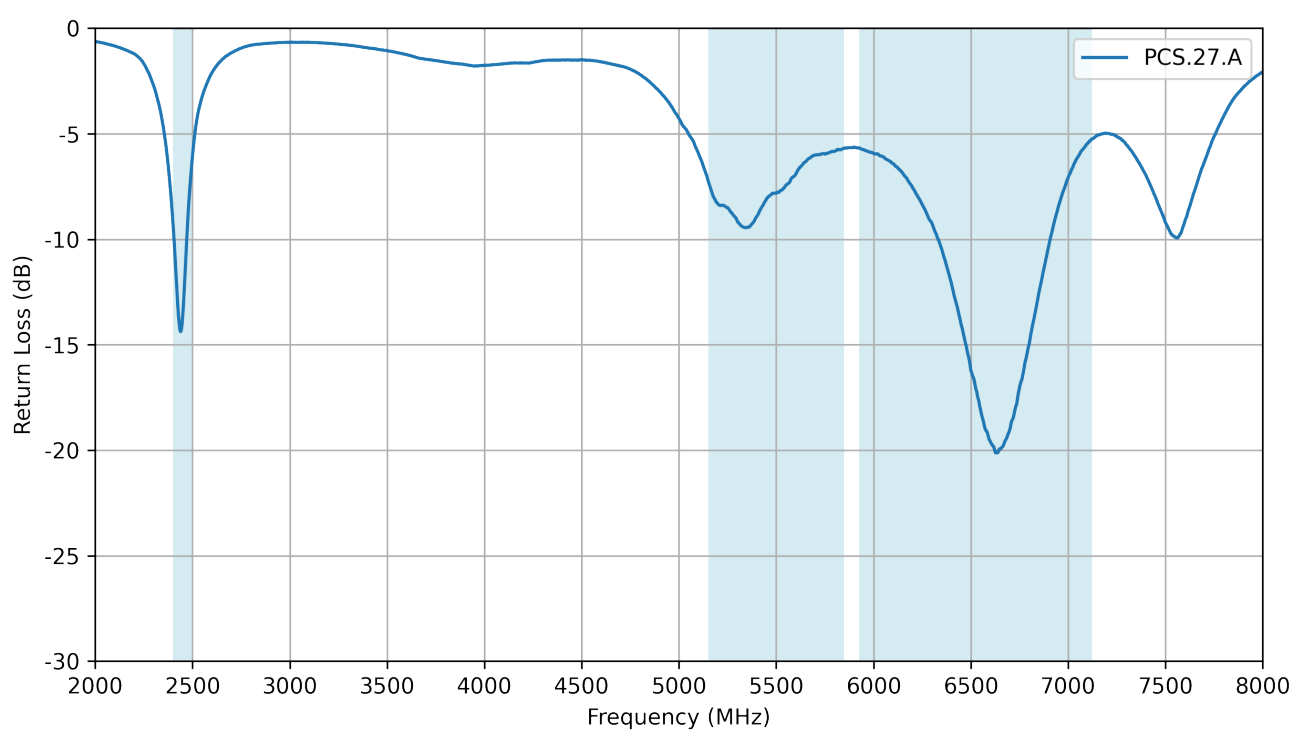

7.3 VSWR

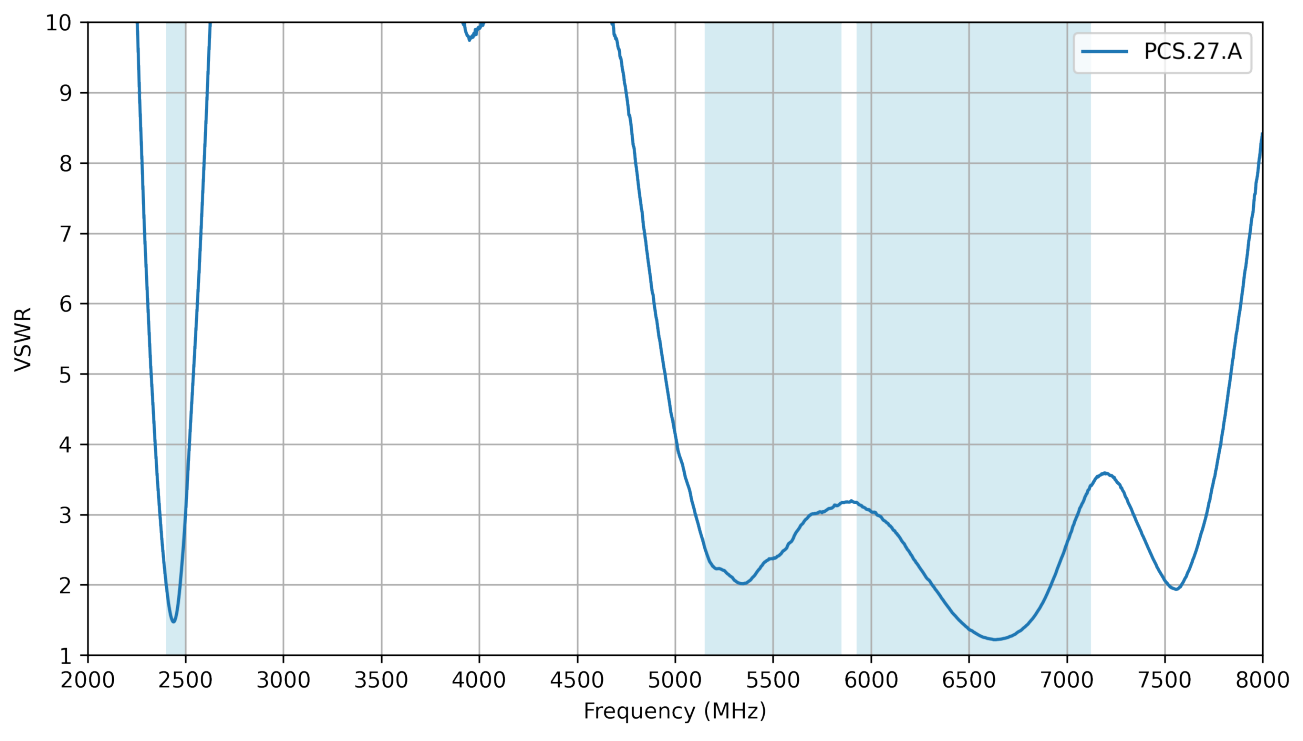

7.4 Efficiency

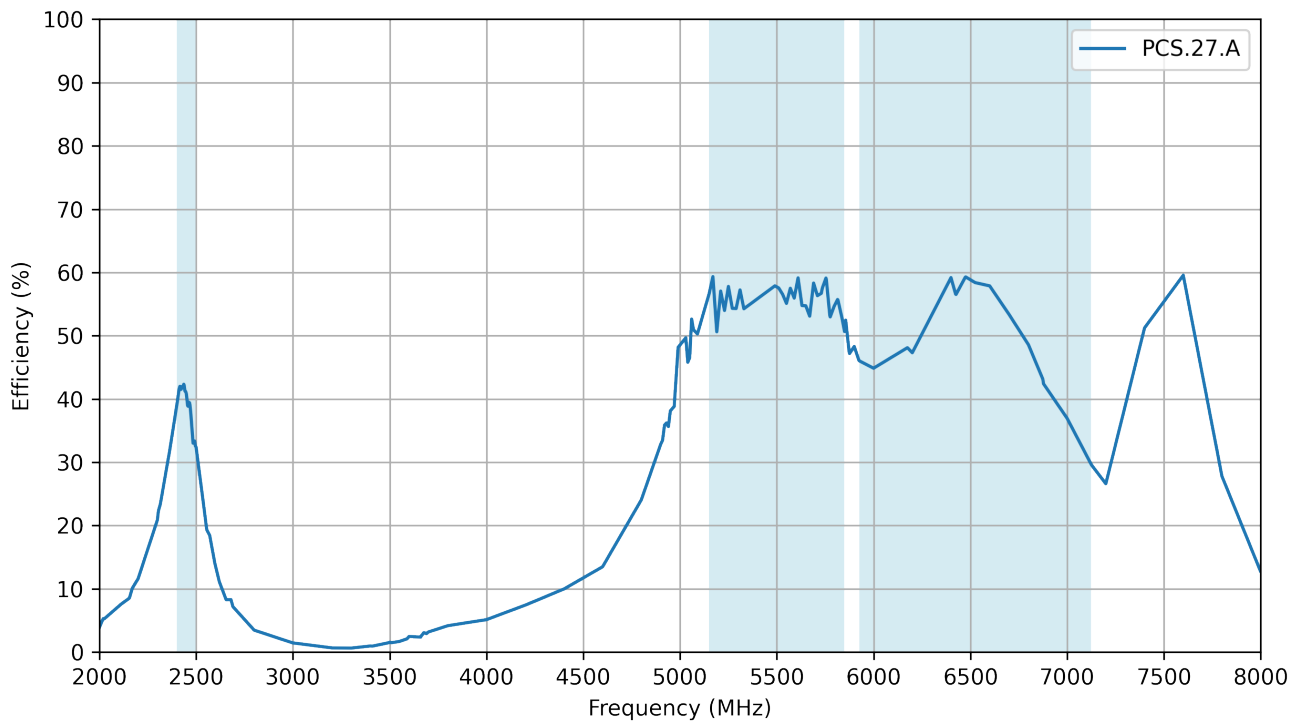

7.5 Average Gain

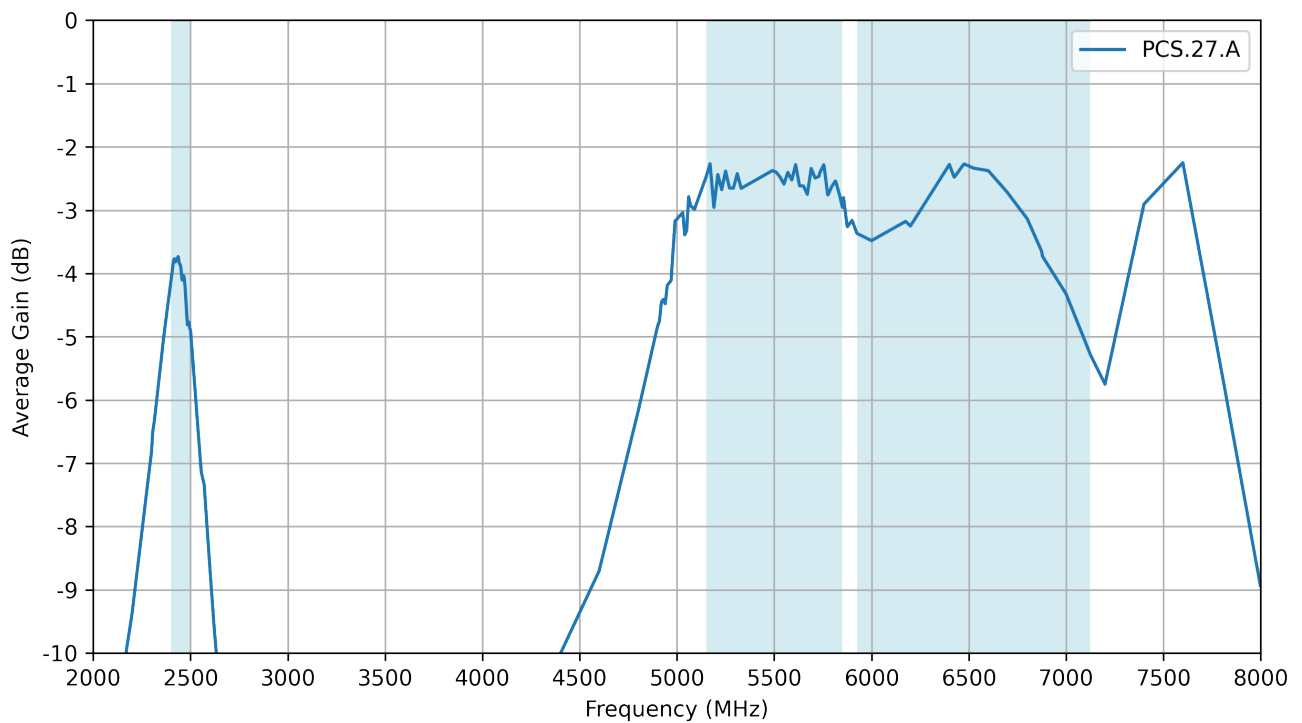

7.6 Peak Gain

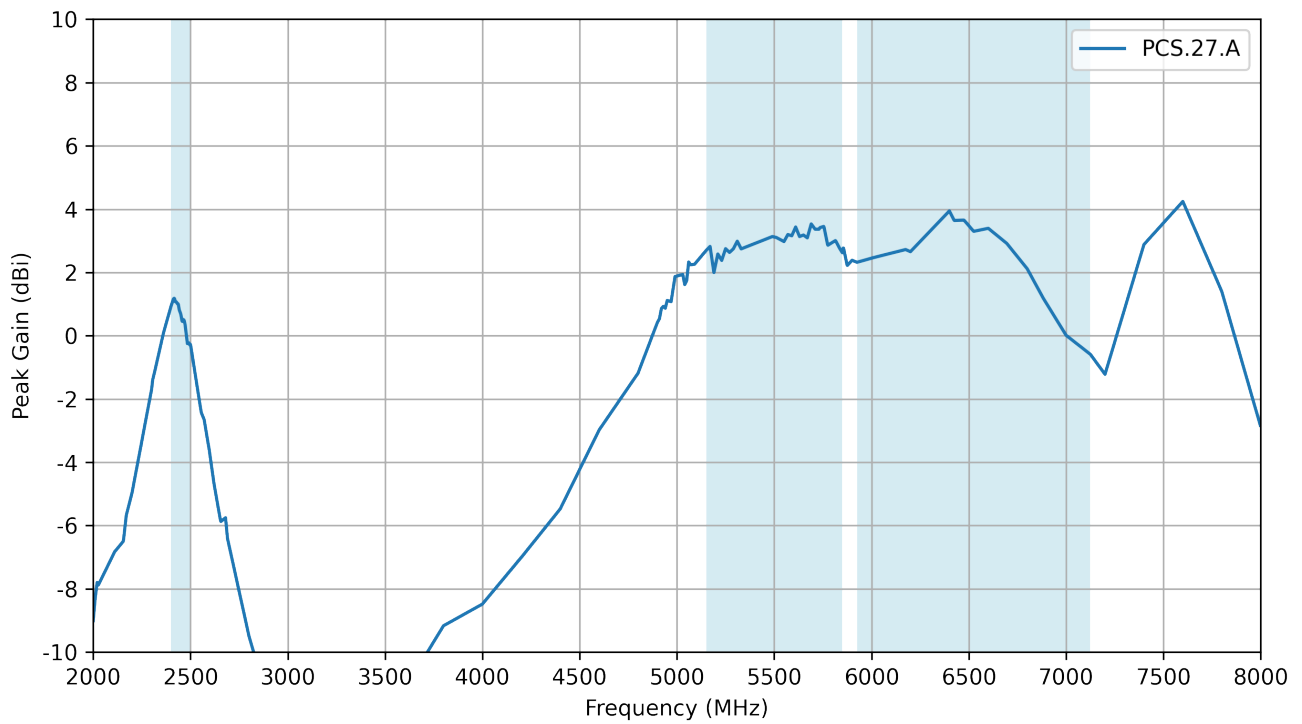

8. Radiation Patterns

8.1 Test Setup

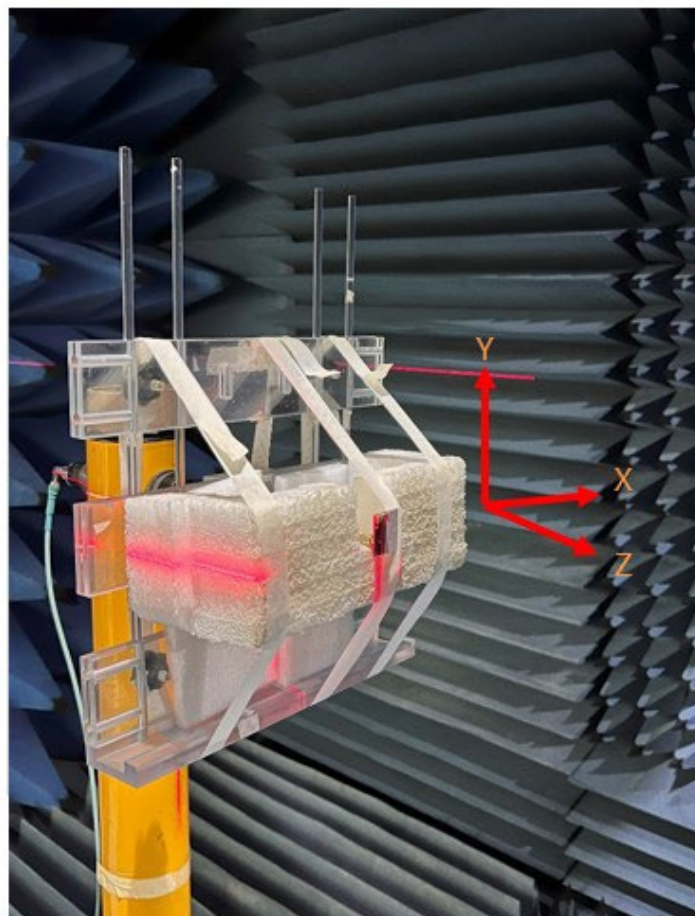
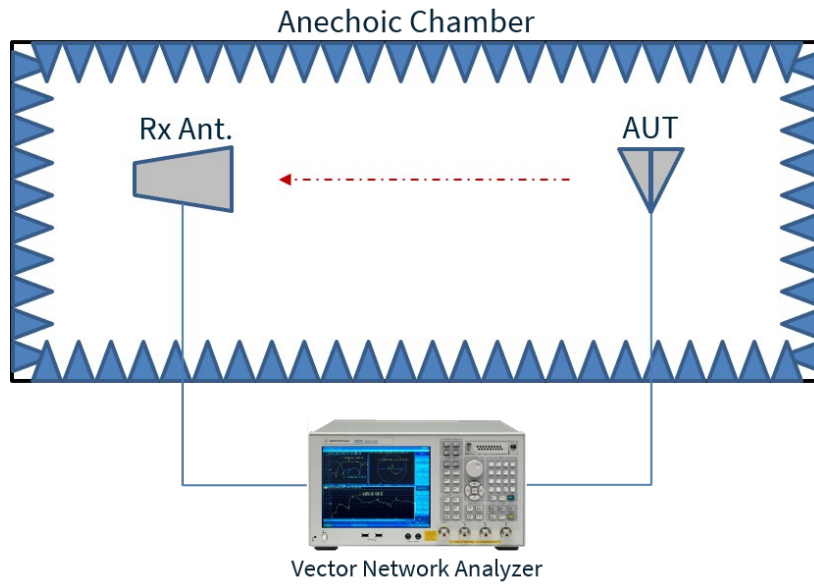

Chamber Test Set-up on a 50x50mm Ground Plane

8.2 PCS.27.A Patterns at 2450 MHz

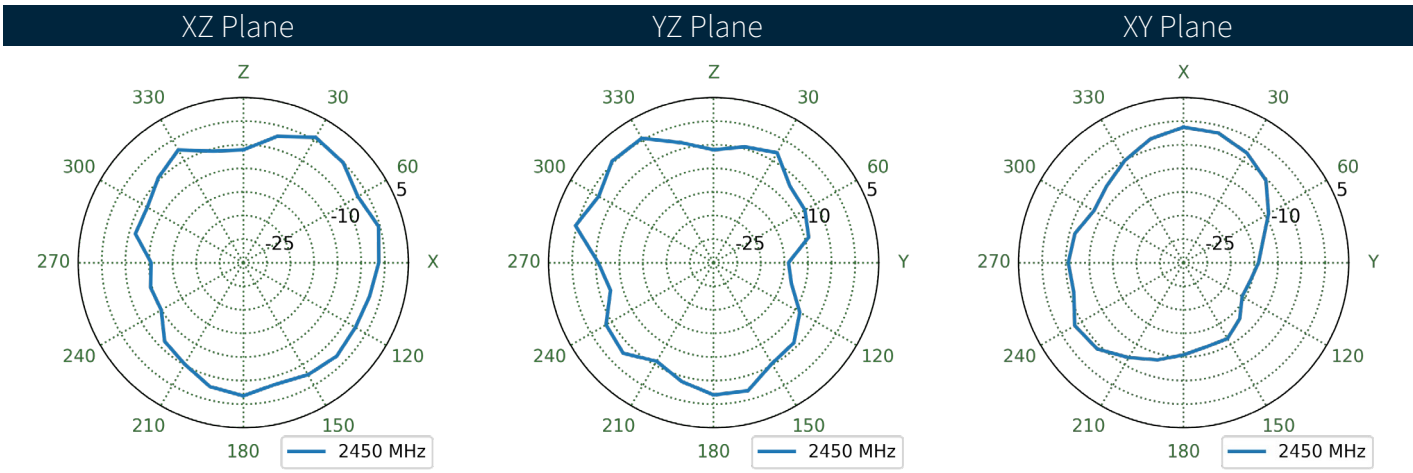
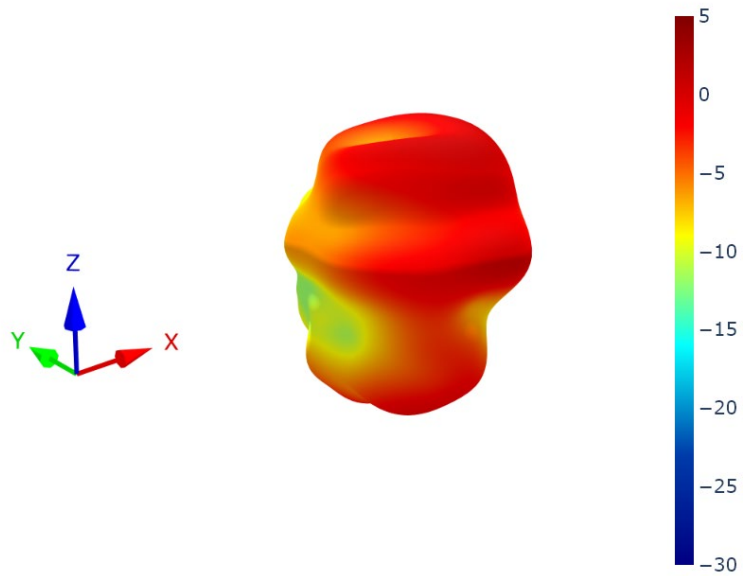

8.3 PCS.27.A Patterns at 5500 MHz

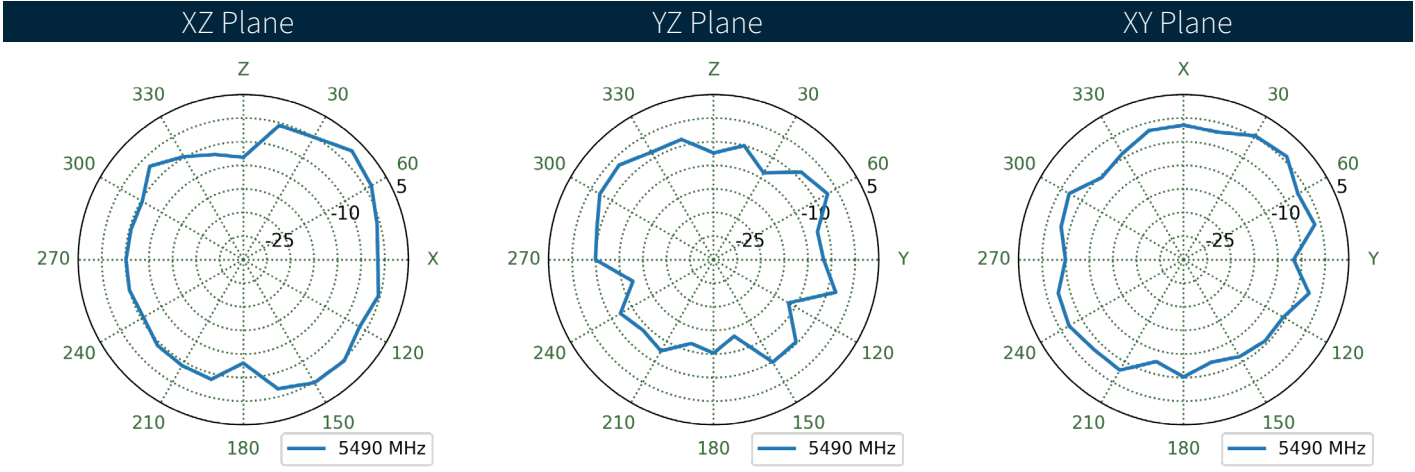
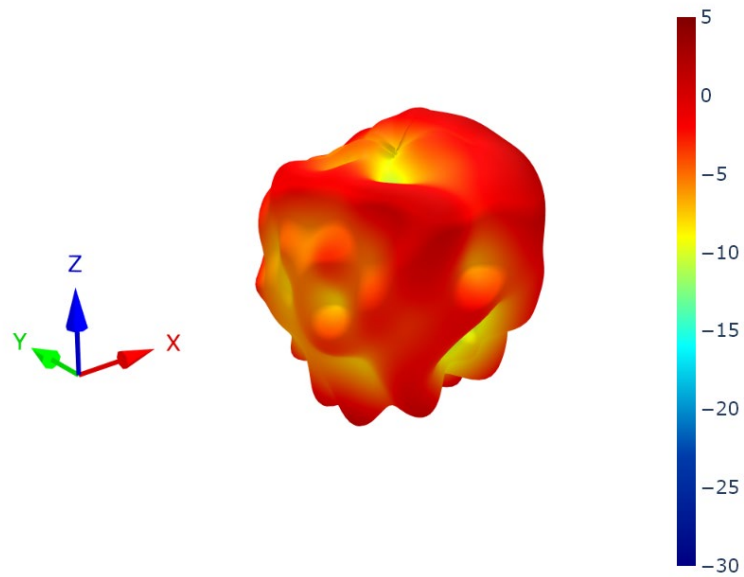

8.4 PCS.27.A Patterns at 6525 MHz

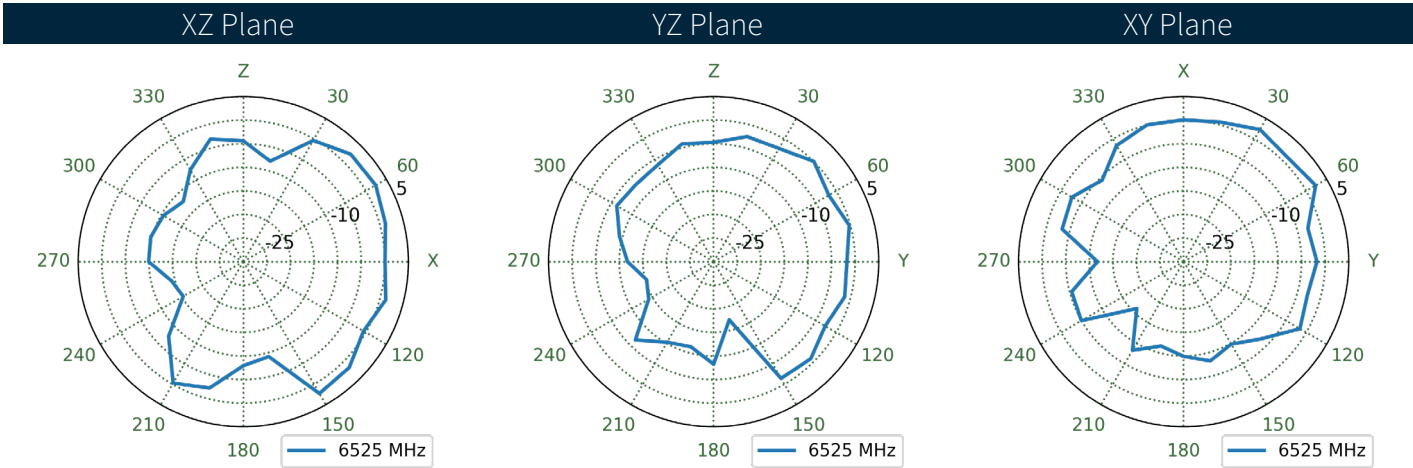
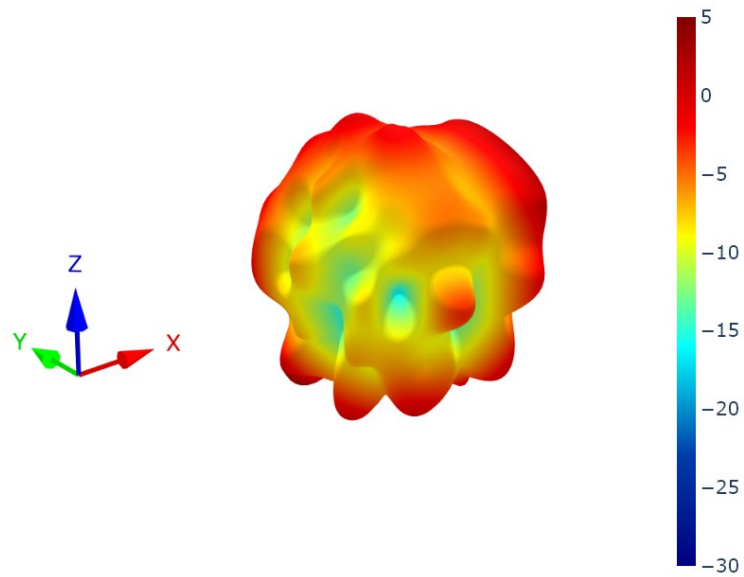

Changelog for the datasheet

SPE-24-8-125 – PCS.27.A

Revision: A (Original First Release)

Date: 2024-06-07

Notes: Initial Release

Author: Gary West

Previous Revisions



www.taoglas.com

