



# TAOGLAS®



# Datasheet

**Part No:**  
TG.08.0113

**Description**

Compact, Passive Monopole Terminal Mount Antenna for Cellular and GNSS

**Features:**

High efficiency from 698 to 2700MHz.

360° rotatable with durable brass hinge

Compatible with:

- 2G / 3G / 4G Global Bands
- GNSS (GPS / GLONASS / BeiDou / Galileo)

Standard Terminal Antenna with SMA(M) connector

Compact Design - 72mm Fully Extended

CE Certified and RoHs & Reach Compliant

<b>1.</b>	<b>Introduction</b>	<b>3</b>
<b>2.</b>	<b>Specification</b>	<b>4</b>
<b>3.</b>	<b>Mechanical Drawing</b>	<b>6</b>
<b>4.</b>	<b>Installation Recommendation</b>	<b>7</b>
<b>5.</b>	<b>Packaging</b>	<b>8</b>
<b>6.</b>	<b>Antenna Characteristics</b>	<b>9</b>
<b>7.</b>	<b>Radiation Patterns</b>	<b>13</b>
<hr/>		
	Changelog	62

Taoglas makes no warranties based on the accuracy or completeness of the contents of this document and reserves the right to make changes to specifications and product descriptions at any time without notice. Taoglas reserves all rights to this document and the information contained herein. Reproduction, use or disclosure to third parties without express permission is strictly prohibited.

Ireland & USA  
ISO 9001:2015  
Certified



Taiwan  
ISO 9001:2015  
Certified



# 1. Introduction



The Taoglas TG.08 is a compact, high-efficiency monopole antenna designed to offer wide coverage across both cellular and GNSS frequencies. With a robust yet compact design, the TG.08 is ideal for applications such as vehicle tracking systems, telematics devices, remote monitoring solutions, and routers, where reliable performance is crucial for seamless connectivity.

Supporting both cellular and GNSS functions, the TG.08 is particularly well-suited for use with cellular modules that require Assisted GPS functionality, providing flexibility across various device types. Whether for tracking, telemetry, or remote diagnostics, the TG.08 ensures efficient and consistent performance.

At just 72mm in length, the antenna operates efficiently across a wide frequency range from 700MHz to 2700MHz, covering 4G/3G/2G cellular bands and GNSS constellations, including GPS, GLONASS, BeiDou, and Galileo. Its design maximizes efficiency, achieving up to 73% at GPS and 67% at LTE bands when connected to a ground plane.

The TG.08 is optimized for integration with the ground plane of the device's mainboard or its metal enclosure, ensuring the best possible performance. The sturdy brass hinge allows the antenna to be oriented in multiple directions, enabling maximum coverage with minimal setup effort.

Perfect for dual coverage needs, the TG.08 combines cellular and GNSS capabilities in a compact package with an SMA(M) connector, making it the ideal choice for applications requiring both types of connectivity in a space-constrained environment.

For more information or samples, or to learn how to integrate with your device, please contact your local Taoglas Customer Support Team.

## 2. Specification

Electrical									
Band	Frequency (MHz)	Measurement	Efficiency (%)	Average Gain (dB)	Peak Gain (dBi)	Impedance	Polarization	Radiation Pattern	Max. input power
5GNR/4G Band71	617-698	15x9cm Ground Plane Bent	38.8	-4.11	1.39	50 Ω	Linear	Omni directional	10W
		15x9cm Ground Plane Straight	54.7	-2.62	2.30				
		30x30cm Ground Plane (Edge) Bent	26.9	-5.70	1.33				
		30x30cm Ground Plane (Edge) Straight	40.0	-3.98	2.11				
		30x30cm Ground Plane Bent	4.1	-13.87	-9.12				
		30x30cm Ground Plane Straight	11.2	-9.52	-4.96				
		Free Space Bent	19.0	-7.20	0.11				
		Free Space Straight	22.6	-6.45	1.04				
4G/3G Band 12,13,14,17, 28,29	698-806	15x9cm Ground Plane Bent	68.9	-1.62	2.81	50 Ω	Linear	Omni directional	10W
		15x9cm Ground Plane Straight	76.7	-1.15	2.81				
		30x30cm Ground Plane (Edge) Bent	63.9	-1.95	3.55				
		30x30cm Ground Plane (Edge) Straight	75.1	-1.25	3.47				
		30x30cm Ground Plane Bent	14.5	-8.39	-2.02				
		30x30cm Ground Plane Straight	37.8	-4.22	1.00				
		Free Space Bent	44.5	-3.52	2.11				
		Free Space Straight	49.6	-3.05	2.74				
4G/3G/NB-IoT/Cat M Band 5,8,18,19,20 ,26,27	824-960	15x9cm Ground Plane Bent	70.0	-1.55	2.61	50 Ω	Linear	Omni directional	10W
		15x9cm Ground Plane Straight	64.6	-1.89	2.17				
		30x30cm Ground Plane (Edge) Bent	77.9	-1.09	3.26				
		30x30cm Ground Plane (Edge) Straight	75.3	-1.23	2.62				
		30x30cm Ground Plane Bent	33.6	-4.74	1.04				
		30x30cm Ground Plane Straight	62.8	-2.02	2.68				
		Free Space Bent	54.6	-2.63	3.37				
		Free Space Straight	53.3	-2.74	3.30				
5GNR/4G Band 21,32,74,75, 76	1427-1518	15x9cm Ground Plane Bent	62.8	-2.02	3.44	50 Ω	Linear	Omni directional	10W
		15x9cm Ground Plane Straight	66.0	-1.81	3.31				
		30x30cm Ground Plane (Edge) Bent	53.5	-2.71	3.96				
		30x30cm Ground Plane (Edge) Straight	52.8	-2.77	3.87				
		30x30cm Ground Plane Bent	32.9	-4.83	1.01				
		30x30cm Ground Plane Straight	16.1	-7.93	-0.68				
		Free Space Bent	35.0	-4.56	0.82				
		Free Space Straight	32.7	-4.86	0.35				
4G/3G Band 1,2,3,4,9,23, 25,35,39,66	1710-2200	15x9cm Ground Plane Bent	67.8	-1.69	3.86	50 Ω	Linear	Omni directional	10W
		15x9cm Ground Plane Straight	67.1	-1.73	3.85				
		30x30cm Ground Plane (Edge) Bent	66.6	-1.77	3.96				

		30x30cm Ground Plane (Edge) Straight	69.8	-1.56	4.20				
		30x30cm Ground Plane Bent	43.9	-3.58	1.77				
		30x30cm Ground Plane Straight	46.1	-3.37	2.12				
		Free Space Bent	60.9	-2.15	4.27				
		Free Space Straight	61.6	-2.10	4.53				
4G/3G Band 7,30,38,40,4 1	2300-2690	15x9cm Ground Plane Bent	65.7	-1.83	3.58				
		15x9cm Ground Plane Straight	65.7	-1.83	3.41				
		30x30cm Ground Plane (Edge) Bent	53.9	-2.68	3.67				
		30x30cm Ground Plane (Edge) Straight	56.6	-2.47	3.55				
		30x30cm Ground Plane Bent	39.8	-4.00	2.04				
		30x30cm Ground Plane Straight	42.3	-3.74	2.43				
		Free Space Bent	50.5	-2.97	2.50				
		Free Space Straight	52.2	-2.82	2.39				

### Mechanical

Antenna Dimensions	Ø10mm x 72mm
Casing	POM
Connector	SMA(M)
Weight	6g

### Environmental

Operation Temperature	-40°C ~ + 85°C
Storage Temperature	-40°C ~ + 85°C
Humidity	Non-condensing 65°C 95% RH

### 3. Mechanical Drawing

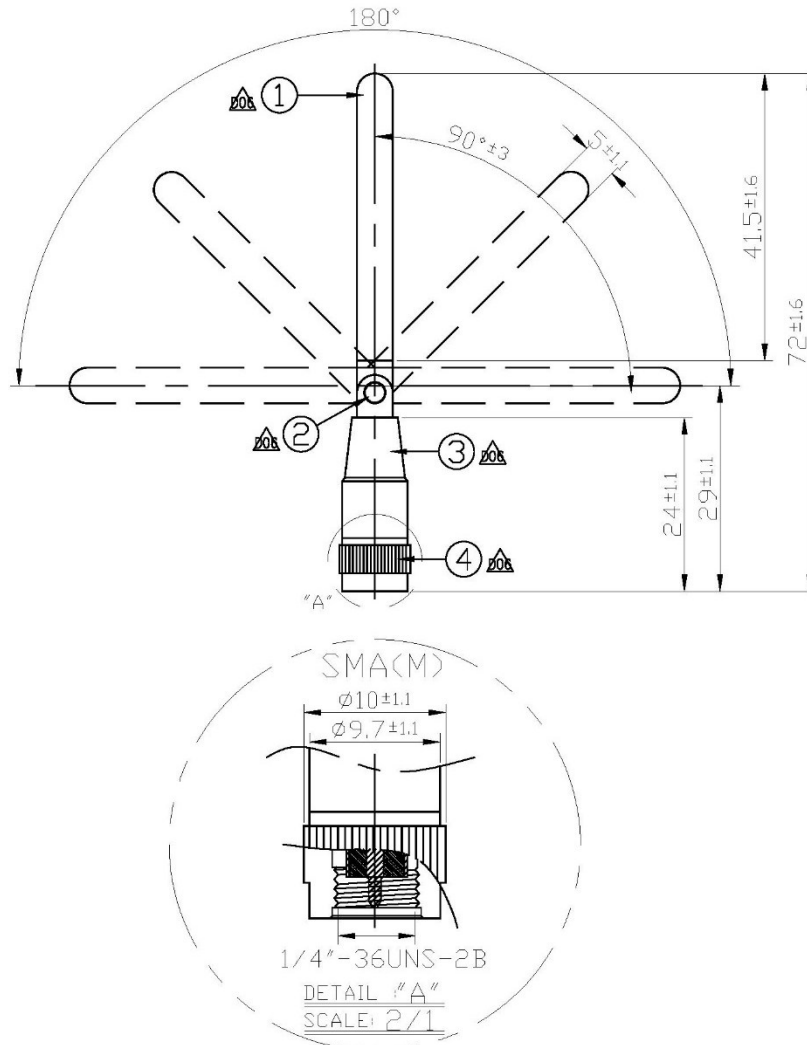

	Name	Material	Finish	QTY
1	Top housing	ABS	Black	1
2	Lower connector	Brass 3604	Ni Plated	1
3	Bottom housing	ABS	Oringe	1
4	Copper joint housing	Brass 3604	Ni Plated	1

## 4. Installation Recommendation

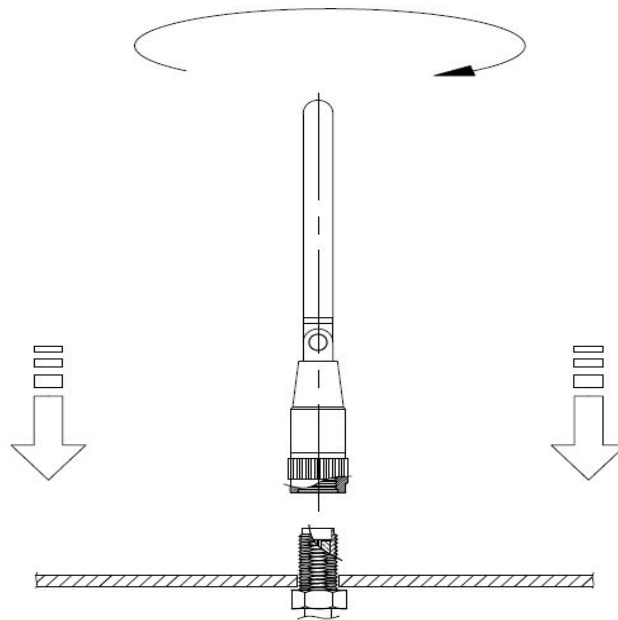

**Hand tighten only!**

Do not use the antenna as a lever when tightening to device.

## 5. Packaging

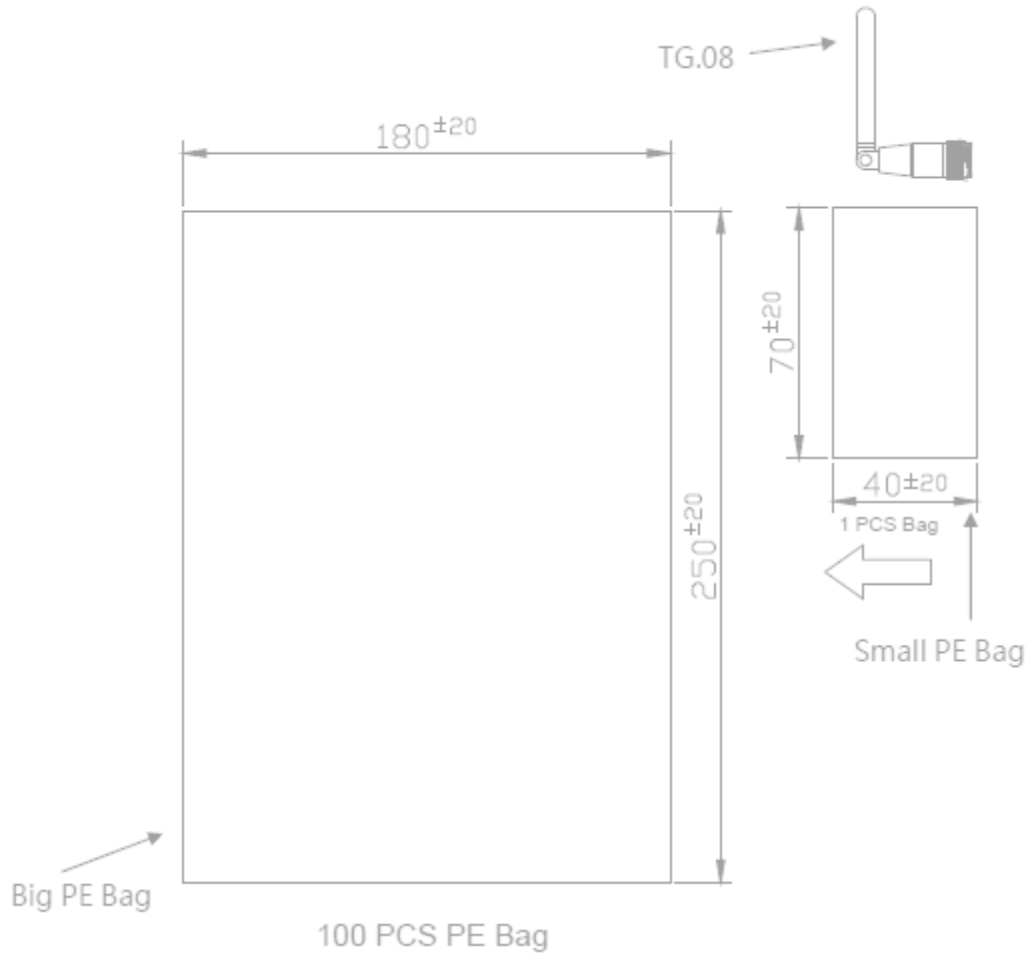



# 6. Antenna Characteristics

## 6.1 Test Setup

AUT



Vector Network Analyzer

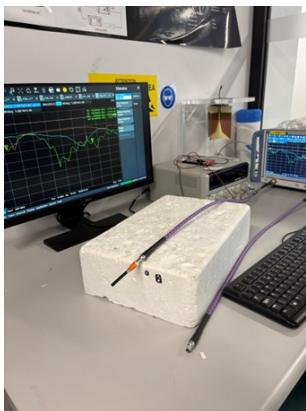

Free Space- Straight

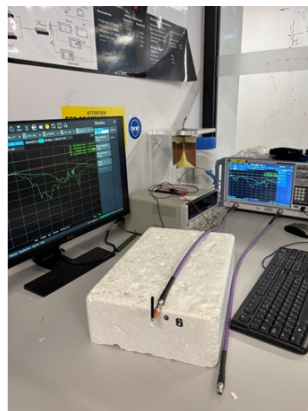

Free Space- Bent



30x30cm Ground Plane (Edge) Bent

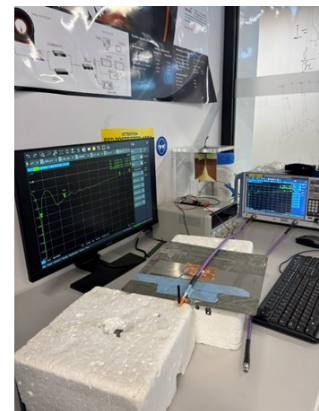

30x30cm Ground Plane (Edge) Straight

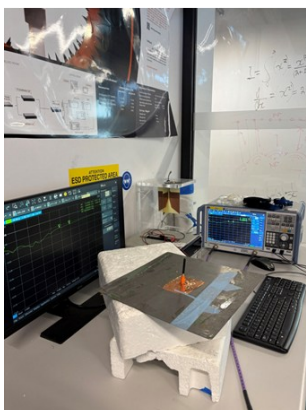

30x30cm Ground Plane (Centre) Straight

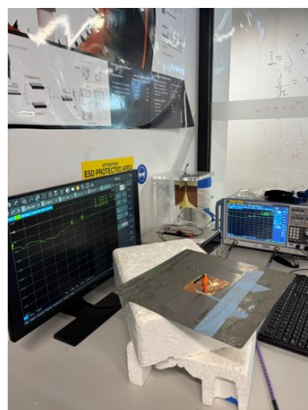

30x30cm Ground Plane (Centre) Bent

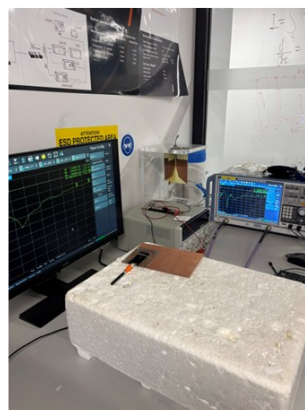

15x9cm Ground Plane Bent

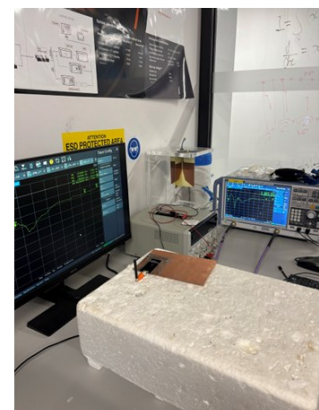

15x9cm Ground Plane Straight

## 6.2 Return Loss

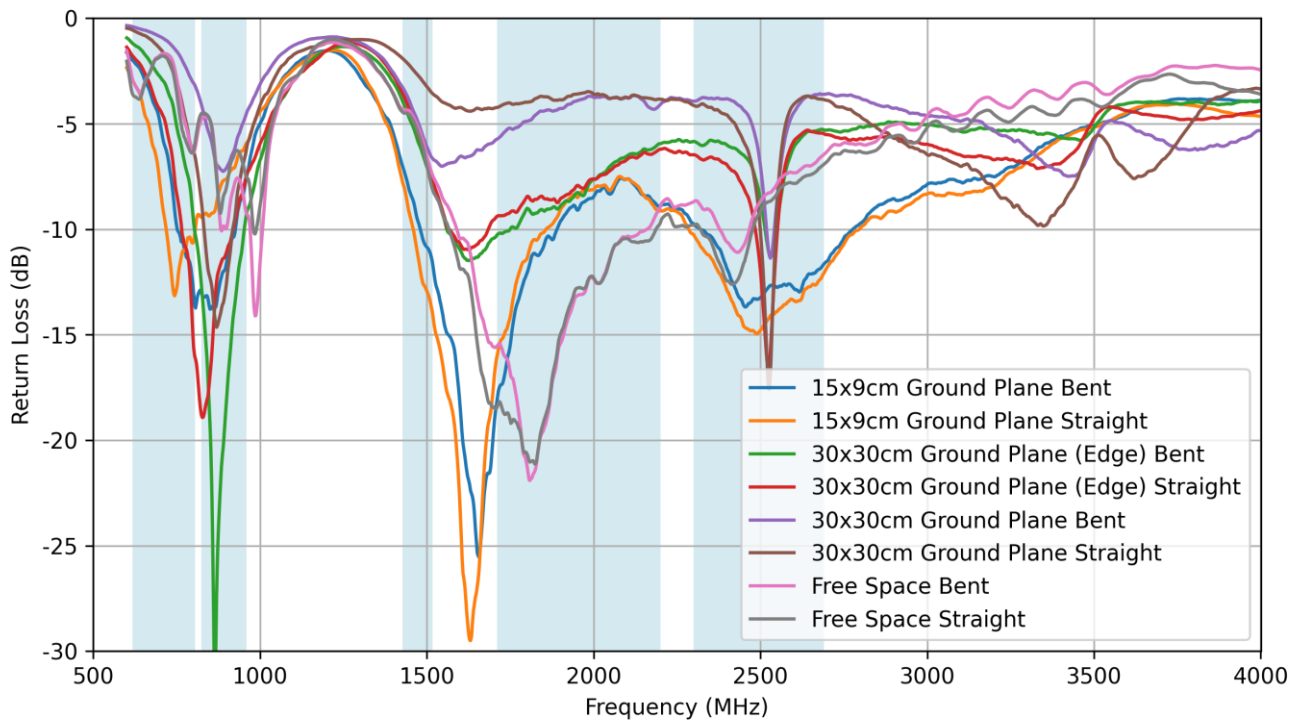

## 6.3 VSWR

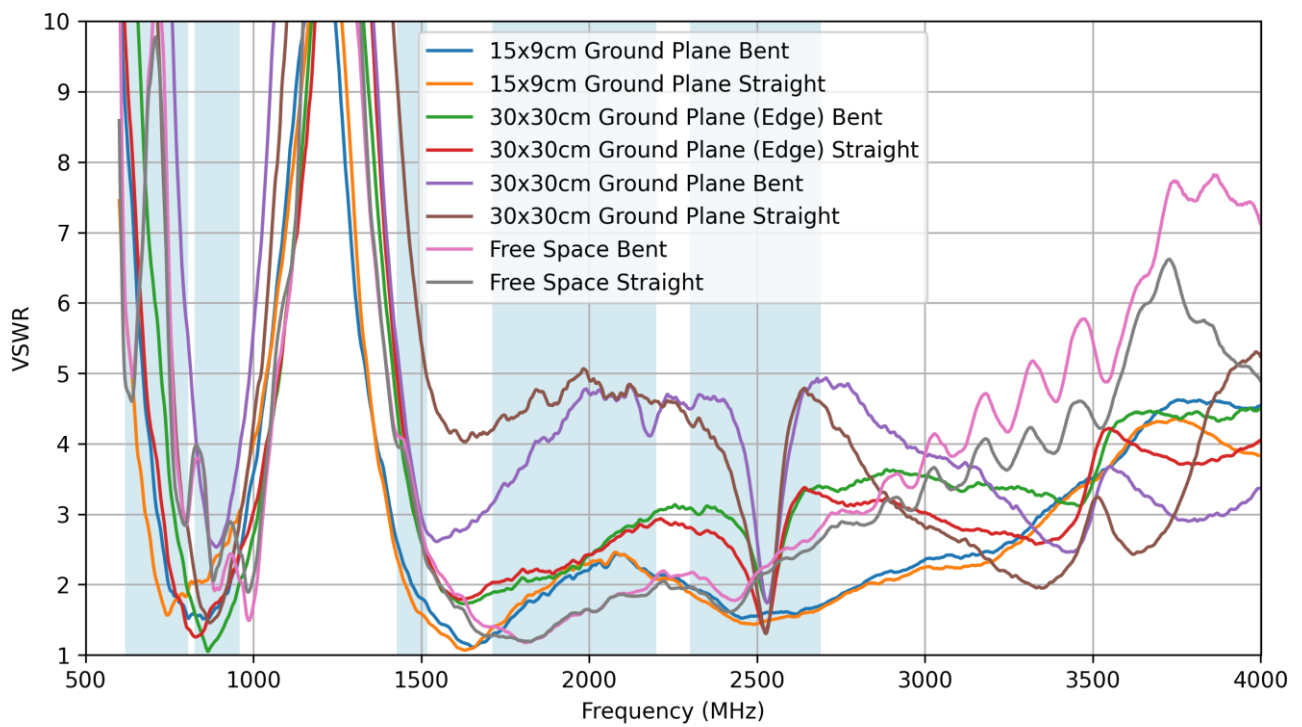

## 6.4 Efficiency

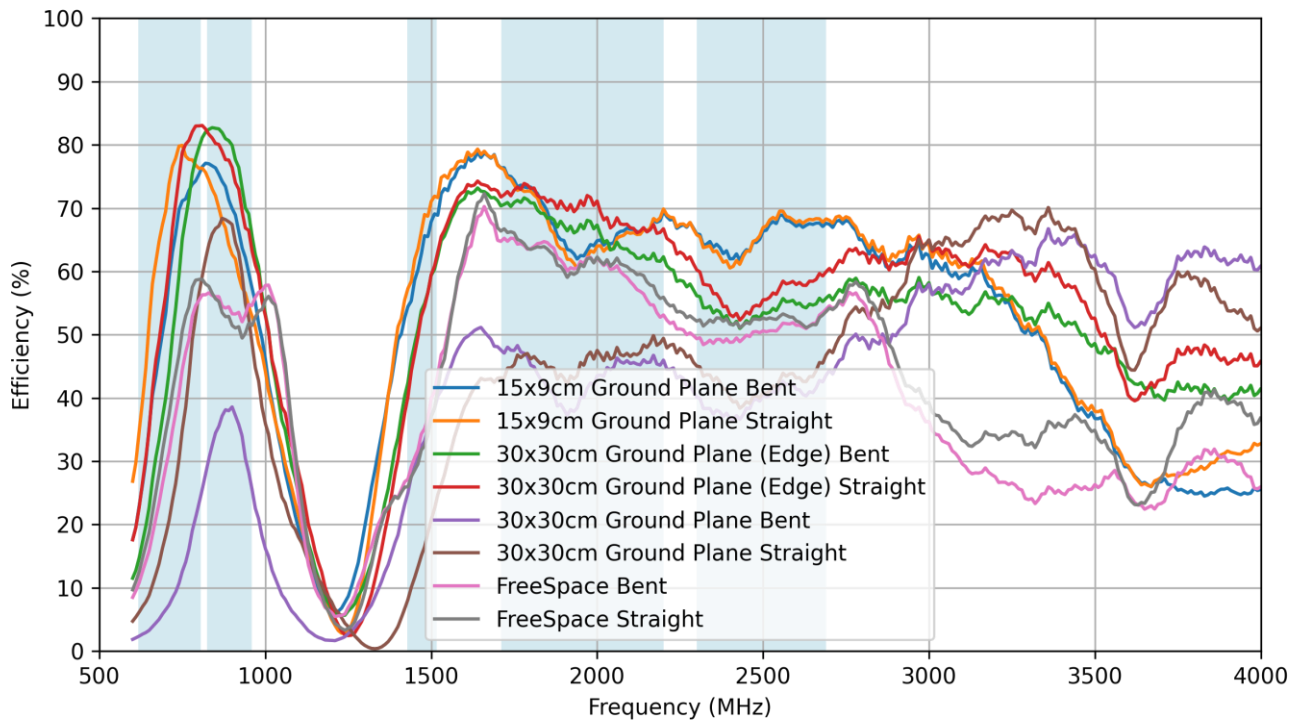

## 6.5 Average Gain

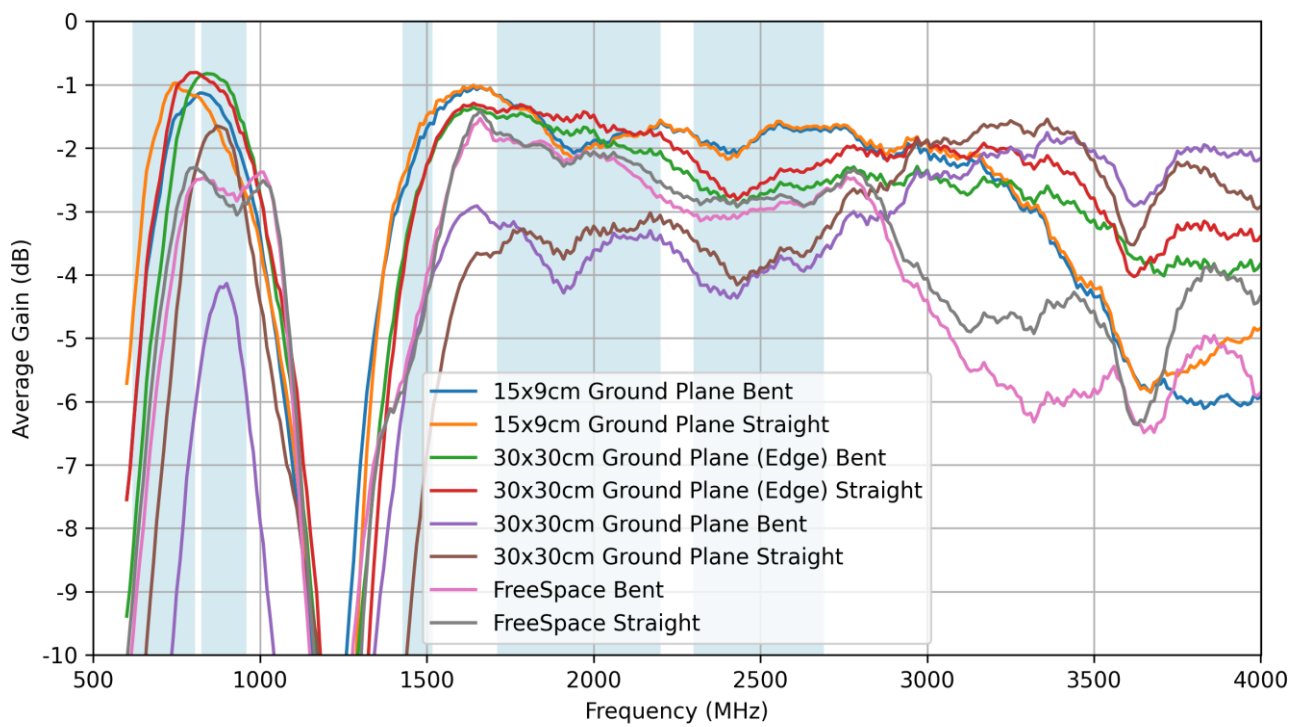

## 6.6 Peak Gain

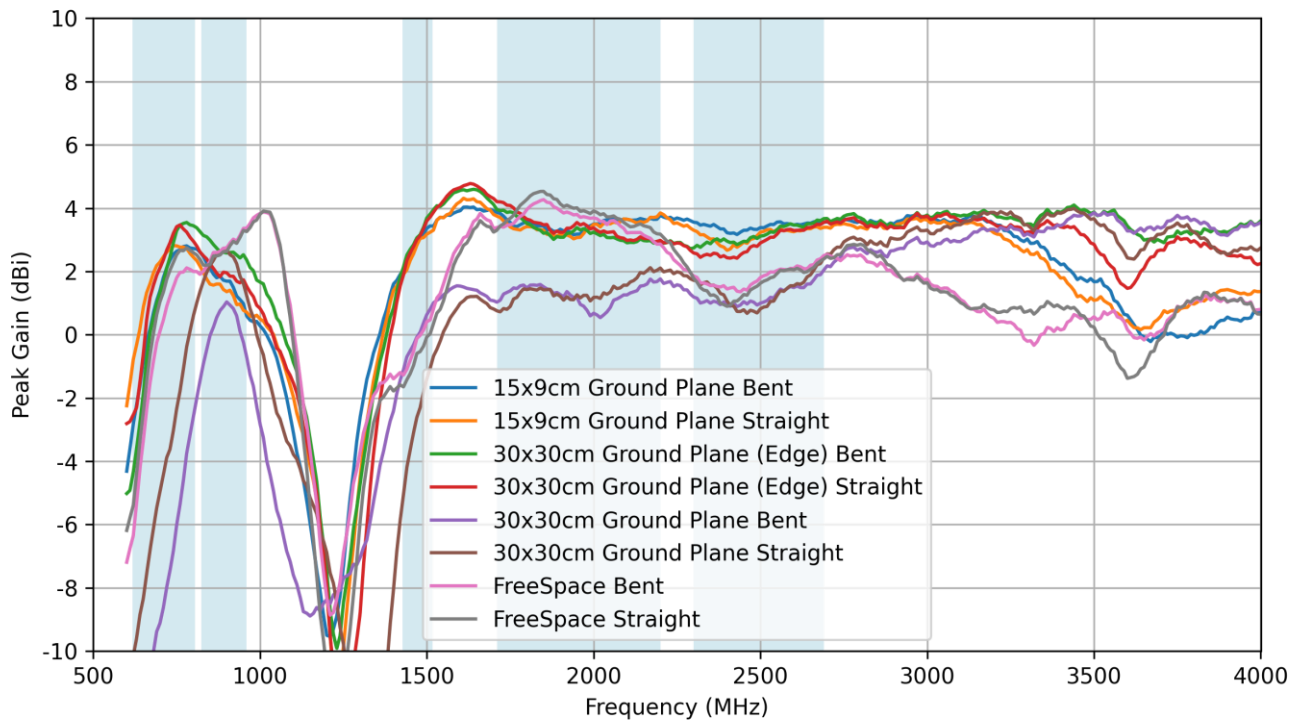

# 7. Radiation Patterns

## 7.1 Test Setup

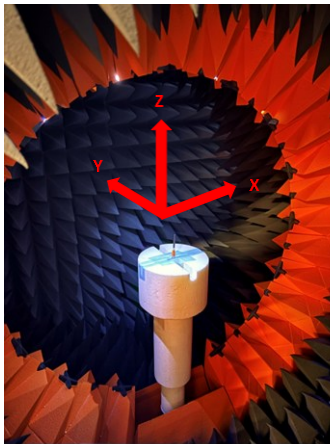
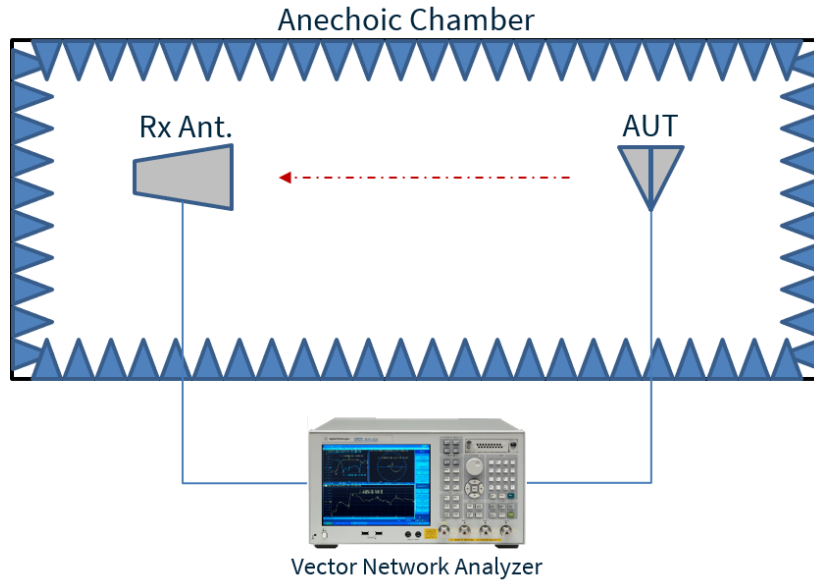

Free Space- Straight

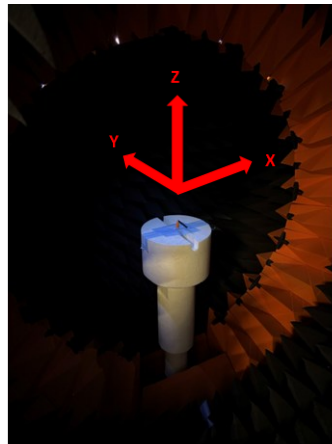

Free Space- Bent

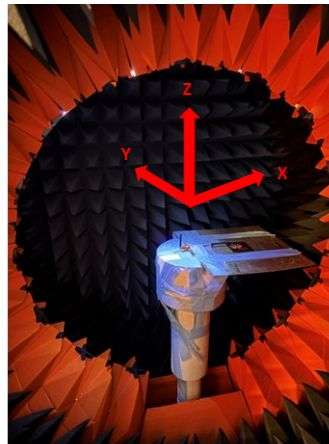

30x30cm Ground Plane  
(Edge) Bent

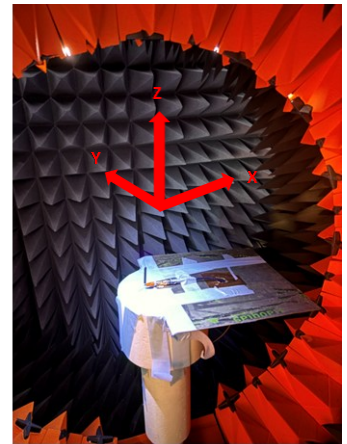

30x30cm Ground Plane  
(Edge) Straight

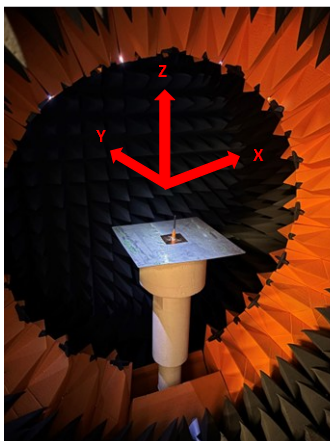

30x30cm Ground Plane  
(Centre) Straight

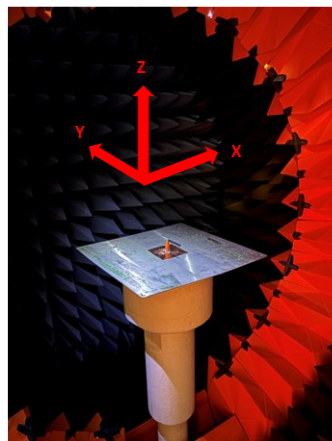

30x30cm Ground Plane  
(Centre) Bent

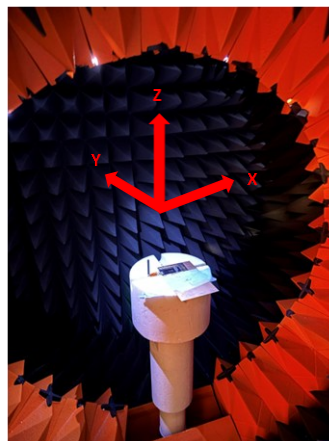

15x9cm Ground Plane Bent

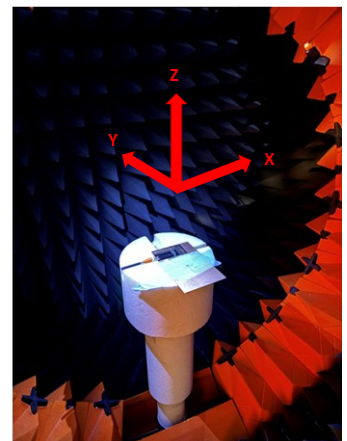

15x9cm Ground Plane Straight

7.2 15x9cm Ground Plane Bent Patterns at 660 MHz

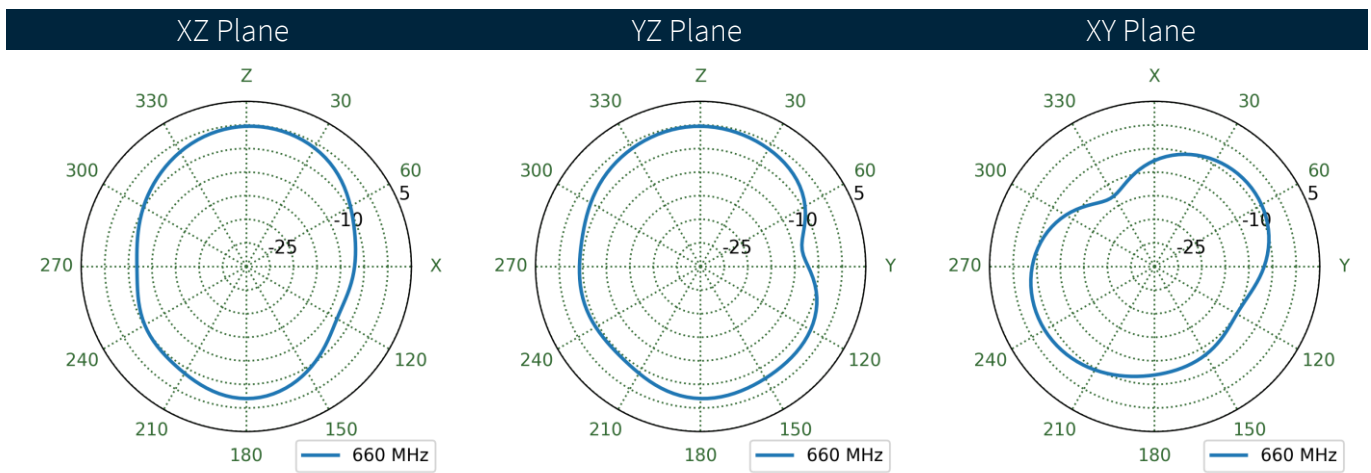
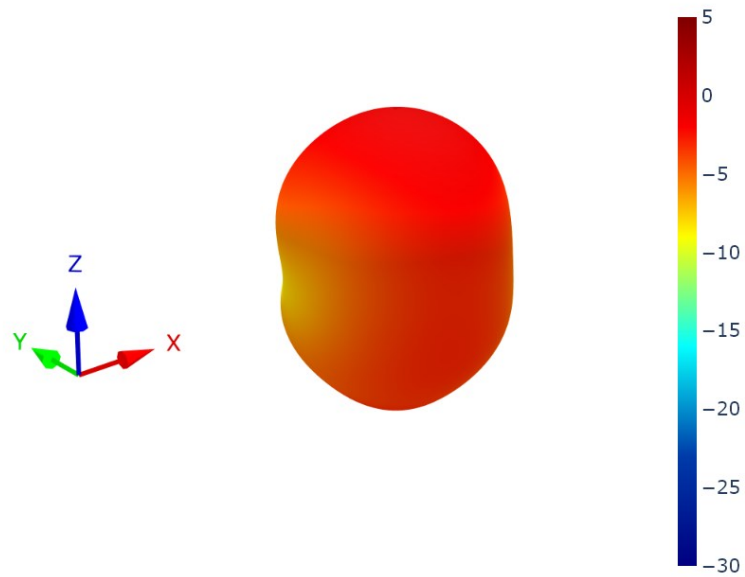

7.3 15x9cm Ground Plane Straight Patterns at 660 MHz

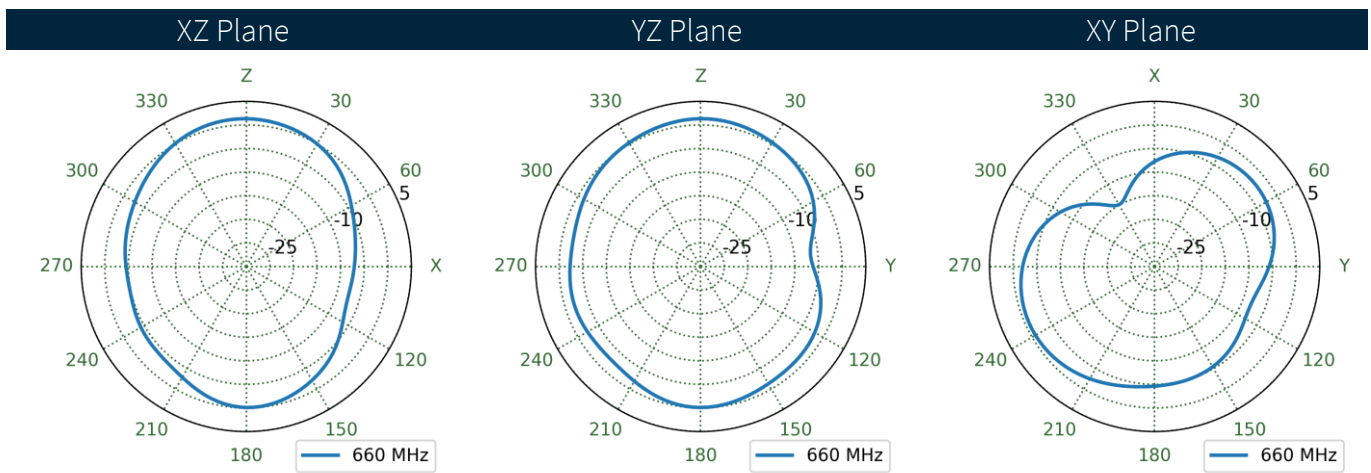
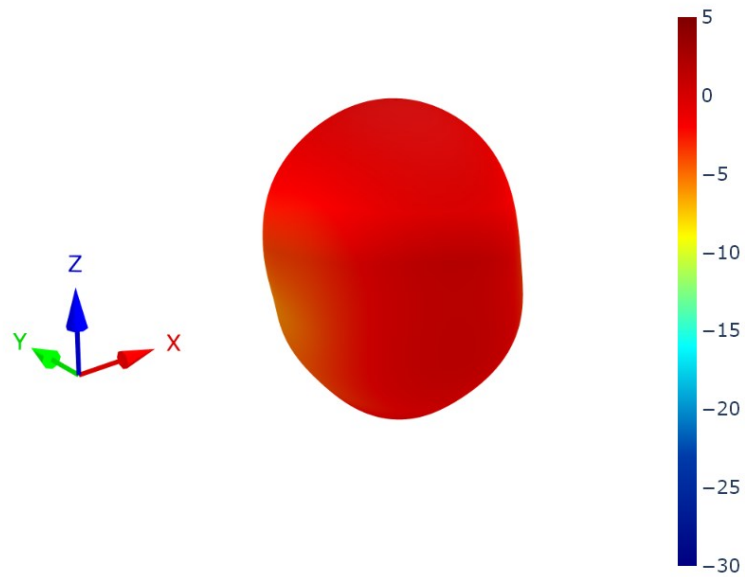

7.4 30x30cm Ground Plane (Edge) Bent Patterns at 660 MHz

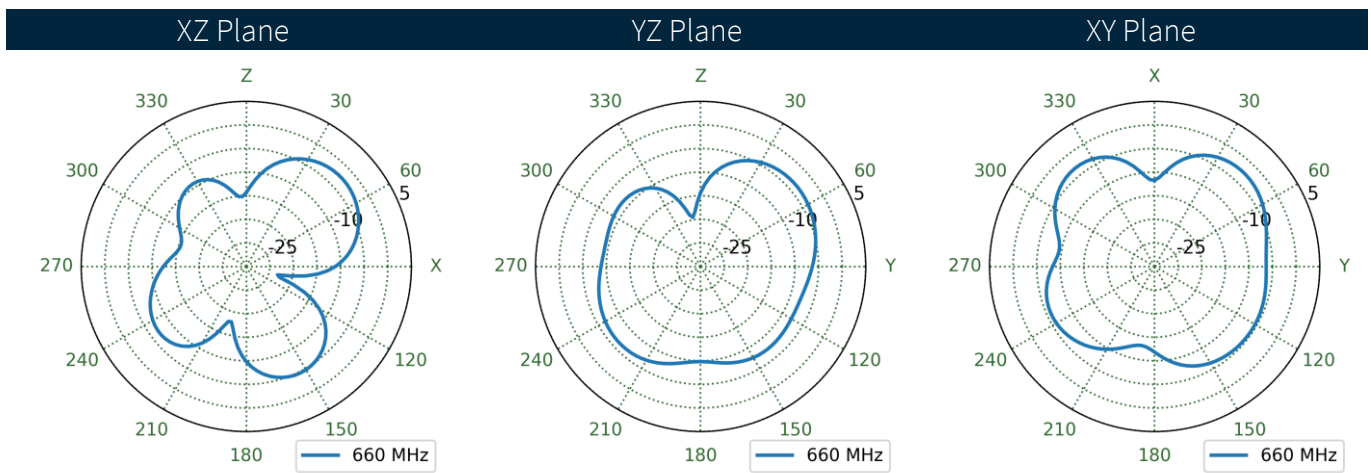
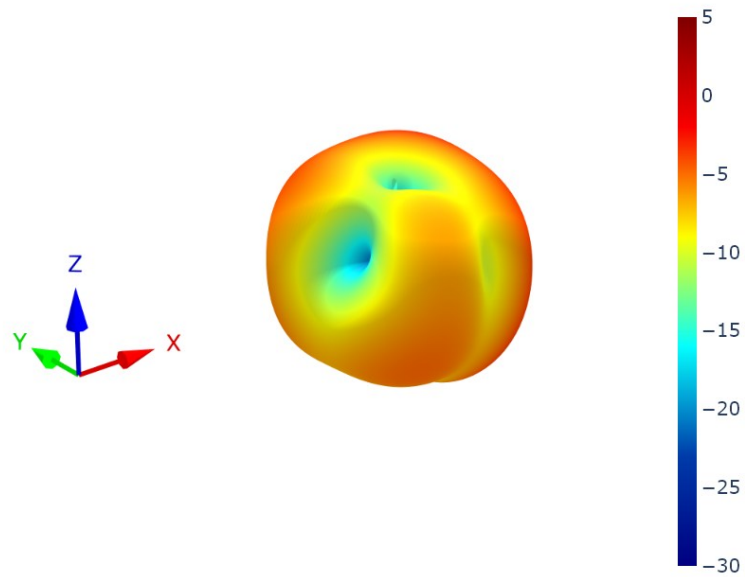



7.5 30x30cm Ground Plane (Edge) Straight Patterns at 660 MHz

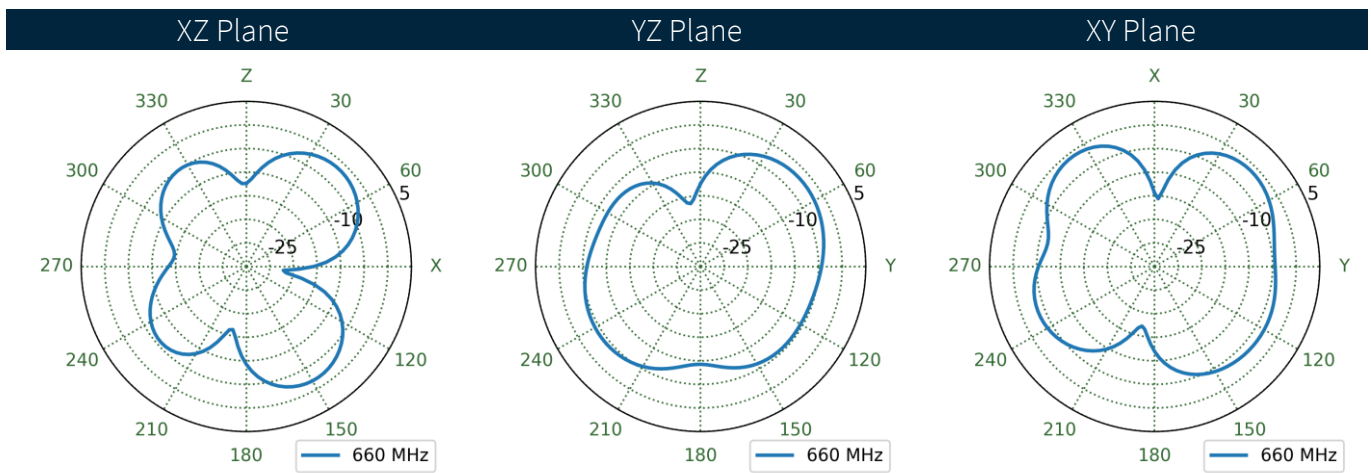
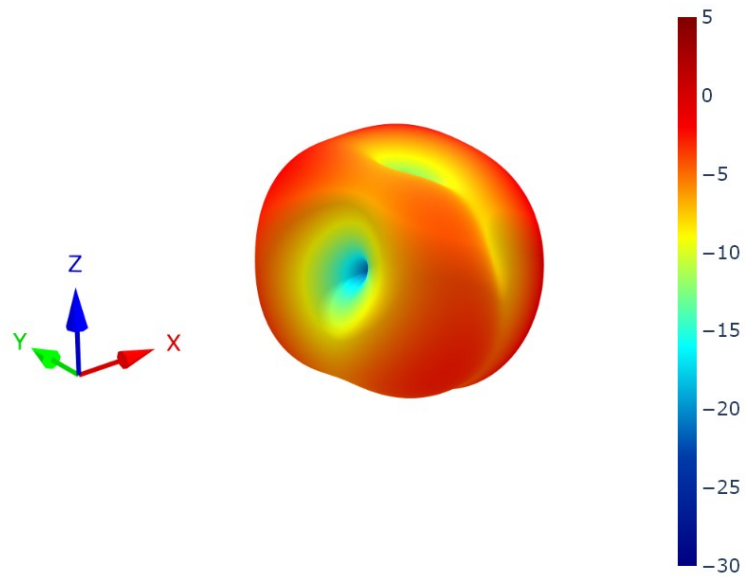

7.6 30x30cm Ground Plane Bent Patterns at 660 MHz

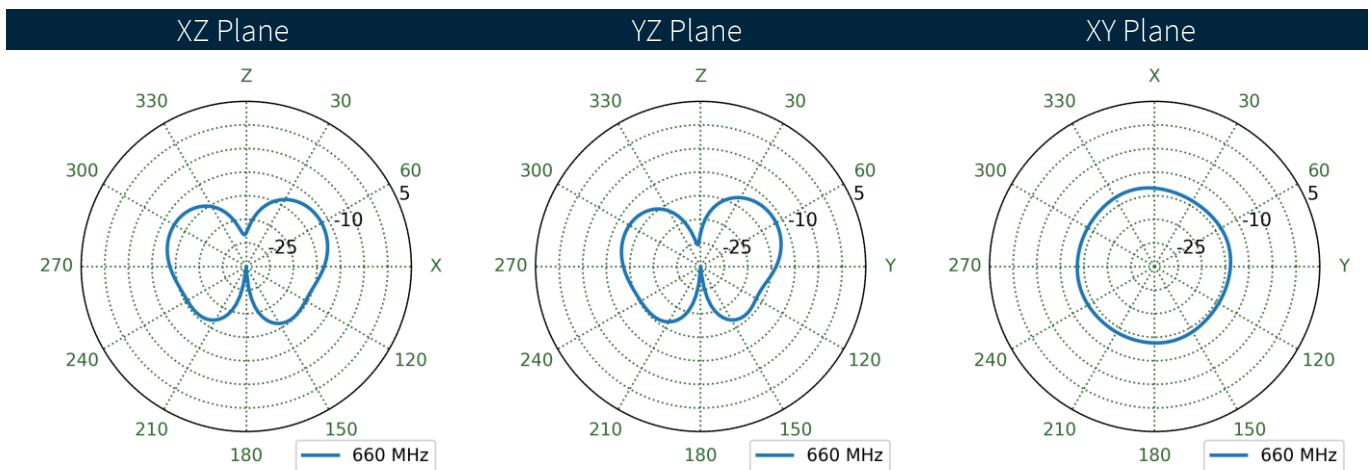
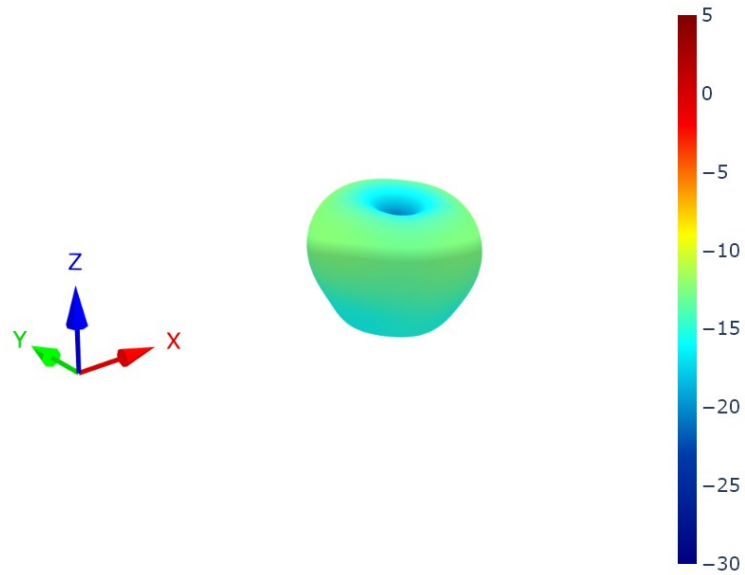

7.7 30x30cm Ground Plane Straight Patterns at 660 MHz

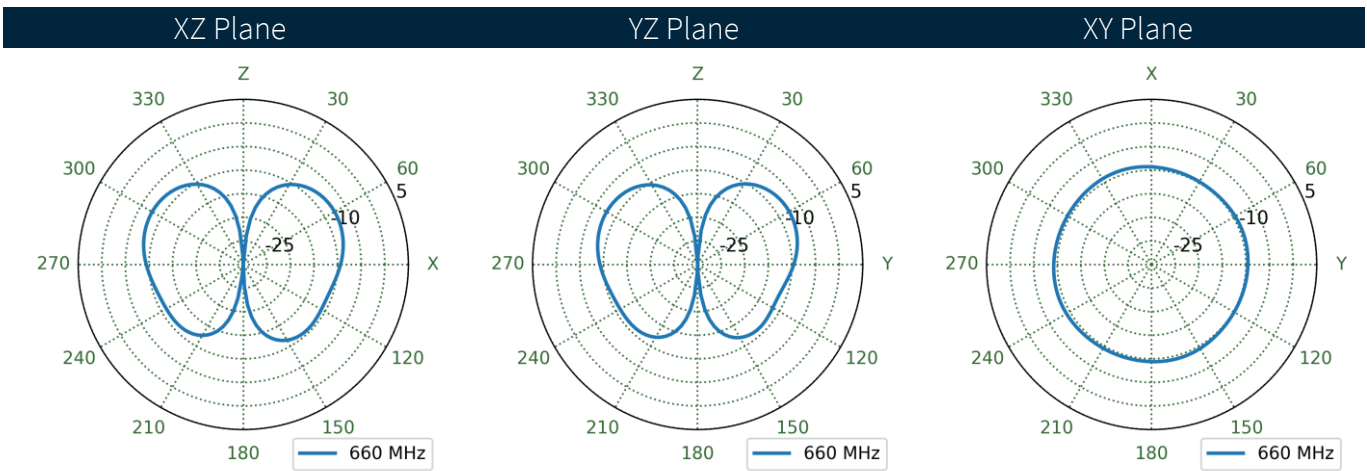
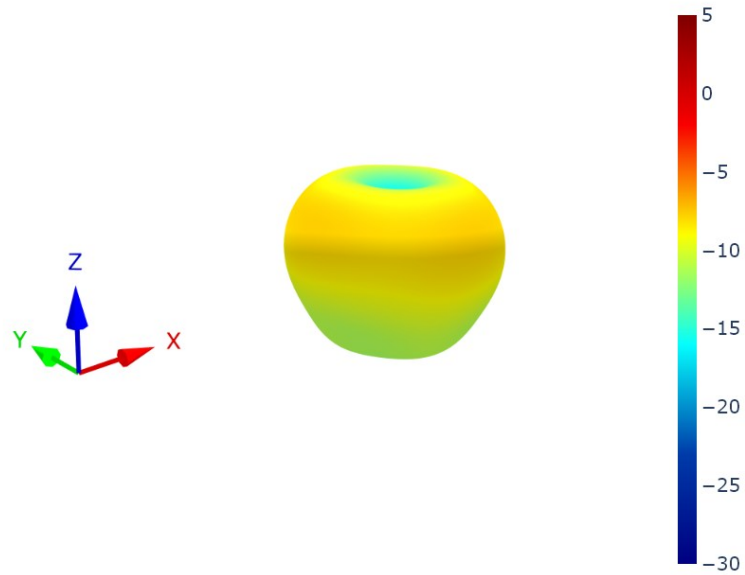

7.8 Free Space Bent Patterns at 660 MHz

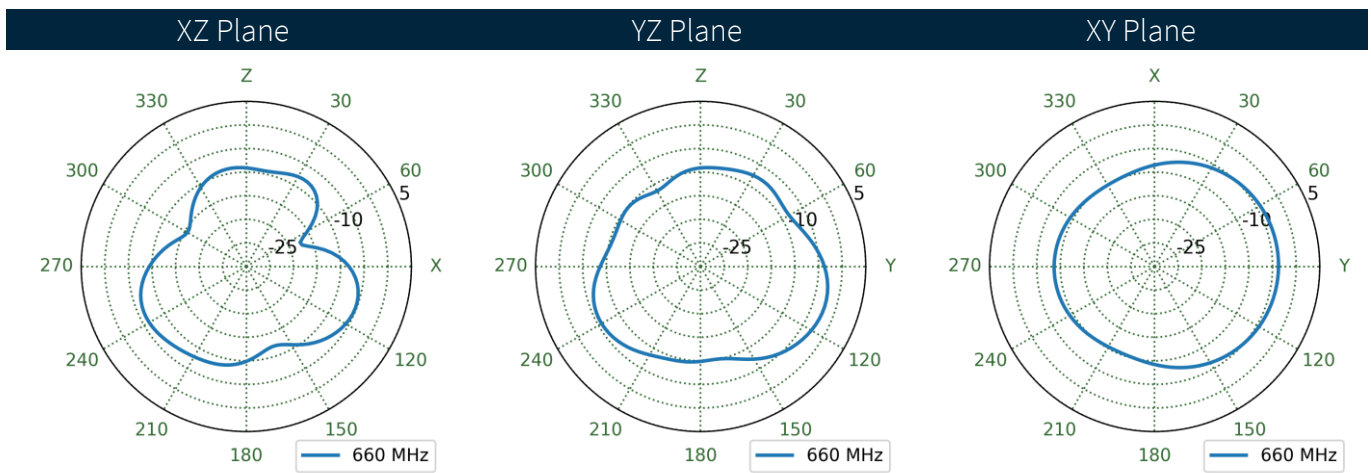
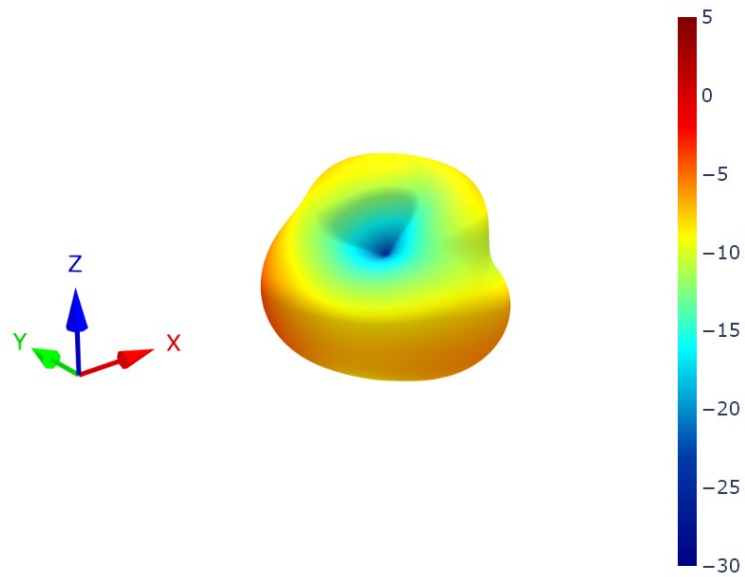

7.9 Free Space Straight Patterns at 660 MHz

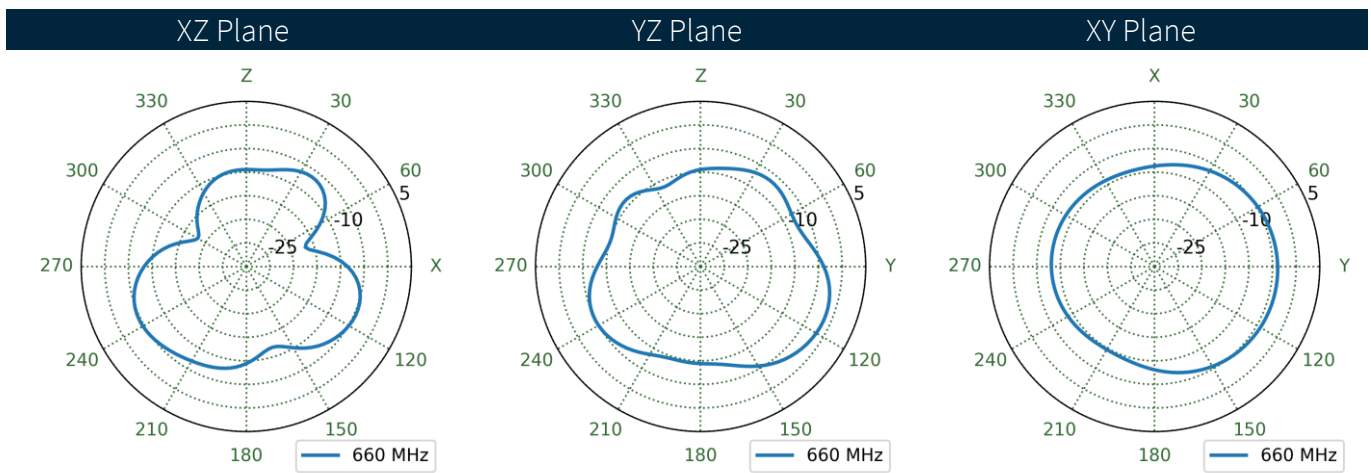
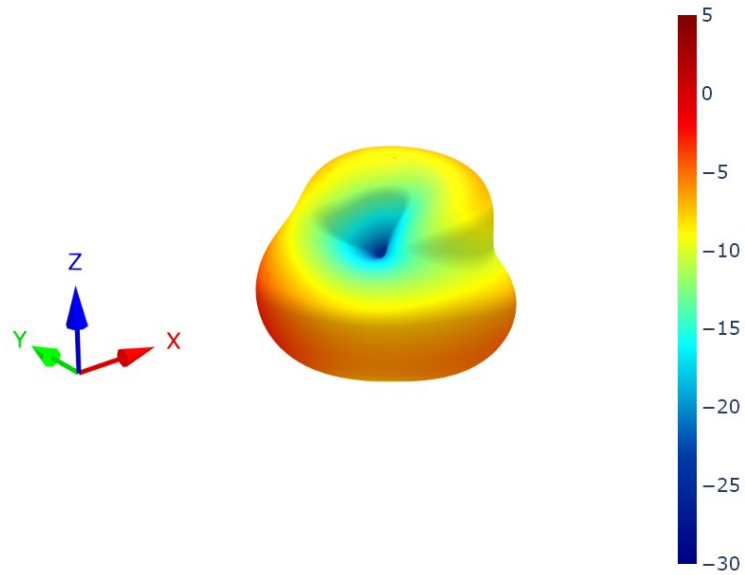

7.10 15x9cm Ground Plane Bent Patterns at 750 MHz

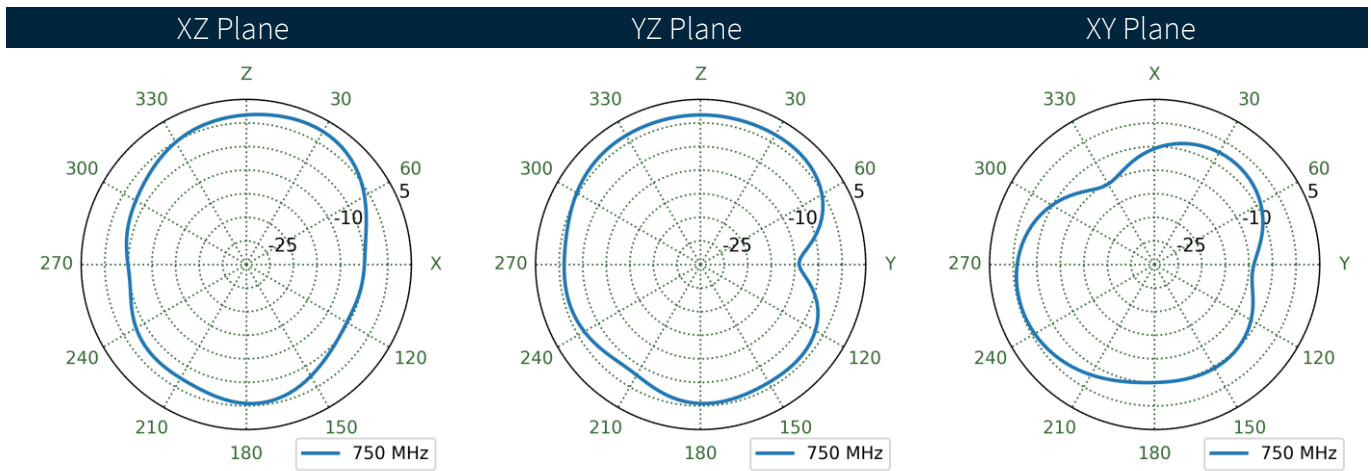
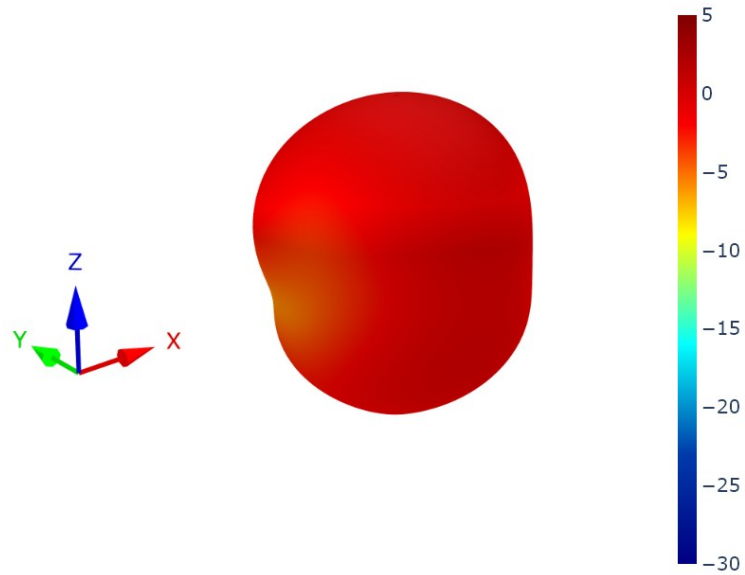

7.11 15x9cm Ground Plane Straight Patterns at 750 MHz

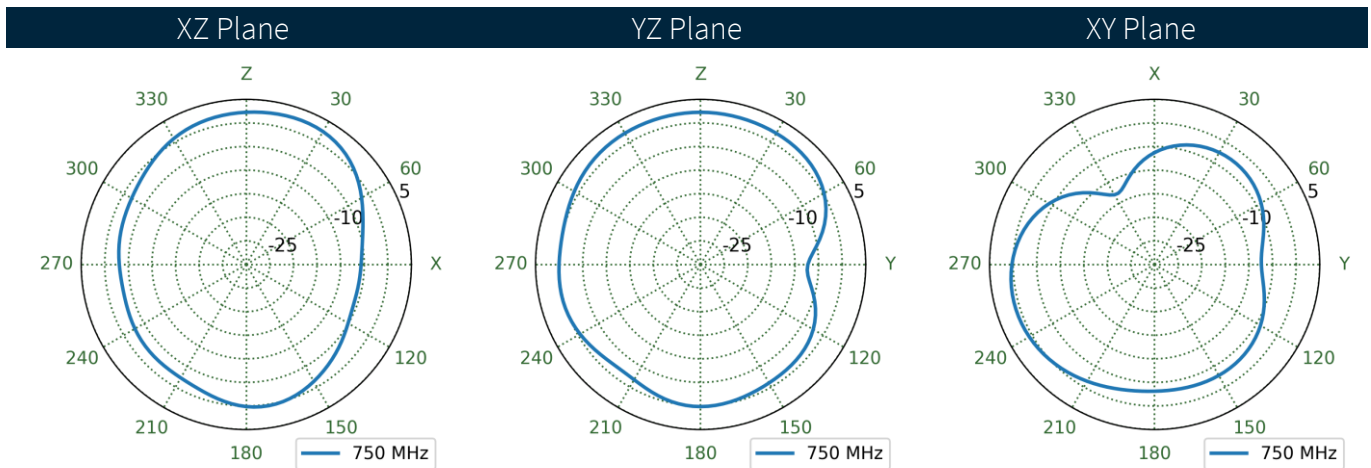
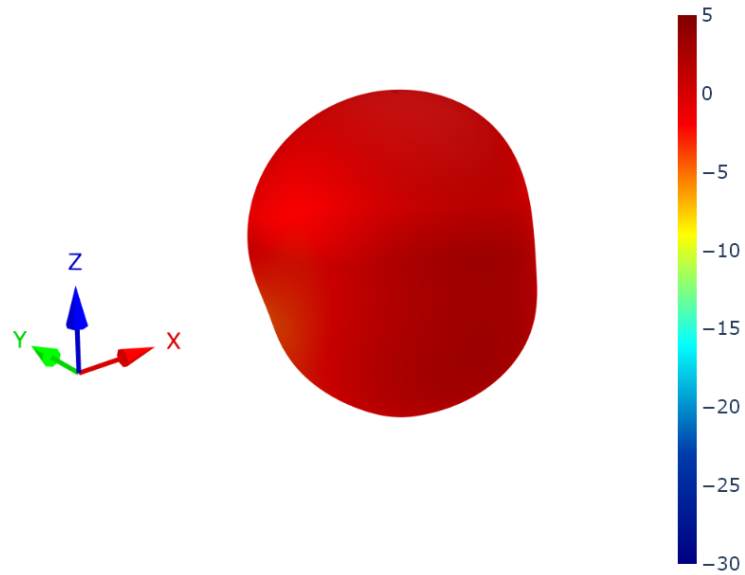

7.12 30x30cm Ground Plane (Edge) Bent Patterns at 750 MHz

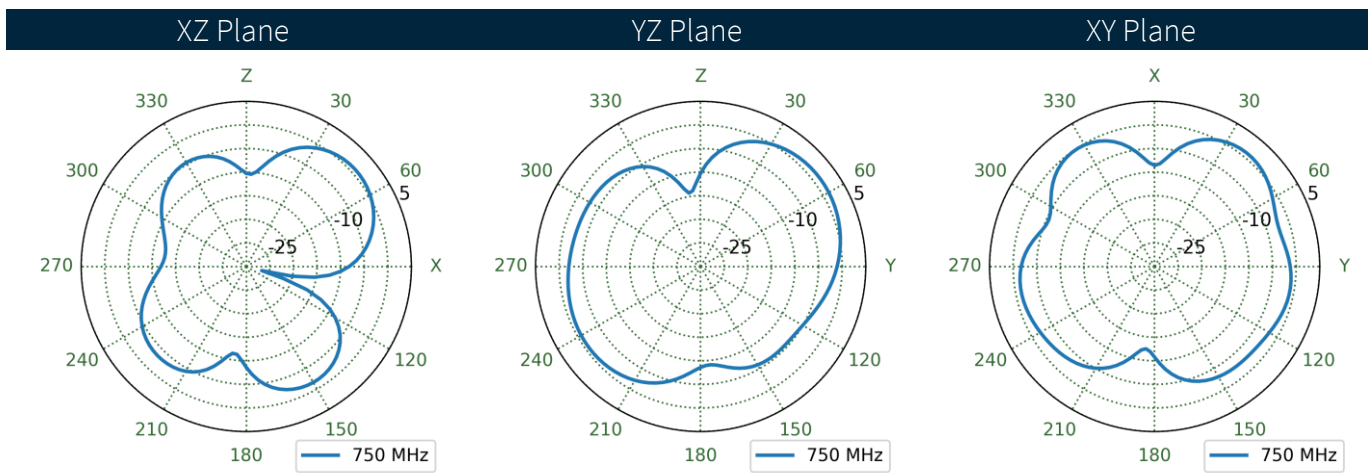
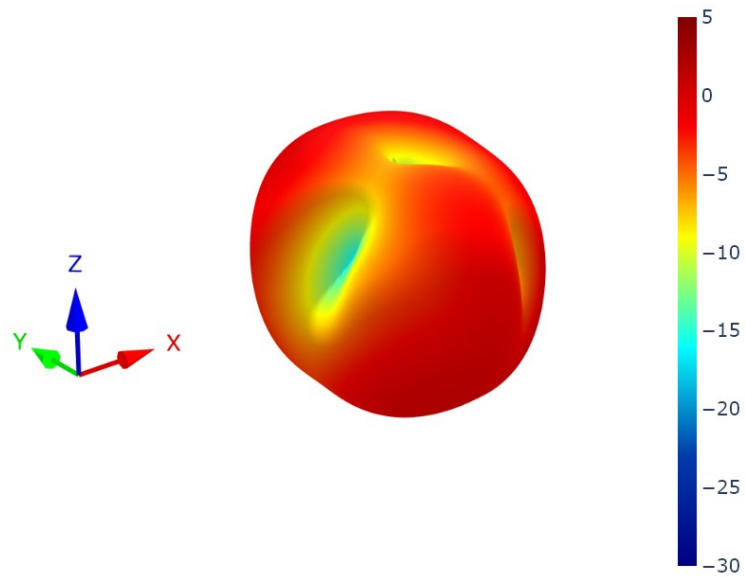



7.13 30x30cm Ground Plane (Edge) Straight Patterns at 750 MHz

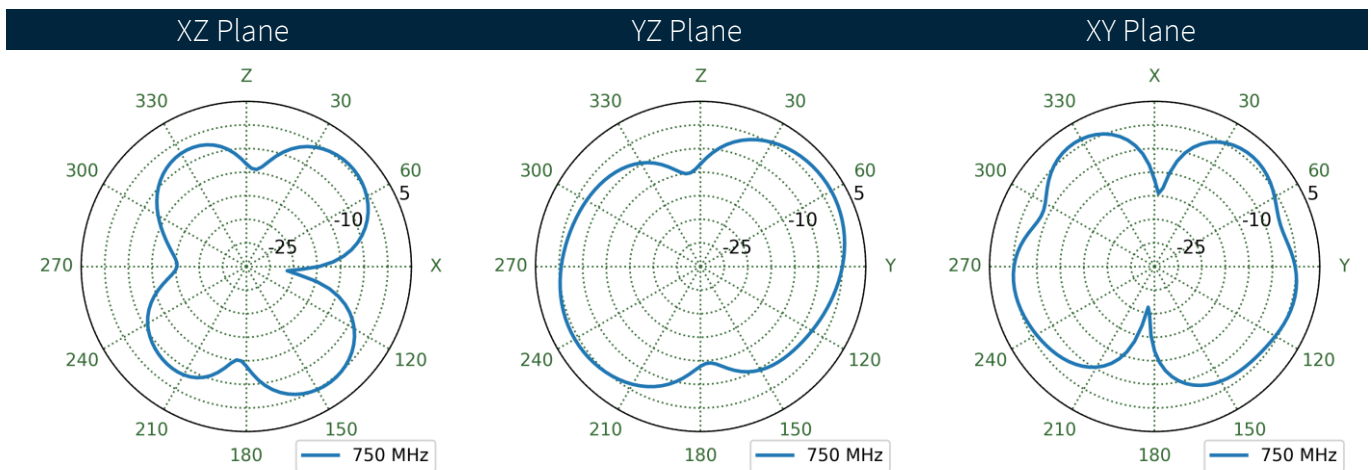
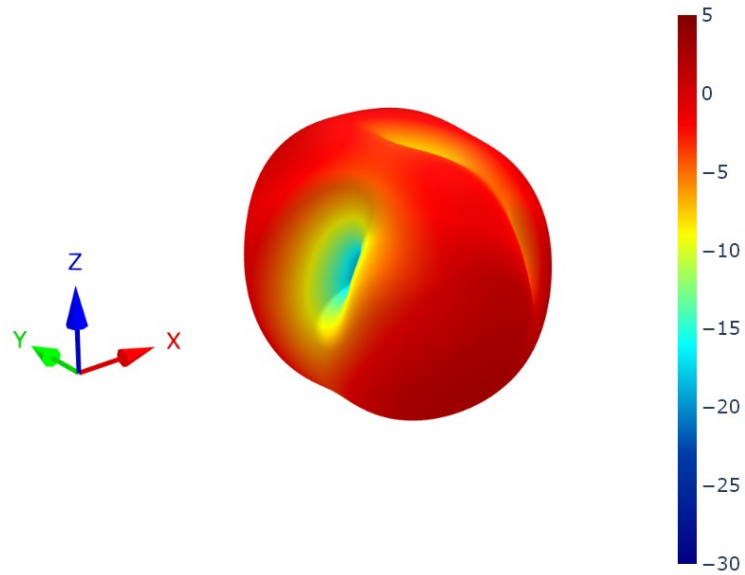

7.14 30x30cm Ground Plane Bent Patterns at 750 MHz

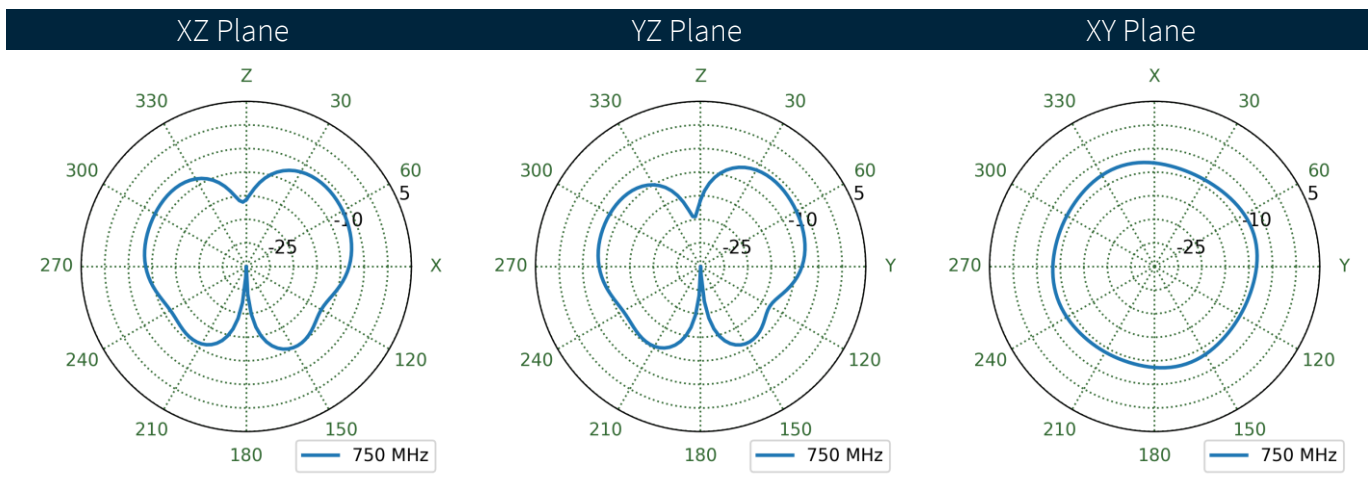
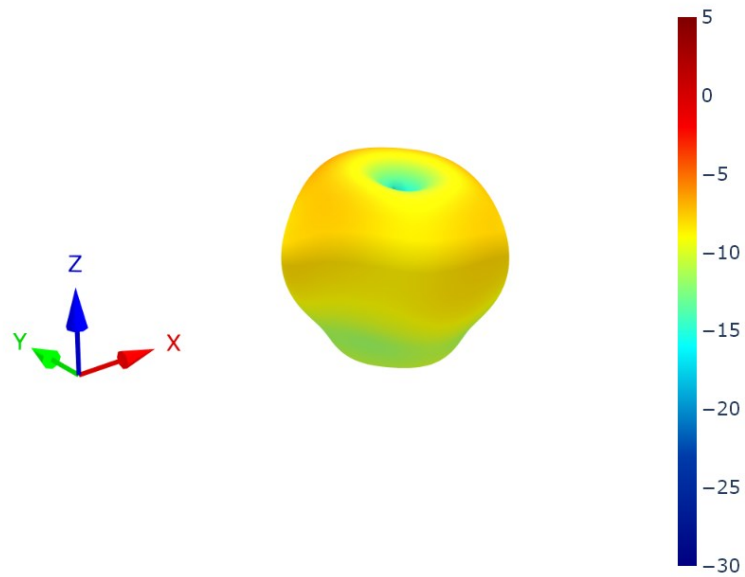

7.15 30x30cm Ground Plane Straight Patterns at 750 MHz

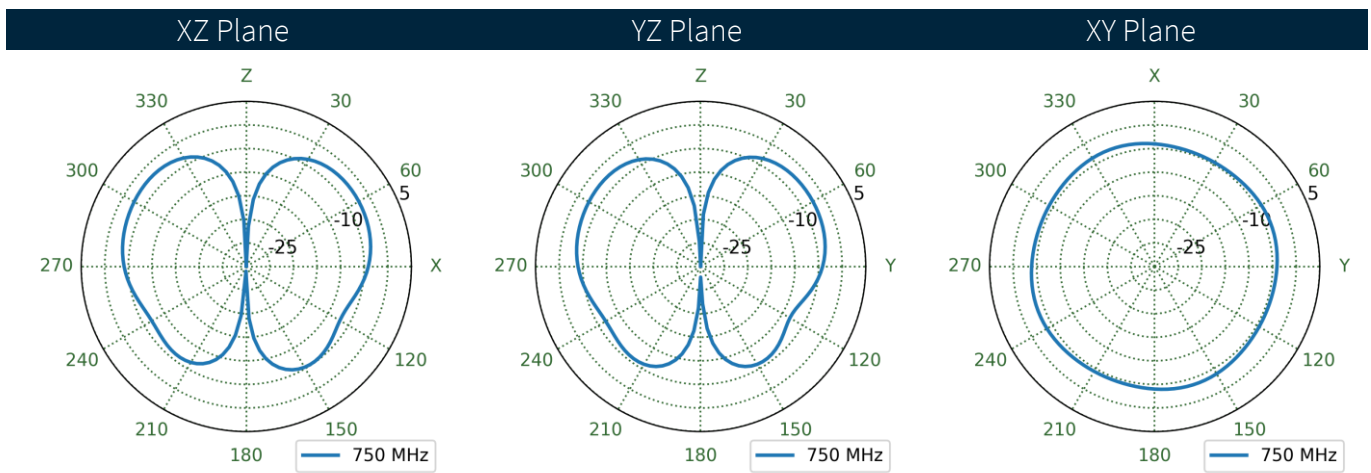
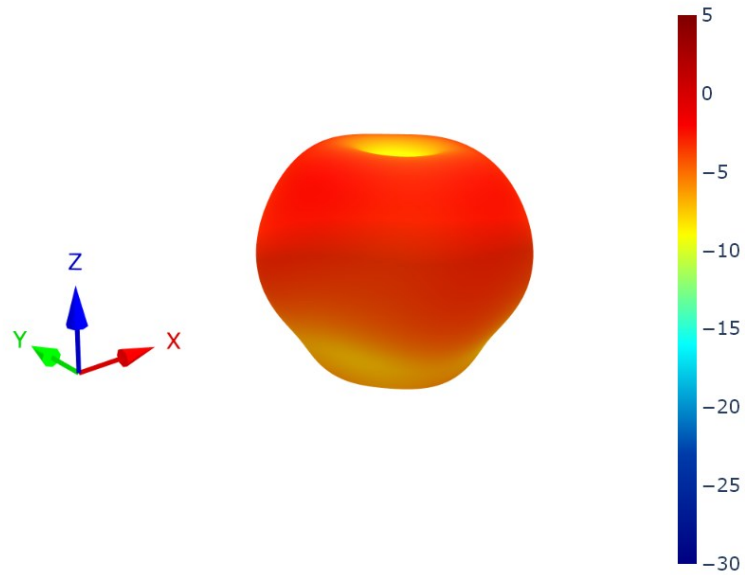

7.16 Free Space Bent Patterns at 750 MHz

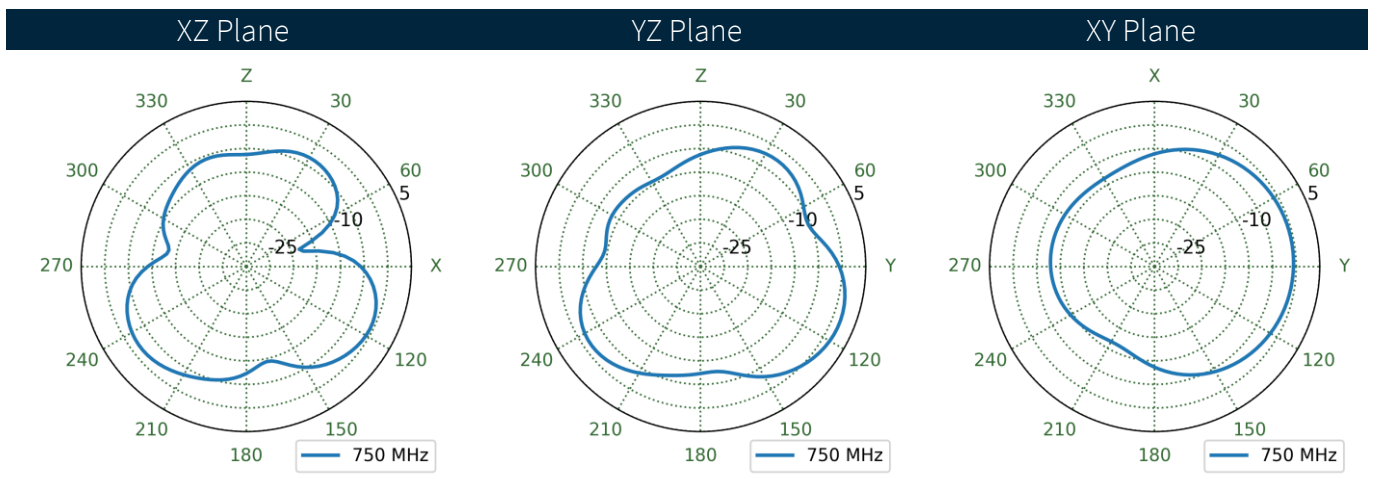
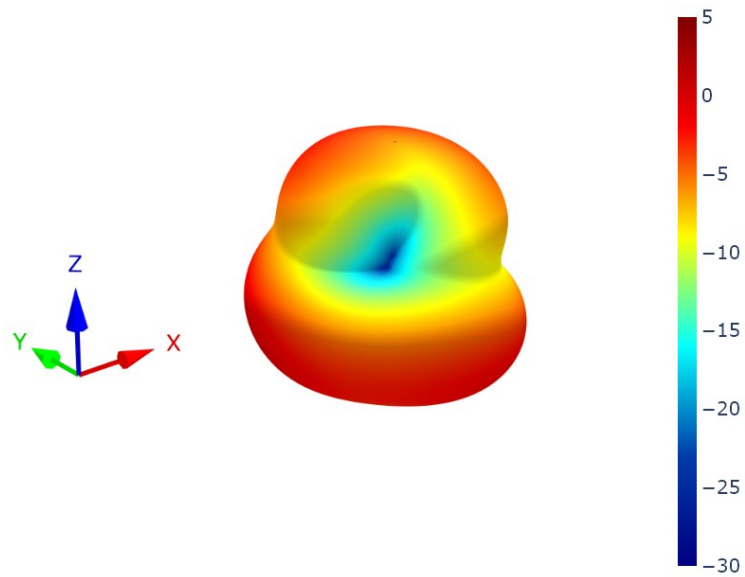

7.17 Free Space Straight Patterns at 750 MHz

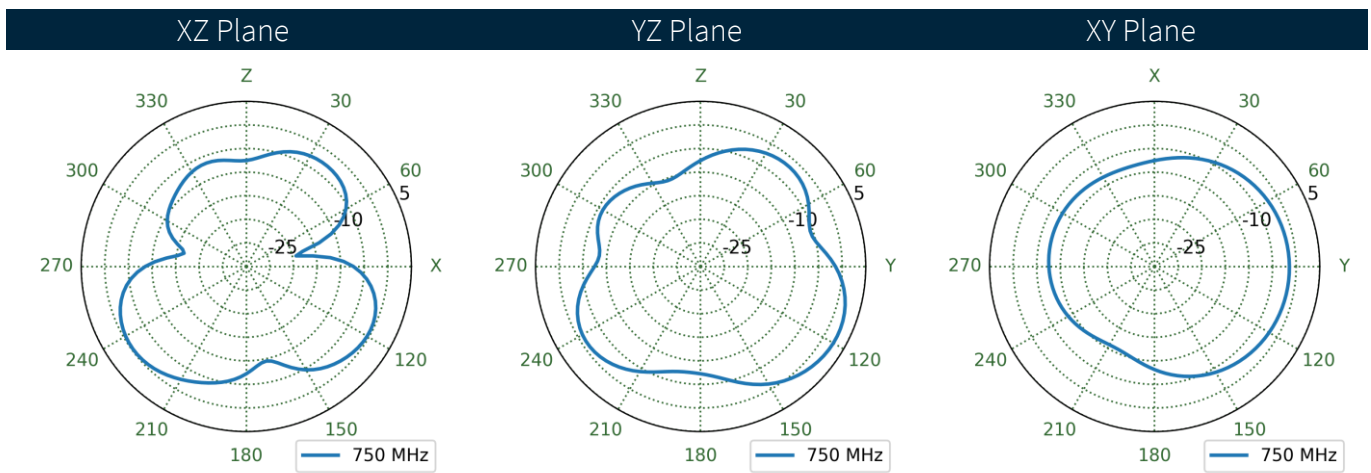
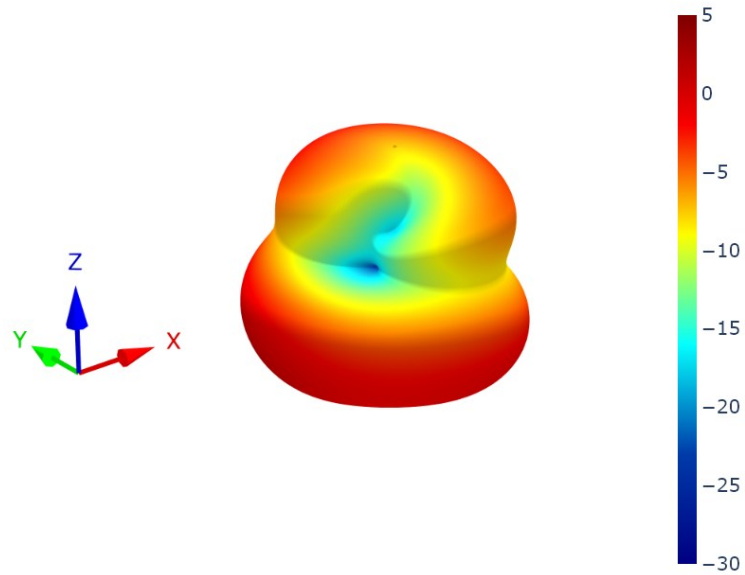

7.18 15x9cm Ground Plane Bent Patterns at 890 MHz

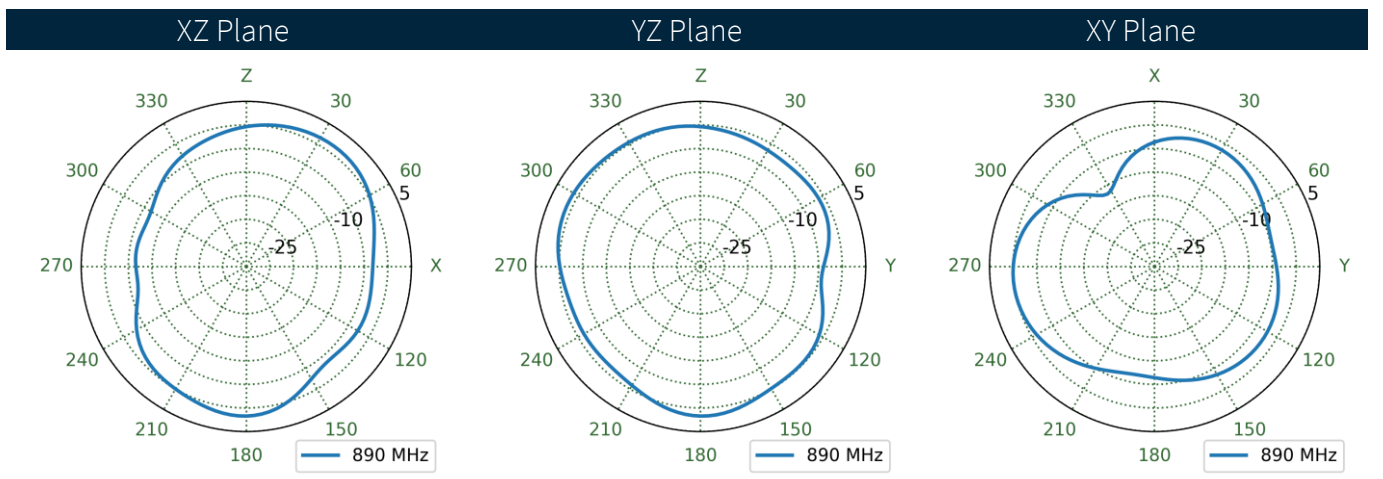
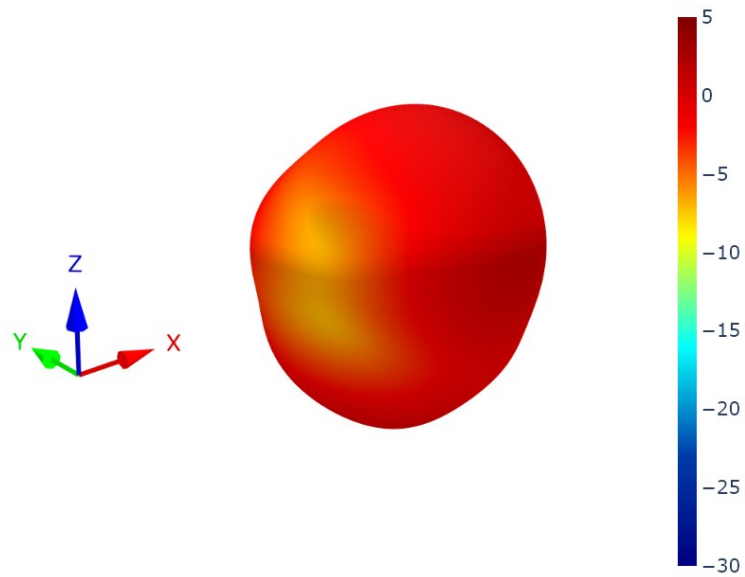

7.19 15x9cm Ground Plane Straight Patterns at 890 MHz

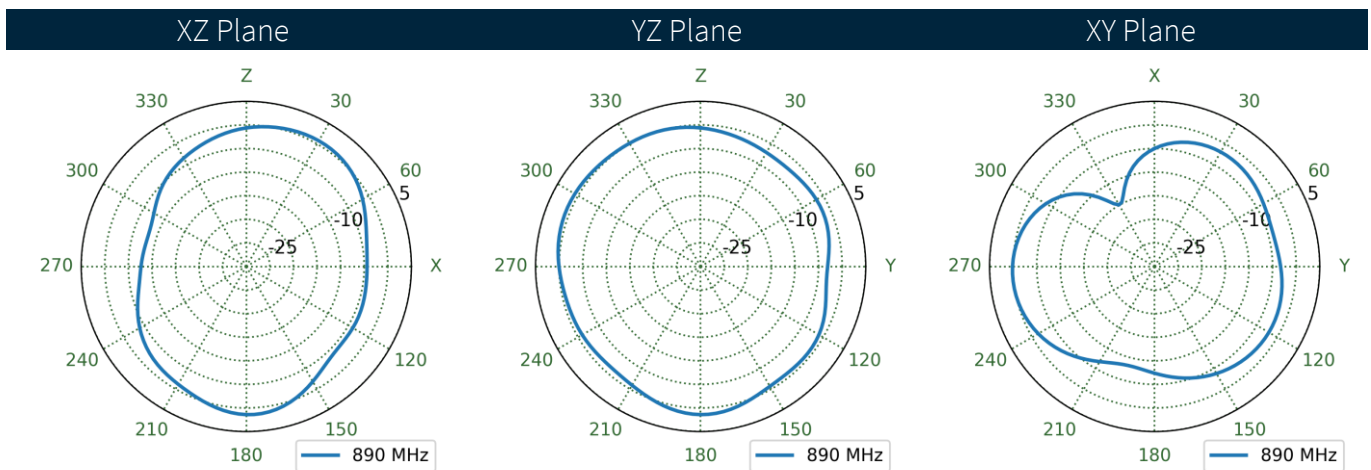
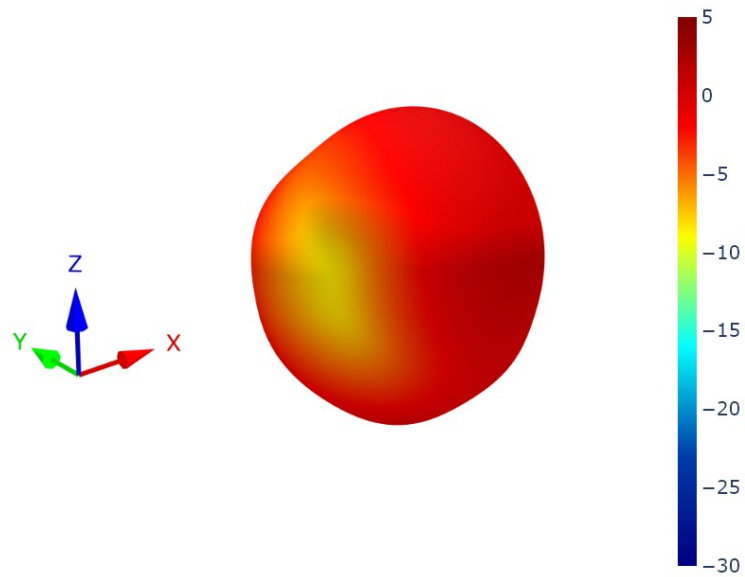

7.20 30x30cm Ground Plane (Edge) Bent Patterns at 890 MHz

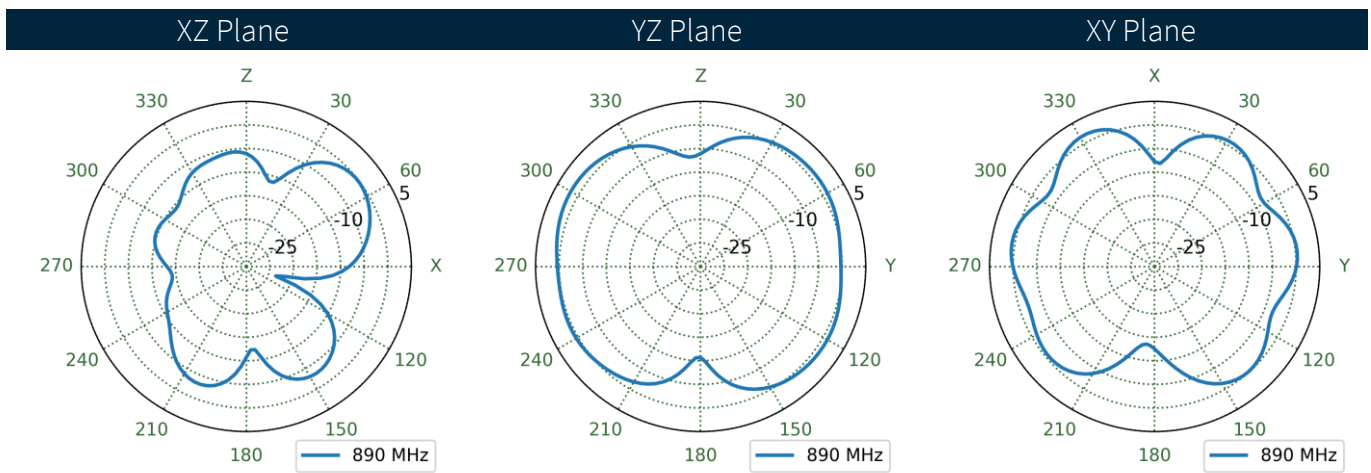
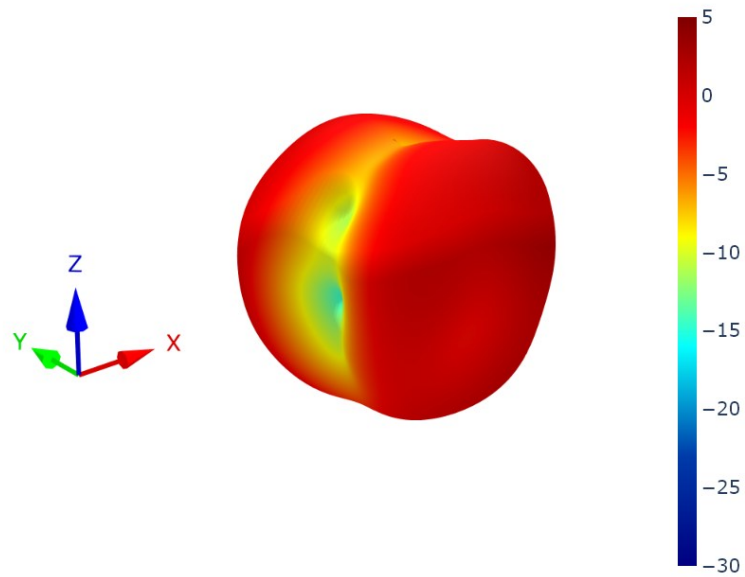



7.21 30x30cm Ground Plane (Edge) Straight Patterns at 890 MHz

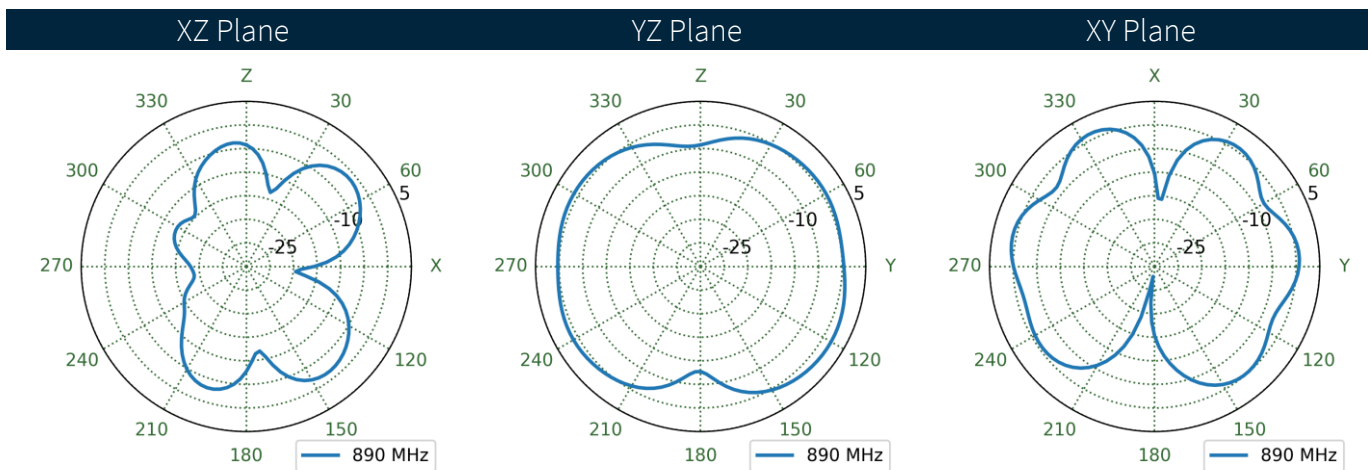
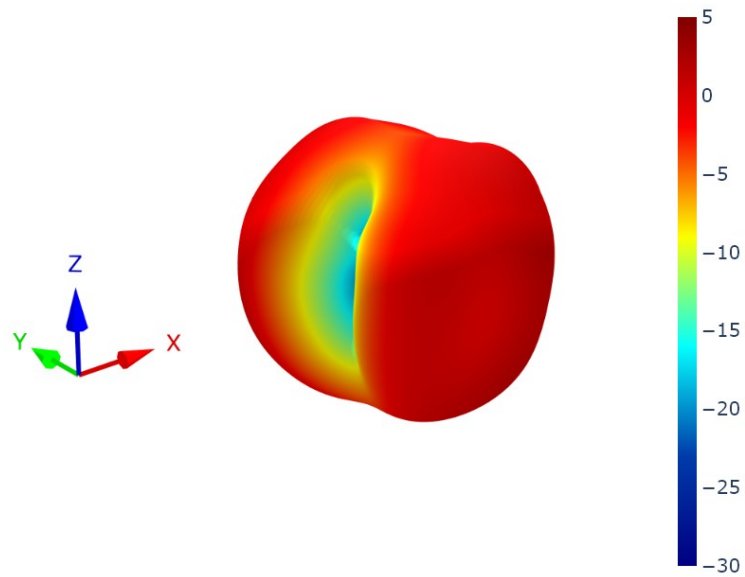

7.22 30x30cm Ground Plane Bent Patterns at 890 MHz

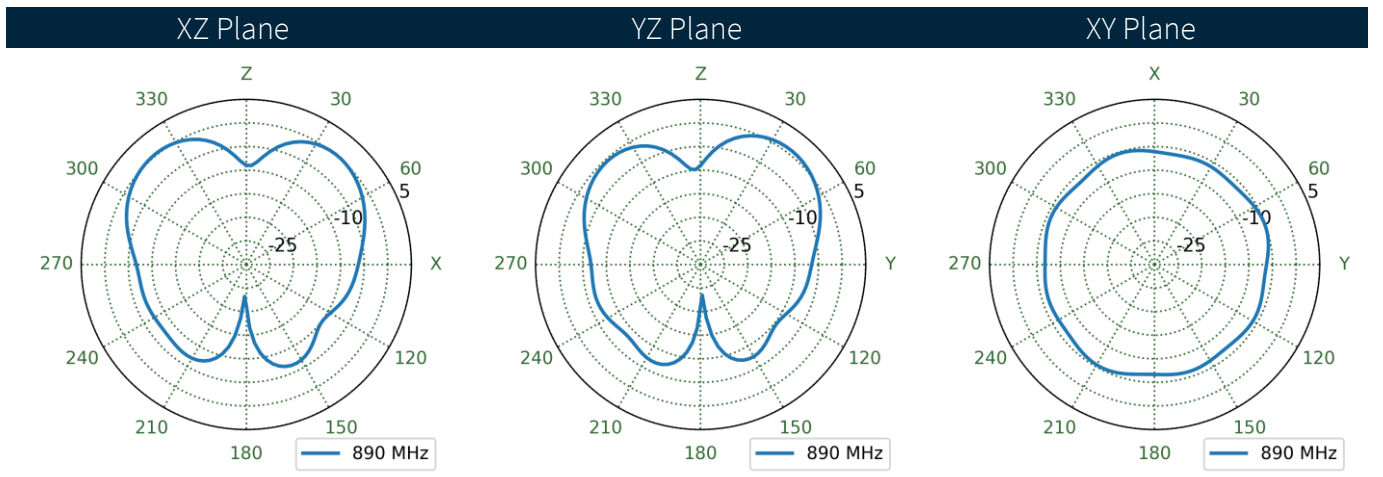
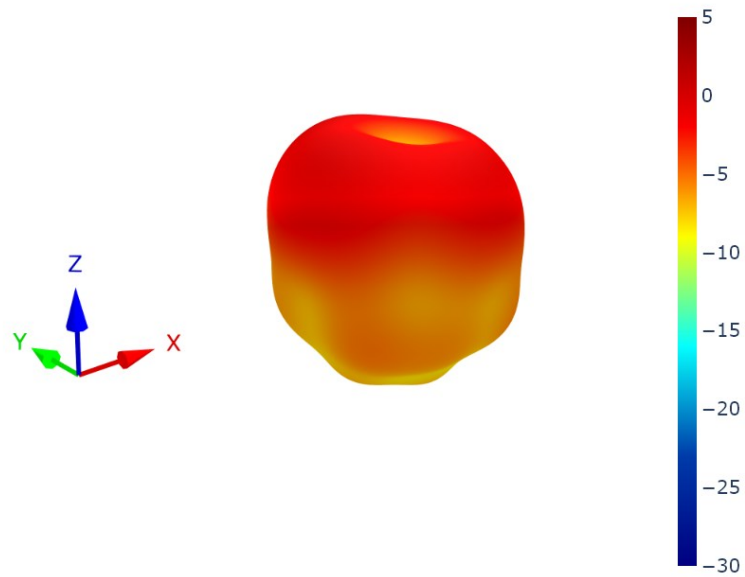

7.23 30x30cm Ground Plane Straight Patterns at 890 MHz

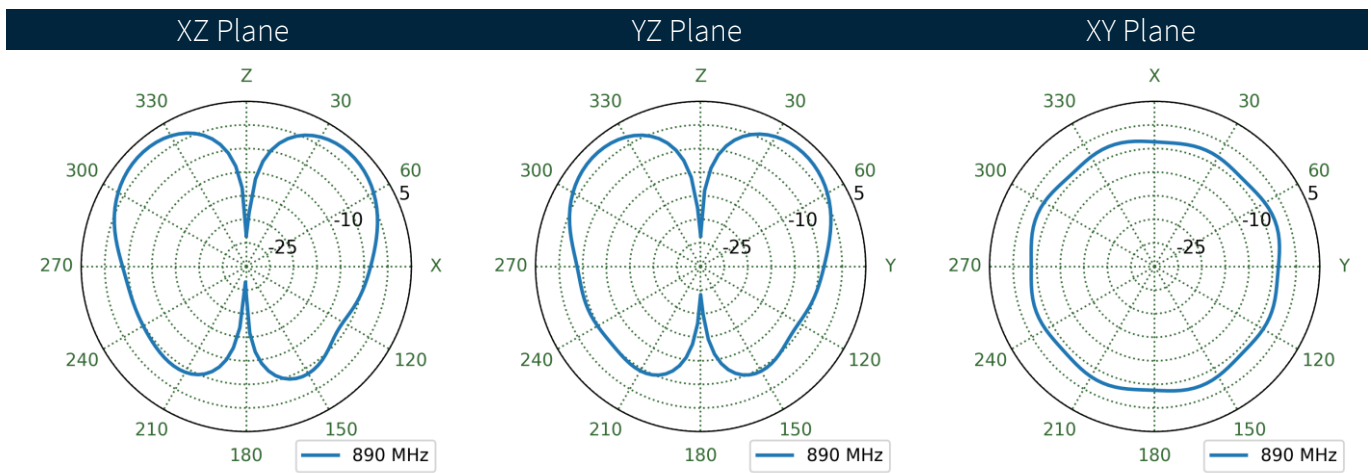
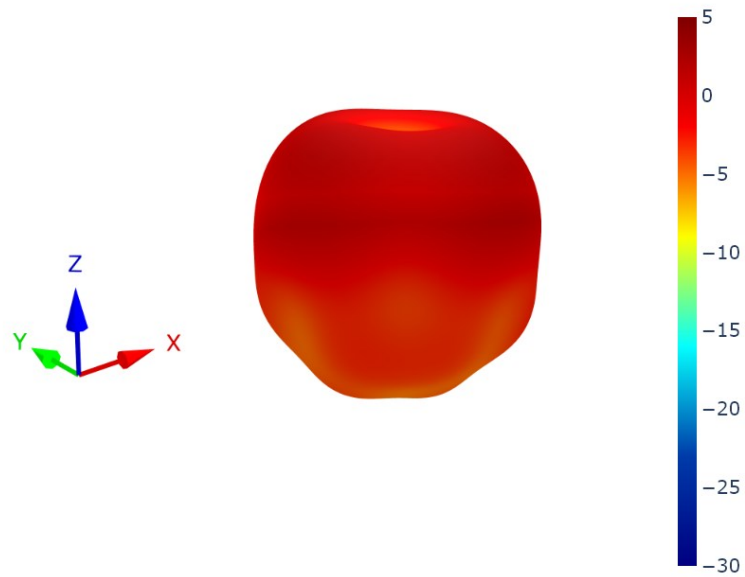

7.24 Free Space Bent Patterns at 890 MHz

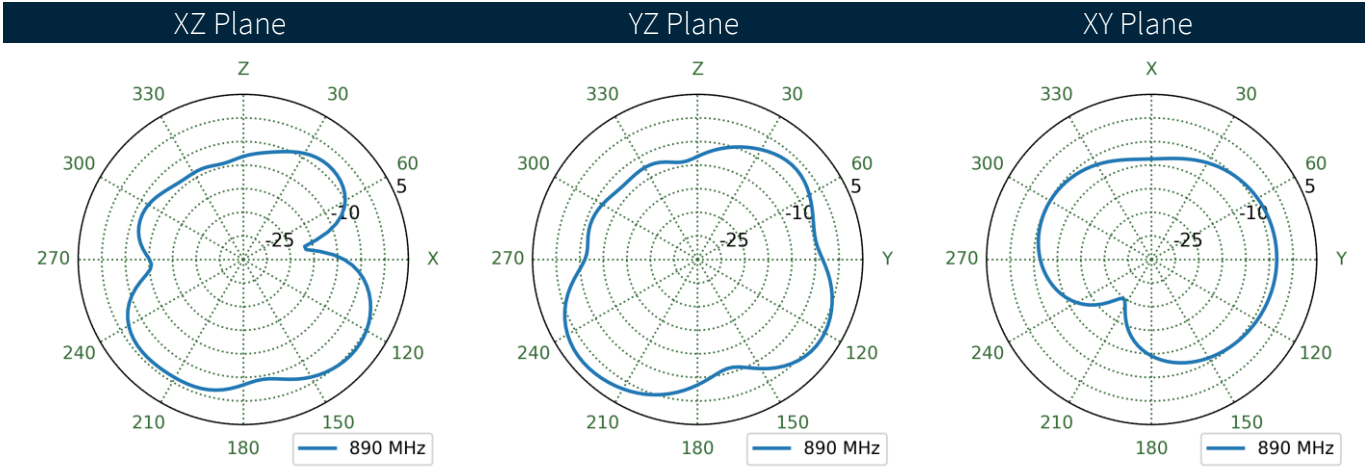
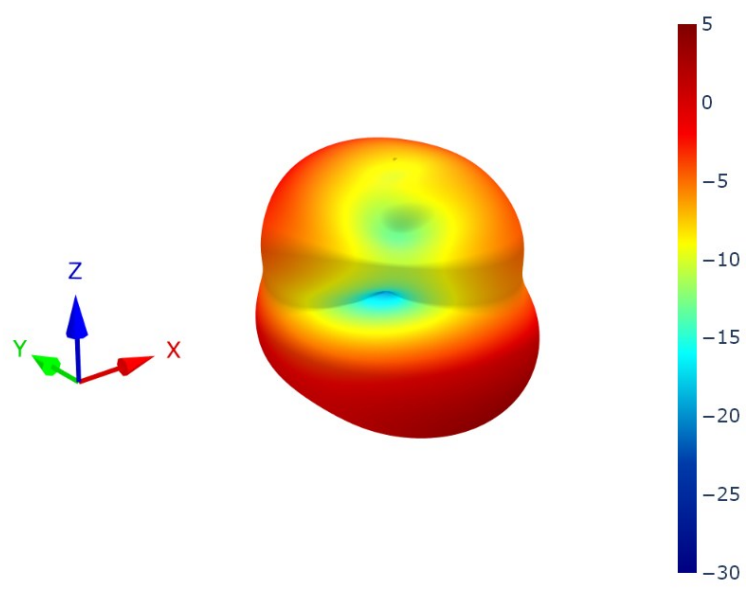

7.25 Free Space Straight Patterns at 890 MHz

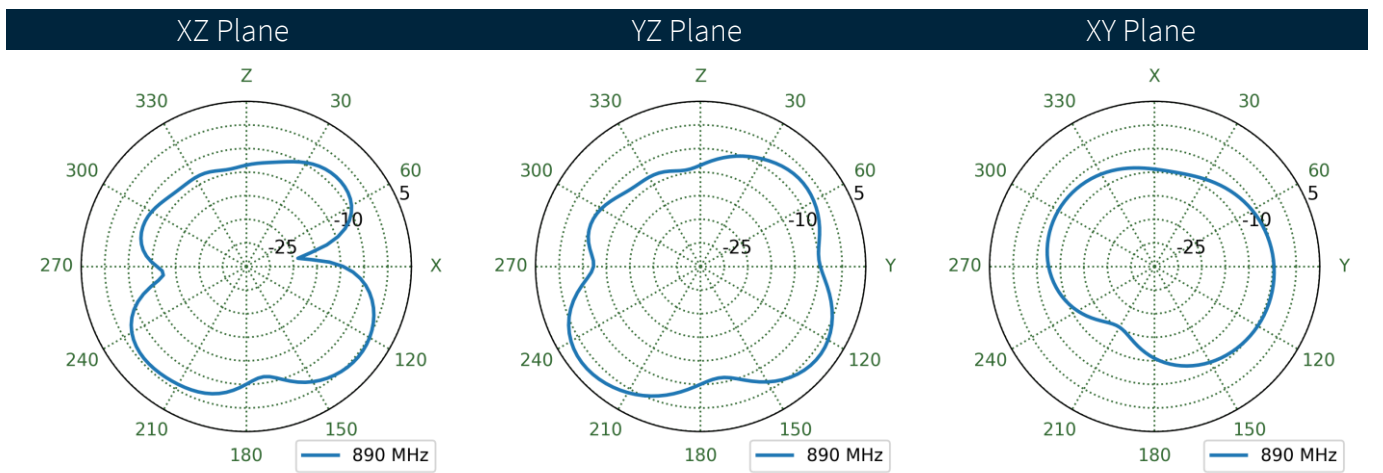
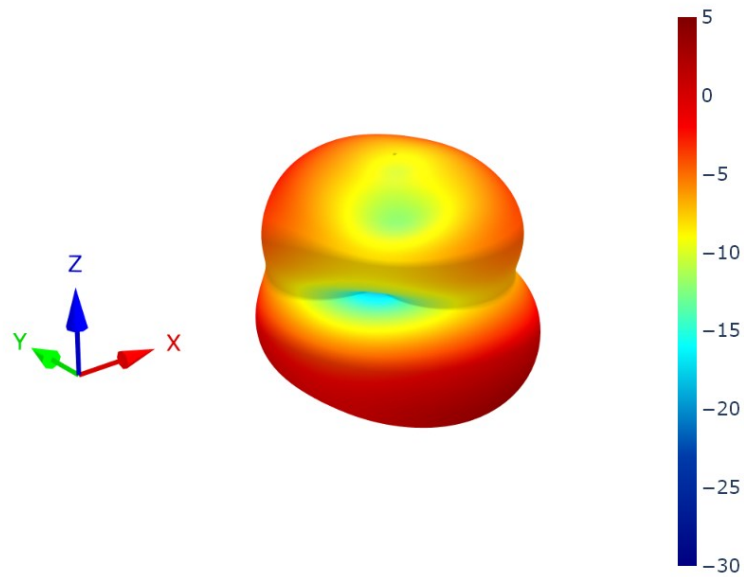

7.26 15x9cm Ground Plane Bent Patterns at 1470 MHz

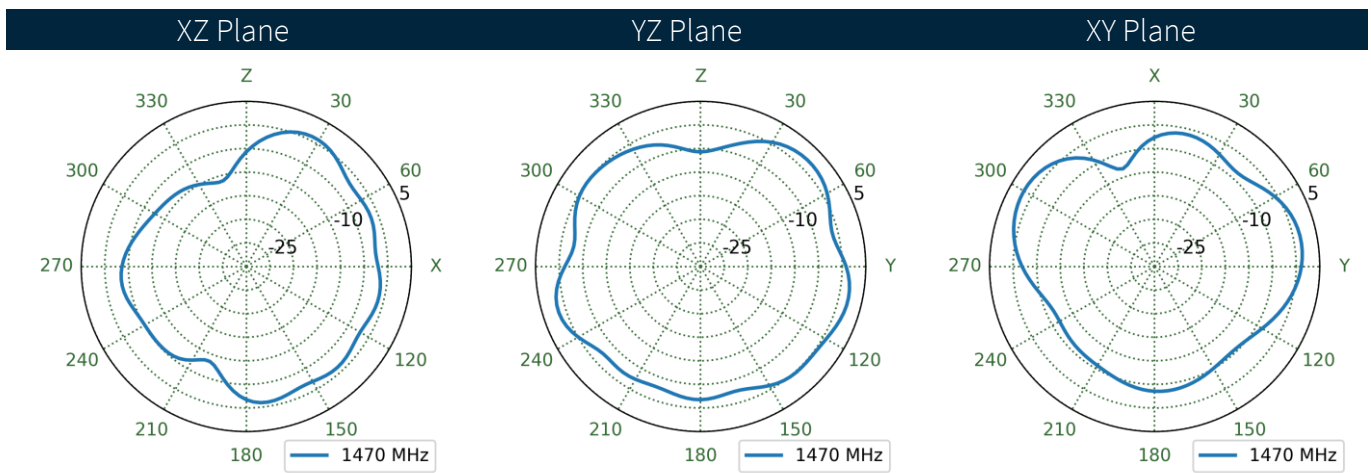
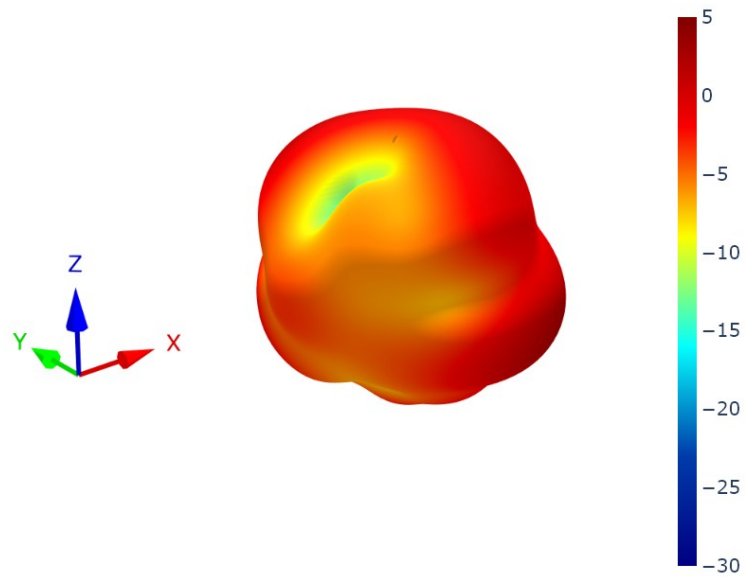

7.27 15x9cm Ground Plane Straight Patterns at 1470 MHz

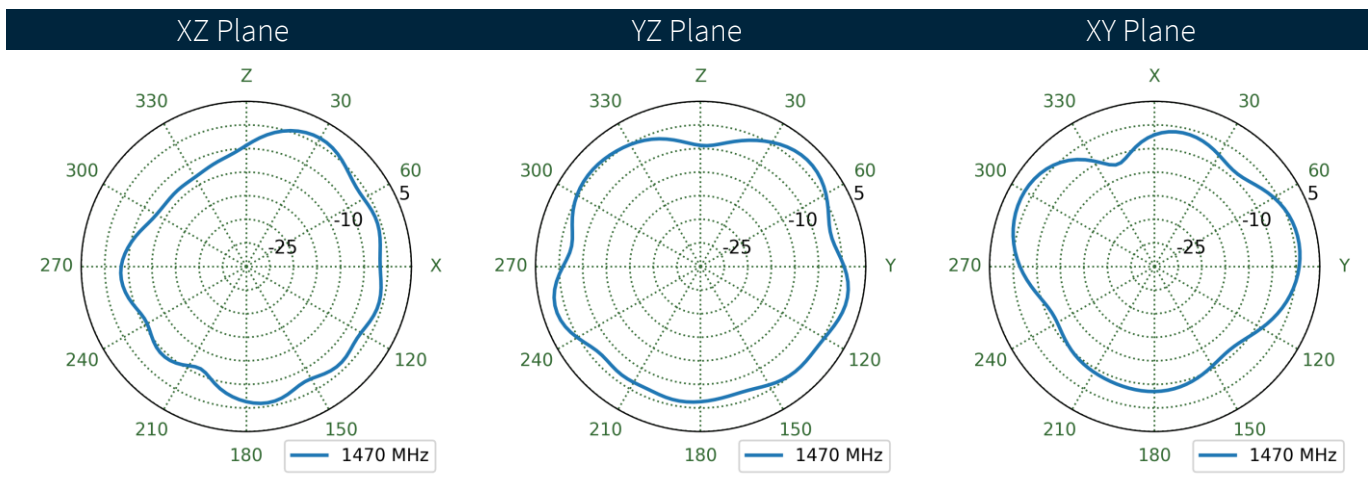
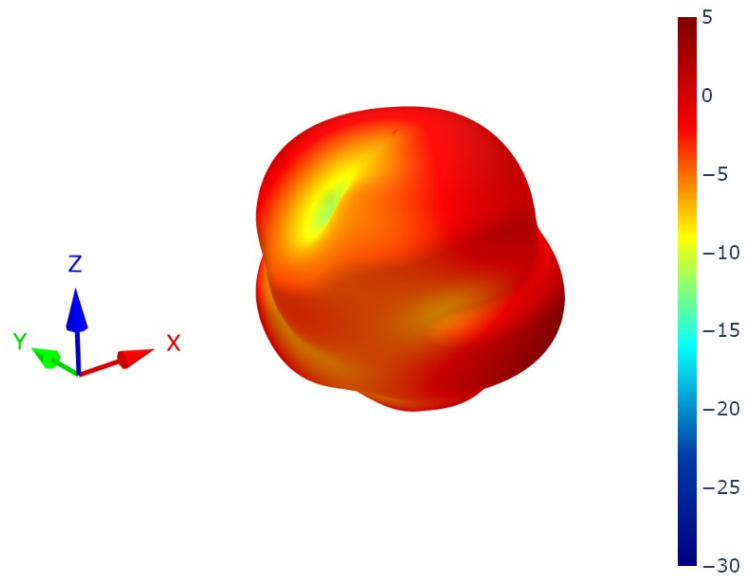

7.28 30x30cm Ground Plane (Edge) Bent Patterns at 1470 MHz

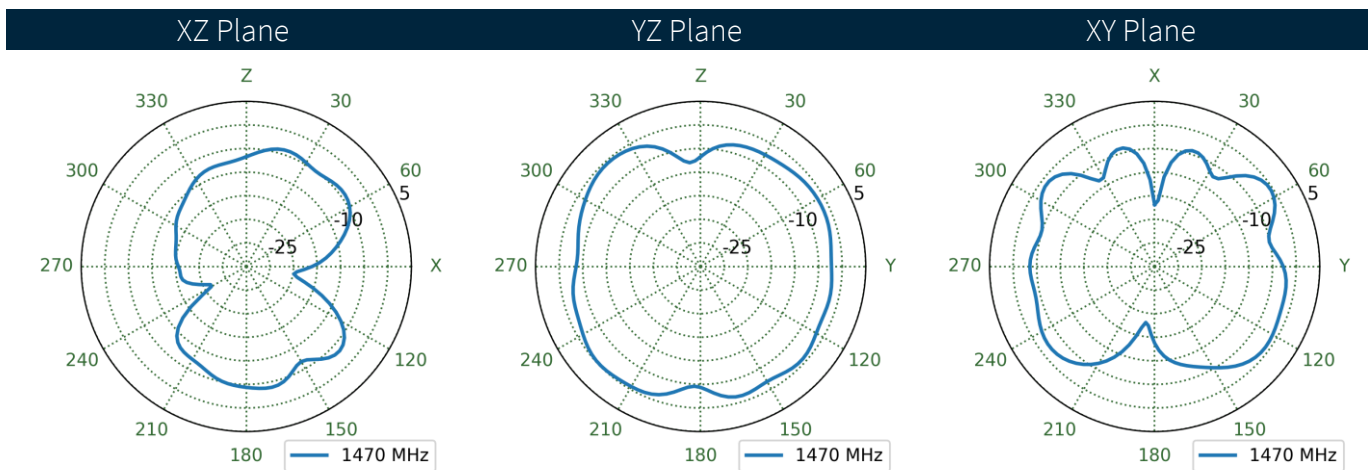
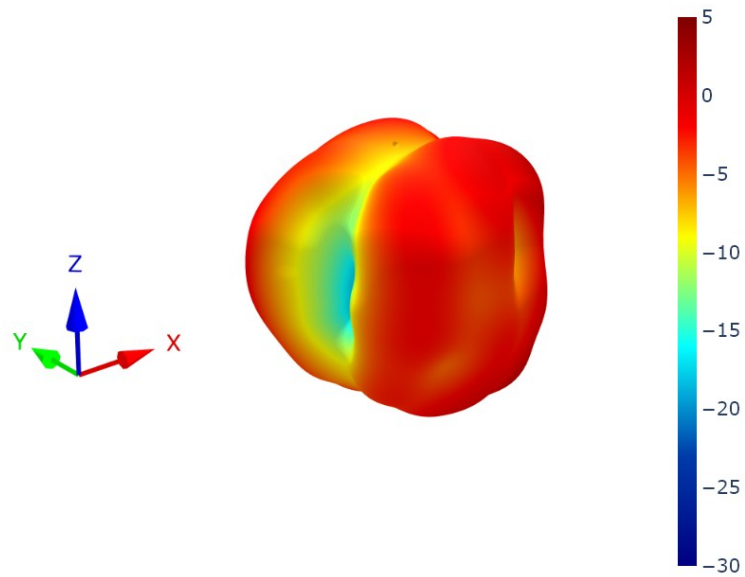



7.29 30x30cm Ground Plane (Edge) Straight Patterns at 1470 MHz

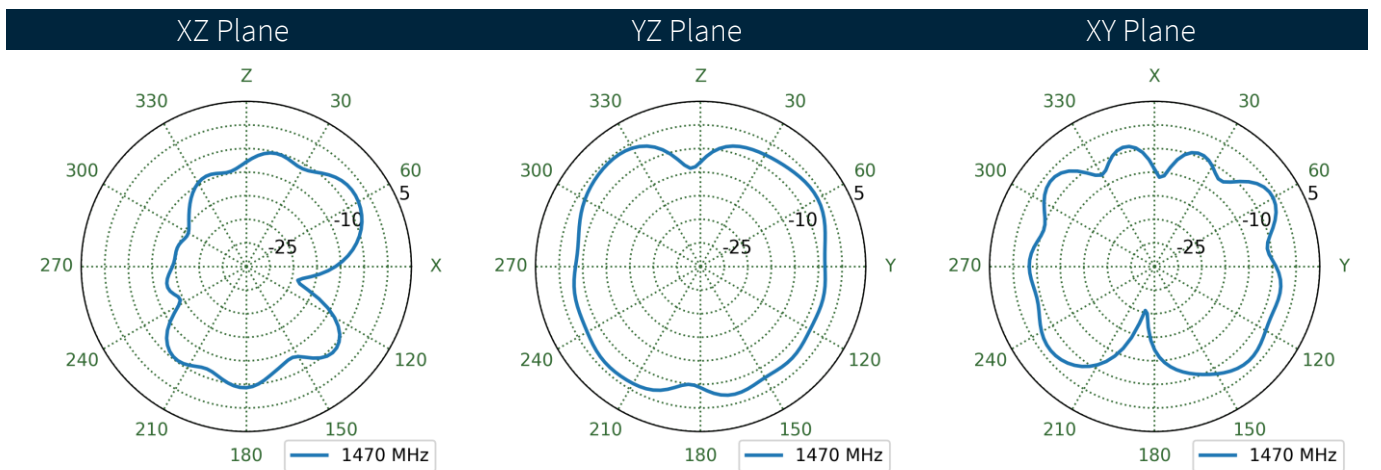
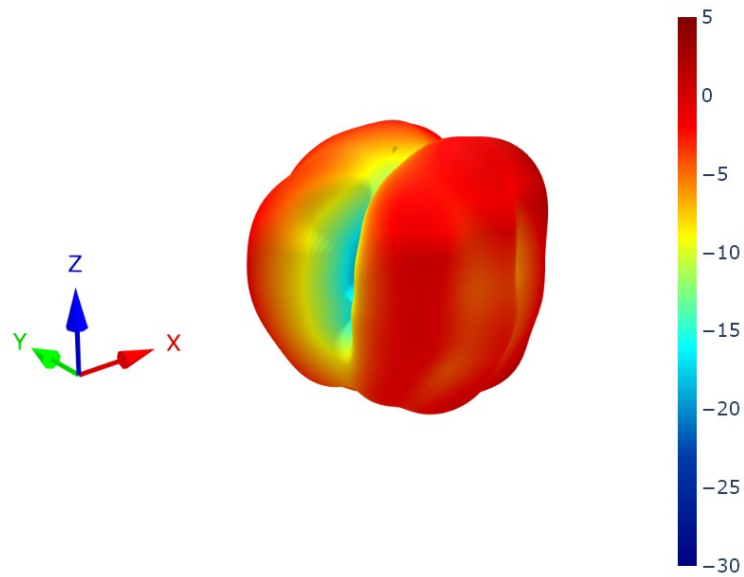

7.30 30x30cm Ground Plane Bent Patterns at 1470 MHz

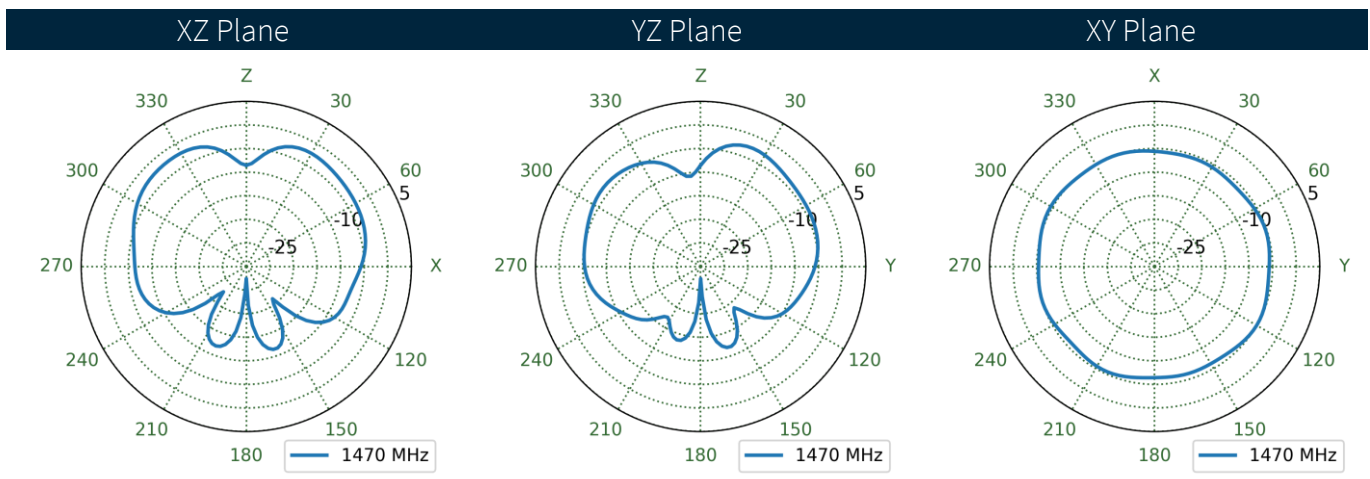
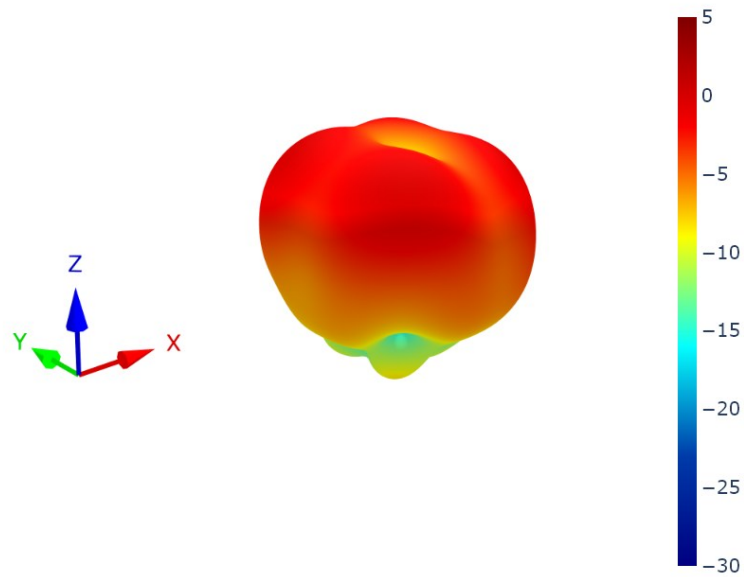

7.31 30x30cm Ground Plane Straight Patterns at 1470 MHz

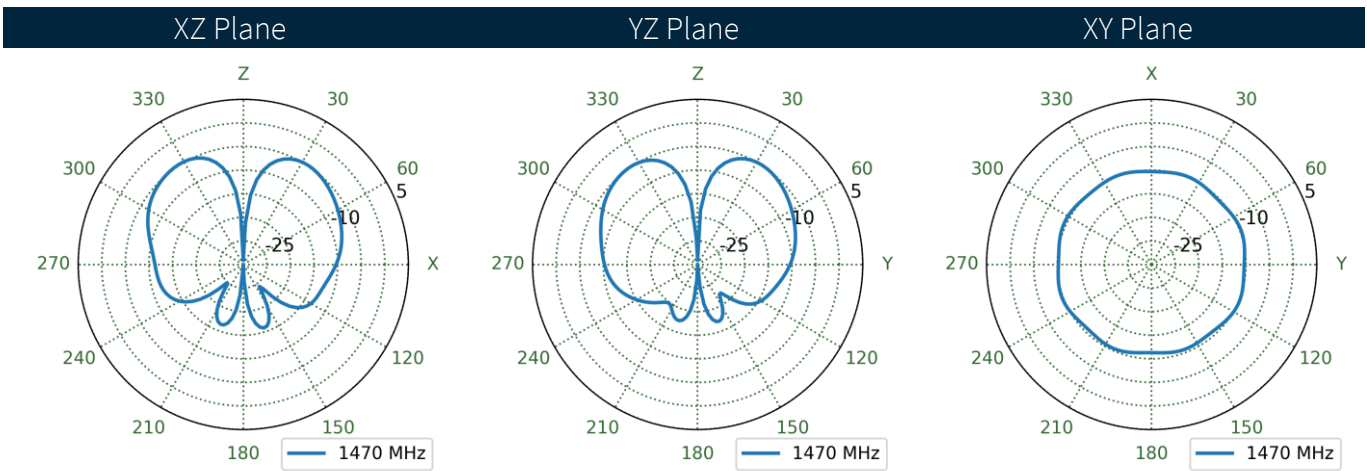
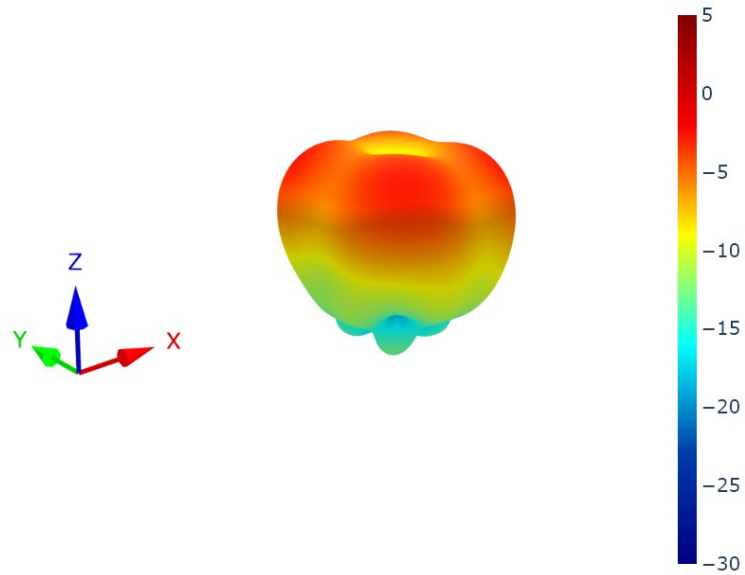

7.32 Free Space Bent Patterns at 1470 MHz

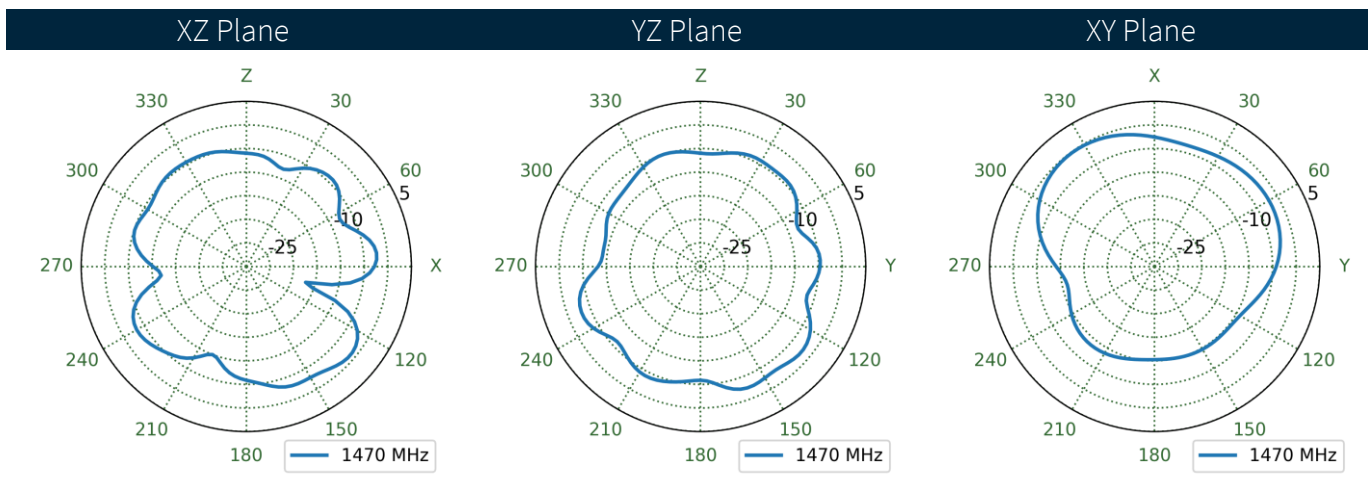
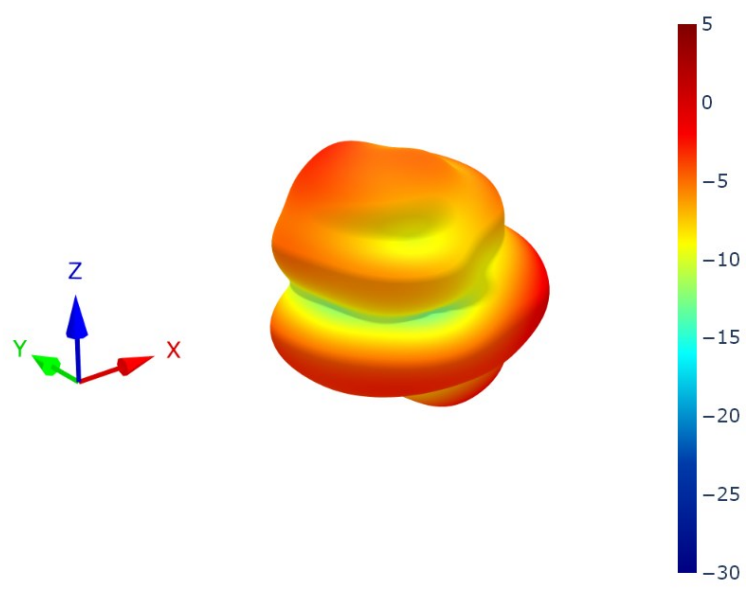

7.33 Free Space Straight Patterns at 1470 MHz

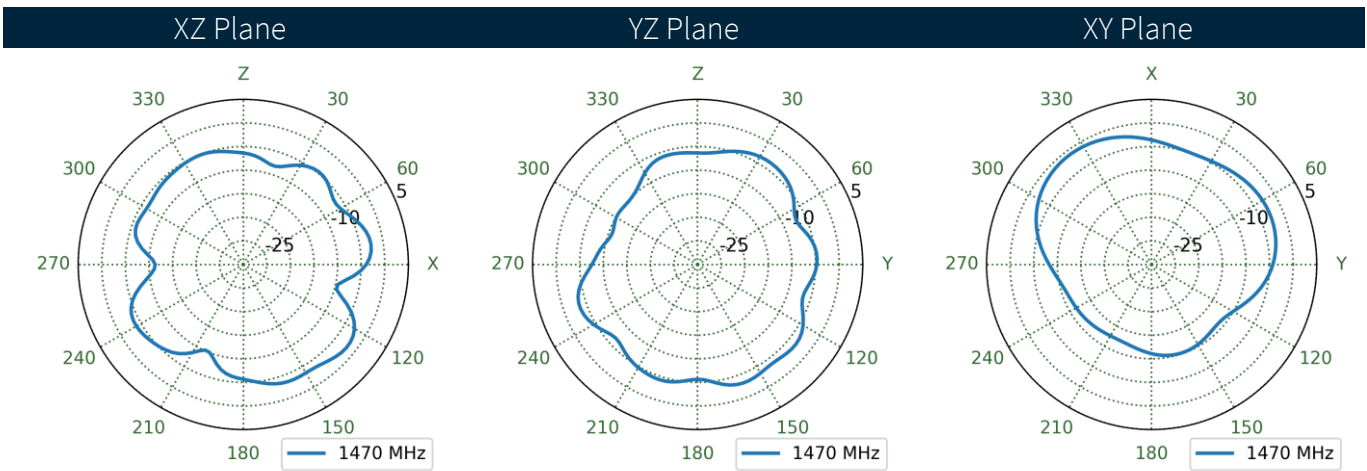
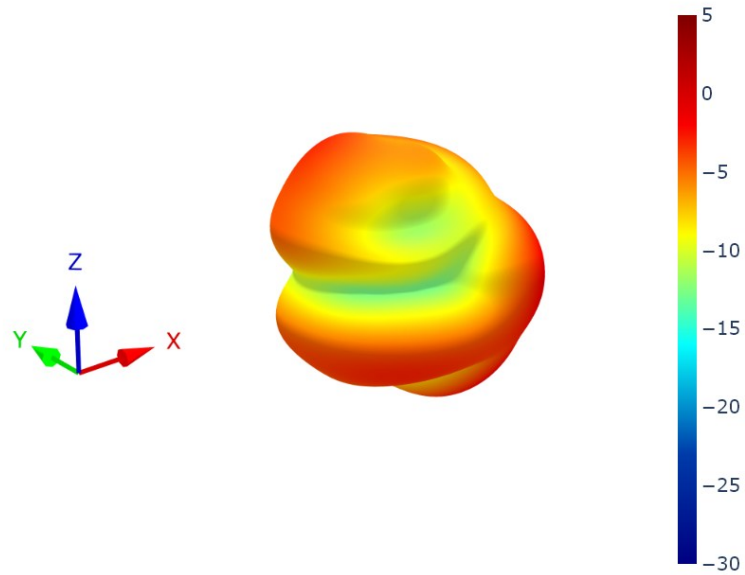

7.34 15x9cm Ground Plane Bent Patterns at 1950 MHz

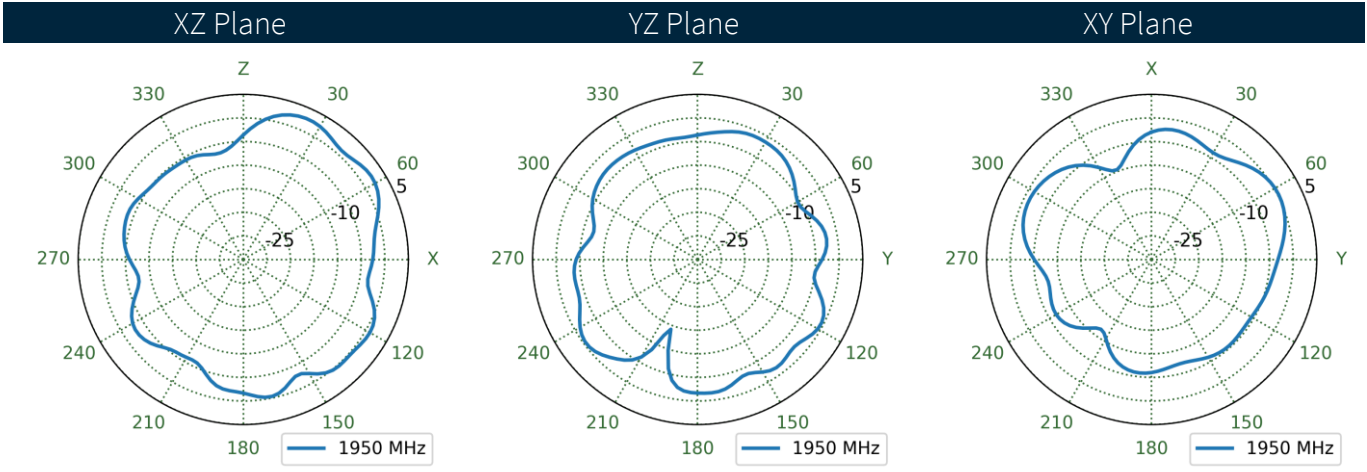
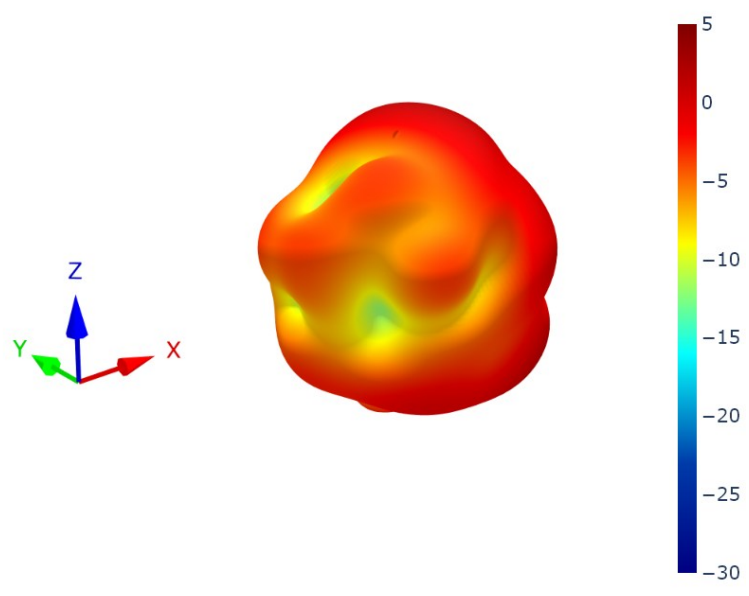

7.35 15x9cm Ground Plane Straight Patterns at 1950 MHz

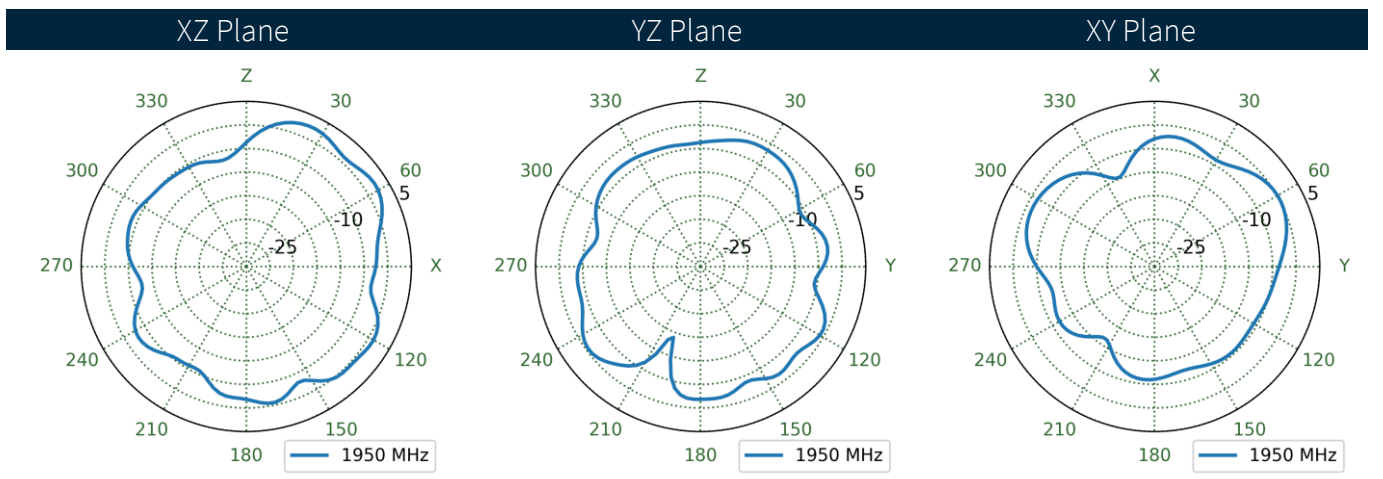
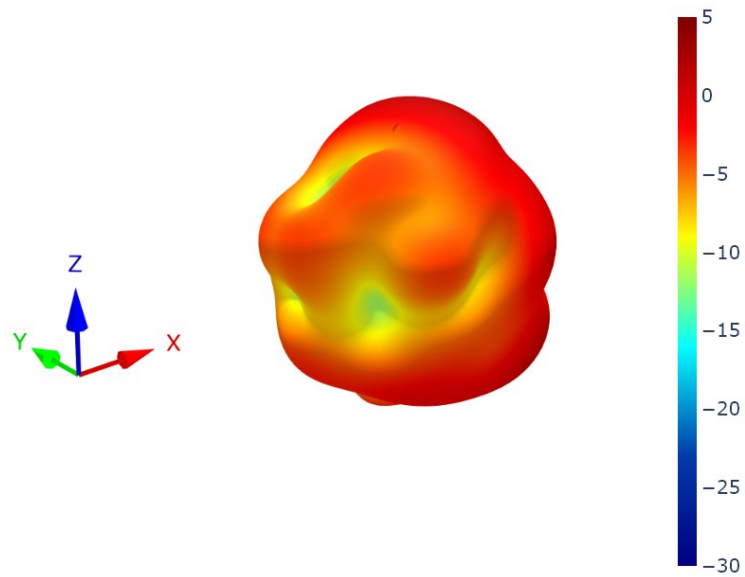

7.36 30x30cm Ground Plane (Edge) Bent Patterns at 1950 MHz

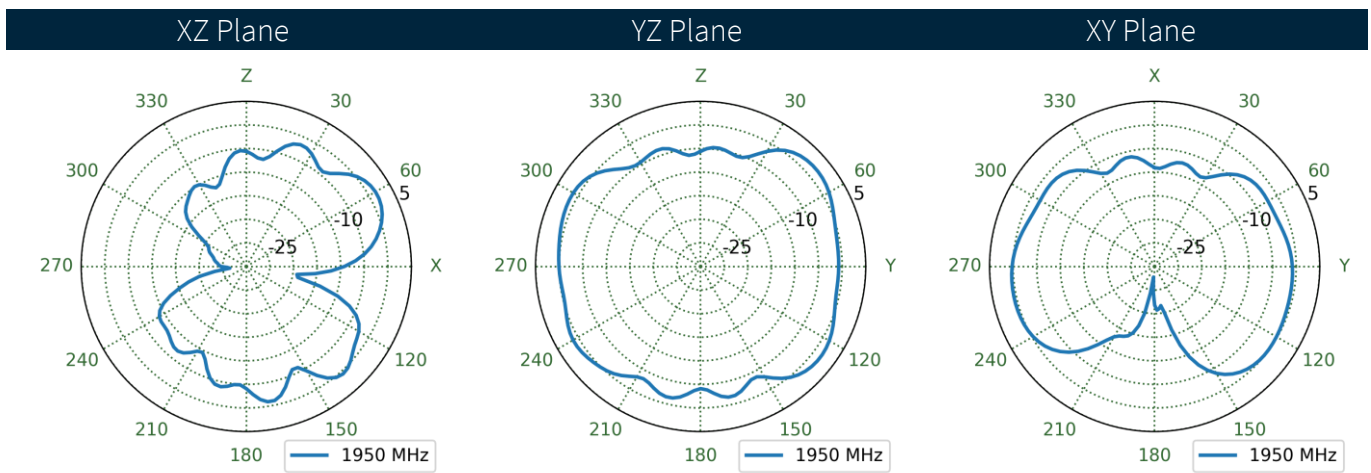
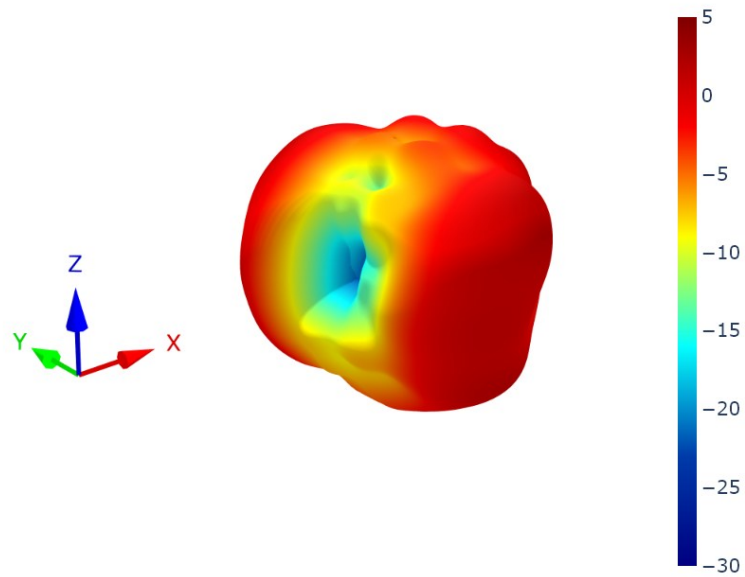



7.37 30x30cm Ground Plane (Edge) Straight Patterns at 1950 MHz

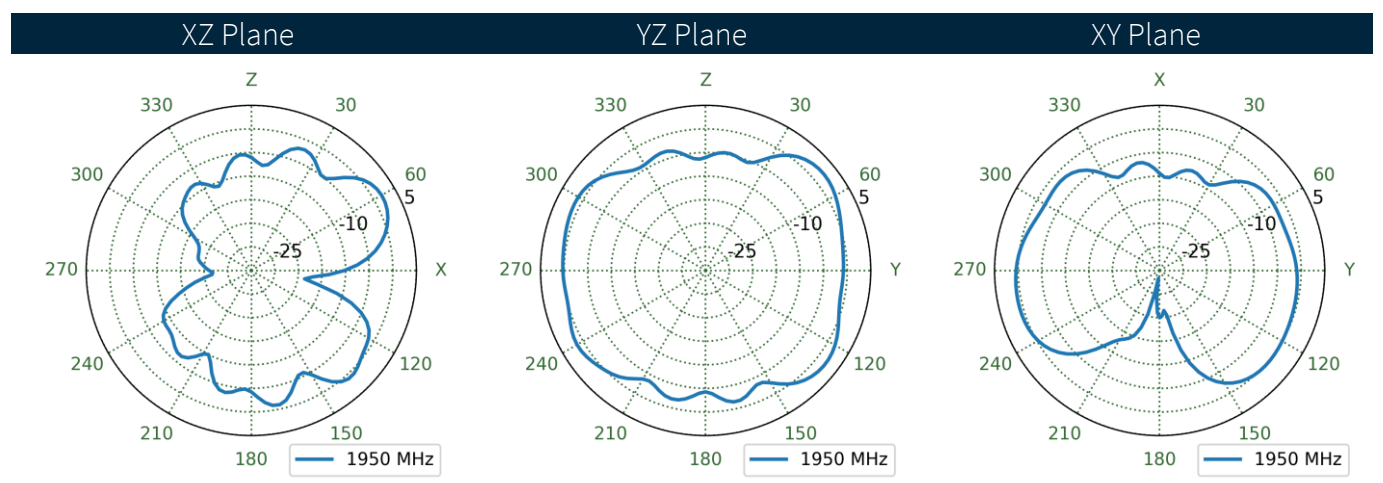
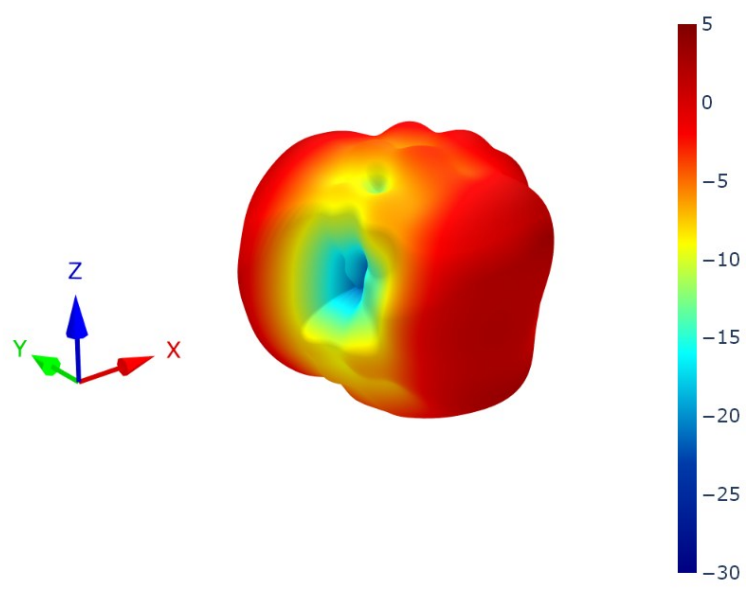

7.38 30x30cm Ground Plane Bent Patterns at 1950 MHz

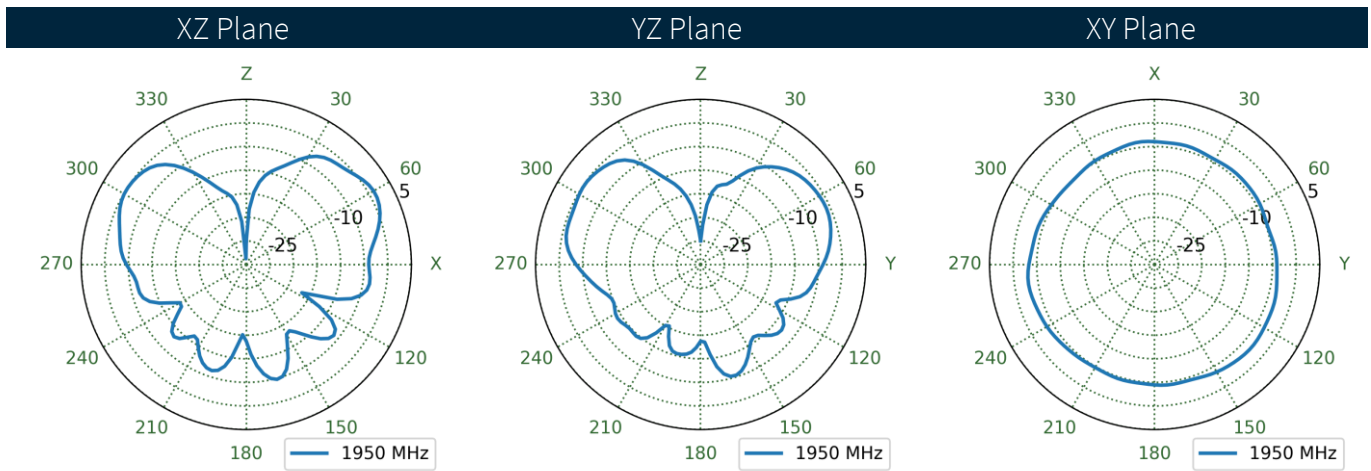
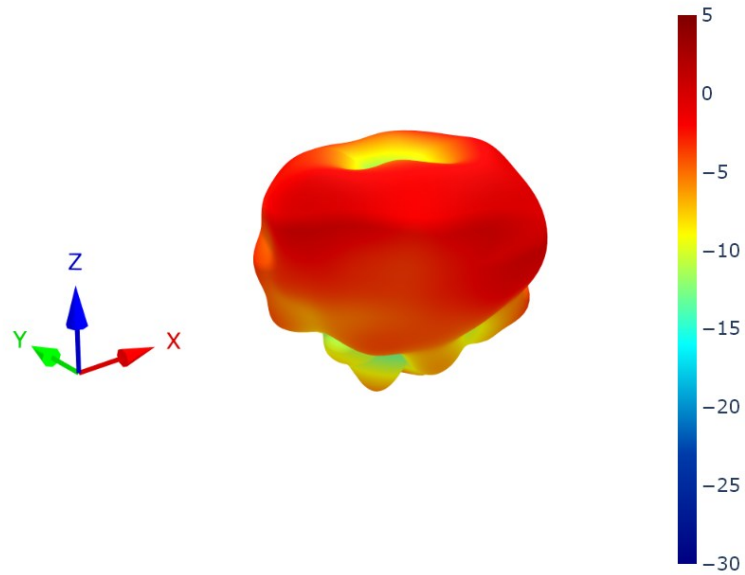

7.39 30x30cm Ground Plane Straight Patterns at 1950 MHz

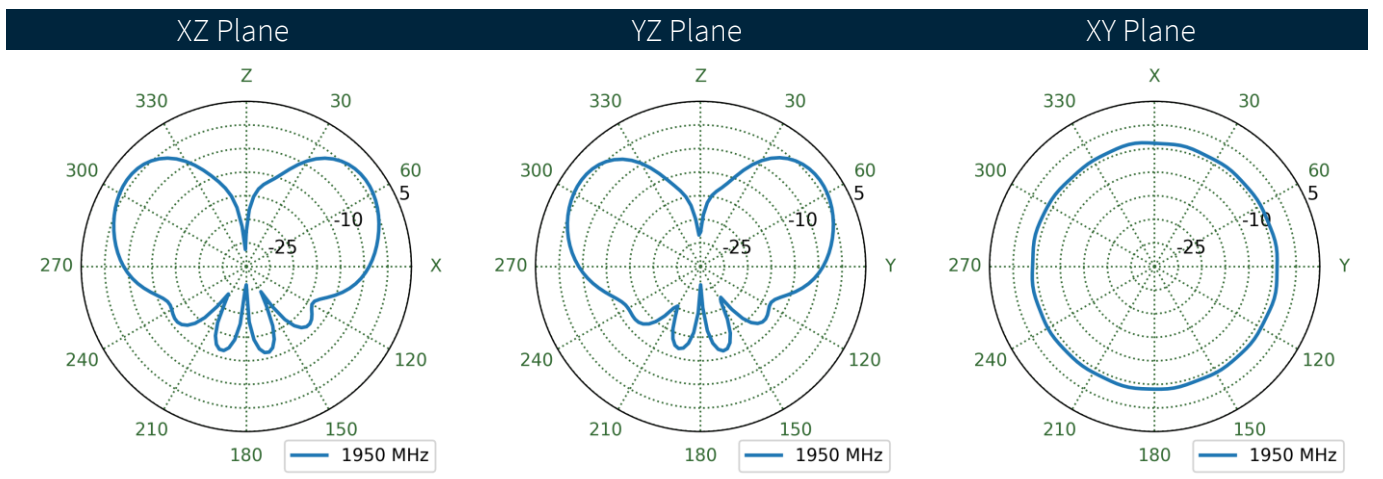
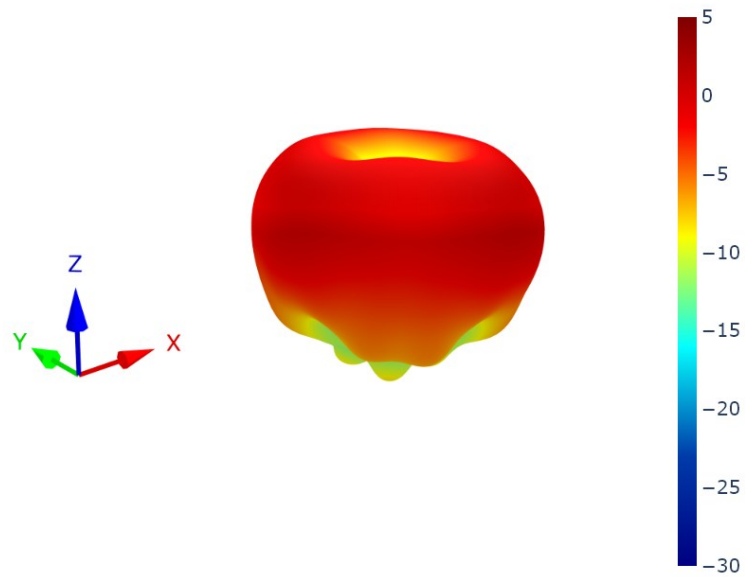

7.40 Free Space Bent Patterns at 1950 MHz

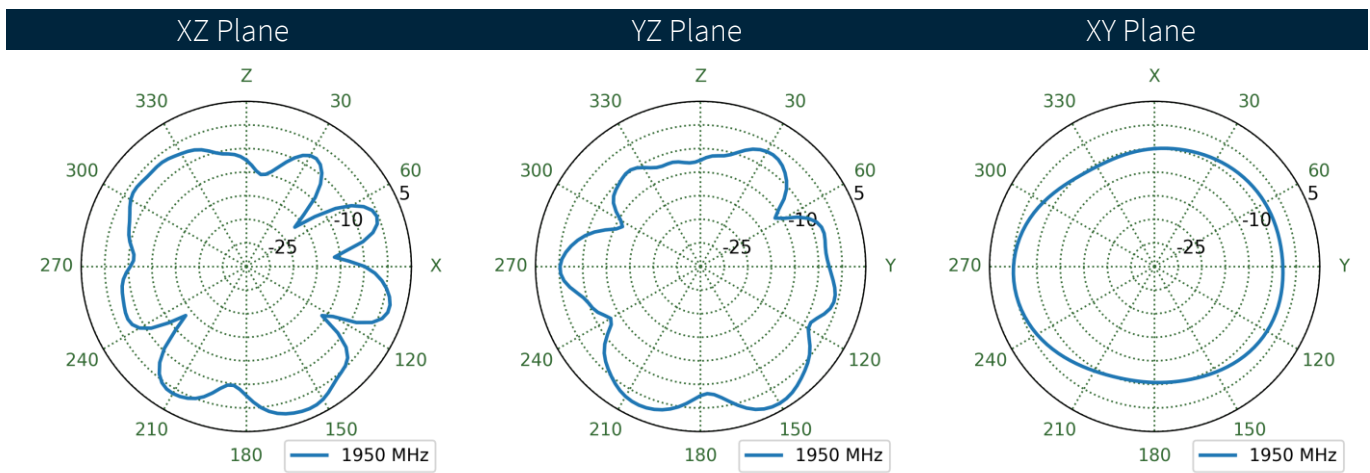
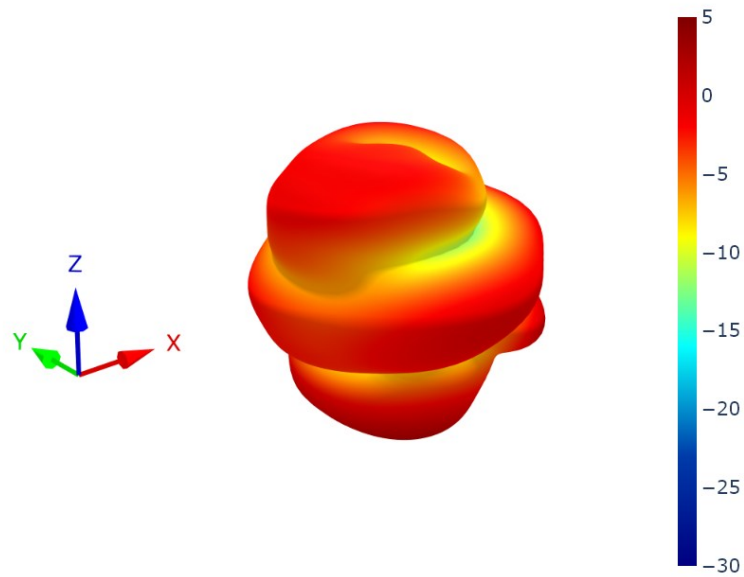

7.41 Free Space Straight Patterns at 1950 MHz

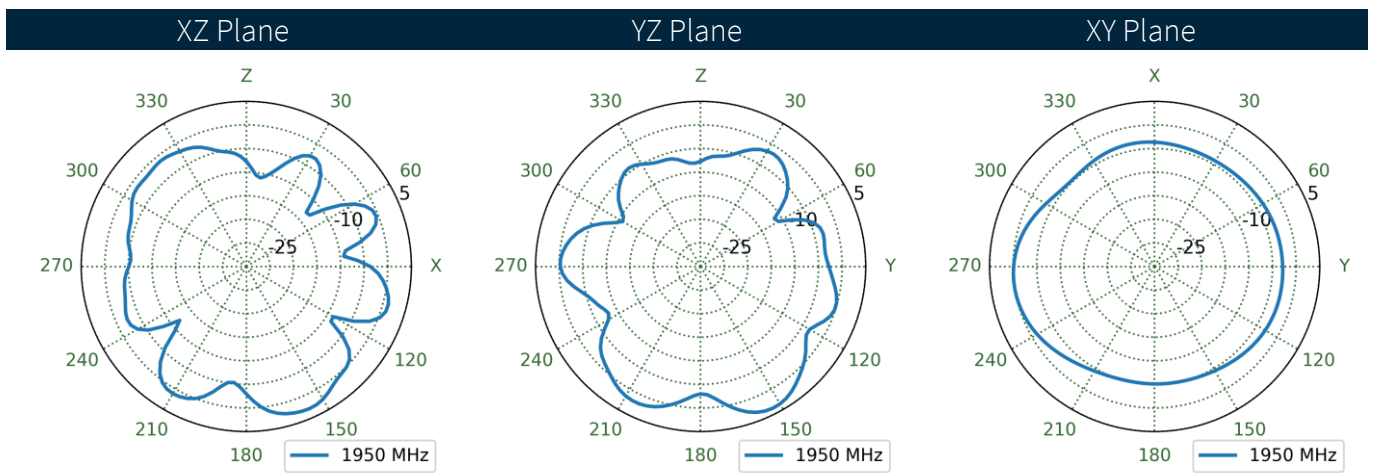
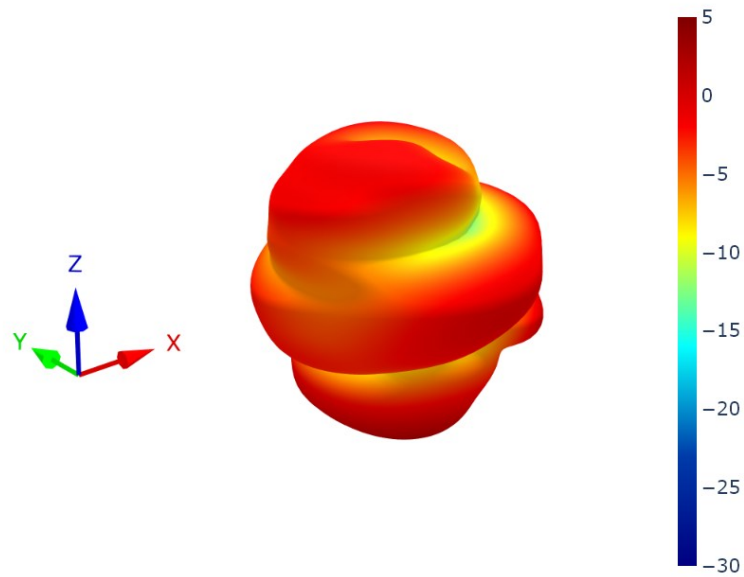

7.42 15x9cm Ground Plane Bent Patterns at 2490 MHz

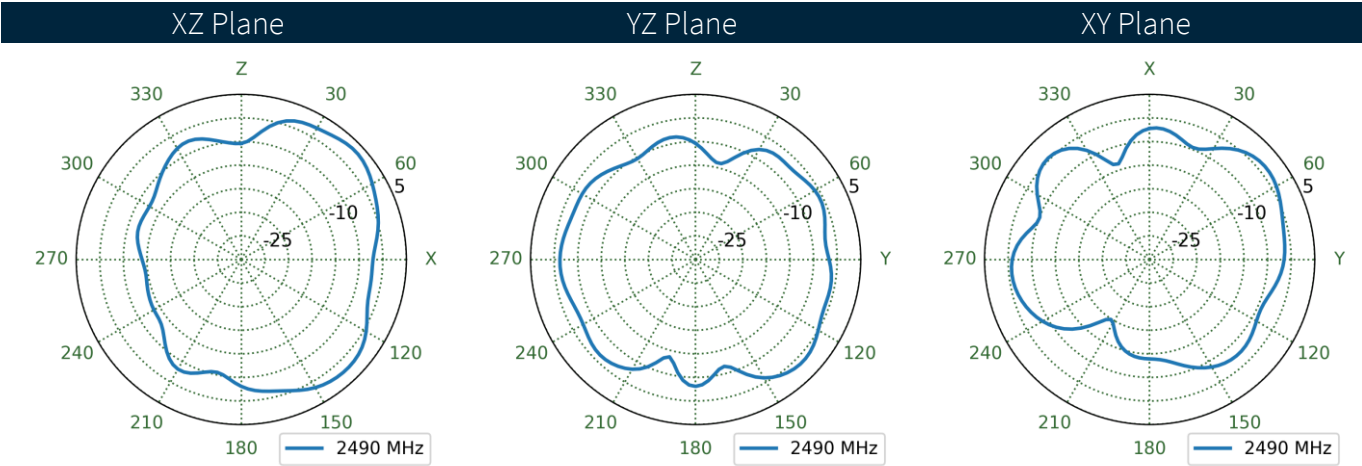
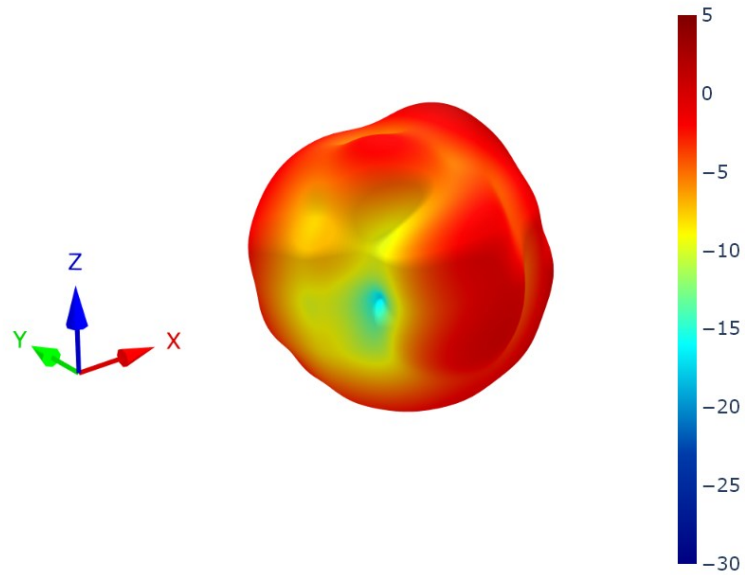

7.43 15x9cm Ground Plane Straight Patterns at 2490 MHz

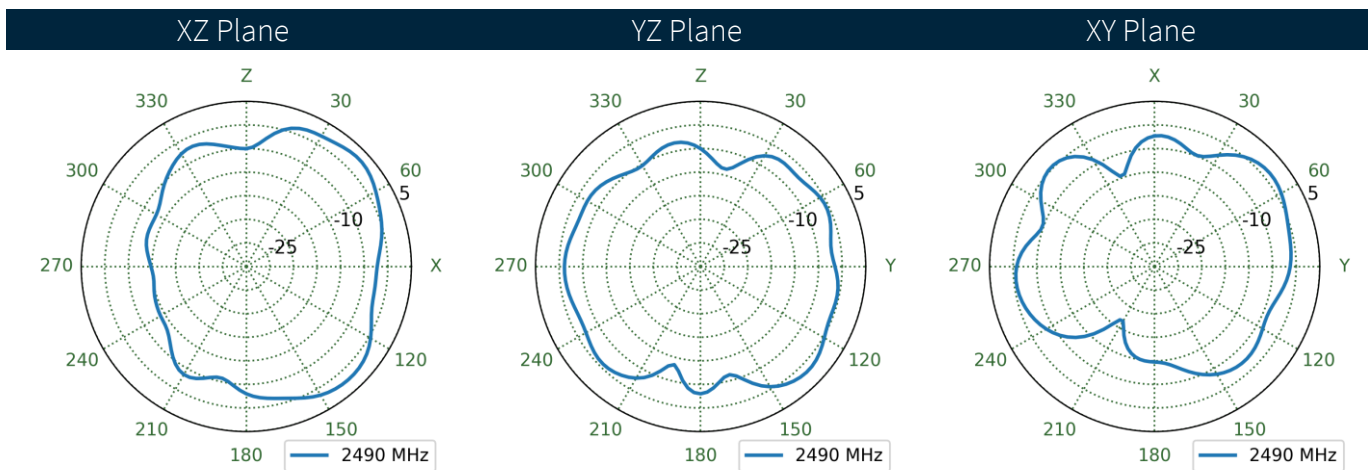
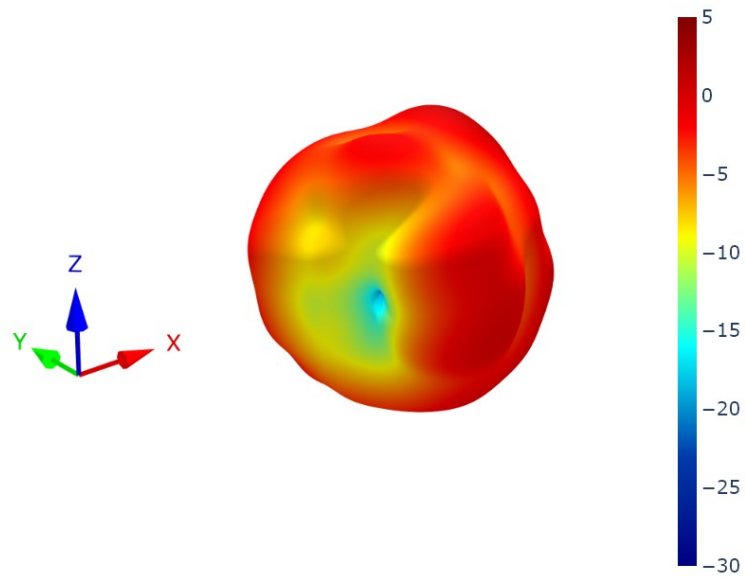

7.44 30x30cm Ground Plane (Edge) Bent Patterns at 2490 MHz

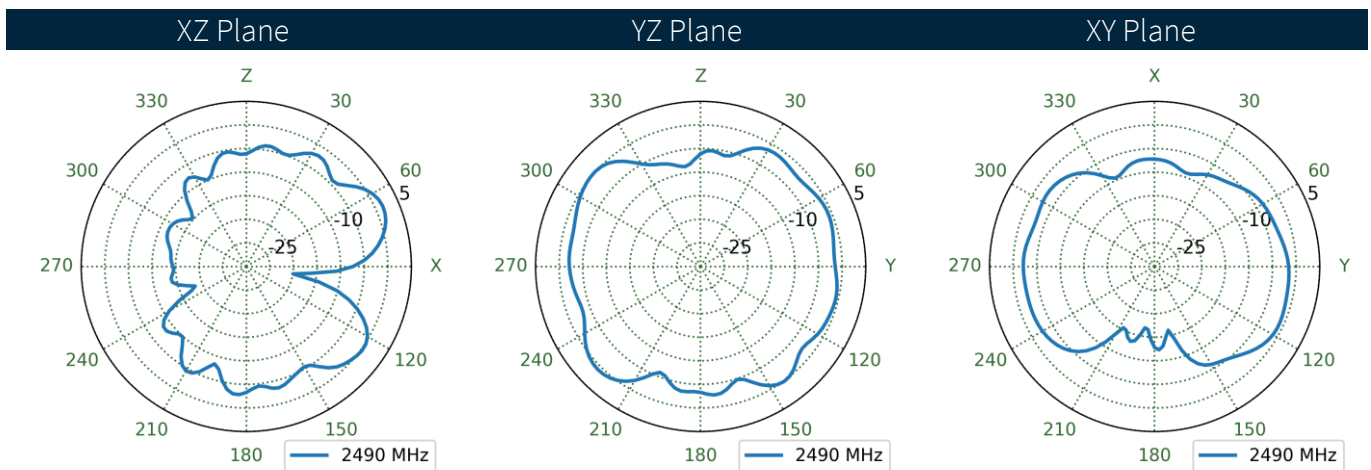
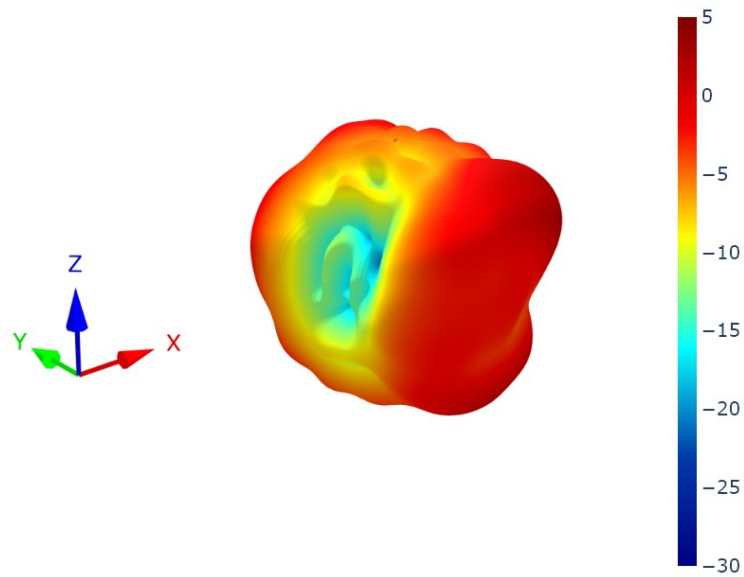



7.45 30x30cm Ground Plane (Edge) Straight Patterns at 2490 MHz

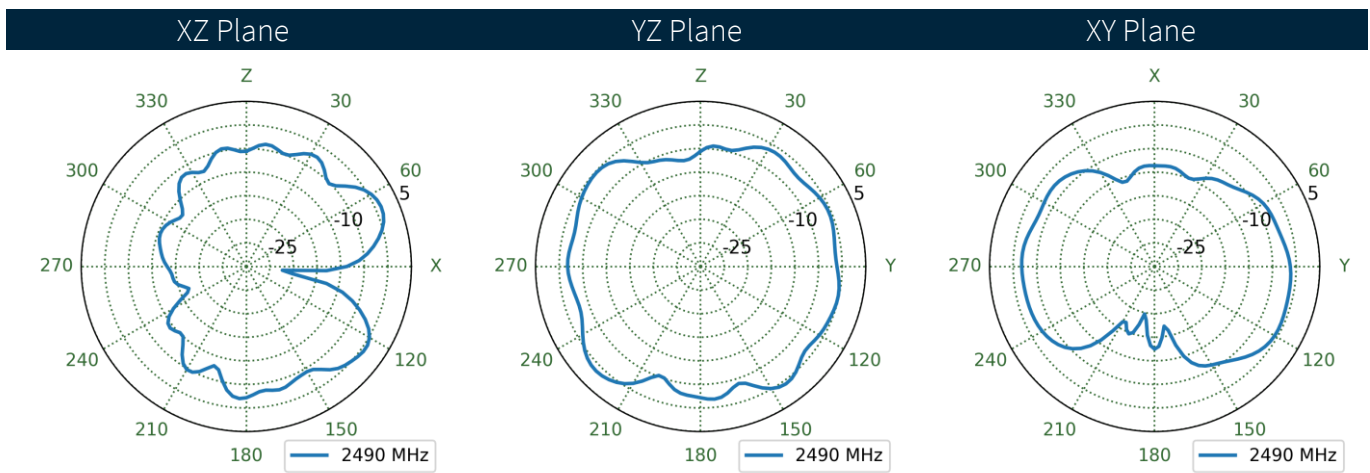
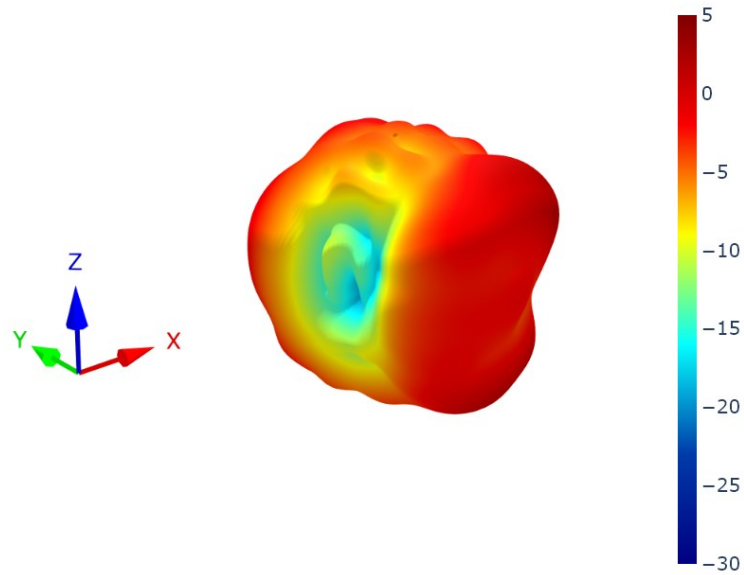

7.46 30x30cm Ground Plane Bent Patterns at 2490 MHz

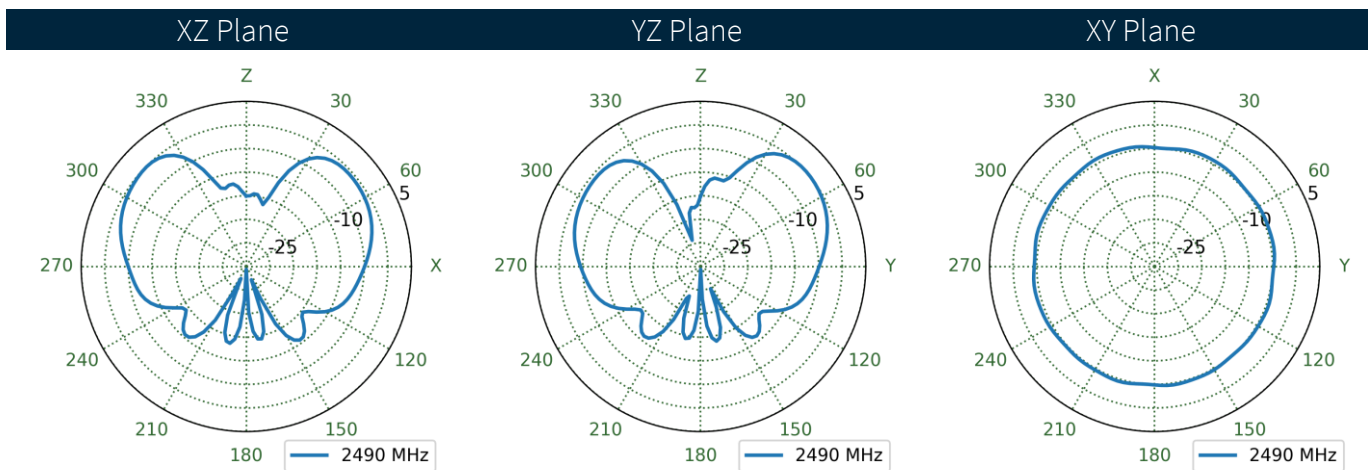
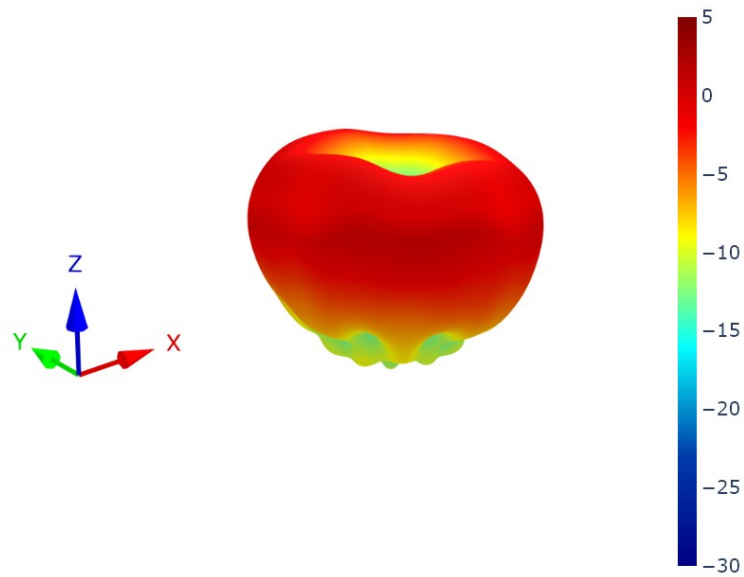

7.47 30x30cm Ground Plane Straight Patterns at 2490 MHz

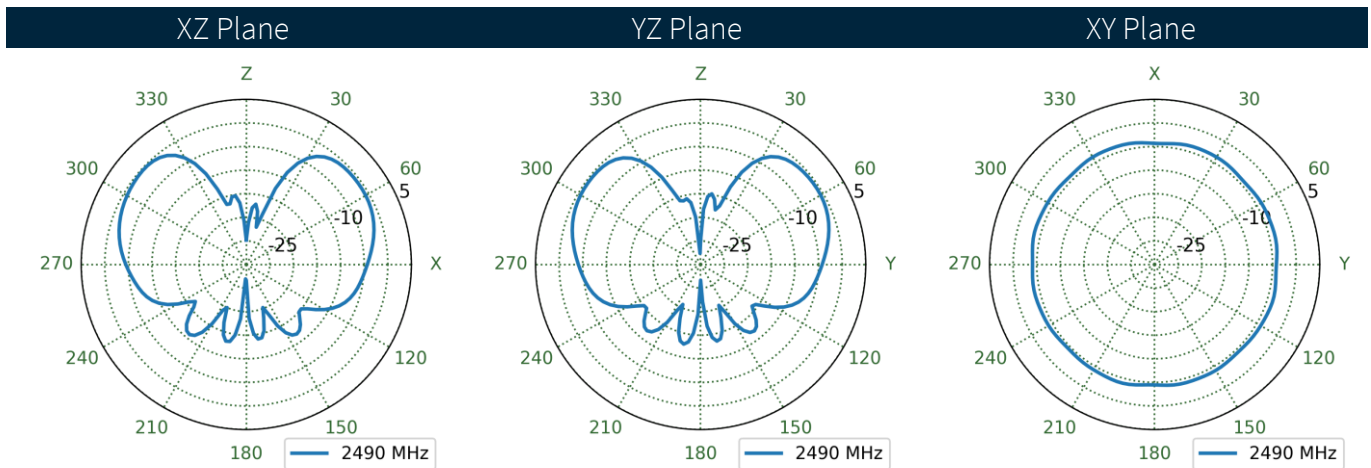
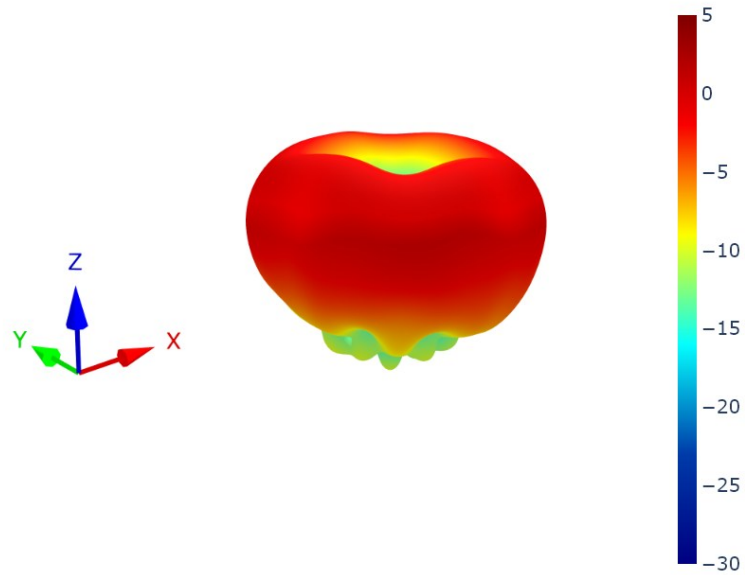

7.48 Free Space Bent Patterns at 2490 MHz

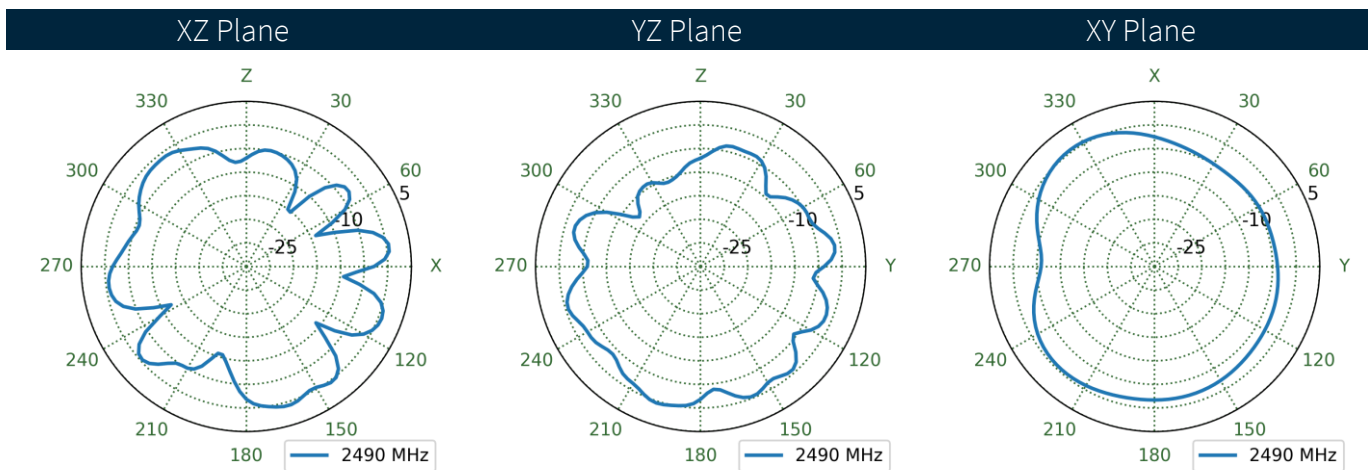
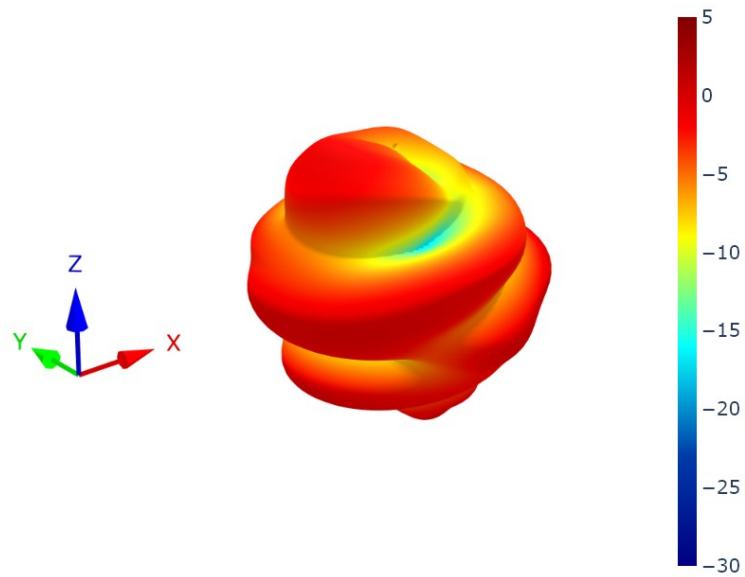

7.49 Free Space Straight Patterns at 2490 MHz

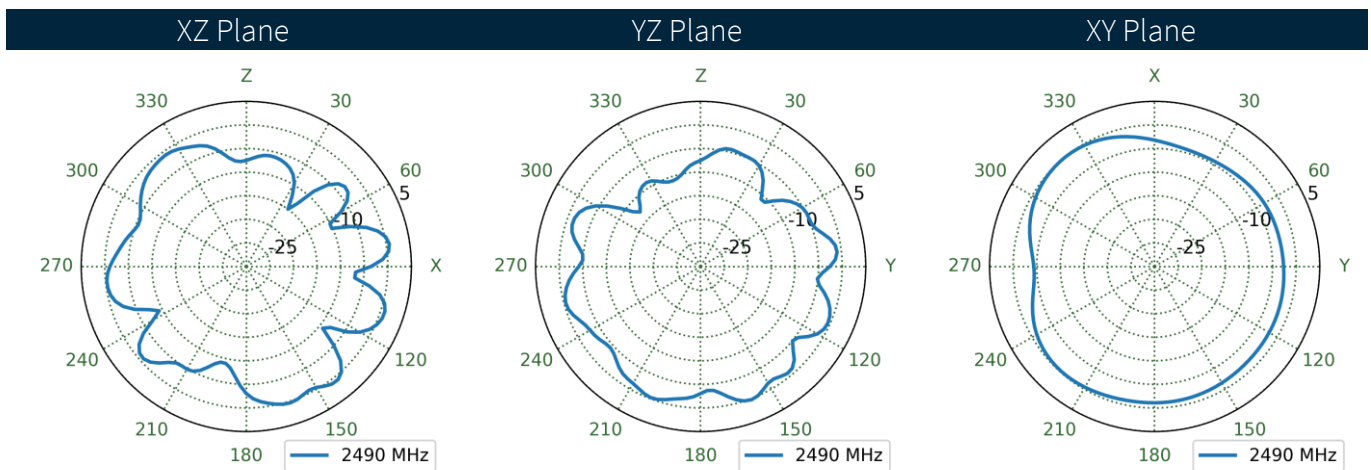
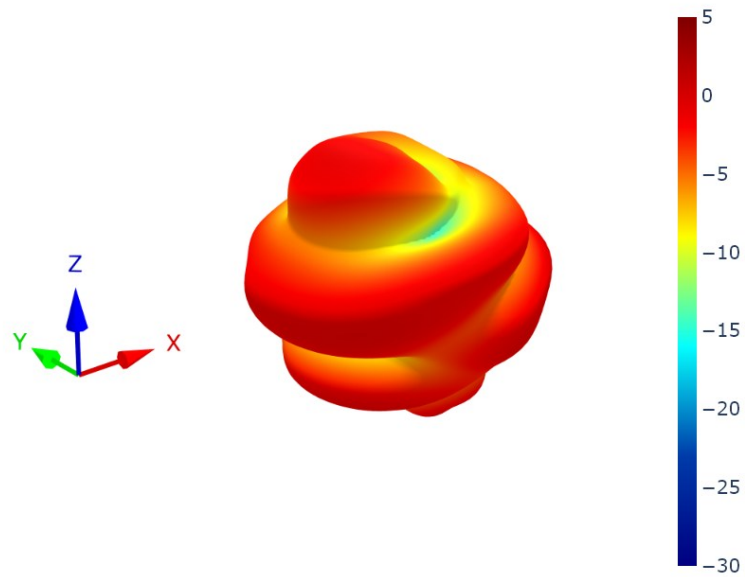

Changelog for the datasheet

**SPE-14-8-116 - TG.08.0113**

**Revision: F (Current Version)**

Date:	2025-02-28
Notes:	Full datasheet update.
Author:	Gary West

**Previous Revisions**

**Revision: E**

Date:	2025-02-10
Notes:	Drawing updated
Author:	Cesar Sousa

**Revision: D**

Date:	2017-04-04
Notes:	Added LTE Band Table
Author:	Peter Monahan

**Revision: C**

Date:	2016-07-10
Notes:	Updated drawing
Author:	Andy Mahoney

**Revision: B**

Date:	2016-07-10
Notes:	Amended inaccuracies
Author:	Andy Mahoney

**Revision: A (Original First Release)**

Date:	2014-11-19
Notes:	
Author:	Technical Writer



[www.taoglas.com](http://www.taoglas.com)

