

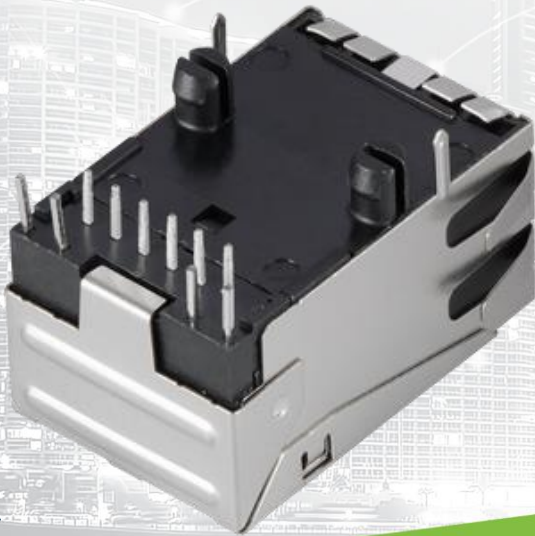

TAOGLAS®



Datasheet

RJ45 ICM 10/100 Base-T

Part No:
TMJ0122-7KONL

Description:

RJ45 connector with integrated magnetics 10/100 Base-T
Single Port Tab-UP with right angle THT mount and LEDs

Features:

- Transformer + CMC
- Shielded EMI Finger
- Industrial grade
- RoHS Compliant

1. Introduction	3
2. Specifications	4
3. Mechanical	5
4. Electrical	6
5. Packaging	7
<hr/>	
Changelog	8

Taoglas makes no warranties based on the accuracy or completeness of the contents of this document and reserves the right to make changes to specifications and product descriptions at any time without notice. Taoglas reserves all rights to this document and the information contained herein. Reproduction, use or disclosure to third parties without express permission is strictly prohibited.



1. Introduction



The Taoglas TMJ0122-7KONL is a 10/100 Base-T single-port, tab-UP RJ45 Integrated Connector with a shielded EMI Finger. It features a widely recognized footprint and a compatible package that aligns with industry standards for RJ45 Integrated Connectors, making it popular among users.

Typical Applications Include:

- Industrial Automation
- Hubs
- Routers
- Switches
- Wireless Access Points

Taoglas Magnetics offer an extensive product line of RJ45 Integrated Connectors designed for commercial and industrial grade applications, supporting 10/100 Base-T (Atmos100 Series) and 1G Base-T (Atmos1000 series). These surface mount or through-hole components provide reliable performance and maintain signal integrity that meets IEEE 802.3 standards, and they are UL certified. The Power over Ethernet options are also available including PoE, PoE+ and PoE++.

The majority of Taoglas RJ45 ICMs are manufactured with fully automated winding, assembly & testing to ensure consistent performance, quality and reliability while ensuring cost competitiveness for its customers. These products are fully compliant with the REACH and RoHS directive, and compatible with all major PHY vendors.

For customized products or support with integration, contact your regional Taoglas customer support team for further information.

2. Specifications

Electrical Performance @25°C	
OCL	350uH Min @100KHz,0.1V,8mA DC BIAS
Turns Ratio (±2%)	1CT:1CT
Insertion Loss	1-65MHz: -1.0dB Max
Return Loss (dB Min)	1-10MHz: -20
	10-30MHz: -16
	30-60MHz: -12
	60-100MHz: -10
Crosstalk (dB min)	1-30MHz: -40
	30-60MHz: -35
	60-100MHz: -30
CMR (dB Min)	1-50MHz: -30
	50-150MHz: -20
Isolation PHY SIDE To Line SIDE	1500Vrms

Environmental Specifications	
Operating Temperature	-40°C TO +85°C

Material Specifications	
Housing	Thermoplastic PBT+30%G.F UL94V-0
Contact	Phosphor Bronze C5210R-EH Thickness=0.35mm
Pins	Brass C2680R-H Thickness=0.35mm
Shield	SUS 201-1/2H Thickness=0.2mm
Contact plating	Gold 15 micro-inches min. in contact area
Wave solder tip temperature	250°C Max, 5 Sec

Compliance	
UL recognized - FILE NO. E528697	
IEEE 802.3	
RoHS Compliant	

Storage requirements	
Humidity	MSL - 1
Storage Temperature	-40°C TO +85°C

3. Mechanical

3.1 Mechanical Drawings

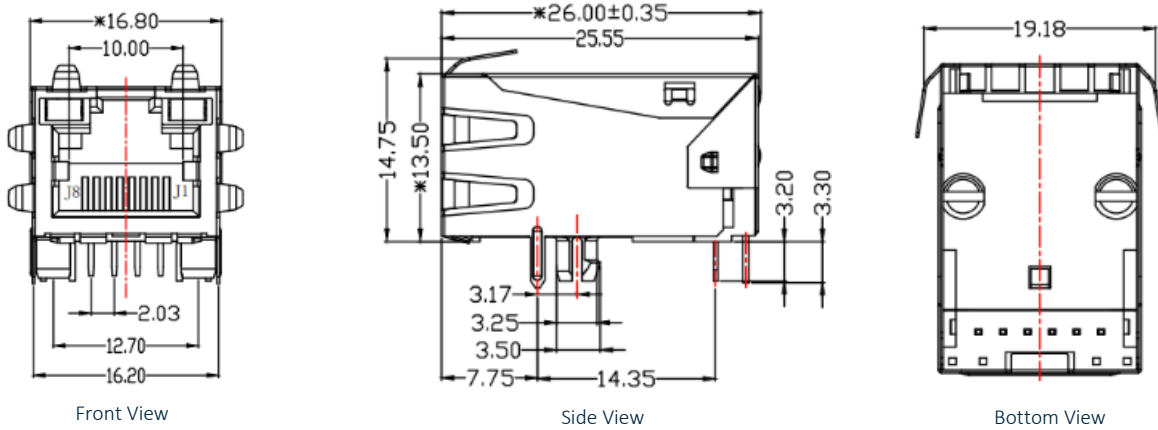

Mechanical Specifications	
Height	14.75 mm
Width	16.80 mm
Depth	26 mm
Weight	7.75 g
Mounting Style	Through Hole (THT)
Mounting Angle	Right Angle

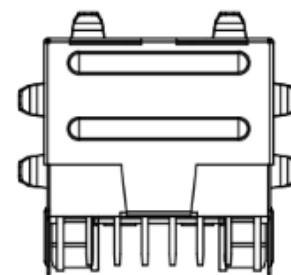

Back View

Dimensions are in millimeters with the following tolerances: X.XX = ±0.25

3.2 PCB Layout

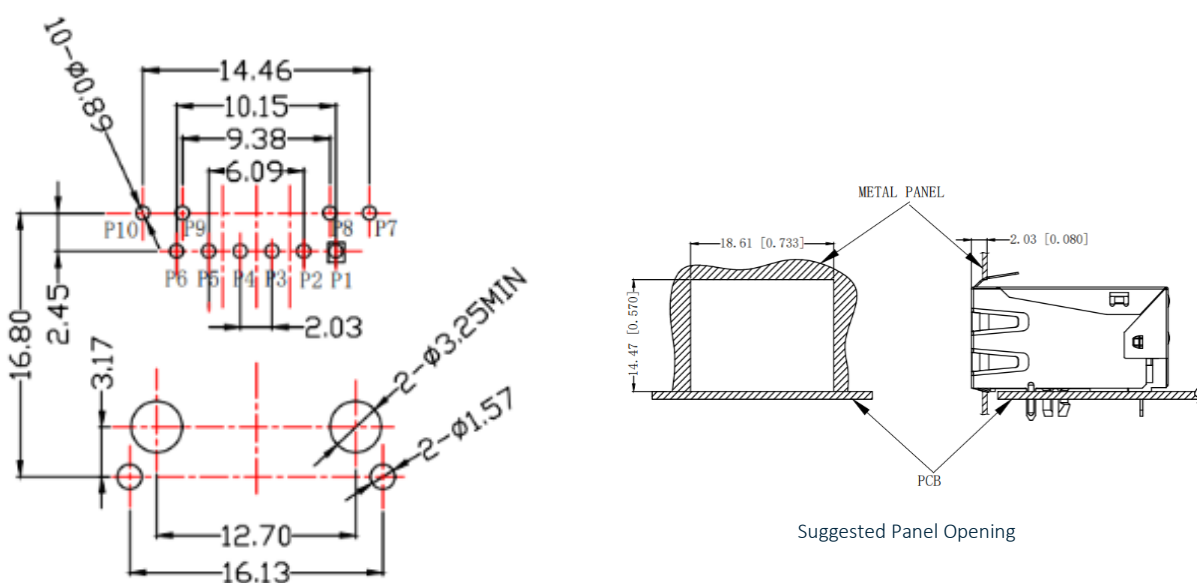

Suggested PCB Layout (Top View)

Dimensions are in millimeters with the following tolerances: X.XX = ±0.10

4. Electrical

4.1 Electrical Drawings

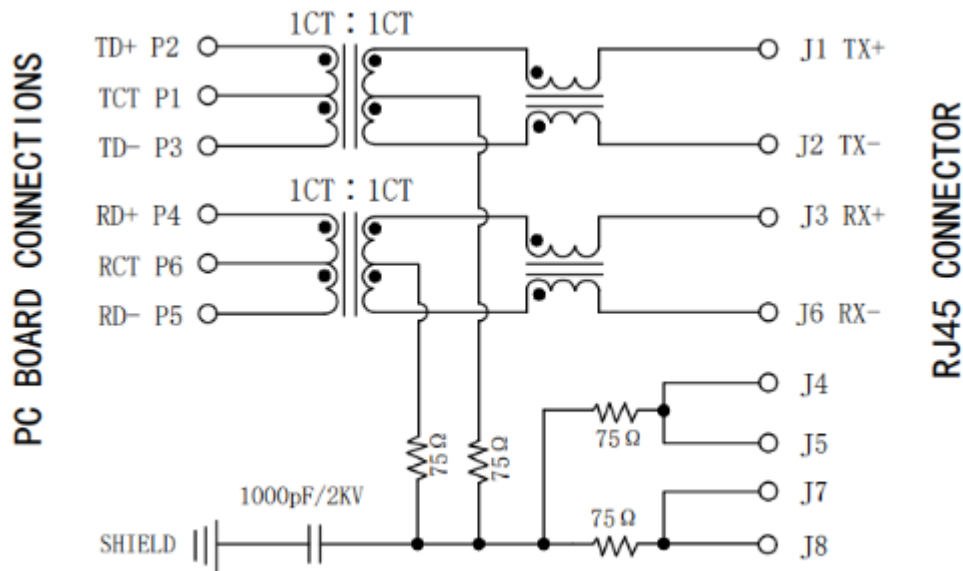

LED Electrical Specification

Standard LED	Wavelength (nm)	V_F ($I_F=20\text{mA}$)	I_R ($V_R=5\text{v}$)
Orange/Green	610/570	1.8~2.6v	10 μA Max
Yellow	585	1.8~2.6v	10 μA Max

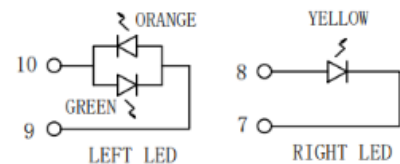

4.2 Profile of Wave Solder

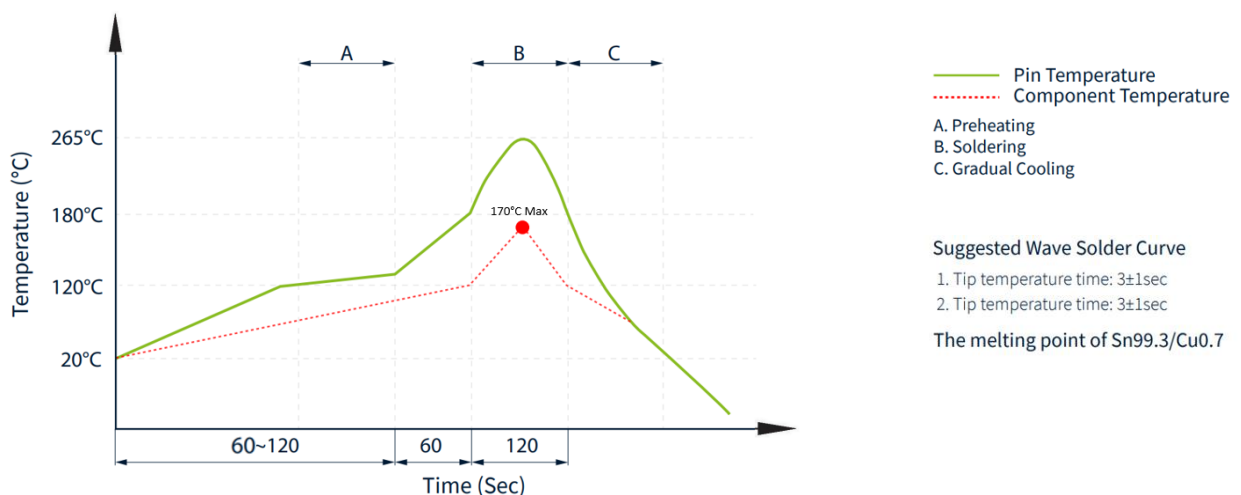

5. Packaging

5.1 SPQ

50 pcs/tray

Tray dimension: 299*163*28 mm

Tray Weight: 0.48 kg

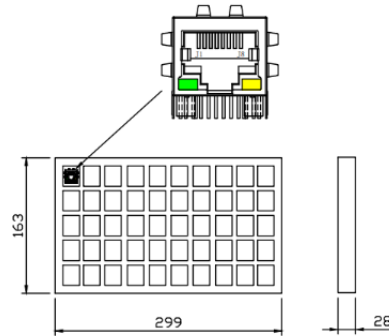

5.2 Carton

1 Carton = 24 trays = 1200 pcs

Carton dimensions: 400*320*313 mm

Carton Weight: 12.4 kg



5.3 Label

Taoglas Limited	
P/N NO: XXXXXXXX	
QYT: XXX PCS	DC: XXXX
DATE: XXXX-XX-XX	

SPQ Label (8x4cm)

Taoglas Limited	
P/N NO: XXXXXXXX	
PO: XXXXXXXX	B/N: XXXXXXXX
QYT: XXX PCS	DC: XXXX
DATE: XXXX-XX-XX	

Carton Label (8x4cm)

Changelog

Changelog for the datasheet

SPE-23-8-357 – TMJ0122-7KONL

Revision: A (Original First Release)

Date:	2024-01-01
Notes:	
Author:	Javier Vasena

Previous Revisions



www.taoglas.com

