



TAOGLAS®



Datasheet

RJ45 ICM 10/100 Base-T Vertical w/Step

Part No:
TMJD1011BENL

Description:

RJ45 connector with integrated magnetics 10/100 Base-T
Single Port Vertical THT mount and LEDs

Features:

Transformer + CMC
Shielded with Step
RoHS Compliant

1. Introduction	3
2. Specifications	4
3. Mechanical	5
4. Electrical	6
5. Packaging	7
<hr/>	
Changelog	8

Taoglas makes no warranties based on the accuracy or completeness of the contents of this document and reserves the right to make changes to specifications and product descriptions at any time without notice. Taoglas reserves all rights to this document and the information contained herein. Reproduction, use or disclosure to third parties without express permission is strictly prohibited.



1. Introduction



The Taoglas TMJD1011BENL is a 10/100 Base-T single-port, vertical RJ45 Integrated Connector with a shielded body design. It features a widely recognized footprint and a compatible package that aligns with industry standards for RJ45 Integrated Connectors, making it popular among users.

Typical Applications Include:

- Industrial Automation
- Hubs
- Routers
- Switches
- Wireless Access Points

Taoglas Magnetics offer an extensive product line of RJ45 Integrated Connectors designed for commercial and industrial grade applications, supporting 10/100 Base-T (Atmos100 Series) and 1G Base-T (Atmos1000 series). These surface mount or through-hole components provide reliable performance and maintain signal integrity that meets IEEE 802.3 standards, and they are UL certified. The Power over Ethernet options are also available including PoE, PoE+ and PoE++.

The majority of Taoglas RJ45 ICMs are manufactured with fully automated winding, assembly & testing to ensure consistent performance, quality and reliability while ensuring cost competitiveness for its customers. These products are fully compliant with the REACH and RoHS directive, and compatible with all major PHY vendors.

For customized products or support with integration, contact your regional Taoglas customer support team for further information.

2. Specifications

Electrical Performance @25°C	
Inductance OCL	350uH Min @100KHz, 0.1V, 8mA DC Bias
Turns Ratio (±2%)	1CT:1CT
Insertion Loss	-1.1dB MAX @ 0.1~100MHz
Return Loss	-18dB MIN @ 0.5~30MHz
	-15.5dB MIN @ 40MHz
	-13.6dB MIN @ 50MHz
	-12dB MIN @ 60~80MHz
Crosstalk	-40dB TYP @ 0.1~100MHz
Common Mode Rejection	-50dB TYP @ 0.1~30MHz
	-40dB TYP @ 30~60MHz
	-35dB TYP @ 60~100MHz
Hipot	1500Vrms MIN

Environmental Specifications	
Operating Temperature	0°C TO +70°C

Material Specifications	
Housing	Thermoplastic PBT+30%G.F UL94V-0
Contact	Phosphor Bronze C5210R-EH Thickness=0.35mm
Pins	Brass C2680R-H Thickness=0.35mm
Shield	Copper alloy Brass H65Y Thickness=0.2mm
Contact plating	Gold 6 micro-inches min. in contact area.
Wave solder tip temperature	260°C Max, 5 Sec

Compliance	
UL recognized - FILE NO. E528697	
IEEE 802.3	
RoHS Compliant	

Storage requirements	
Humidity	MSL - 1
Storage Temperature	-40°C TO +85°C

3. Mechanical

3.1 Mechanical Drawings

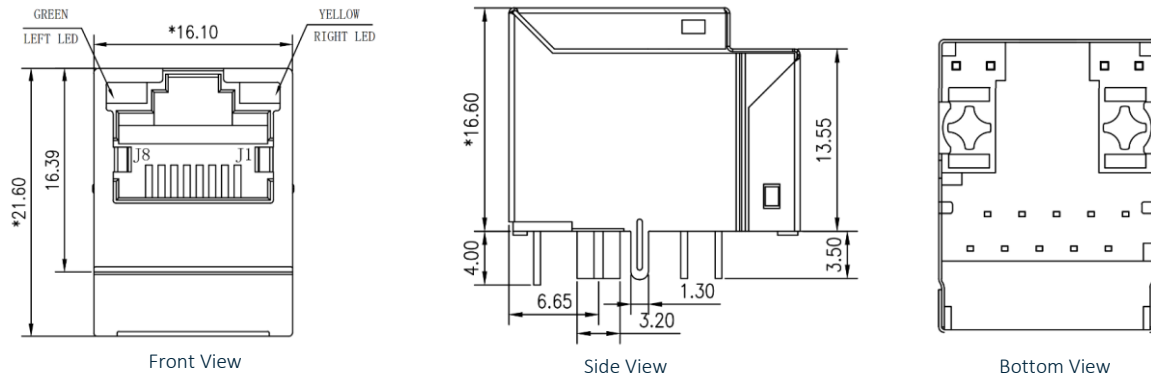

Mechanical Specifications	
Height	16.60mm
Width	16.10mm
Depth	21.60mm
Weight	6.5g
Mounting Style	Through Hole (THT)
Mounting Angle	Right Angle

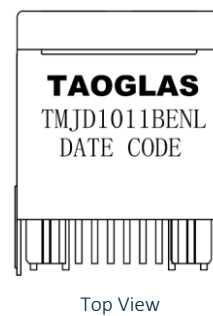

Dimensions are in millimeters with the following tolerances: X.XX = ±0.25

3.2 PCB Layout

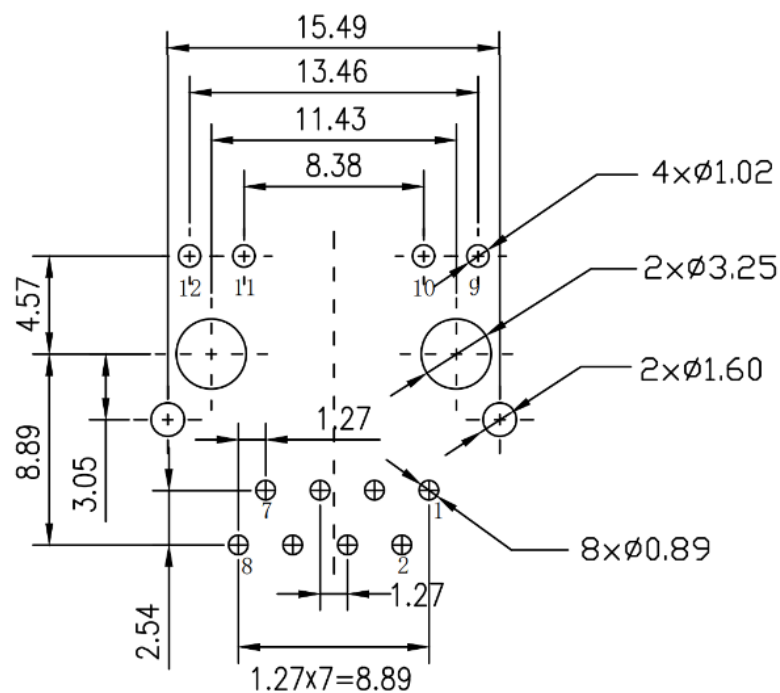

Suggested PCB Layout (Top View)

Dimensions are in millimeters with the following tolerances: X.XX = ±0.10

4. Electrical

4.1 Electrical Drawings

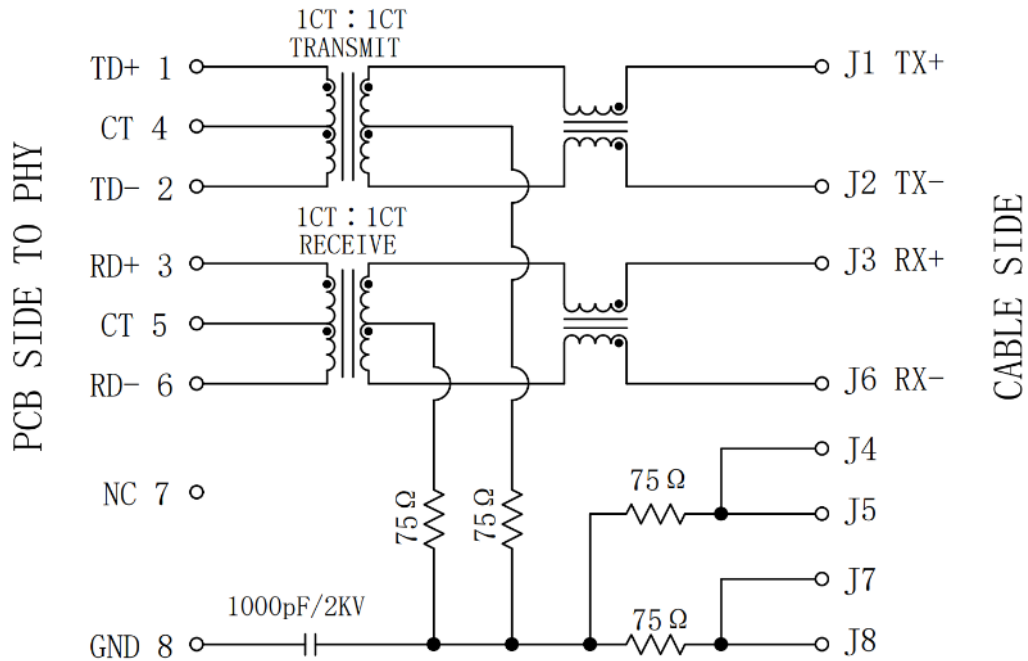

LED Electrical Specification

Standard LED	Wavelength (nm)	V_F ($I_F=20mA$)	I_R ($V_R=5v$)
Green	565	1.8~2.6v	10 μA Max
Yellow	585	1.8~2.6v	10 μA Max

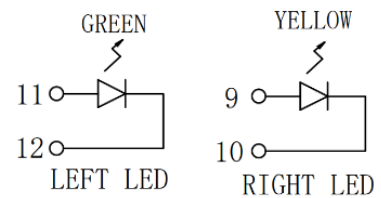

4.2 Profile of Wave Solder

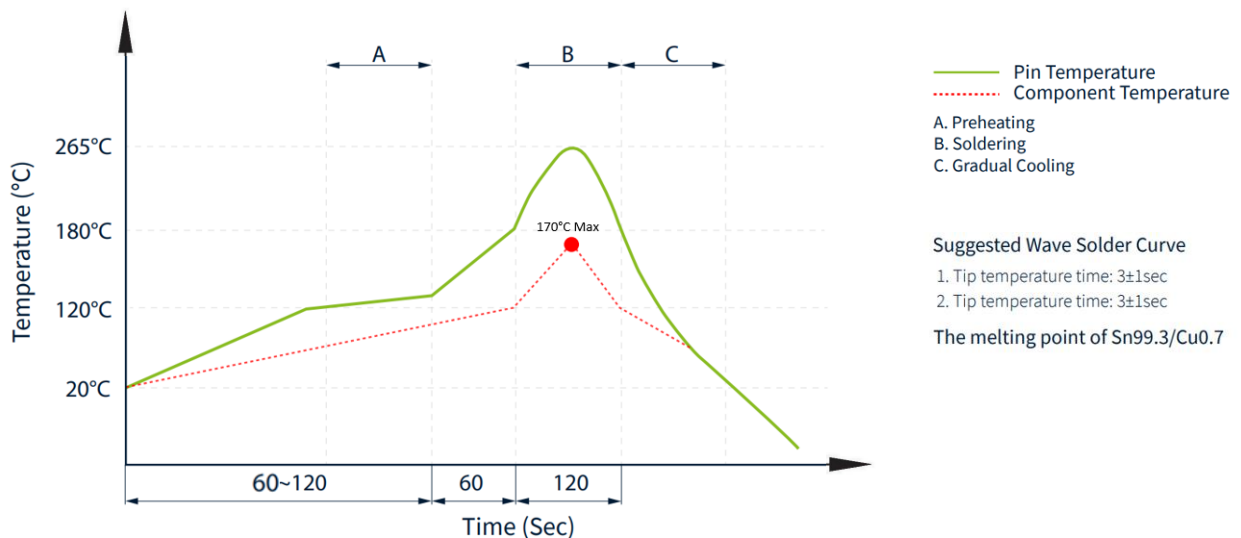

5. Packaging

5.1 SPQ

50 pcs/tray

Tray dimension: 283*146*26 mm

Tray Weight: 440g

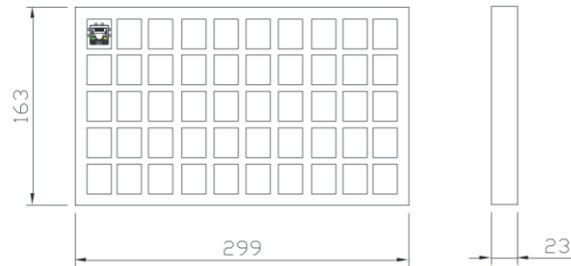

1 Carton = 20 trays = 1000 pcs

Carton dimensions: 320*300*310mm

Carton Weight: 9kg



5.2 Label

Taoglas Limited	
P/N NO: XXXXXXXX	
QYT: XXX PCS	DC: XXXX
DATE: XXXX-XX-XX	

SPQ Label (8x4cm)

Taoglas Limited	
P/N NO: XXXXXXXX	
PO: XXXXXXXX	B/N: XXXXXXXX
QYT: XXX PCS	DC: XXXX
DATE: XXXX-XX-XX	

Carton Label (8x4cm)

Changelog

Changelog for the datasheet

SPE-23-8-211 – TMJD1011BENL

Revision: A (Original First Release)

Date:	2023-10-01
Notes:	
Author:	Javier Vasena

Previous Revisions



www.taoglas.com

