

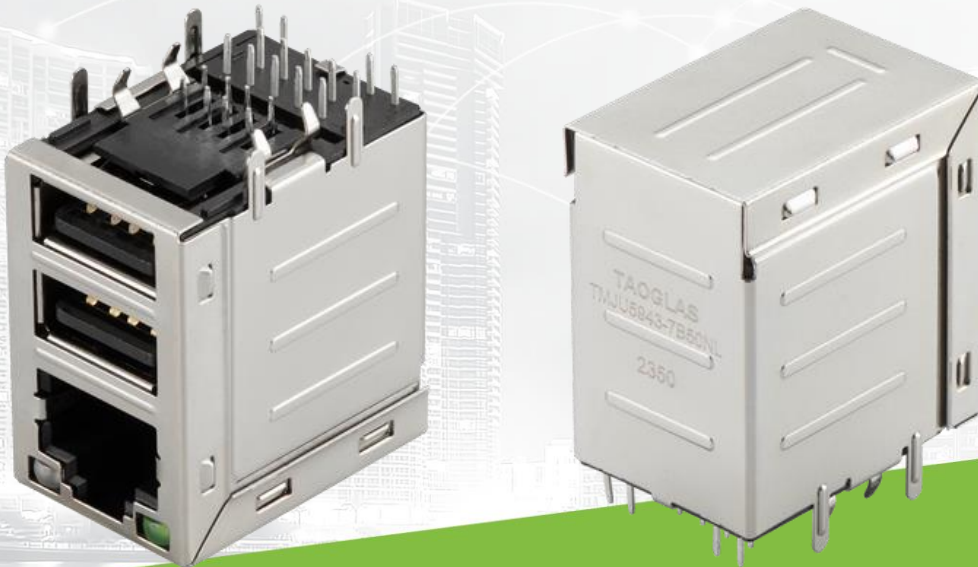

TAOGLAS®



Datasheet

RJ45 ICM 1G Base-T USB Combo

Part No:
TMJU5943-7B50NL

Description:

RJ45 connector with integrated magnetics 1G Base-T USB Combo
Single Port Tab-UP with right angle THT mount and LEDs

Features:

- 1*RJ+2*USB
- 3Wire+XFMR
- Current drive
- Shielded EMI Finger
- Industrial grade
- RoHS Compliant

1.	Introduction	3
2.	Specifications	4
3.	Mechanical	5
4.	Electrical	6
5.	Packaging	7
<hr/>		
	Changelog	8

Taoglas makes no warranties based on the accuracy or completeness of the contents of this document and reserves the right to make changes to specifications and product descriptions at any time without notice. Taoglas reserves all rights to this document and the information contained herein. Reproduction, use or disclosure to third parties without express permission is strictly prohibited.



1. Introduction



The Taoglas TMJU5943-7B50NL is a 1G Base-T USB Combo/Dual USB, tab-UP RJ45 Integrated Connector with a shielded design. It features a widely recognized footprint and a compatible package that aligns with industry standards for RJ45 Integrated Connectors, making it popular among users.

Typical Applications Include:

- Industrial Automation
- Hubs
- Routers
- Switches
- Wireless Access Points

Taoglas Magnetics offer an extensive product line of RJ45 Integrated Connectors designed for commercial and industrial grade applications, supporting 10/100 Base-T (Atmos100 Series) and 1G Base-T (Atmos1000 series). These surface mount or through-hole components provide reliable performance and maintain signal integrity that meets IEEE 802.3 standards, and they are UL certified. The Power over Ethernet options are also available including PoE, PoE+ and PoE++.

The majority of Taoglas RJ45 ICMs are manufactured with fully automated winding, assembly & testing to ensure consistent performance, quality and reliability while ensuring cost competitiveness for its customers. These products are fully compliant with the REACH and RoHS directive, and compatible with all major PHY vendors.

For customized products or support with integration, contact your regional Taoglas customer support team for further information.

2. Specifications

Electrical Performance @25°C	
OCL	350uH Min @100KHz,0.1V,8mA DC BIAS
Turns Ratio (±3%)	1CT:1CT
DCR	1.2Ω MAX
Insertion Loss	-1.0dB MAX @1-100MHz
Return Loss	18dB MIN @1-30MHz
	-16dB MIN @30-60MHz
	-12dB MIN @60-100MHz
Crosstalk	-35dB MIN @1-100MHz
Common Mode Rejection	-30dB MIN @1-100MHz
Isolation PHY SIDE To Line SIDE	1500Vrms

Environmental Specifications	
Operating Temperature	-40°C TO +85°C

Material Specifications	
Housing	Thermoplastic PBT+30%G.F UL94V-0
Contact	Phosphor Bronze C5210R-EH Thickness=0.35mm
Pins	Brass C2680R-H Thickness=0.35mm
Shield	SUS 201-1/2H Thickness=0.2mm
Contact plating	Gold 15 micro-inches min. in contact area
Wave solder tip temperature	250°C Max, 5 Sec

Compliance	
UL recognized - FILE NO. E528697	
IEEE 802.3	
RoHS Compliant	

Storage requirements	
Humidity	MSL - 1
Storage Temperature	-40°C TO +85°C

3. Mechanical

3.1 Mechanical Drawings

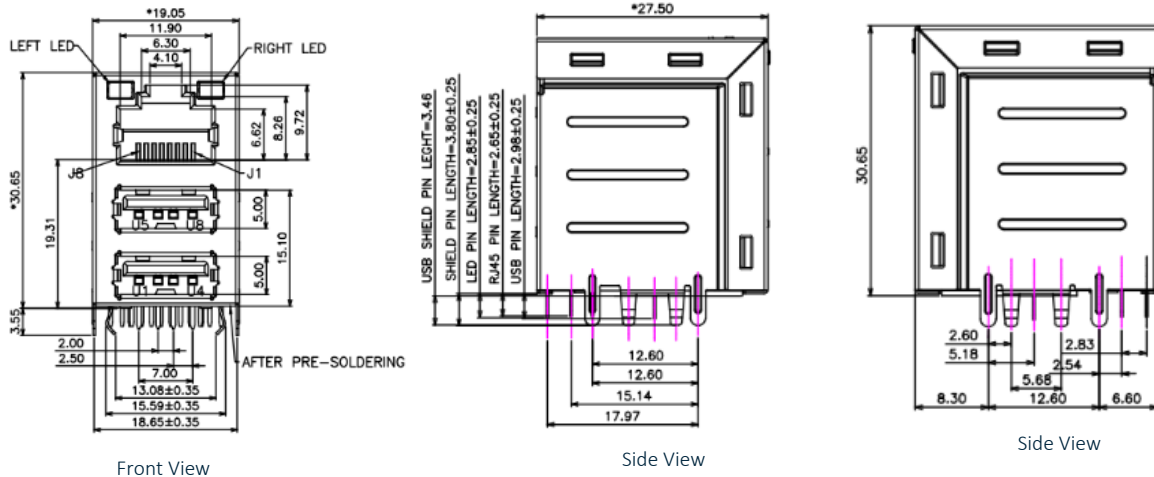

Mechanical Specifications	
Height	30.65 mm
Width	19.05 mm
Depth	27.50 mm
Weight	18.5 g
Mounting Style	Through Hole (THT)
Mounting Angle	Right Angle

Dimensions are in millimeters with the following tolerances: X.XX ± 0.25

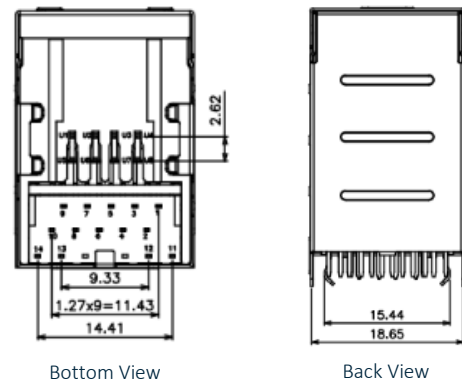

3.2 PCB Layout

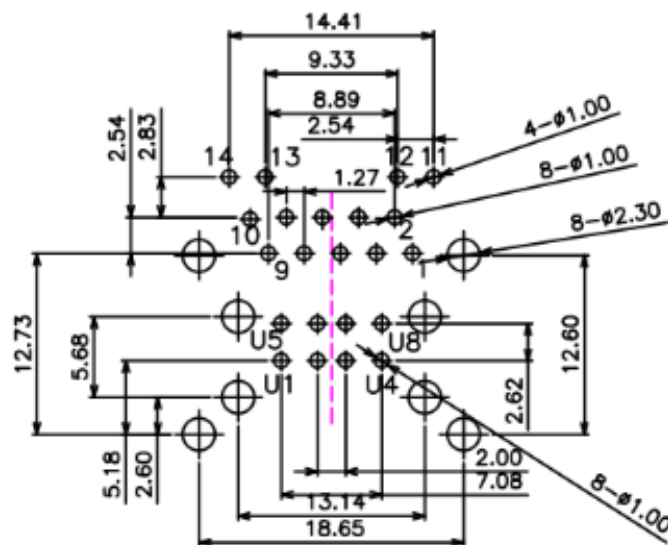

Suggested PCB Layout (Top View)

Dimensions are in millimeters with the following tolerances: X.XX ± 0.10

4. Electrical

4.1 Electrical Drawings

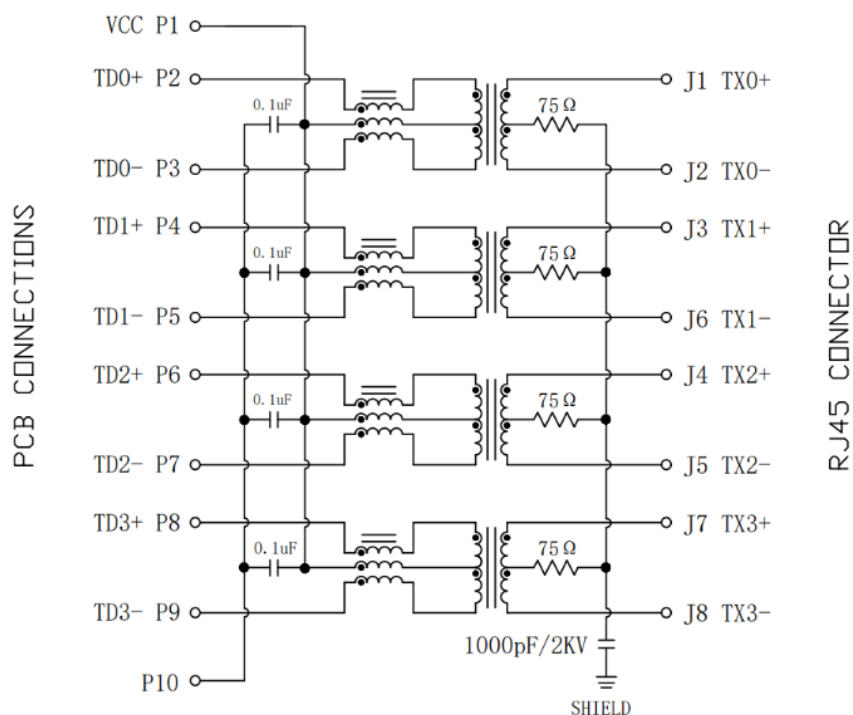

LED Electrical Specification

Standard LED	Wavelength (nm)	V_F ($I_F=20\text{mA}$)	I_R ($V_R=5\text{v}$)
Green	565	1.8~2.6v	10 μA Max
Yellow	585	1.8~2.6v	10 μA Max

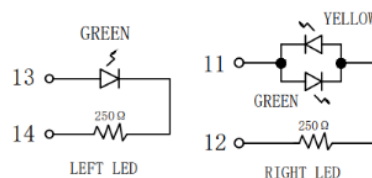

4.2 Profile of Wave Solder

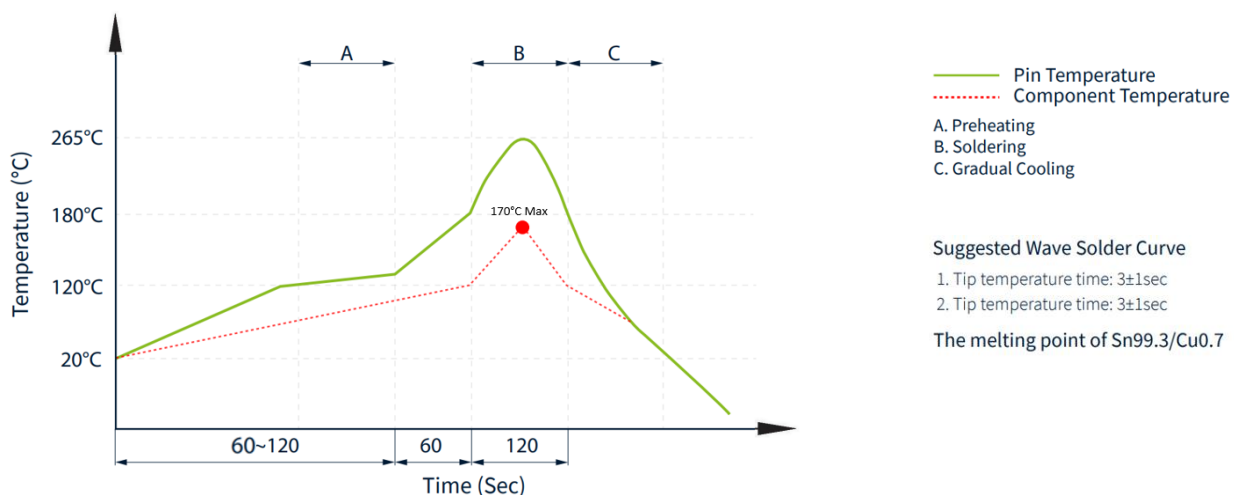

5. Packaging

5.1 SPQ

50 pcs/tray

Tray (mm): 286.5x220.1x51

Tray Weight: 1.08 kg

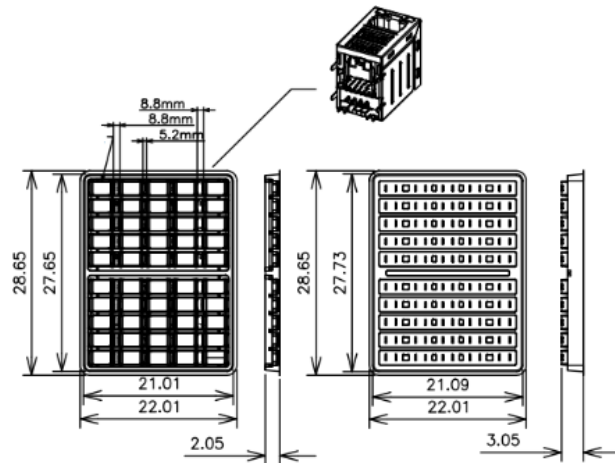

5.2 Carton

1 Carton = 12 trays = 600 pcs

Carton dimensions: 310*455*175 mm

Carton Weight: 11.3 kg

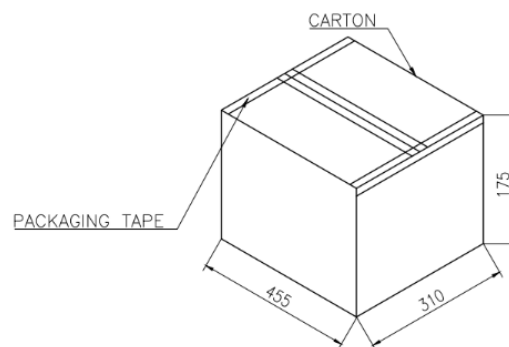

5.3 Label

Taoglas Limited	
P/N NO: XXXXXXXX	
QYT: XXX PCS	DC: XXXX
DATE: XXXX-XX-XX	

SPQ Label (8x4cm)

Taoglas Limited	
P/N NO: XXXXXXXX	
PO: XXXXXXXX	B/N: XXXXXXXX
QYT: XXX PCS	DC: XXXX
DATE: XXXX-XX-XX	

Carton Label (8x4cm)

Changelog

Changelog for the datasheet

SPE-23-8-355 – TMJU5943-7B50NL

Revision: A (Original First Release)

Date:	2024-01-01
Notes:	
Author:	Javier Vasena

Previous Revisions



www.taoglas.com

