

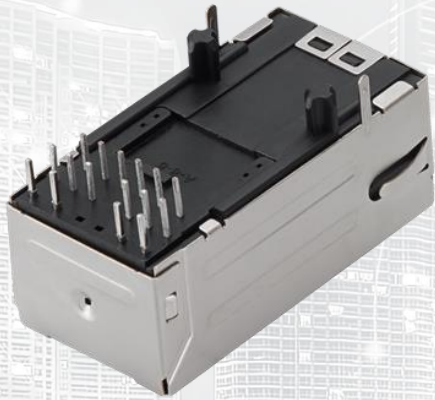

TAOGLAS®



Datasheet

RJ45 ICM 10G Base-T

Part No:
TMJY611DGDZ4NL

Description:

RJ45 connector with integrated magnetics 10G Base-T.
Single Port Tab-UP with THT mount and LEDs.

Features:

- Long Body
- 3Wire + Transformer
- Shielded EMI Finger
- Industrial grade
- 30 μ " gold
- RoHS compliant

1. Introduction	3
2. Specifications	4
3. Mechanical	5
4. Electrical	6
5. Packaging	7
<hr/>	
Changelog	8

Taoglas makes no warranties based on the accuracy or completeness of the contents of this document and reserves the right to make changes to specifications and product descriptions at any time without notice. Taoglas reserves all rights to this document and the information contained herein. Reproduction, use or disclosure to third parties without express permission is strictly prohibited.



1. Introduction



Featuring a popular footprint and compatible package to industry RJ45 Integrated Connectors standards, the Taoglas TMJY611DGDZ4NL is an RJ45 Integrated Connector 10G Base-T with Shielded EMI Finger and long body design for Industrial environments.

Typical Applications Include:

- Industrial Automation
- Hubs
- Routers
- Switches
- Wireless Access Points

Taoglas Magnetics offer an extensive product line of RJ45 Integrated Connectors designed for commercial and industrial grade applications, supporting 10/100 Base-T (Atmos100 Series) and 1G Base-T (Atmos1000 series). These surface mount or through-hole components provide reliable performance and maintain signal integrity that meets IEEE 802.3 standards, and they are UL certified. The Power over Ethernet options are also available including PoE, PoE+ and PoE++.

The majority of Taoglas RJ45 ICMs are manufactured with fully automated winding, assembly & testing to ensure consistent performance, quality and reliability while ensuring cost competitiveness for its customers. These products are fully compliant with the REACH and RoHS directive, and compatible with all major PHY vendors.

For customized products or support with integration, contact your regional Taoglas customer support team for further information.

2. Specifications

Electrical Performance @25°C	
OCL (100KHz/0.1V@8mA)	110uH MIN
Turns Ratio (±5%)	1CT: 1CT
Insertion Loss (dB MAX)	-3.0dB (100kHz)
	-2.0dB (1-400MHz)
Return Loss (dB MIN)	-22dB (1-100MHz)
	-22 + 20.75Log(f/100MHz) dB (100-500MHz)
Cross talk (dB MIN)	-34dB (1MHz)
	-23dB (350MHz)
	-23dB (500MHz)
CMR (dB MIN)	-30dB (1-40MHz)
	-28dB (40-100MHz)
	-26dB (100-500MHz)
CDMR (dB MIN)	-30dB (1-250MHz)
	-22dB (250-500MHz)
HI-POT (Pri to Sec)	2250VDC/0.5mA/2S

Environmental Specifications	
Operating Temperature	-40°C TO +85°C

Material Specifications	
Housing	PA66 Black UL94 V-0
Insert	PA66 Black UL94 V-0
Shield	Brass
Shield Plating	Nickel
Contact	Phosphor Bronze
Contact Plating	Gold in contact area Thickness = 30µ" min.
Peak soldering temp.	260°C Max, 10 s Max

Compliance	
RoHS Compliant	

Storage requirements	
Humidity	MSL - 1
Storage Temperature	-40°C TO +85°C

3. Mechanical

3.1 Mechanical Drawings

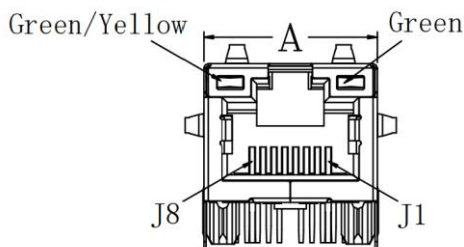

Front View

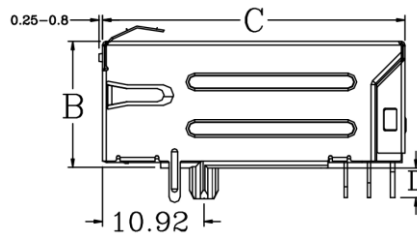

Left View

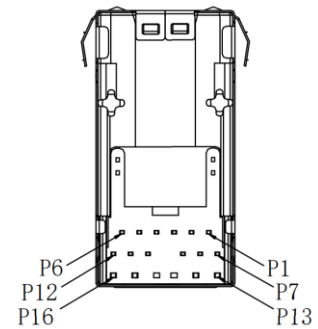

Bottom View

Mechanical Specifications	
Height	13.61 mm
Width	16.31 mm
Depth	32.57 mm
Mounting Style	Through Hole (THT)
Mounting Angle	Right Angle

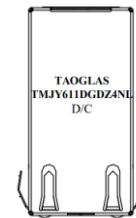

Top Side View

UNIT : mm

- A = 16.31
- B = 13.61
- C = 32.57
- D = 3.17

Dimensions are in millimeters with the following tolerances: X.XX = ±0.25

3.2 PCB Layout

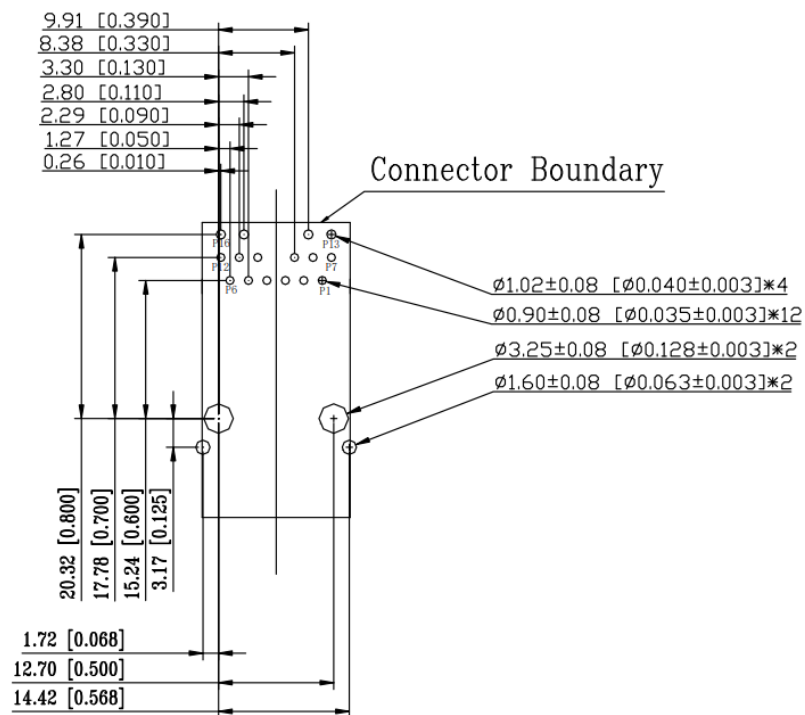

Suggested PCB Layout (Top View)

Dimensions are in millimeters with the following tolerances: X.XX = ±0.10

4. Electrical

4.1 Electrical Drawings

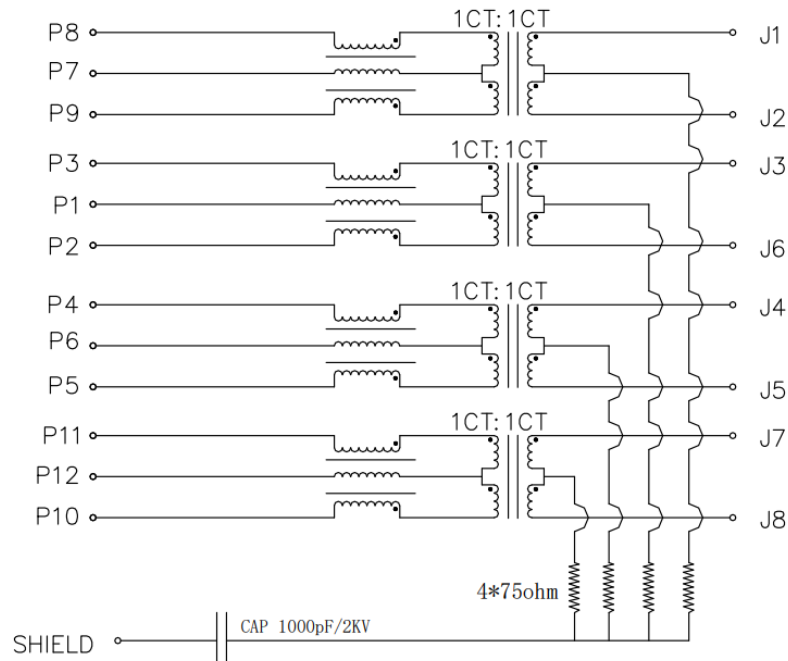

LED Electrical Specification

Standard LED	Wavelength (nm)	V _F (max)	TYP
Green	565	2.4v	2.2v
Yellow	590	2.4v	2.1v

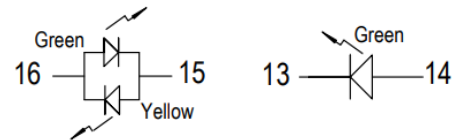

4.2 Profile of Wave Solder

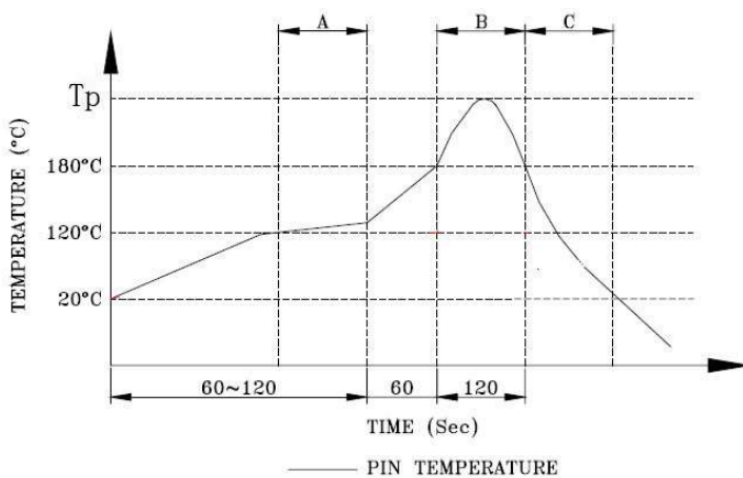

SUGGESTED WAVE SOLDER CURVE

1. Peak temperature(T_p) : 250 ± 10°C
2. Peak temperature(T_p) time : 5sec max

A. Preheating B. Soldering C. Gradual Cooling

5. Packaging

5.1 SPQ

60 pcs/tray

Tray (mm): 296x178x34

Weight: 550gr

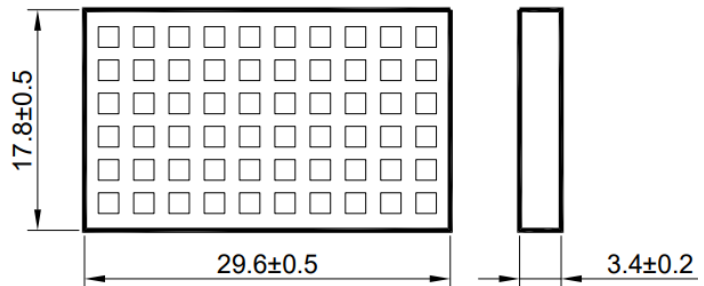

1 Carton = 14 trays = 840 pcs

Carton dimensions: 380*325*290mm

Carton Weight: 11kg



5.2 Label

Taoglas Limited	
P/N NO: XXXXXXXX	
QYT: XXX PCS	DC: XXXX
DATE: XXXX-XX-XX	

SPQ Label (8x4cm)

Taoglas Limited	
P/N NO: XXXXXXXX	
PO: XXXXXXXX	B/N: XXXXXXXX
QYT: XXX PCS	DC: XXXX
DATE: XXXX-XX-XX	

Carton Label (8x4cm)

Changelog

Changelog for the datasheet

SPE-23-8-154 – TMJY611DGDZ4NL

Revision: A (Original First Release)

Date:	2023-07-01
Notes:	
Author:	Javier Vasena

Previous Revisions



www.taoglas.com

