



# TAOGLAS®



# Datasheet

## 2.4GHz Cyclops

**Part No:**  
WM.24.A.305111

### **Description:**

Cyclops 2400~2500MHz Wall Mount Flexible Whip Antenna

### **Features:**

- Wi-Fi® 2.4GHz Whip Antenna
- Wall-Mount Bracket
- Flexible Inner Steel Core Whip
- IP65 Waterproof
- SMA(M) ST connector
- 3m Low loss CFD-200 cable
- Cable is hidden internally in the Bracket
- RoHS & REACH Compliant

|                            |    |
|----------------------------|----|
| 1. Introduction            | 3  |
| 2. Specifications          | 4  |
| 3. Antenna Characteristics | 6  |
| 4. 2D Radiation Patterns   | 8  |
| 5. 3D Radiation Patterns   | 10 |
| 6. Mechanical Drawing      | 11 |
| 7. Installation            | 12 |
| 8. Packaging               | 13 |
| <hr/>                      |    |
| Changelog                  | 14 |

Taoglas makes no warranties based on the accuracy or completeness of the contents of this document and reserves the right to make changes to specifications and product descriptions at any time without notice. Taoglas reserves all rights to this document and the information contained herein.

Reproduction, use or disclosure to third parties without express permission is strictly prohibited.

Copyright © Taoglas Ltd.

Ireland & USA  
ISO 9001:2015  
Certified



Taiwan  
ISO 9001:2015  
Certified



# 1. Introduction



The WM.24 is a 2.4GHz flexible whip antenna with a screw mounted wall mount L bracket. The radiation pattern is omni-directional in the azimuth, allowing for large coverage range in typical indoor or outdoor installations. Peak gain, average gain/efficiency are both optimized to provide extended coverage area in the azimuth (horizontal direction), while also maintaining an Omni-directional pattern for close in reception/transmission.

Typical Applications include:

- Remote Monitoring
- Connected Enterprise
- Agriculture
- Security

This antenna provides high efficiency while fixed on the L-bracket. The whip is made up of a flexible inner steel core covered by TPU, so it is extremely resistant to collisions and maintaining its original shape and RF performance. The whip and the internal connection to the bracket is IP65 rated waterproof. The whip can be removed by unscrewing.

The bracket allows complete concealment of the cable for a more secure integration and cleaner installation. The cable can also be routed out of the back wall of the bracket into the interior of the mounting wall for added security against vandalism. The standard version comes with 3 metres of extremely low loss CFD-200 cable (0.3dB against 0.7dB for RG-58) to allow for flexibility of placement. The cable and connector can be completely customized. The whip itself can also be changed for different frequency bands or gain requirements.

Contact your regional Taoglas Customer Support Team for more information or installation guidelines.

## 2. Specifications

| Cellular                 |                  |
|--------------------------|------------------|
| Frequency (MHz)          | 2400~2500MHz     |
| <b>Peak Gain (dBi)</b>   |                  |
| 30cm                     | 2.97             |
| 1m                       | 2.57             |
| 2m                       | 1.97             |
| 3m                       | 1.37             |
| 5m                       | 0.77             |
| <b>Average Gain (dB)</b> |                  |
| 30cm                     | -1.93            |
| 1m                       | -2.33            |
| 2m                       | -2.93            |
| 3m                       | -3.53            |
| 5m                       | -4.13            |
| <b>Efficiency (%)</b>    |                  |
| 30cm                     | 64.18            |
| 1m                       | 58.53            |
| 2m                       | 50.97            |
| 3m                       | 44.40            |
| 5m                       | 38.67            |
| <b>Return Loss(dB)</b>   | <-10             |
| <b>Impedance</b>         | 50Ω              |
| <b>Polarization</b>      | Linear           |
| <b>Radiation Pattern</b> | Omni-Directional |
| <b>Input Power</b>       | 10W              |

| Mechanical            |                            |
|-----------------------|----------------------------|
| Antenna Height        | 307mm                      |
| Bracket Dimensions    | 118 x 32 mm                |
| Cable                 | 3m CFD-200                 |
| Connector             | SMA(M) ST                  |
| Antenna Casing        | ABS                        |
| Bracket Casing        | PC                         |
| Weight                | 330g                       |
| Environmental         |                            |
| Waterproof Rating     | IP65                       |
| Operation Temperature | -40°C to 85°C              |
| Humidity              | Non-condensing 65°C 95% RH |

### 3. Antenna Characteristics

#### 3.1 Return Loss

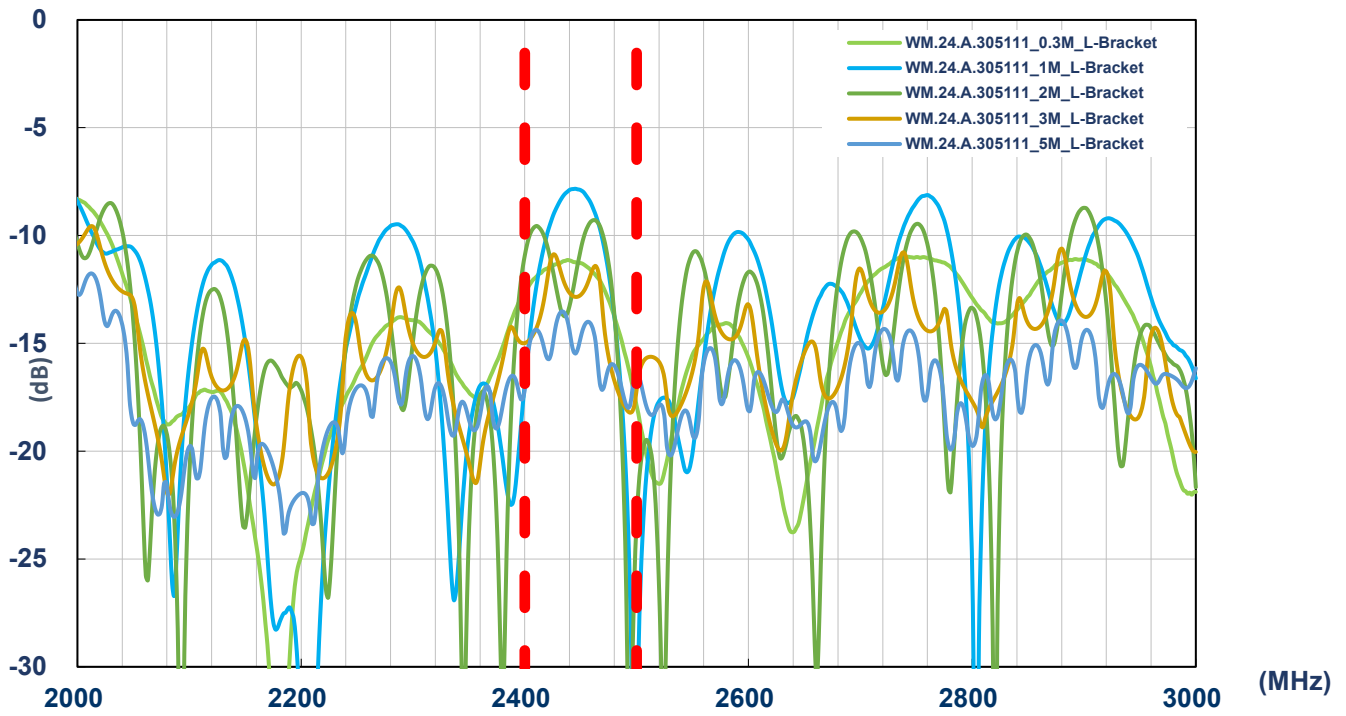

#### 3.2 Efficiency

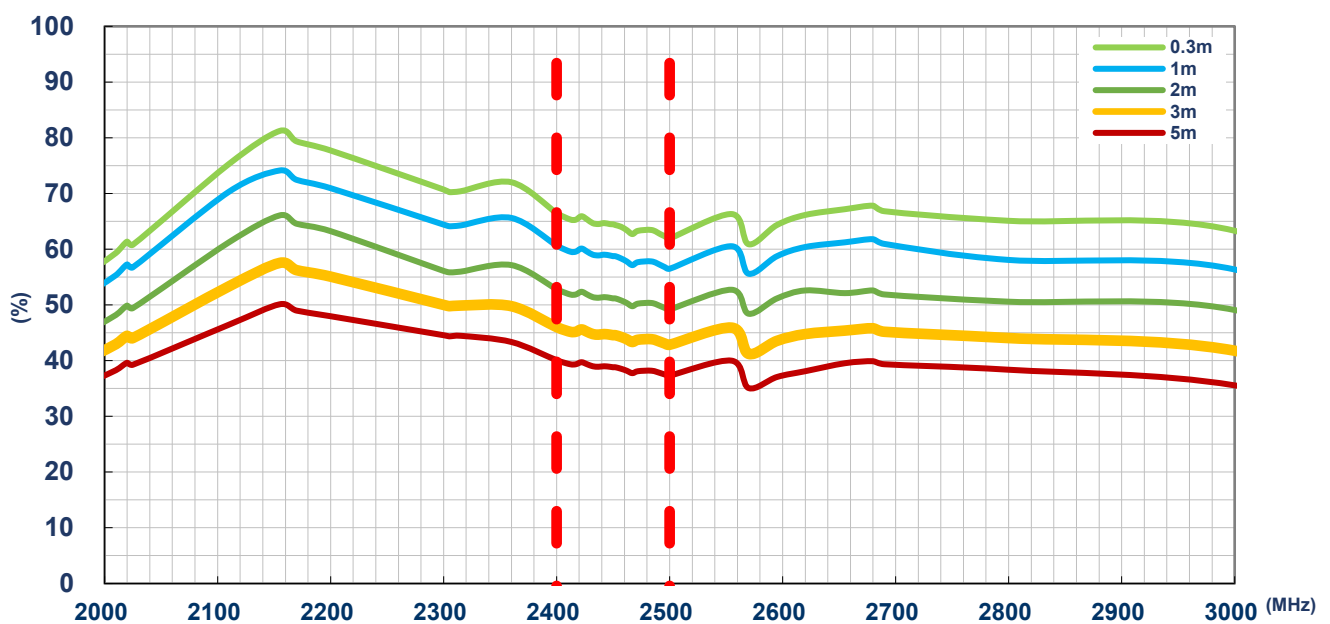

### 3.3 Average Gain

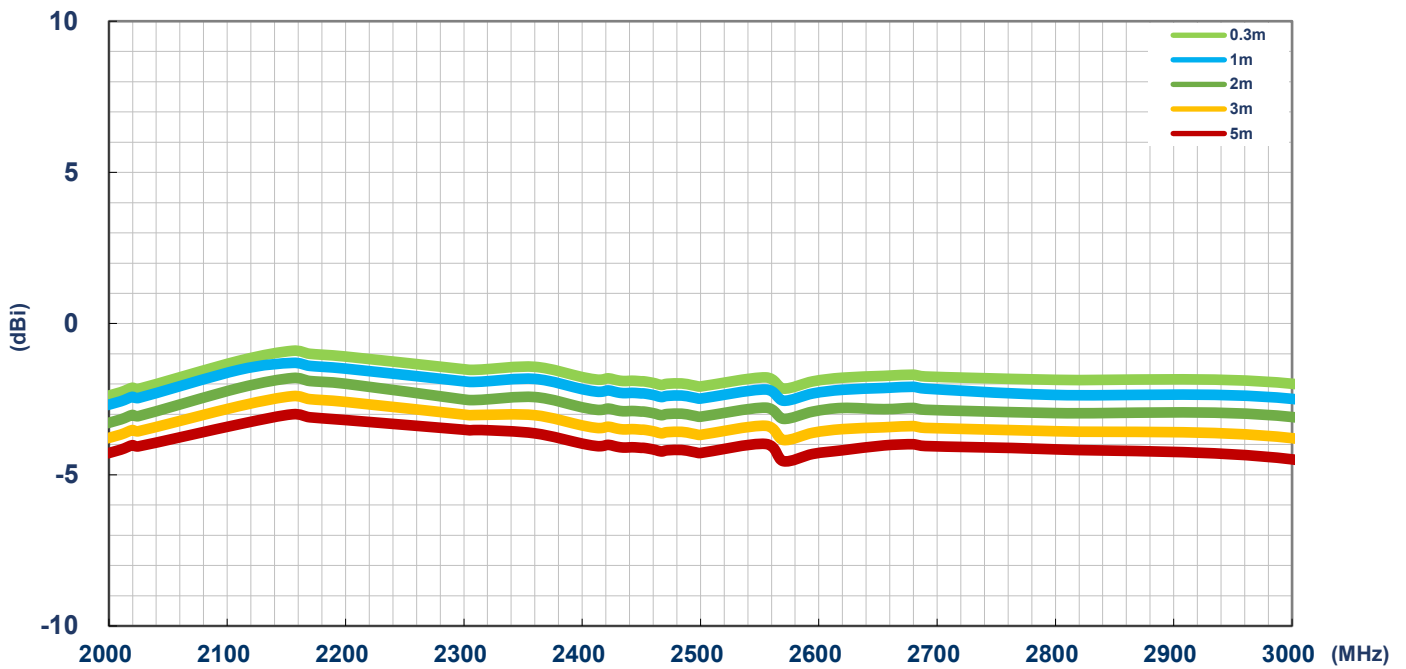

### 3.4 Peak Gain

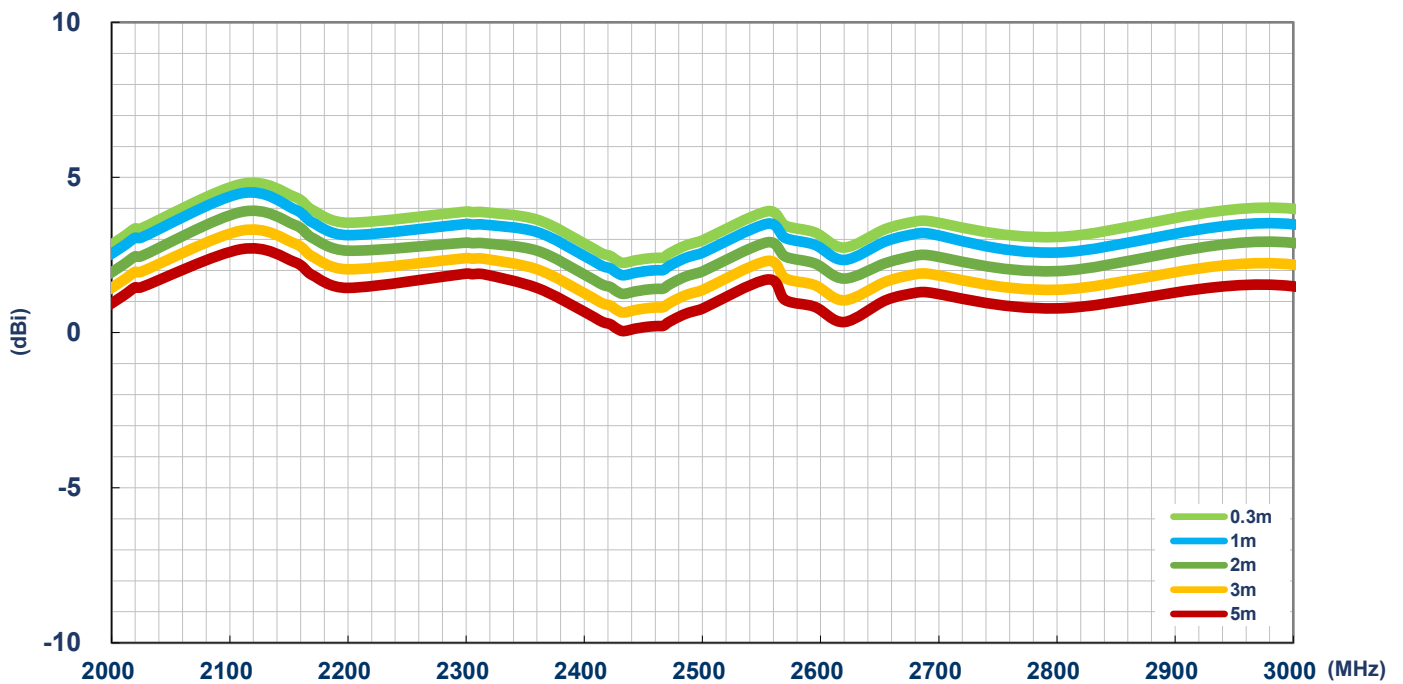

## 4. 2D Radiation Patterns

### 4.1 Test Setup



Free space



XY Plane

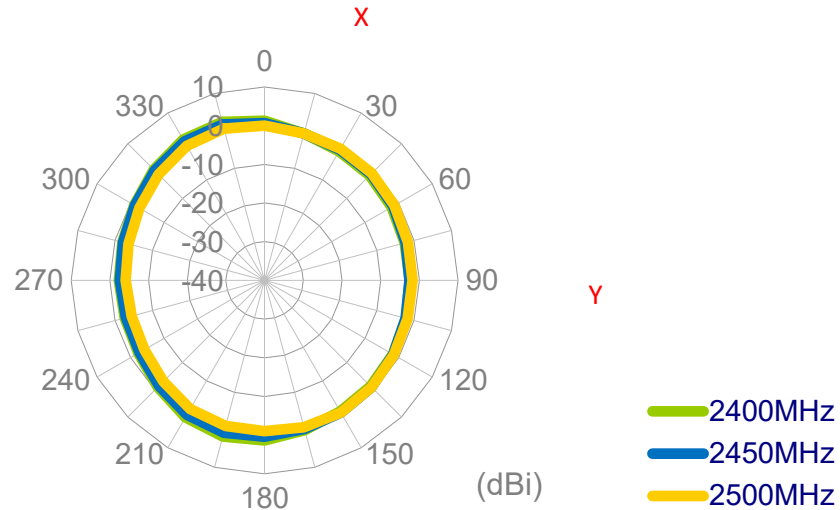

XZ Plane

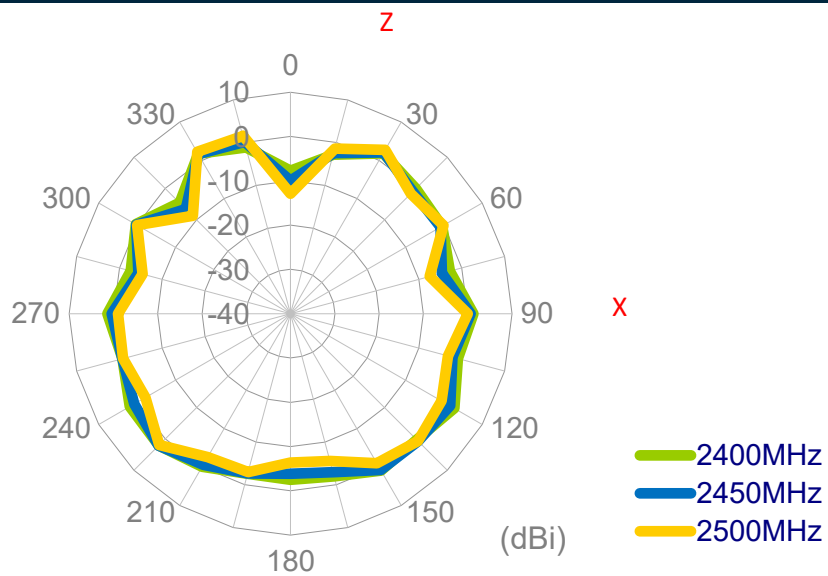

YZ Plane

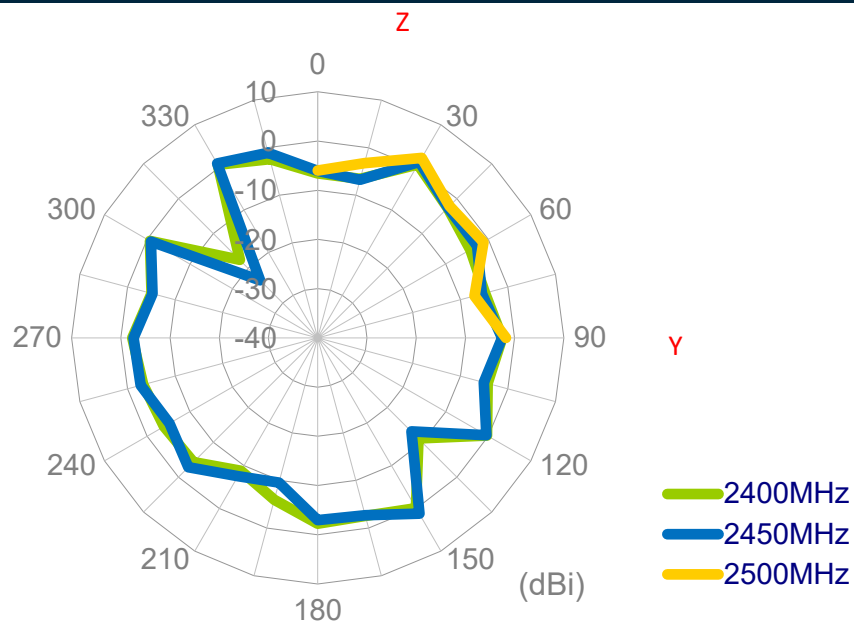

## 5. 3D Radiation Patterns

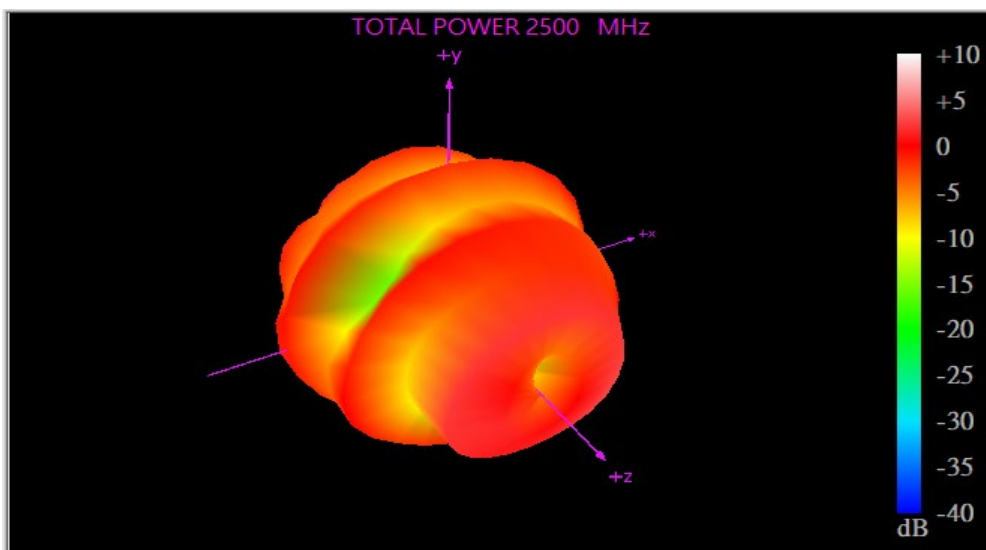
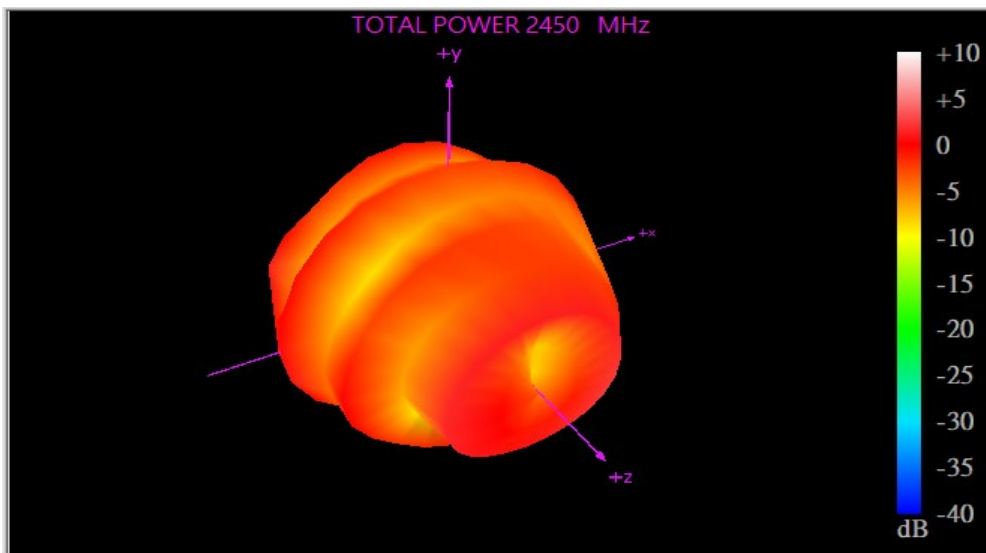
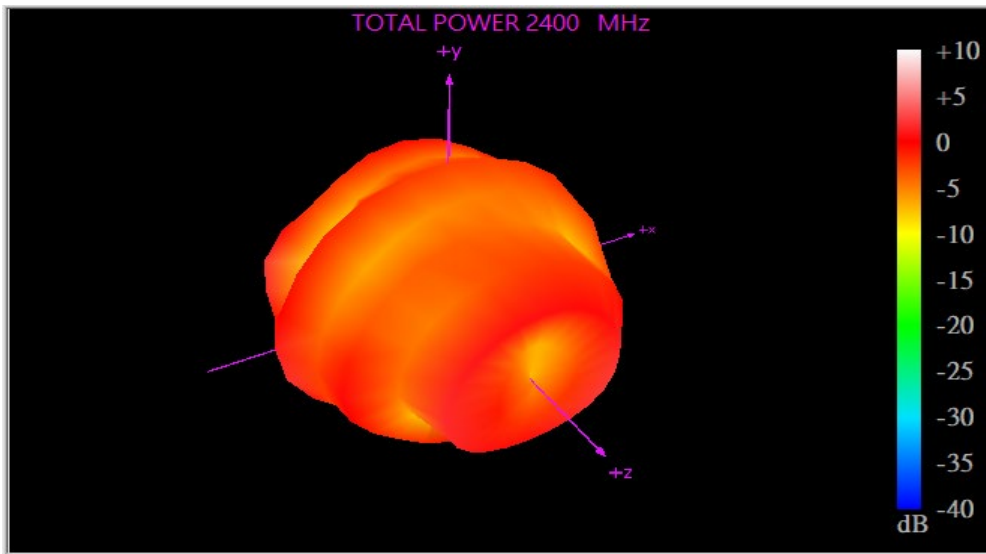

# 6. Mechanical Drawing (Units: mm)

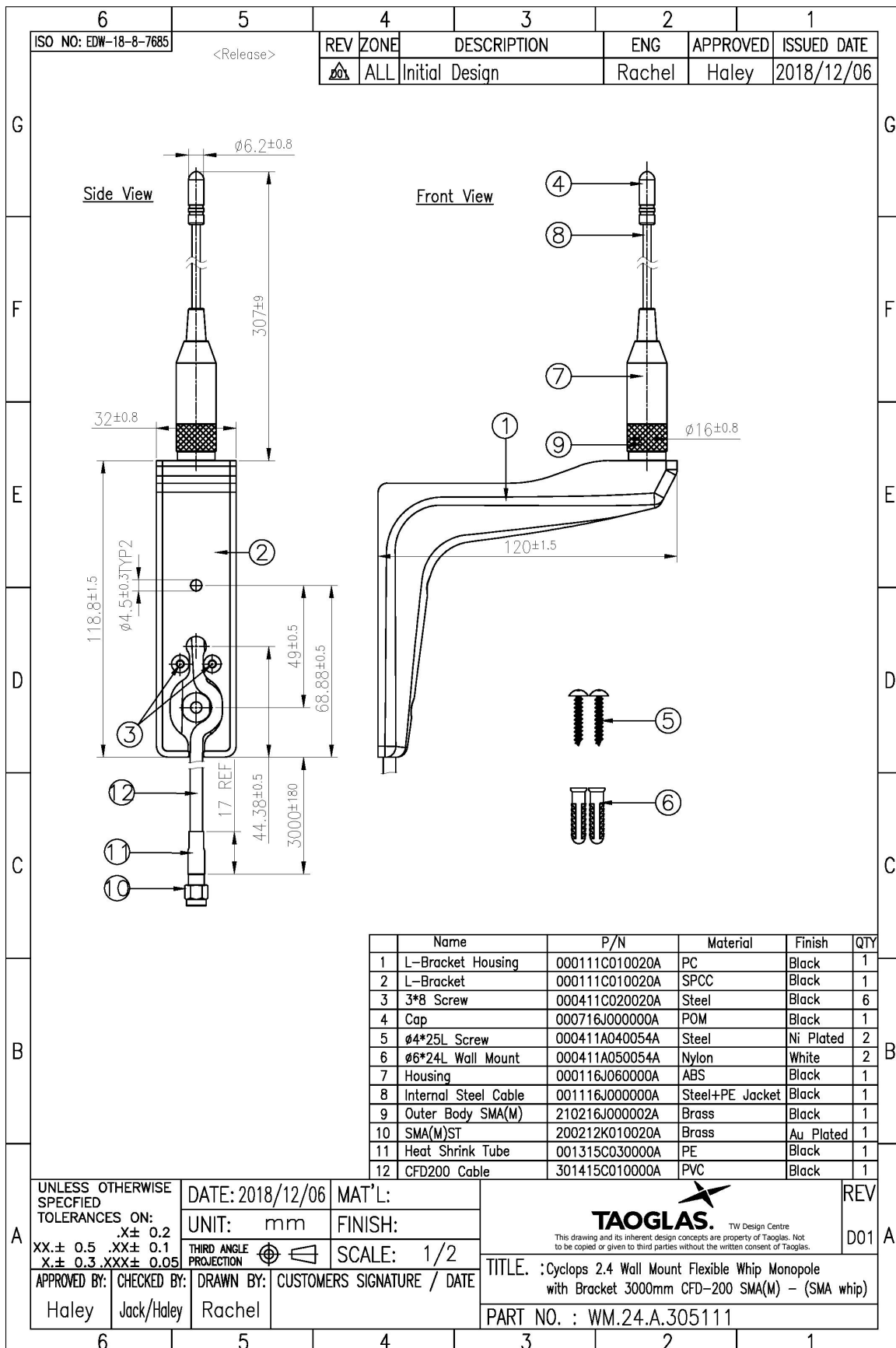

## 7. Installation

### Wall Mounting

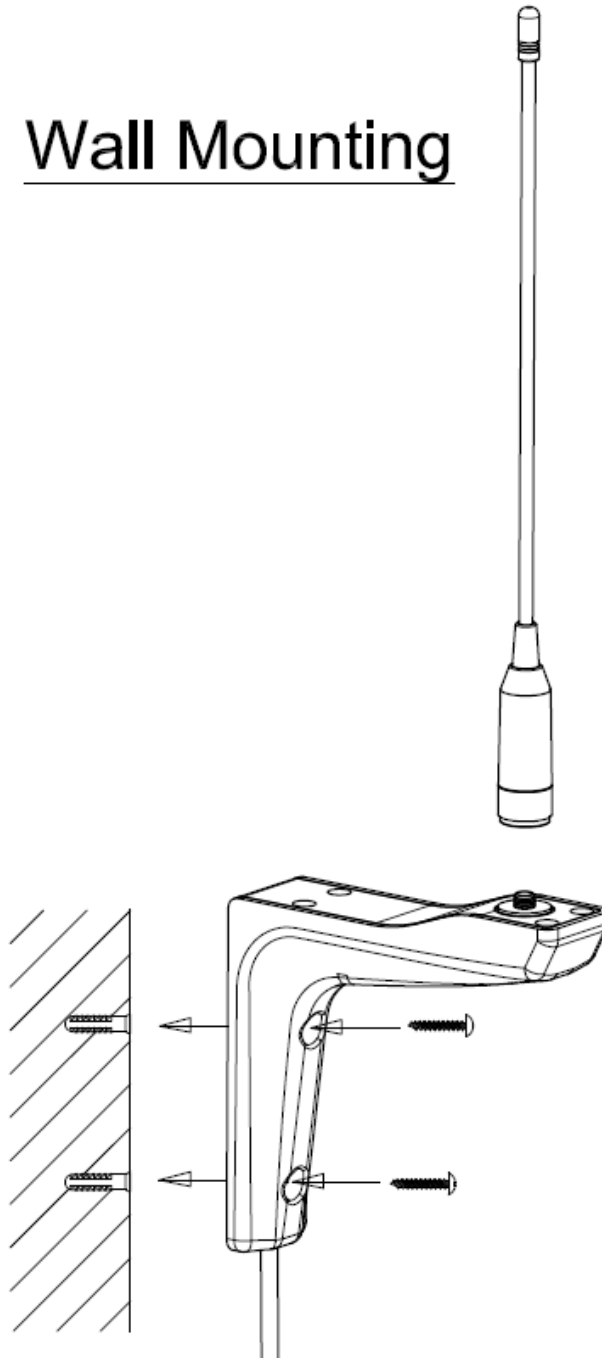

## 8. Packaging

1pcs WM.24.A.305111 per PE Bag  
 Bag Dimensions: 380\*220mm  
 Weight: 360g

25pcs WM.24.A.305111 per carton  
 Bag Dimensions: 450\*360\*280mm  
 Weight: 2.9Kg

Pallet Dimensions: 1100\*1120\*1230mm  
 24 Cartons per Pallet  
 6 Cartons per Layer  
 4 Layers

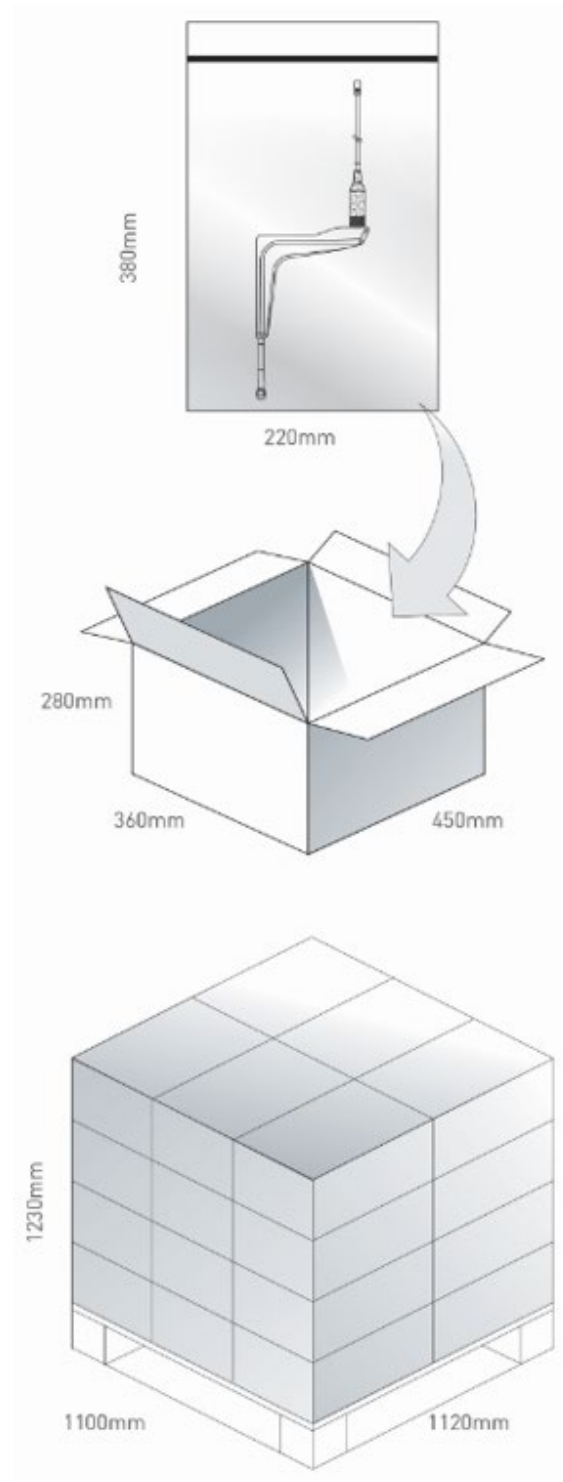

Changelog for the datasheet

**SPE-19-8-085 – WM.24.A.305111**

**Revision: A (Original First Release)**

|         |             |
|---------|-------------|
| Date:   | 2019-06-21  |
| Notes:  |             |
| Author: | Jack Conroy |

**Previous Revisions**

|  |  |
|--|--|
|  |  |
|  |  |
|  |  |
|  |  |
|  |  |



**TAOGLAS**®

[www.taoglas.com](http://www.taoglas.com)

