

Specification

Part No.	:	WMA.328.A.001
Product Name	:	Taoglas Pivot – 3 in 1, 2.4/5.8GHz Wi-Fi® MIMO Desk, Wall or Magnetic Mount Antenna
Features	:	3 * 2.4/5.8GHz Wi-Fi® MIMO Desk, Wall and Magnetic Mounting Options RHCP Patch Design 16 Position Adjustable Housing High Gloss ASA Enclosure Dimension: 95x95x124mm Connectors: SMA(F) RoHS compliant



1. Introduction

The Taoglas Pivot WMA.328.A.001 is a 3*Wi-Fi® MIMO dual-band patch array antenna incorporating three separately fed antennas in a single housing. This compact Wi-Fi® solution ensures a strong connection and fast transfer speeds. The RHCP circularly polarized patch design helps preserve received signal quality in rich isotropic multipath (RIMP) environments such as building interiors, where reflected signals can be a significant source of interference. With an adjustable head and quick and easy, compact set-up, the WMA.328 is an ideal solution to address a slow or dropping Wi-Fi® signals.

Many module manufacturers specify peak gain limits for any antennas that are to be connected to that module. Those peak gain limits are based on free space conditions. In practice, the peak gain of an antenna tested in free space can degrade by at least 1 or 2 dBi when put inside a device. So ideally you should go for a slightly higher peak gain antenna than mentioned on the module specification to compensate for this effect, giving you better performance.

Upon testing of any of our antennas with your device and a selection of appropriate layout, integration technique, or cable, Taoglas can make sure any of our antennas' peak gain will be below the peak gain limits. Taoglas can then issue a specification and/or report for the selected antenna in your device that will clearly show it complying with the peak gain limits, so you can be assured you are meeting regulatory requirements for that module.

For example, a module manufacturer may state that the antenna must have less than 2 dBi peak gain, but you don't need to select an embedded antenna that has a peak gain of less than 2 dBi in free space. This will give you a less optimized solution. It is better to go for a slightly higher free space peak gain of 3 dBi or more if available. Once that antenna gets integrated into your device, performance will degrade below this 2 dBi peak gain due to the effects of GND plane, surrounding components, and device housing. If you want to be absolutely sure, contact Taoglas and we will test.

Choosing a Taoglas antenna with a higher peak gain than what is specified by the module manufacturer and enlisting our help will ensure you are getting the best performance possible without exceeding the peak gain limits.

Cable and connector assemblies for this antenna are customizable and are available upon request through our Cable Builder at <https://www.taoglas.com/cable-builder/>

For further information or support, contact your regional Taoglas sales office.



2. Specification

ELECTRICAL*		
Frequency (MHz)	2400~2500	4900~5850
Efficiency (%)		
MIMO 1	39.46	36.80
MIMO 2	38.10	35.41
MIMO 3	35.83	37.23
Average Gain (dBi)		
MIMO 1	-4.04	-4.34
MIMO 2	-4.19	-4.51
MIMO 3	-4.46	-4.29
Peak Gain (dBi)		
MIMO 1	2.13	4.13
MIMO 2	1.90	3.70
MIMO 3	2.28	4.15
Return Loss	< -5	
Impedance	50Ω	
Polarization	RHCP	
MECHANICAL		
Dimensions (mm)	95.19*95.19*124.09	
Housing Material	ASA	
Shaft Material	PC	
Connector	SMA(F)BK ST	
Weight	152g	
Magnetic Pull Force	Horizontal : 1.0 Kgf : Vertical : 4.5 Kgf	
ENVIRONMENTAL		
Operating and Storage Temperature	-40°C to +85°C	
Humidity	Non-condensing 65 C 95% RH	

* Measurements taken in free space

3. Antenna Characteristics

3.1 Return Loss

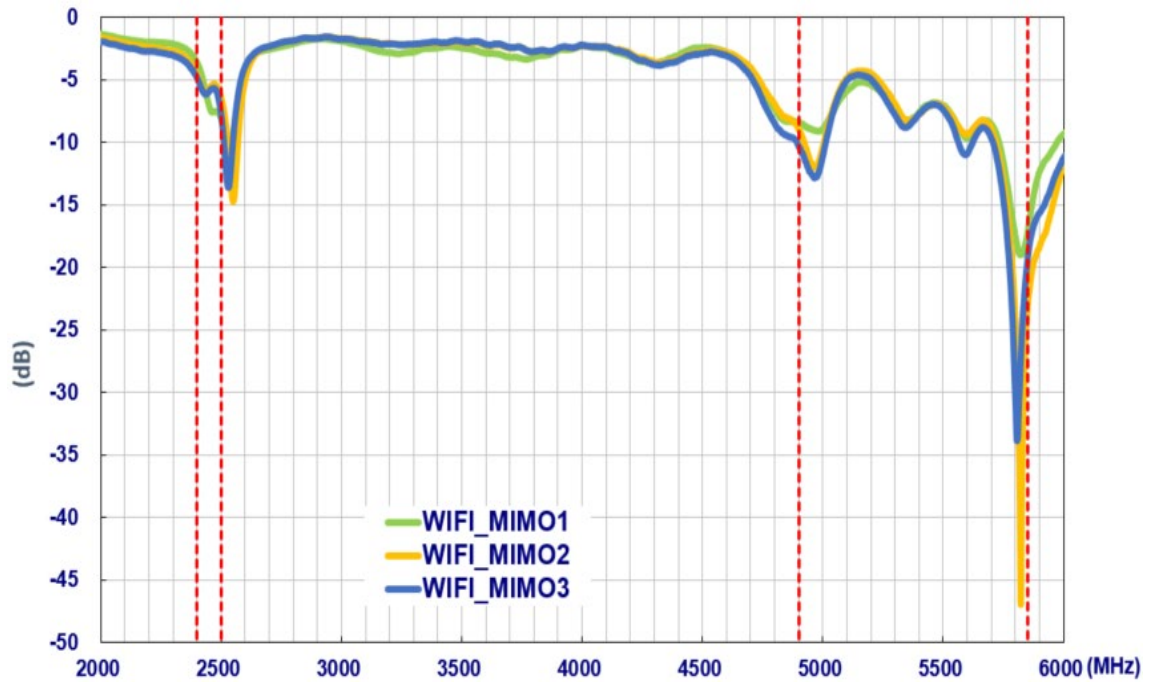

3.2 Envelope Correlation Coefficient (ECC)

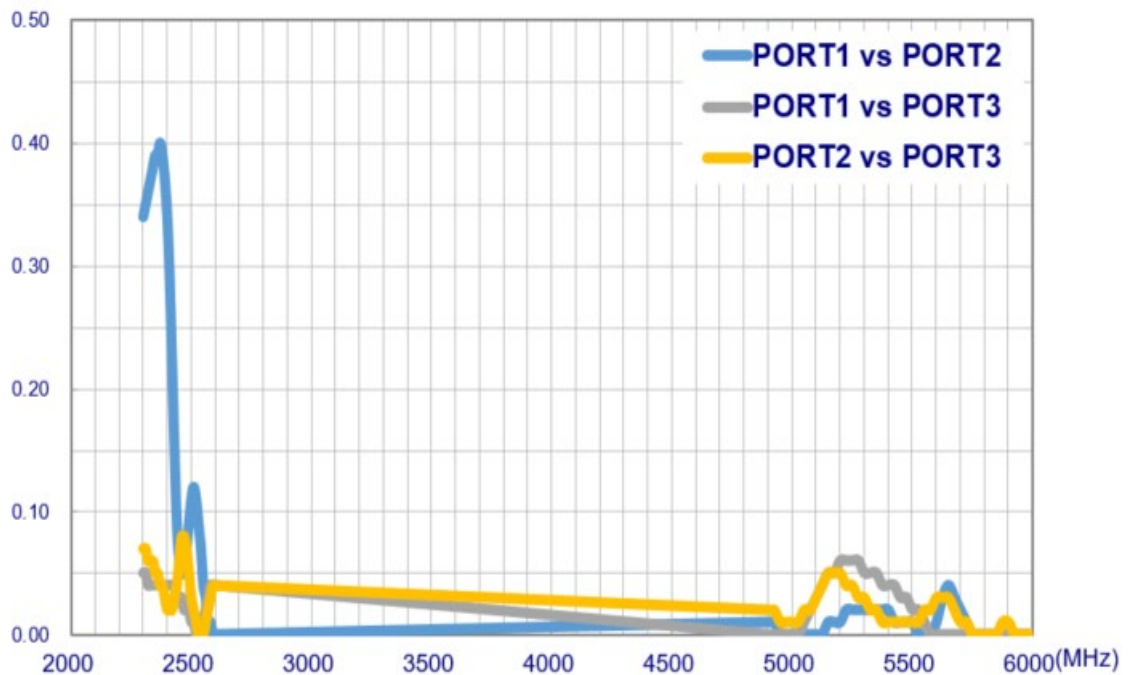

3.3 Isolation

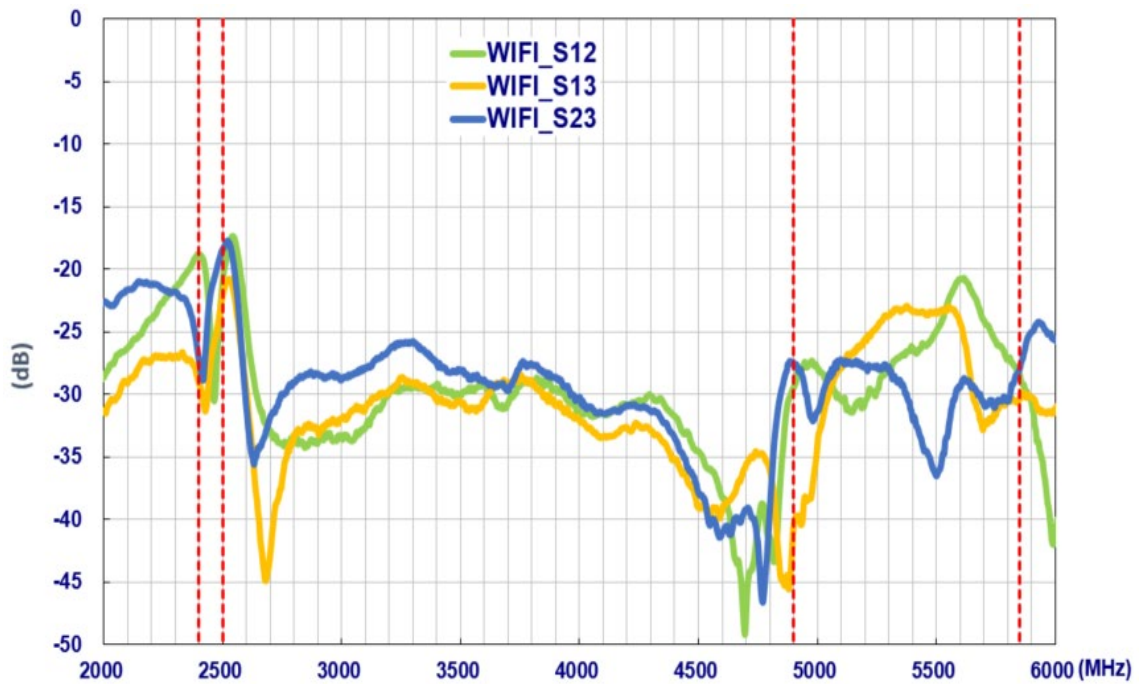

3.4 Efficiency

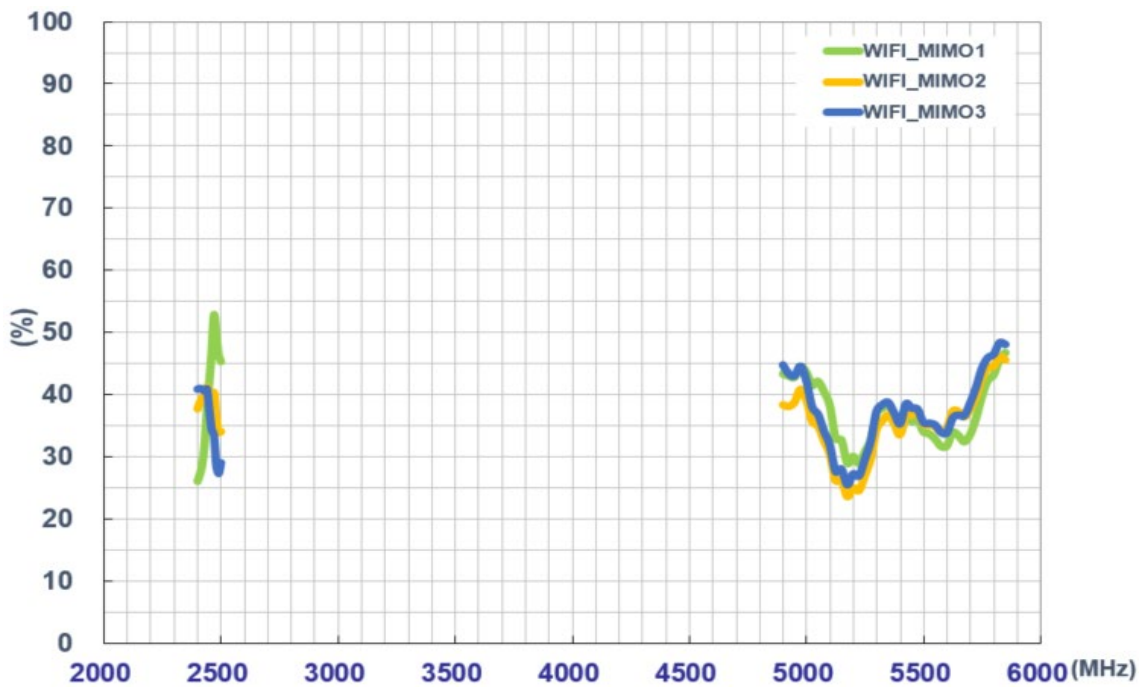

3.5 Average Gain

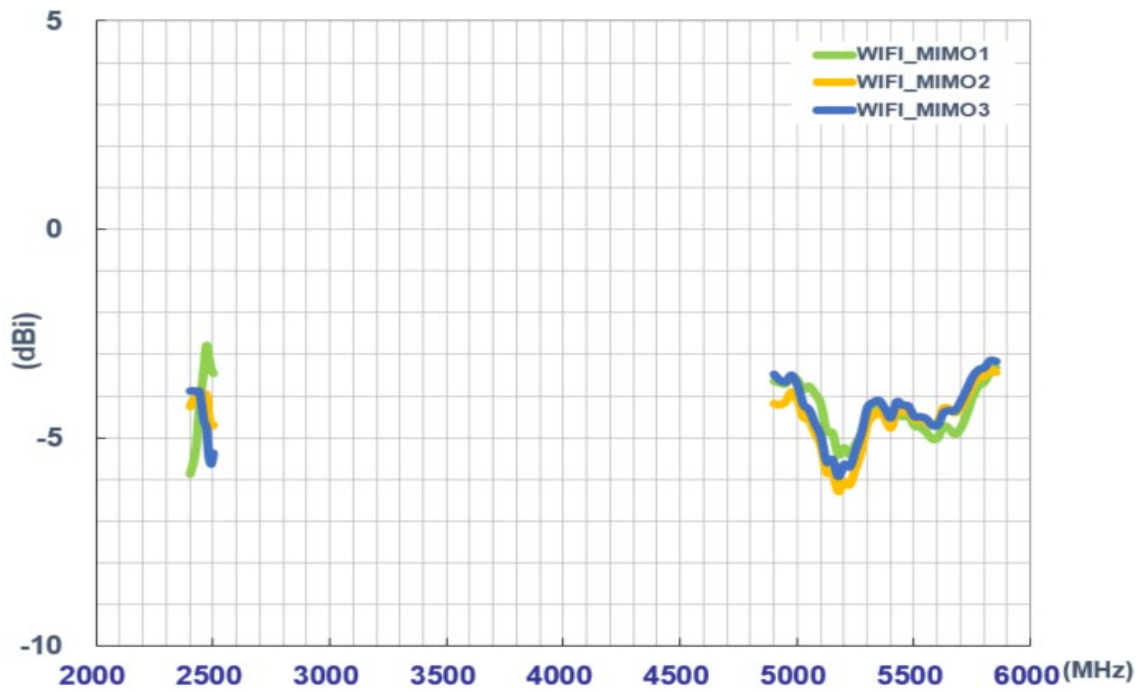

3.6 Peak Gain

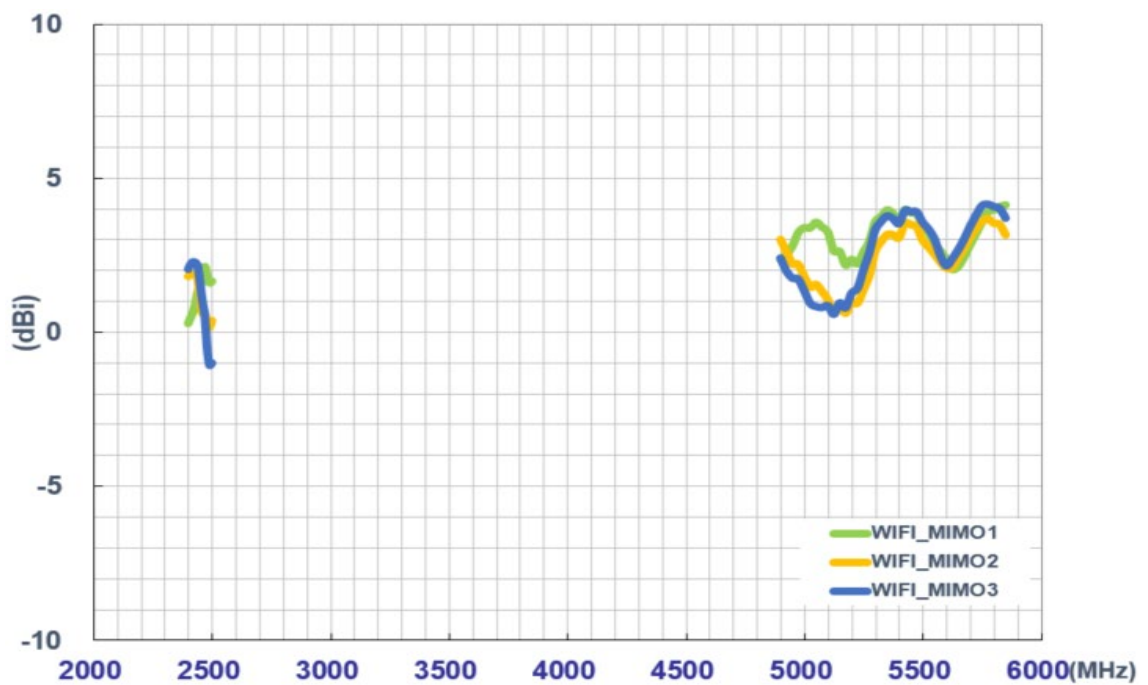

4. Antenna Radiation Patterns

4.1 Antenna Setup (Antenna Test Setup in Anechoic Chamber)

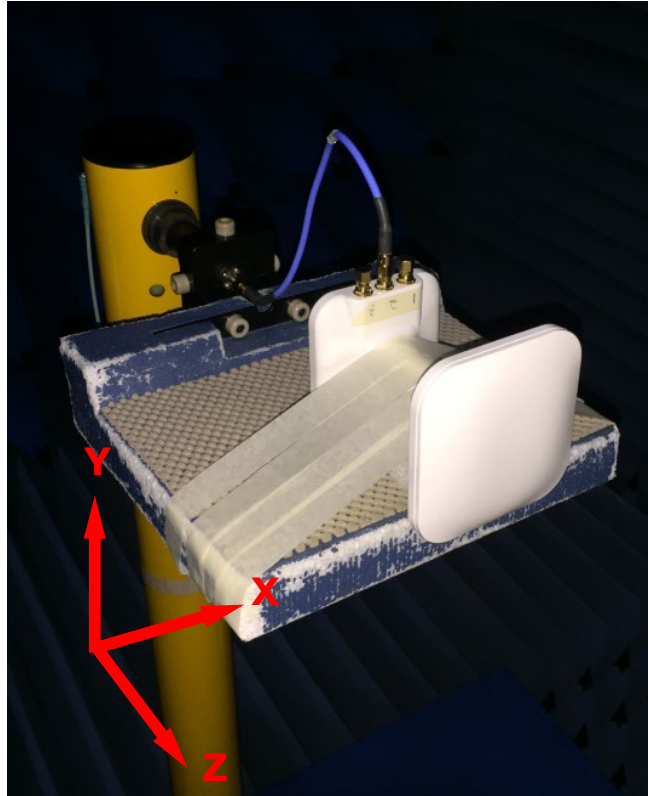

4.2 2D Radiation Patterns

4.2.1 Wi-Fi MIMO 1

XY Plane

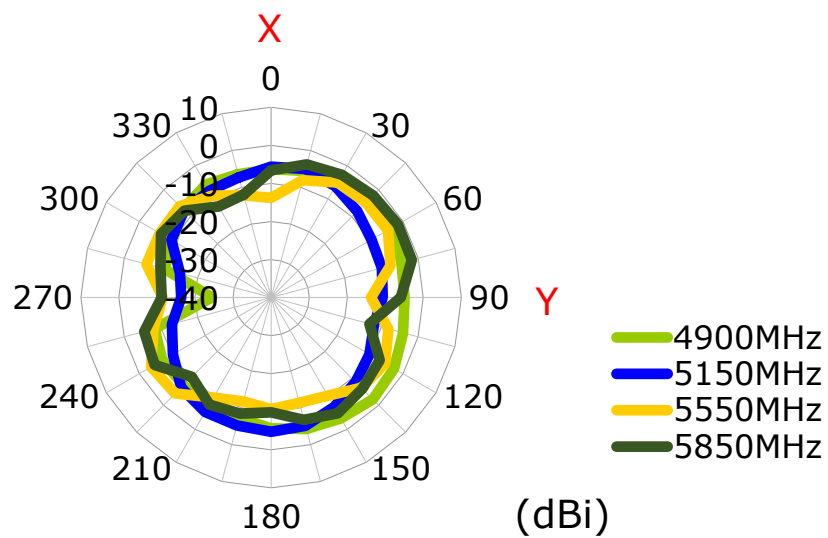
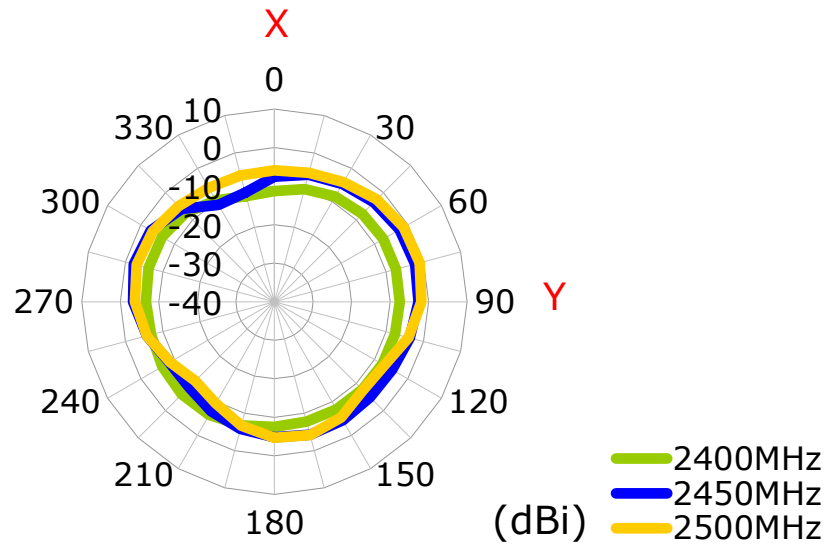

XZ Plane

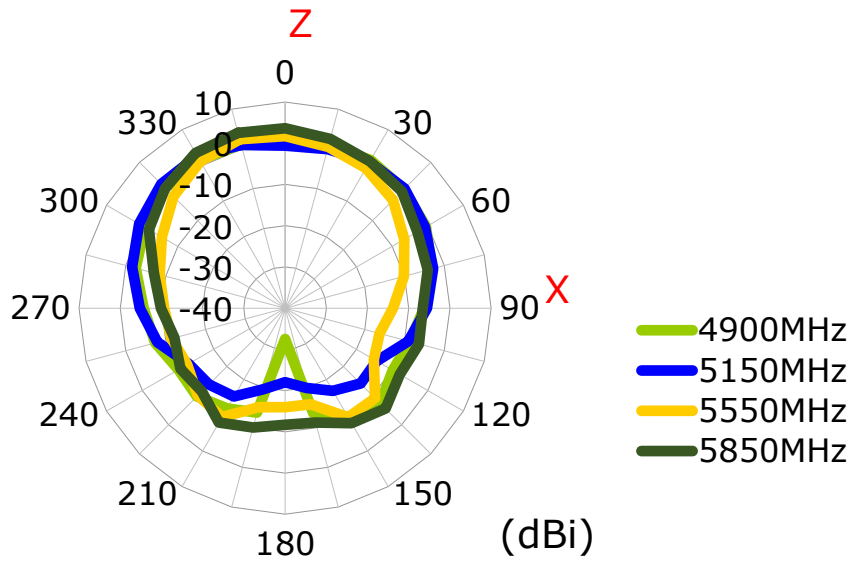
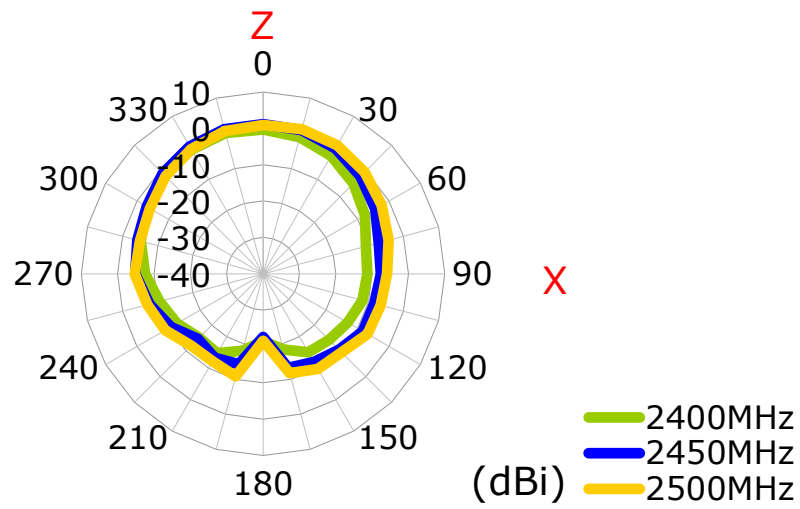

YZ Plane

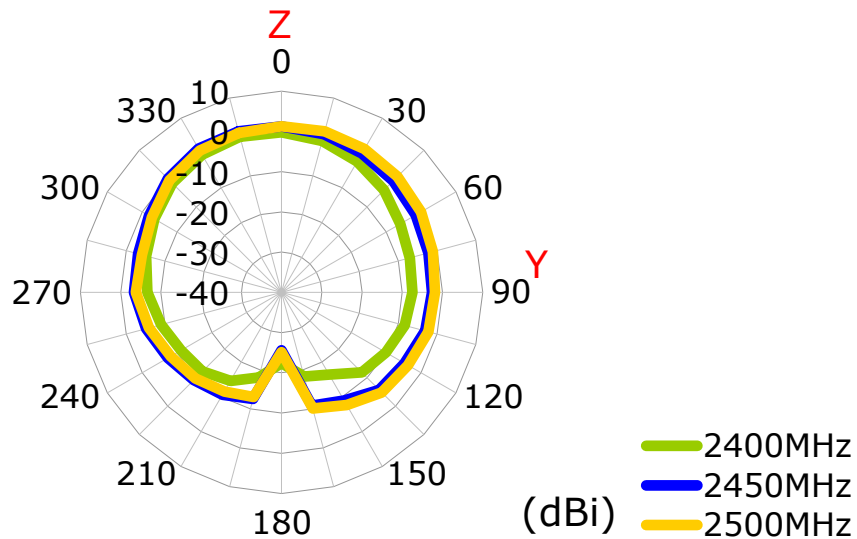

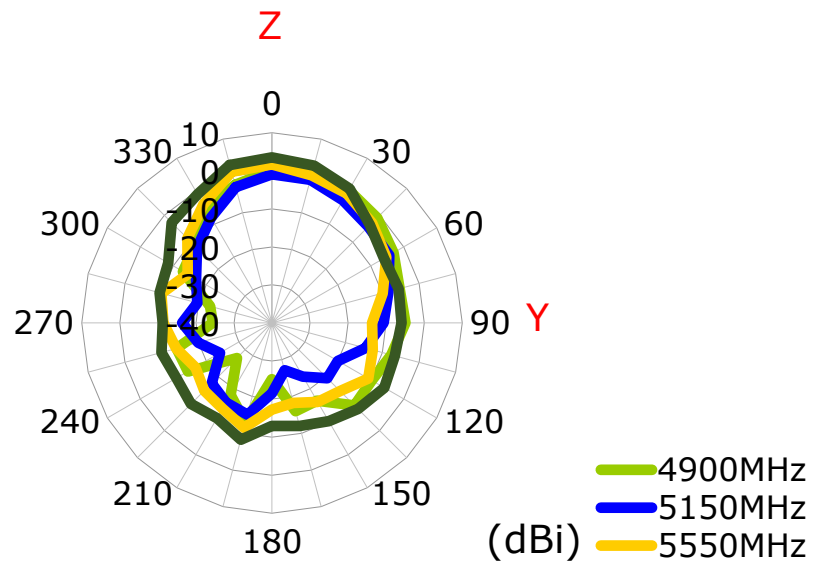

4.2.2 Wi-Fi MIMO 2

XY Plane

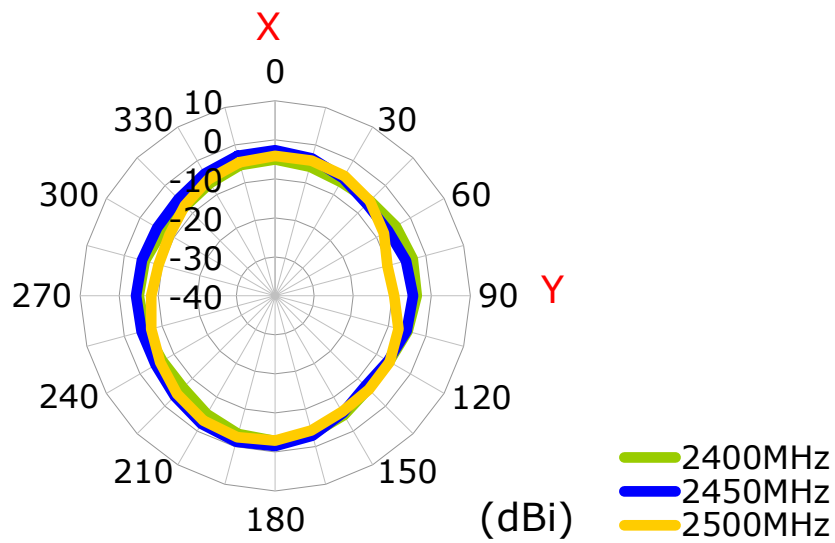

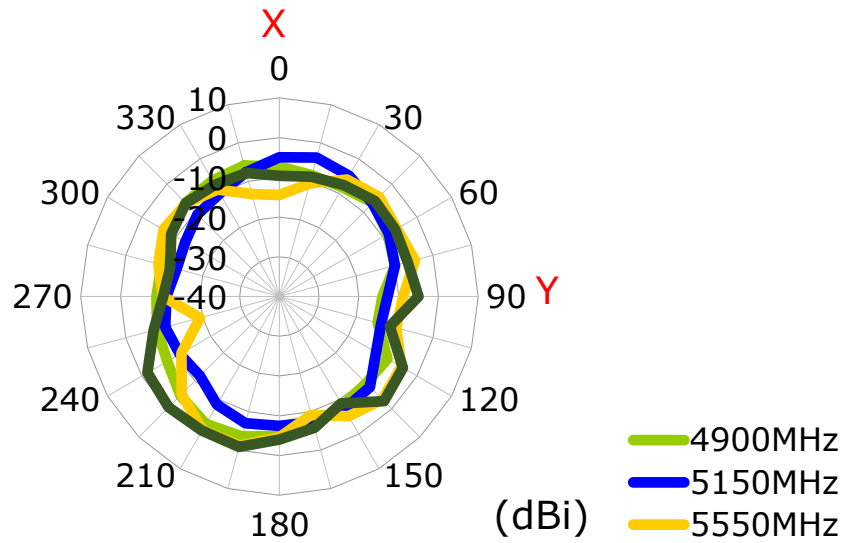

XZ Plane

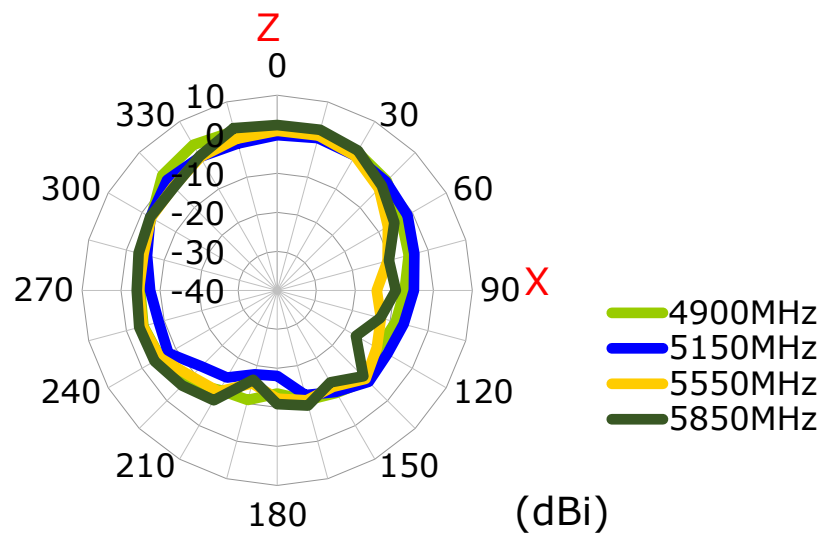
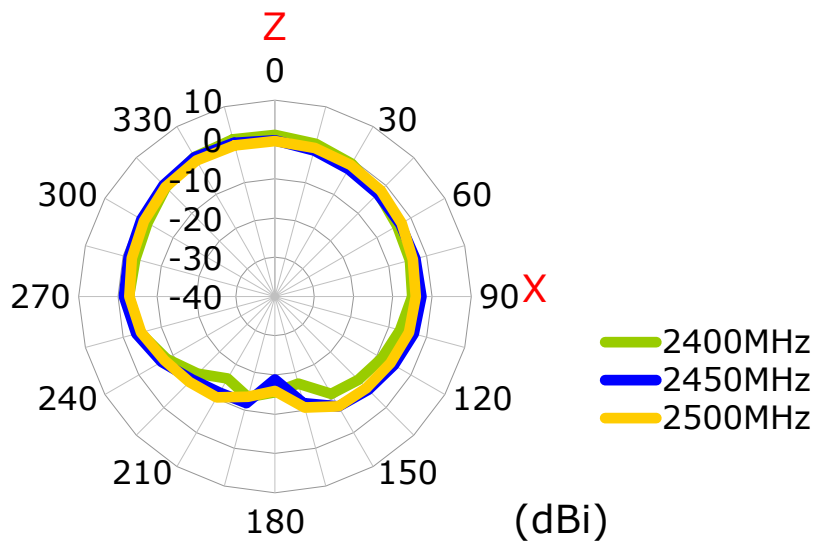

YZ Plane

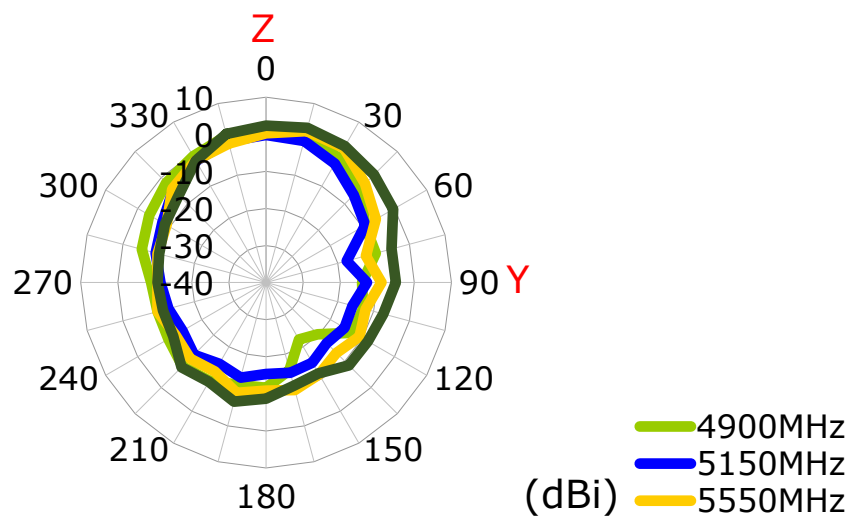
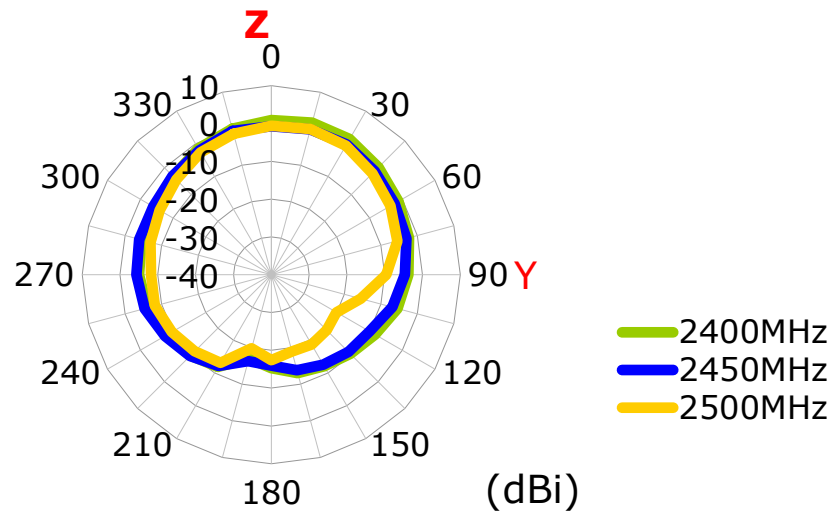

4.2.3 Wi-Fi MIMO 3

XY Plane

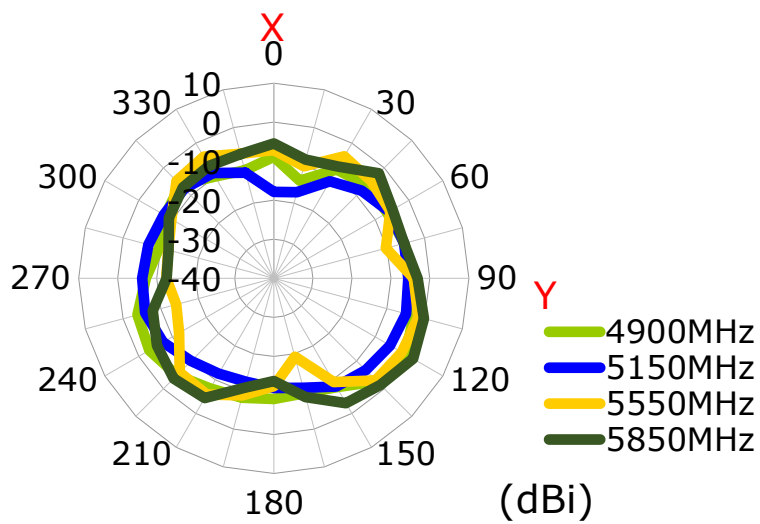
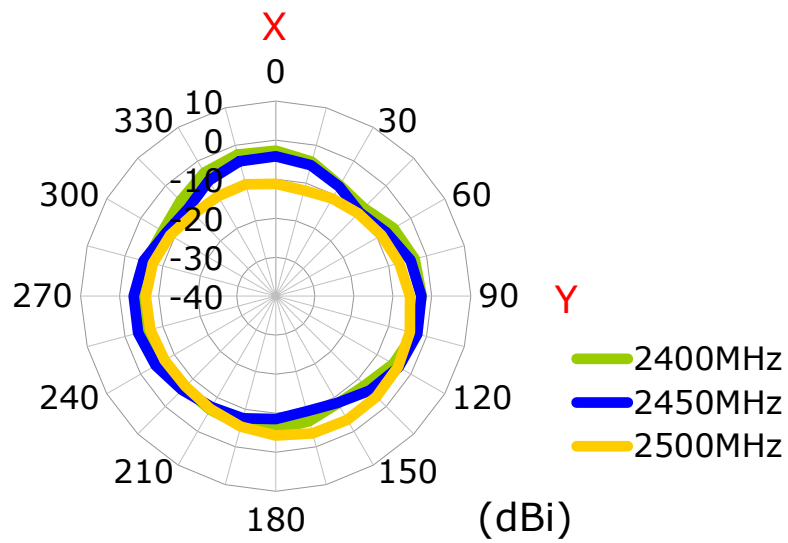

XZ Plane

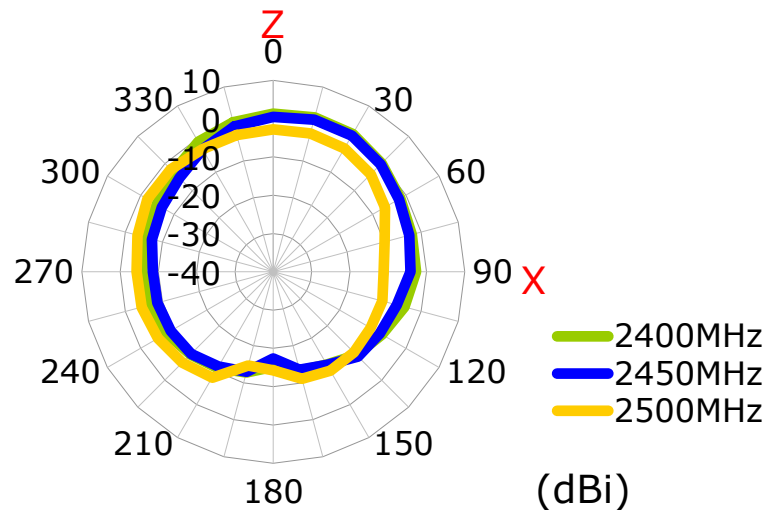

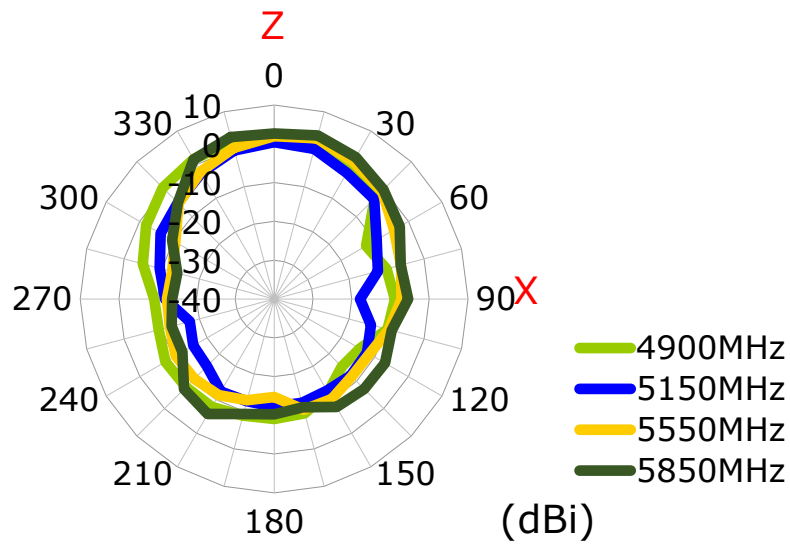

YZ Plane

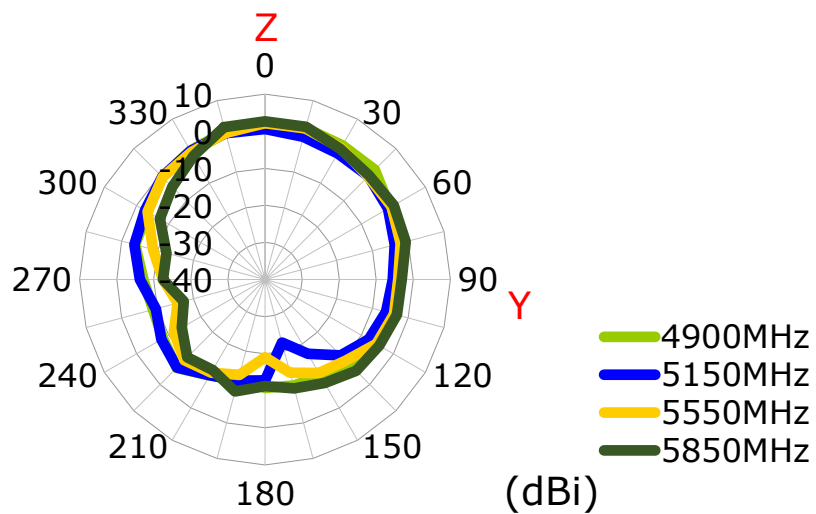
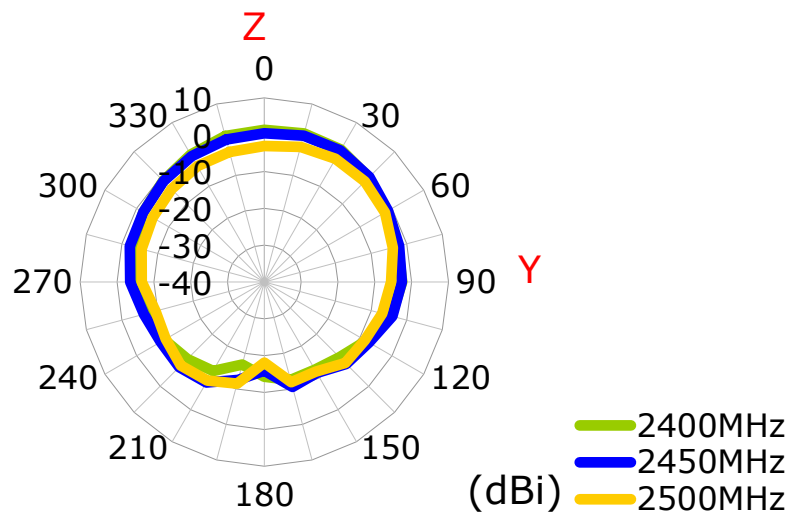

4.3 3D Radiation Patterns

4.3.1 Wi-Fi MIMO 1

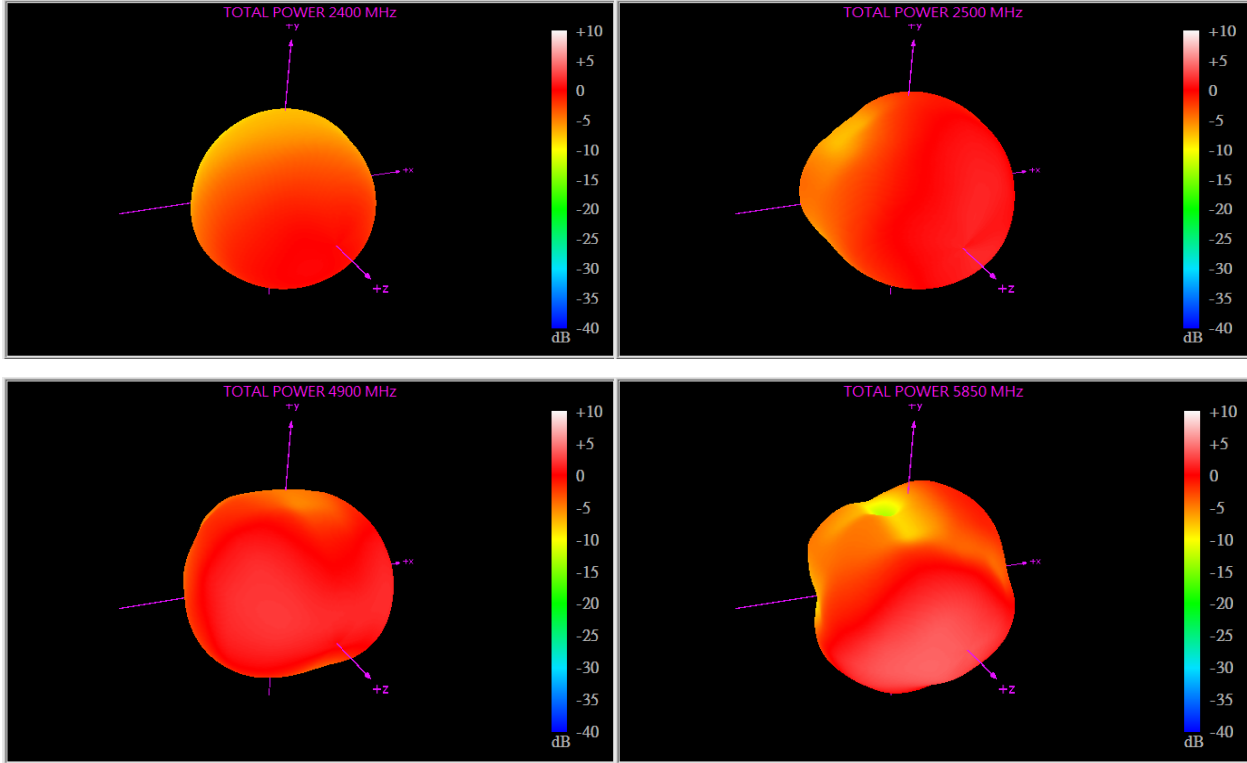

4.3.2 Wi-Fi MIMO 2

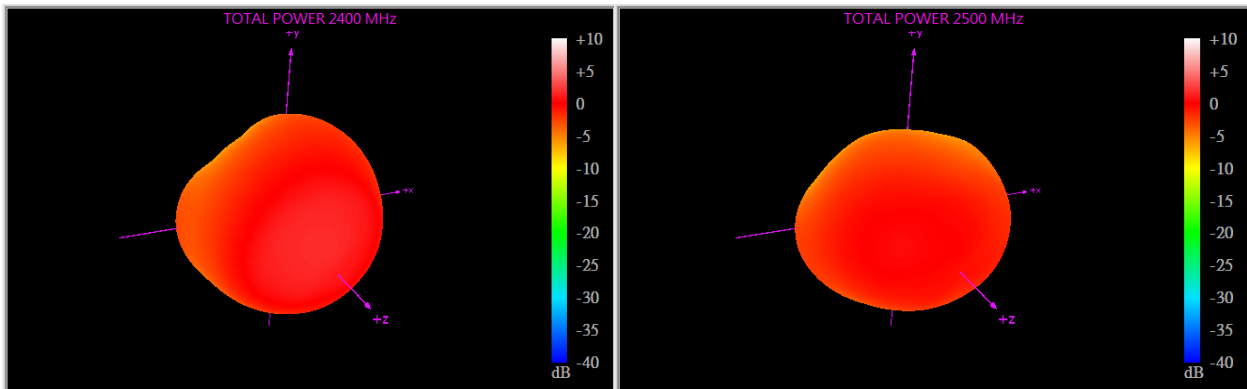

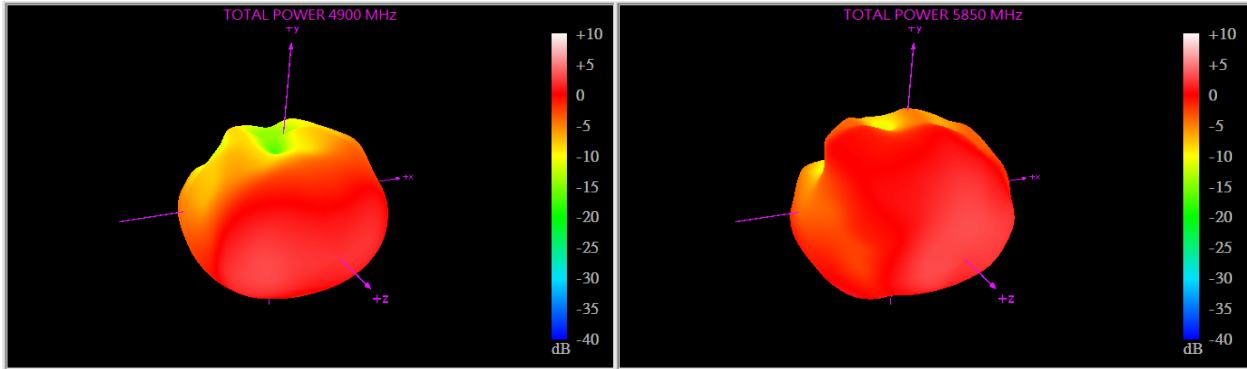

4.3.3 Wi-Fi MIMO 3

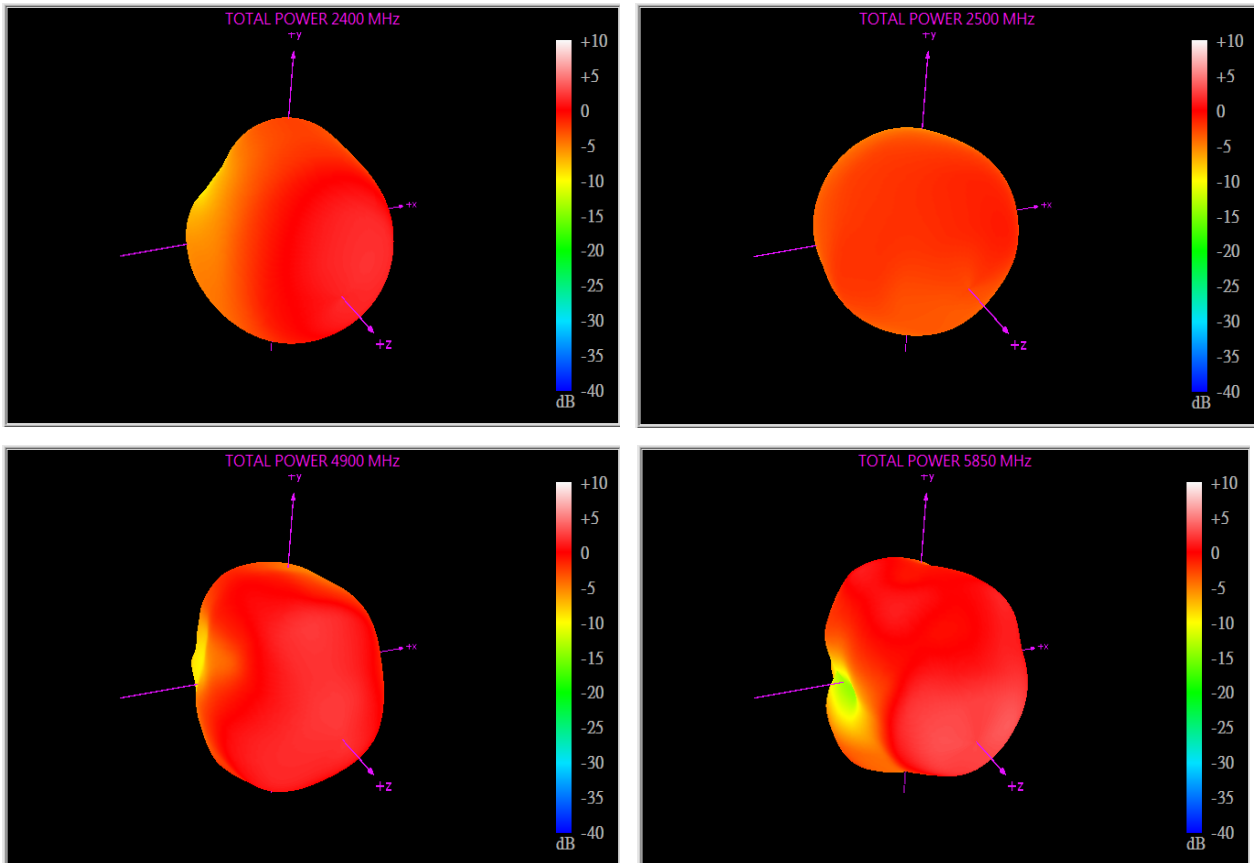

4.4 Axial Ratio

4.4.1 Wi-Fi MIMO 1

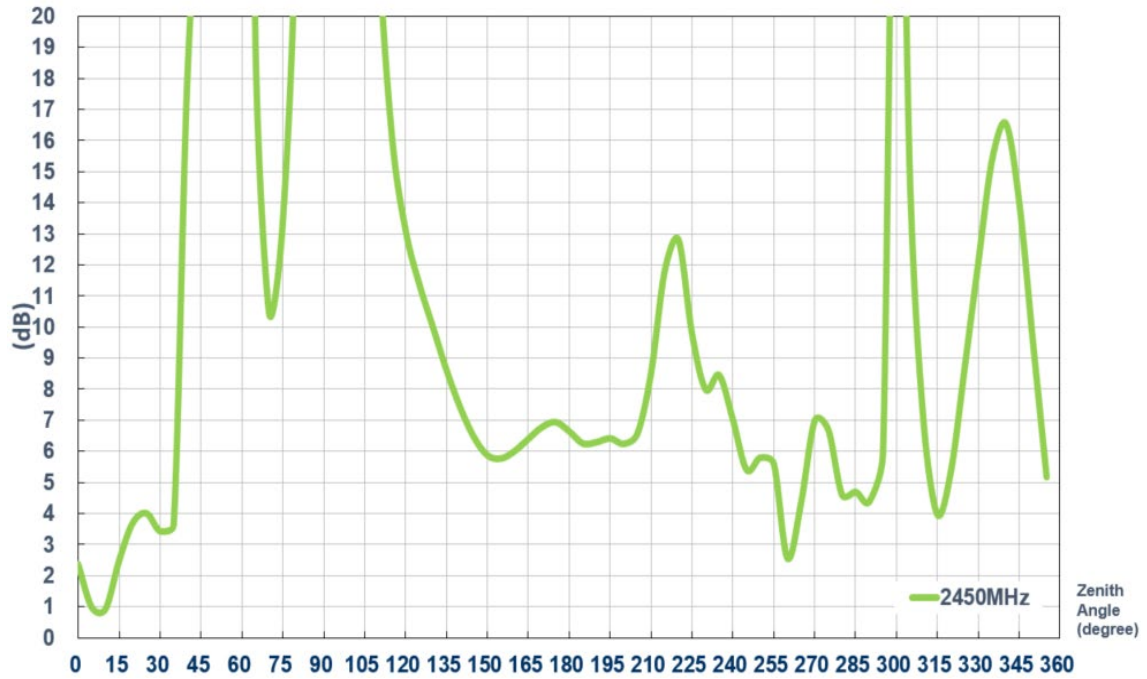

0° is toward Zenith

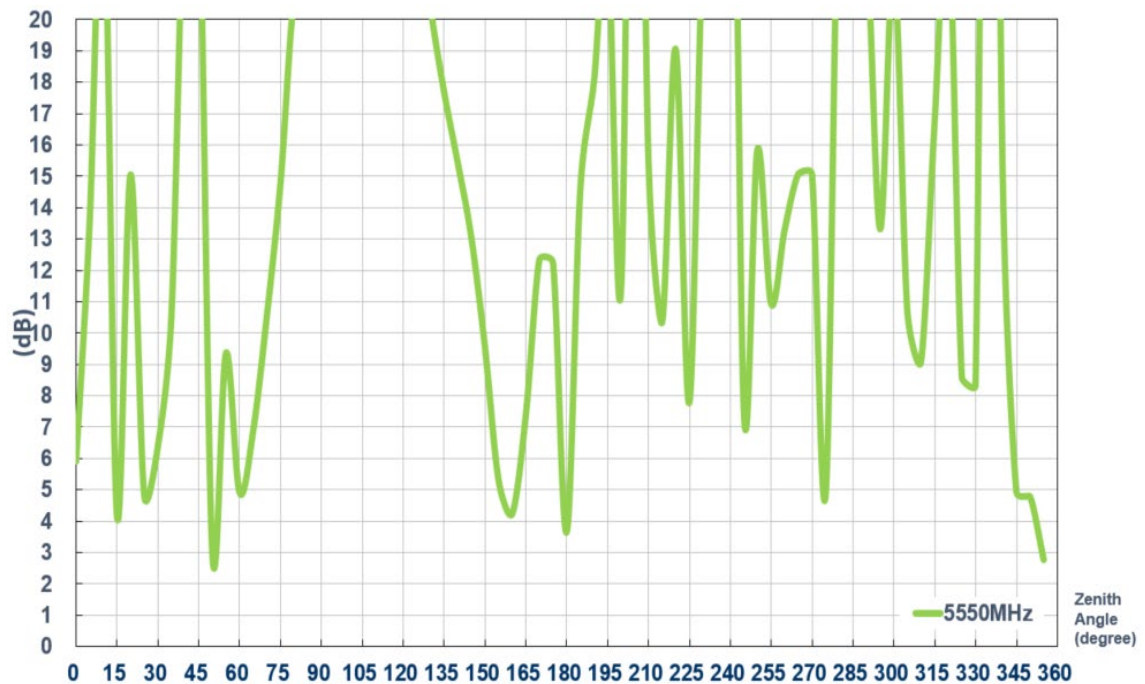

0° is toward Zenith

4.4.2 Wi-Fi MIMO 2

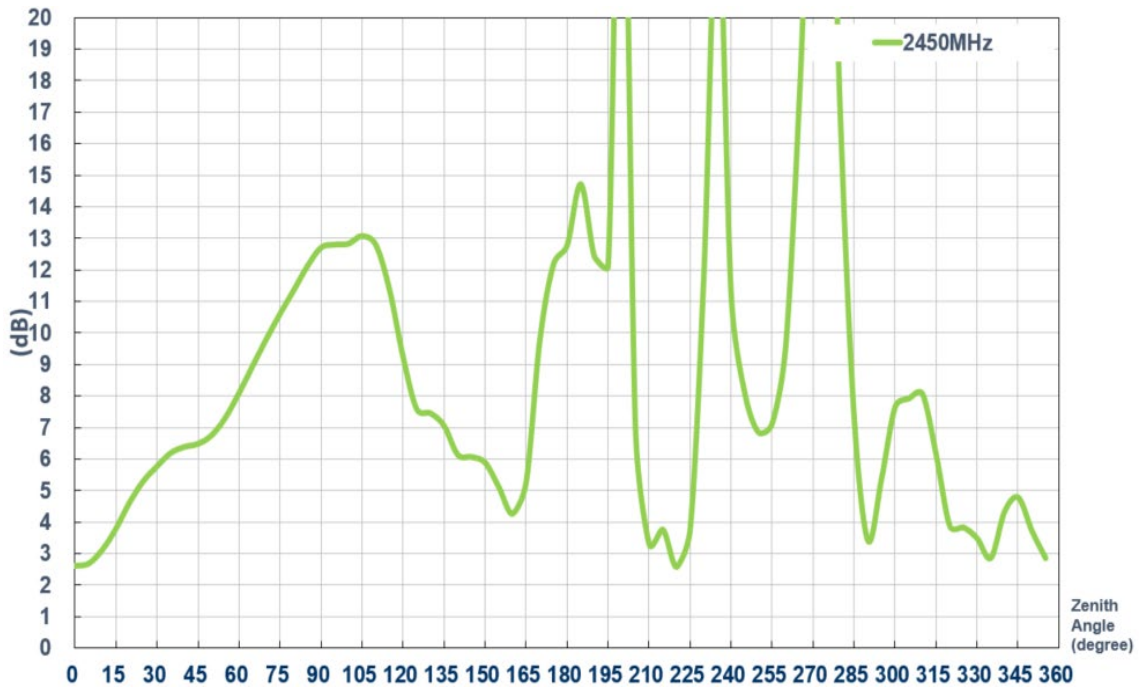

0° is toward Zenith

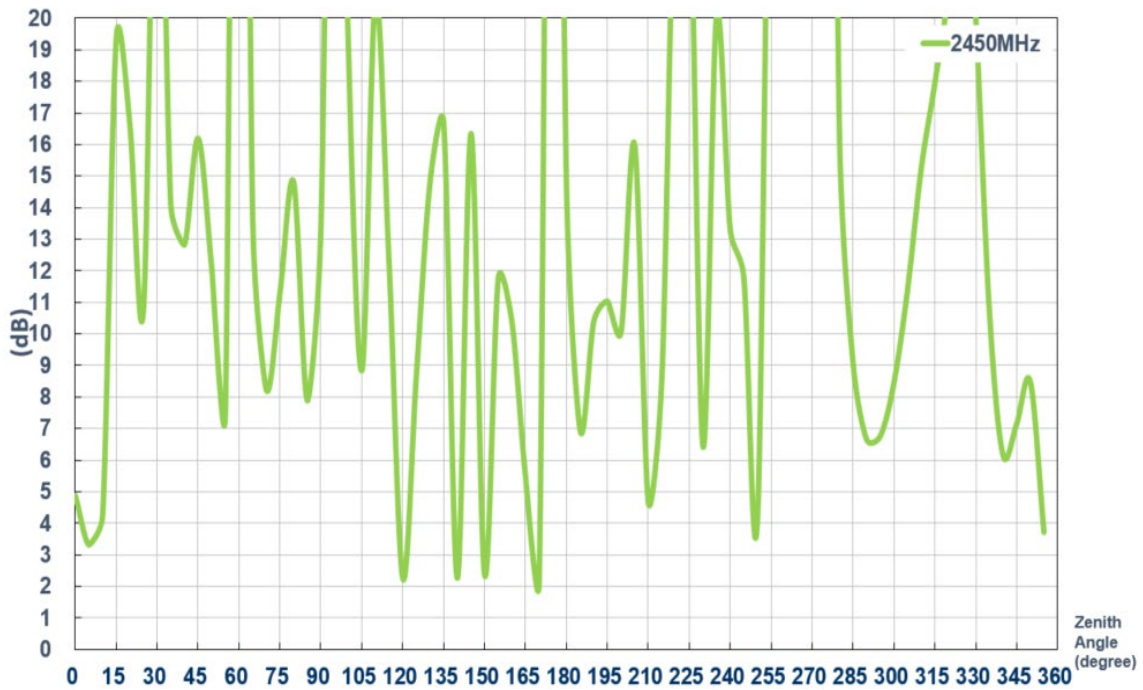

0° is toward Zenith

4.4.3 Wi-Fi MIMO 3

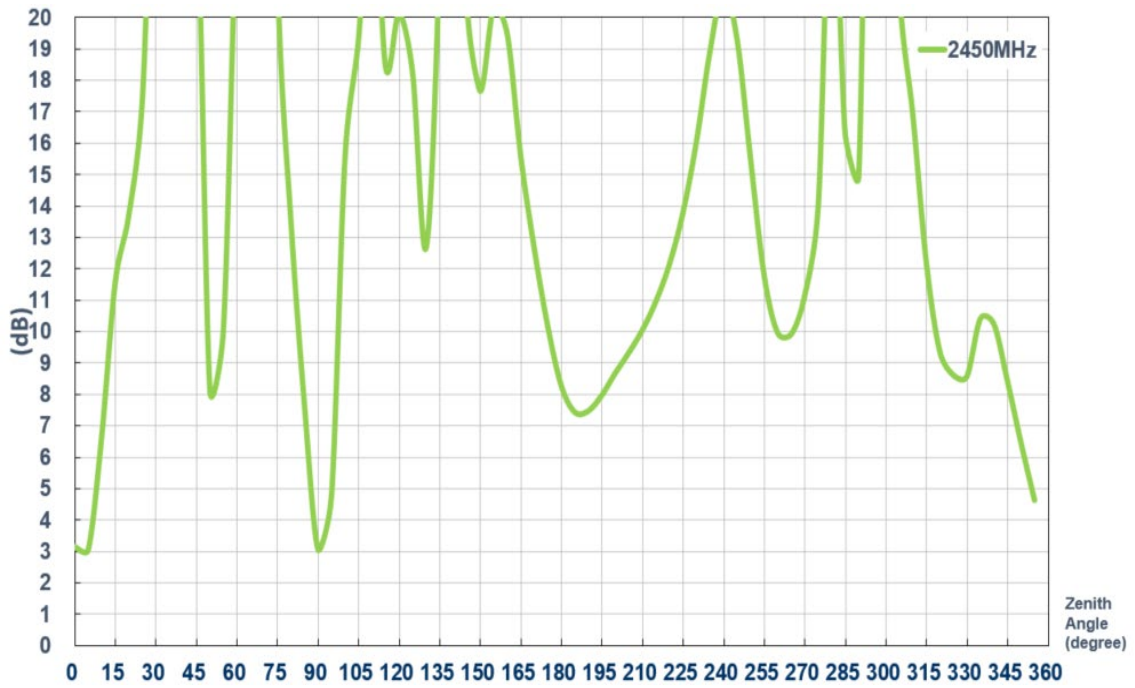

0° is toward Zenith

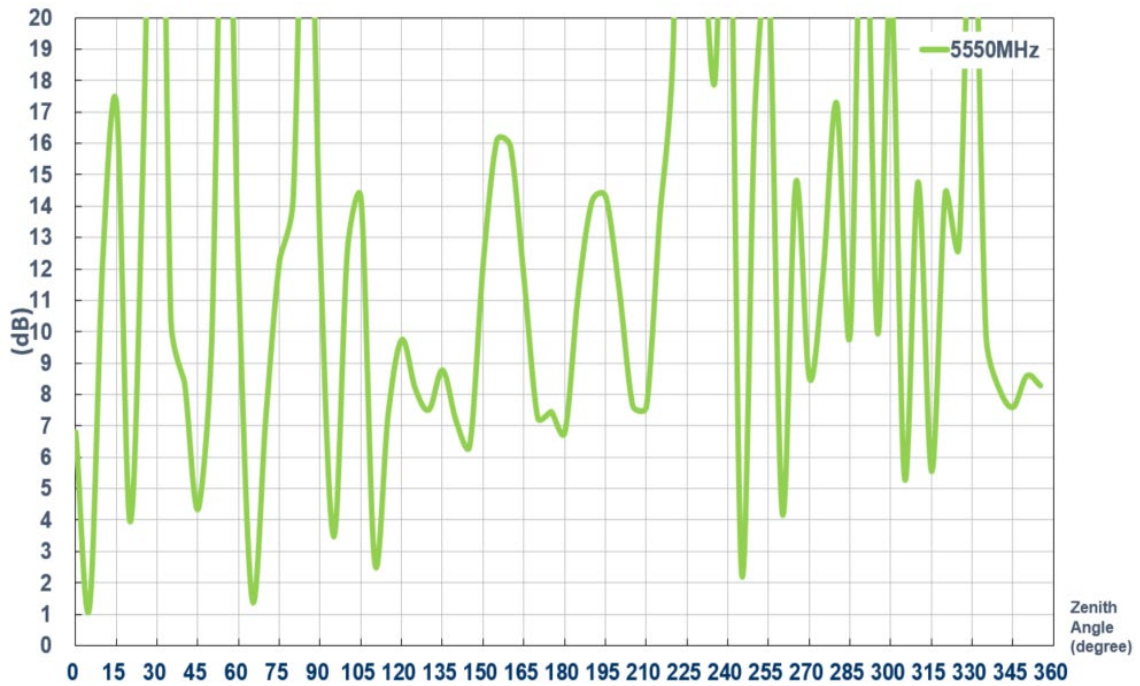

0° is toward Zenith

5. Mechanical Drawing (Unit: mm)

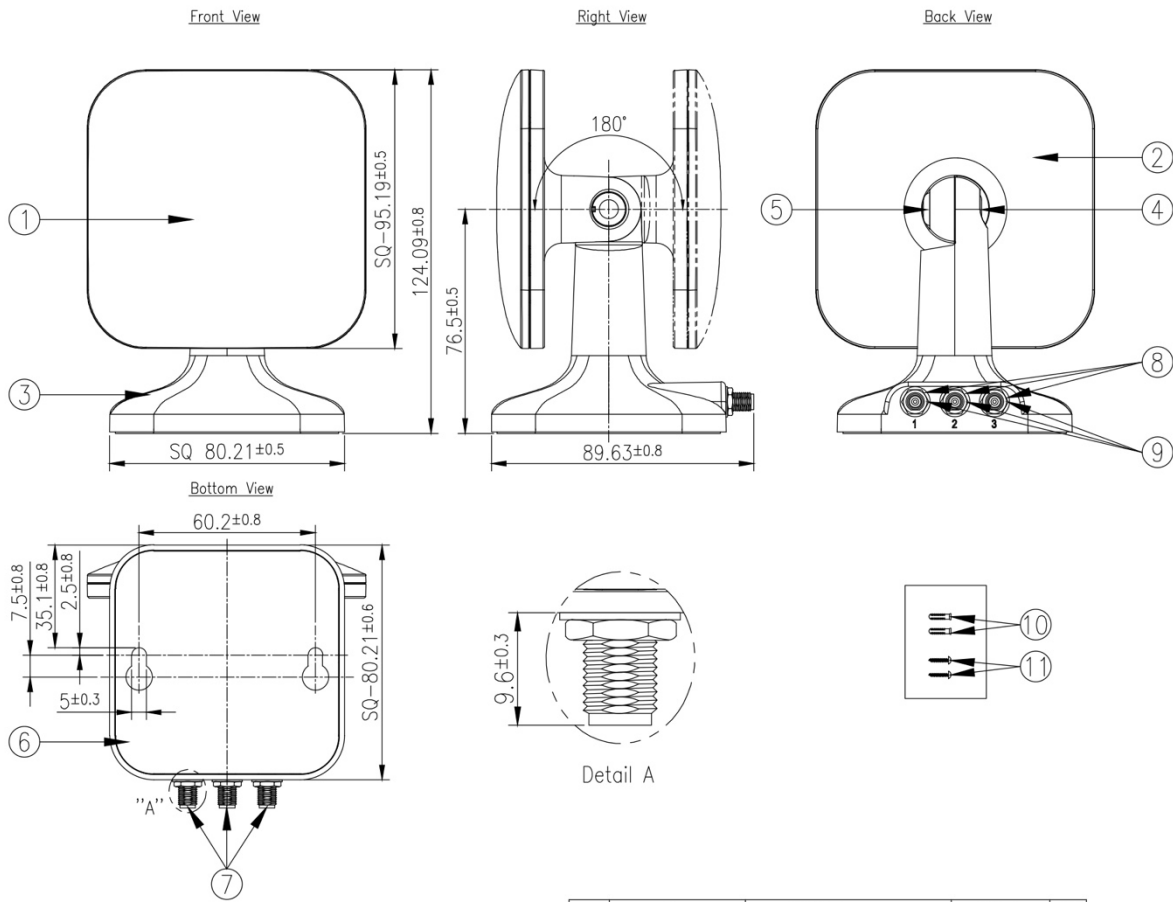

There are 16 position points for rotation in 180 degrees

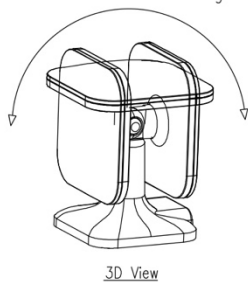

	Name	Material	Finish	QTY
1	Housing Top	ASA	White	1
2	Housing Bottom	ASA	White	1
3	Shaft_3 Holes	PC	White	1
4	HOOK-1	PC	White	1
5	HOOK-2	PC	White	1
6	Foam	HH48C 1.2t+3M 9448+Mylar	Black	1
7	SMA(F)BK ST	Brass	Au Plated	3
8	Washer	Brass	Au Plated	3
9	Nut	Brass	Au Plated	3
10	Screw Holder	Nylon	White	2
11	Screw 4*25L	Steel	Ni Plated	2

6. Packaging

1 pc WMA.328.A.001 per box
Dimensions - 385*120*120mm
Weight - 743g

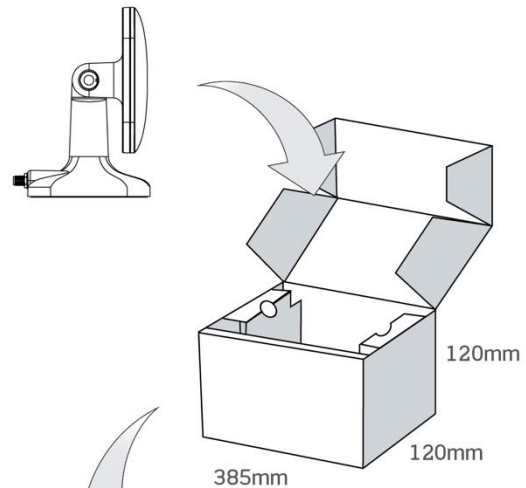

12 pcs WMA.328.A.001 per carton
Carton Dimensions - 405*500*380mm
Weight - 10.12Kg

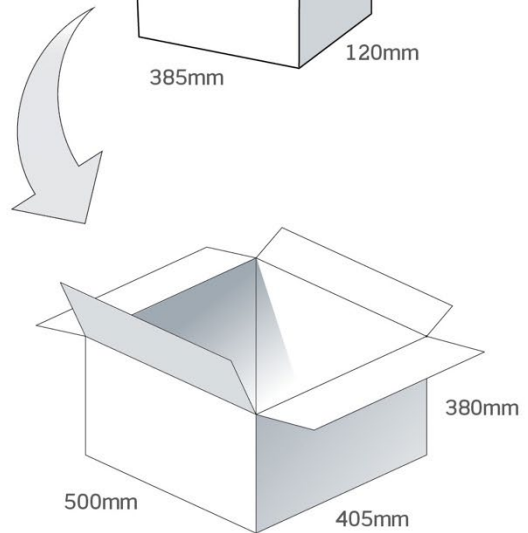

7. Application Note

Antenna performance versus cable length is shown below

7.1 Return Loss

7.1.1 Wi-Fi MIMO 1

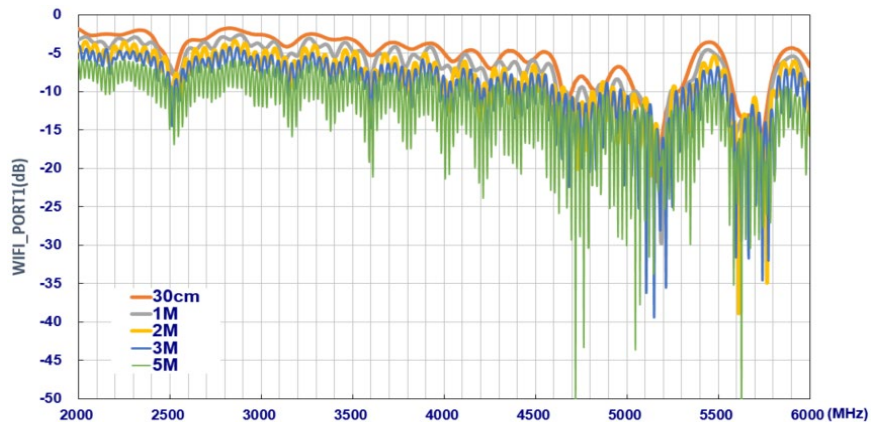

7.1.2 Wi-Fi MIMO 2

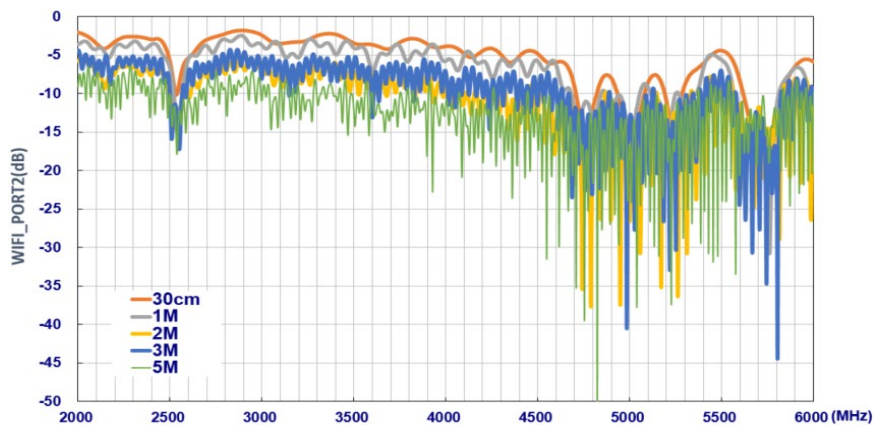

7.1.3 Wi-Fi MIMO 3

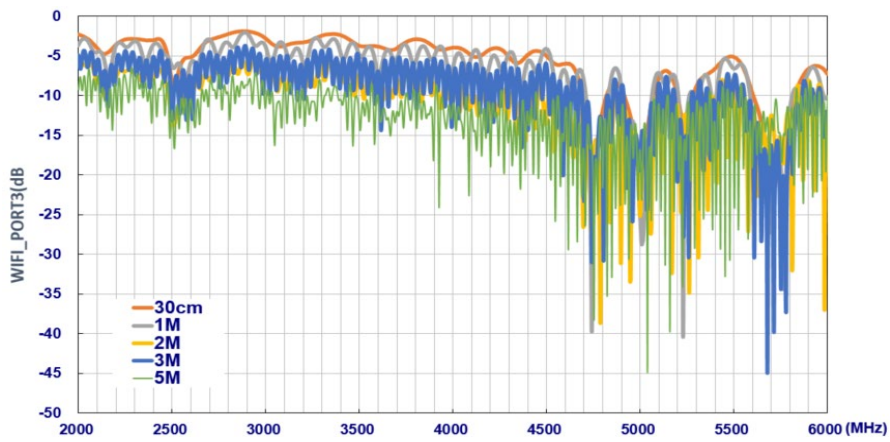

7.2 Efficiency

7.2.1 Wi-Fi MIMO 1

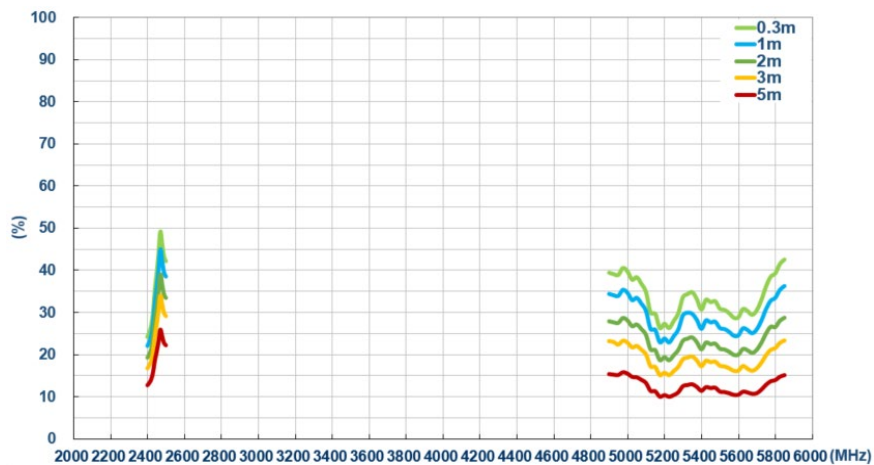

7.2.2 Wi-Fi MIMO 2

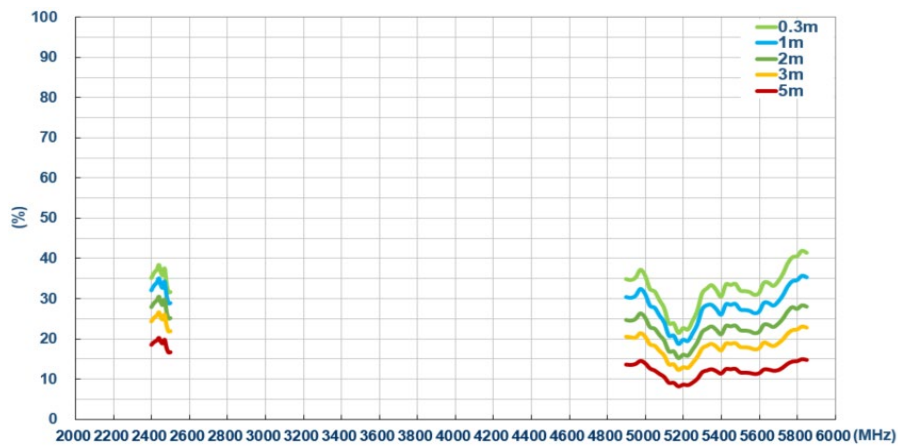

7.2.3 Wi-Fi MIMO 3

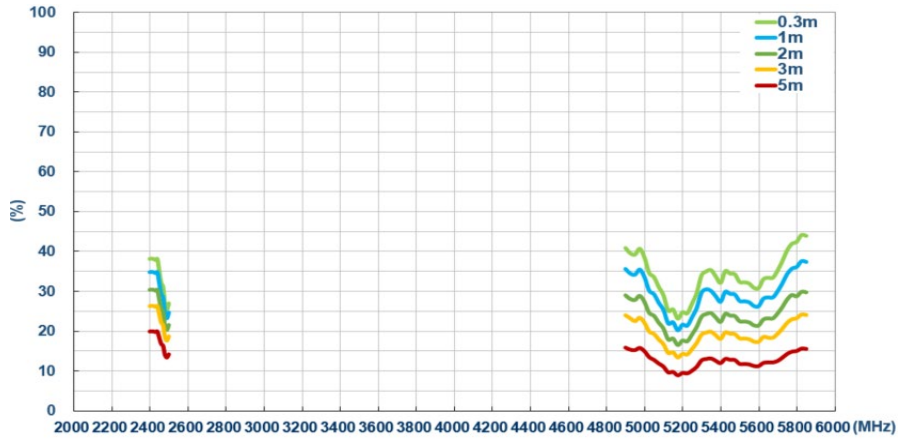

7.3 Average Gain

7.3.1 Wi-Fi MIMO 1

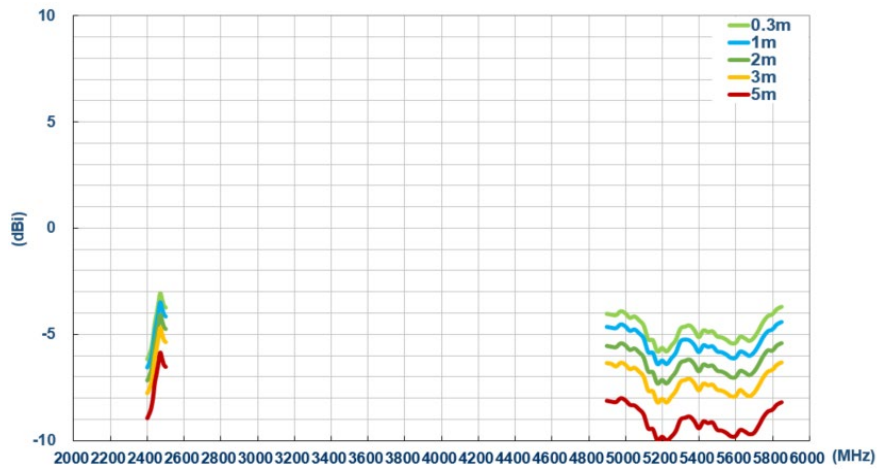

7.3.2 Wi-Fi MIMO 2

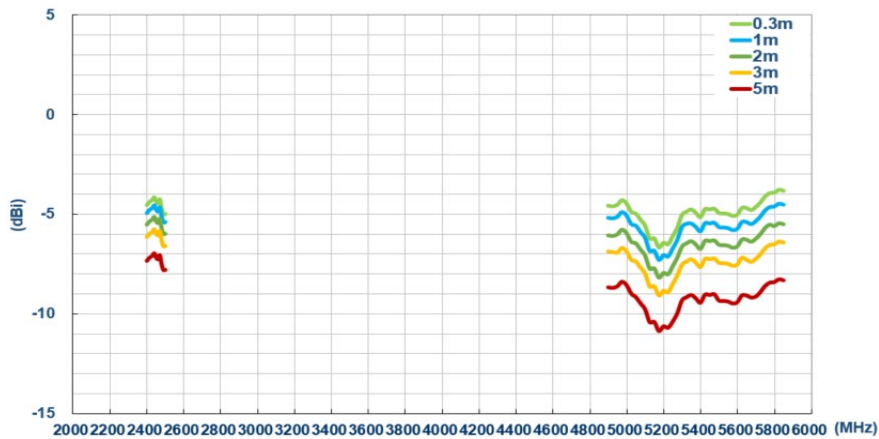

7.3.3 Wi-Fi MIMO 3

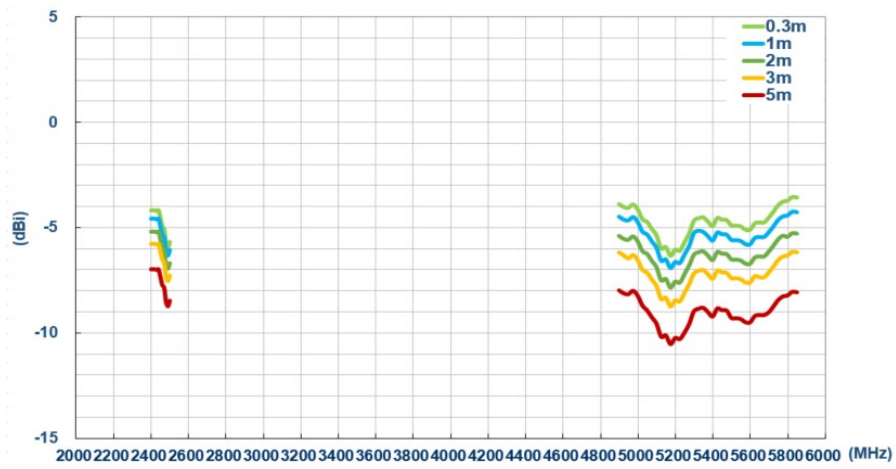

7.4 Peak Gain

7.4.1 Wi-Fi MIMO 1

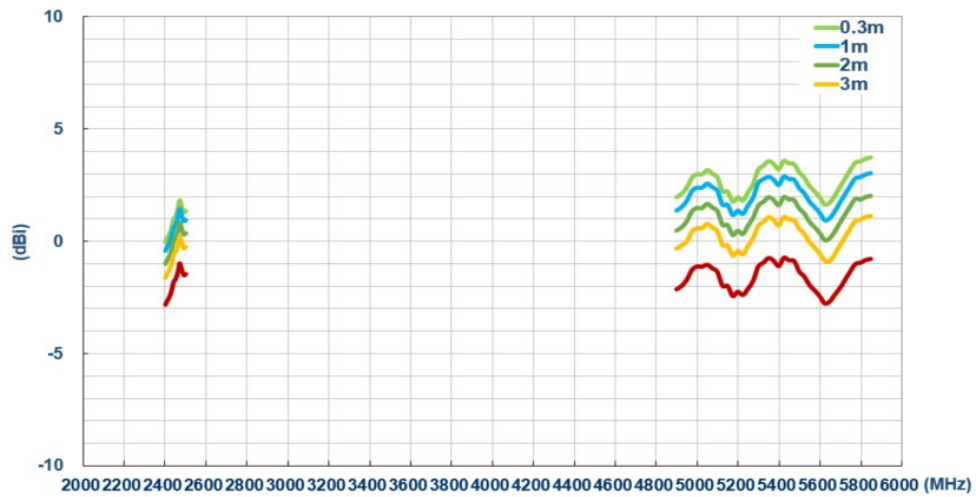

7.4.2 Wi-Fi MIMO 2

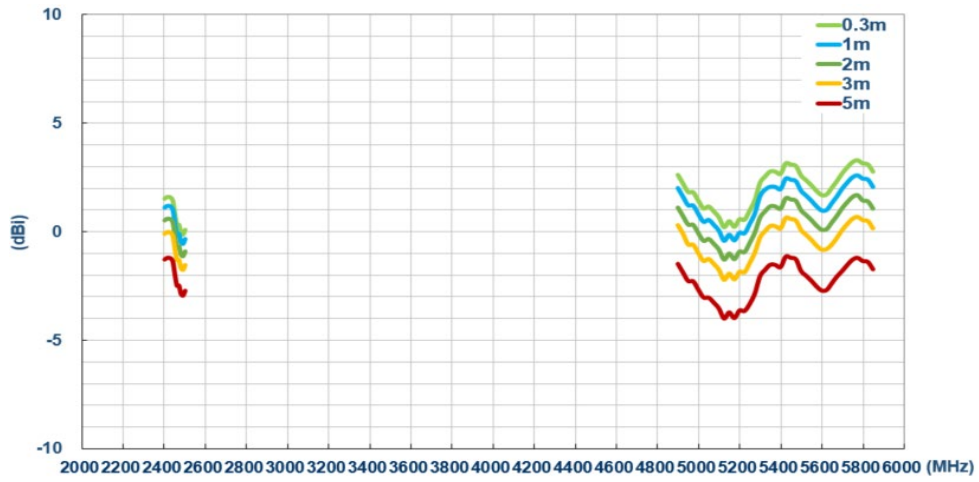

7.4.3 Wi-Fi MIMO 3

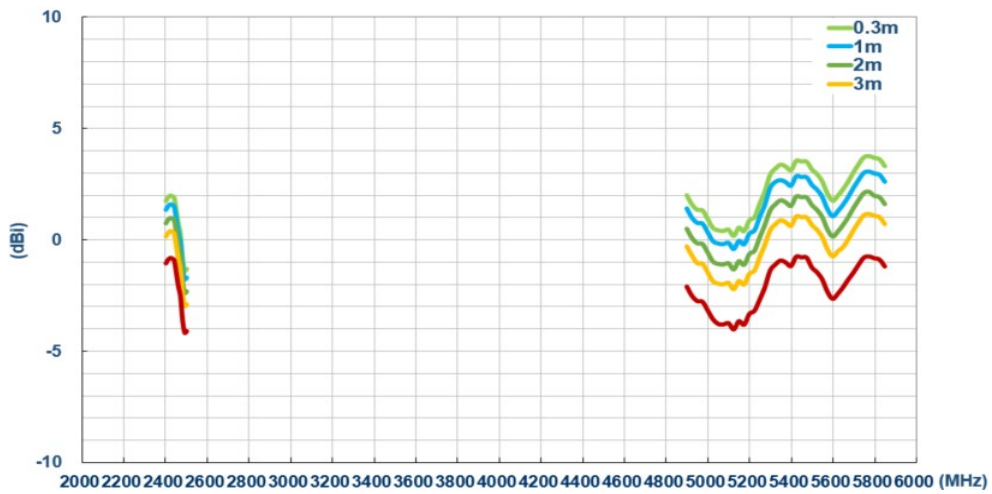

Taoglas makes no warranties based on the accuracy or completeness of the contents of this document and reserves the right to make changes to specifications and product descriptions at any time without notice. Taoglas reserves all rights to this document and the information contained herein.

Reproduction, use or disclosure to third parties without express permission is strictly prohibited.

Copyright © Taoglas Ltd.

