

STS.01

**Spartan Iridium Transceiver
Antenna System**

User Manual



Contents

- 1. Introduction 3
- 2. Installation 3
- 3. Cable 5
- 4. Powering the Device..... 6
- 5. Enabling the Iridium Radio 6
- 6. Serial Communication..... 6
- 7. Network Available Output 6
- 8. Tamper Detection..... 7
- 9. Device Performance 8
- 10. Mechanical Drawing..... 14

1. Introduction

This document covers details and usage of the Spartan STS.01 product. The document includes installation and functional instructions for the user.

2. Installation

The device needs to be installed so that it has a clear view of the sky. The flat, metal base plate should be facing downward, and the domed plastic top is required to be pointed straight up at the sky. Iridium is a satellite system so the unit needs to be able to see the satellites in order to communicate with the Iridium system.

The provided washer and nut can be used to mount the device through a hole in a flat surface, as shown below in Figure 1. The bottom of the device has an adhesive foam pad that keeps the unit from rotating in place. This also seals the hole from water ingress. Be sure to remove the paper backing prior to seating the unit in its mounting hole.

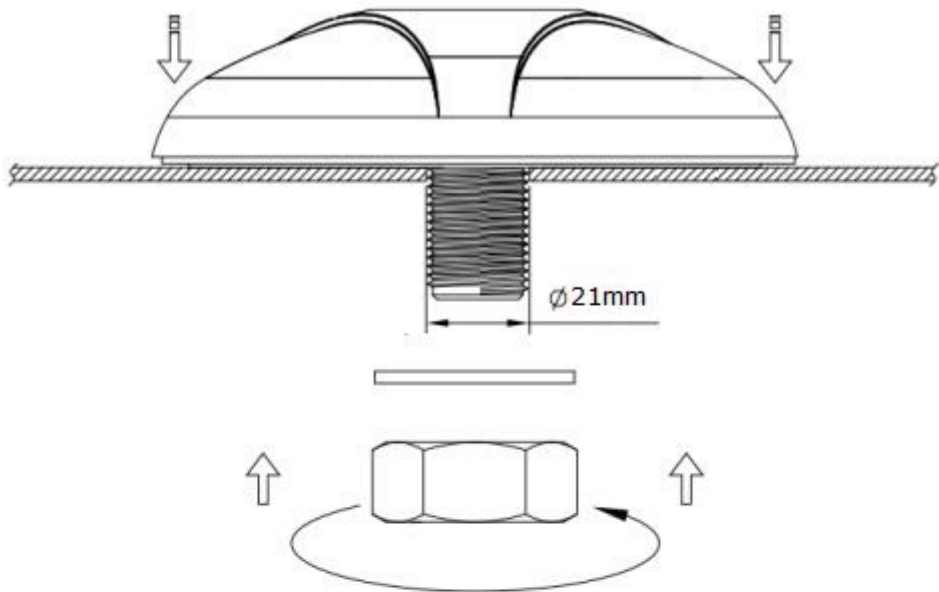

Recommended Torque for Mounting 29.4 N·m
 Maximum Torque for Mounting 39.2N·m

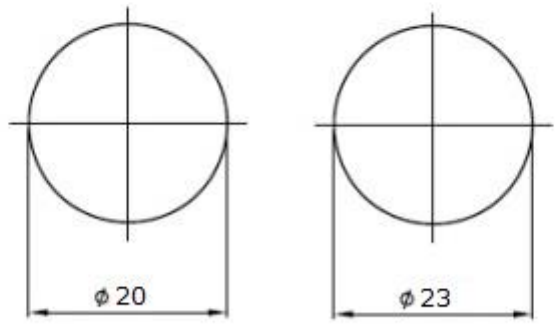

**Thread
 Diameter**

**Recommended
 Mounting Hole**

Unit: mm

Figure 1 - Proper Device Orientation

3. Cable

The STS.01 has a single 8-conductor cable for power and communication. The conductor description is as follows:

Conductor Color	Conductor Function
Red	Power Input (+8-32V)
Black	Power and Signal GND
Orange	On/Off Control (>1.4v Input to enable Iridium module)
Blue	Network Available (+3.3V Output)
Green	RX (Relative to Antenna Module)
Yellow	TX (Relative to Antenna Module)
Gray	Tamper Detect
White	Chassis Ground
Drain Wire	Internally connected to Chassis Ground

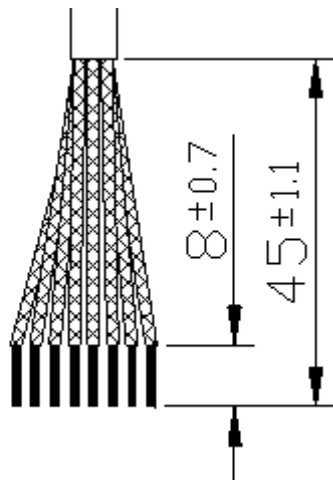

Figure 2 – Cable Diagram

4. Powering the Device

The power input (red conductor) can be supplied with +8 to +32V. The black conductor is the signal and power ground for the device. The power/signal ground must be connected to the same GND as the power source. This same connection is also the ground reference for the serial interface and must be broken out (split) for both power input and signal ground functions.

Chassis ground (white conductor and drain wire) can be tied to power/signal ground or can remain isolated. Chassis ground is not electrically connected to anything inside the product, other than the metal base plate and the tamper detection line.

5. Enabling the Iridium Radio

Once the device is powered it is in idle state. There will be no radio communication until the user enables the Iridium module. A voltage of at least 1.4V must be applied to the orange conductor to enable the radio. This line may be connected to the power input of the device if desired.

6. Serial Communication

Once the device is powered and the radio is enabled, communication with the radio module can occur via RS232C signaling levels. The default baud rate of the device is 19200-N-8-1. The green conductor is the device RX (input) and the yellow conductor is the device TX (output). The Iridium AT command set must be used for configuration and communication.

7. Network Available Output

The Network Available digital output (blue conductor) can be monitored to verify network availability. This output will be +3.3V when the radio can see a satellite and 0V when no network is available. This signal is current limited with an internal 10k resistor.

8. Tamper Detection

The tamper detection conductor can be used to determine if the cable has been accidentally or intentionally cut by implementing a 10k ohm pullup resistor on the user's OEM device that the STS.01 connects to, as shown below in Figure 3.

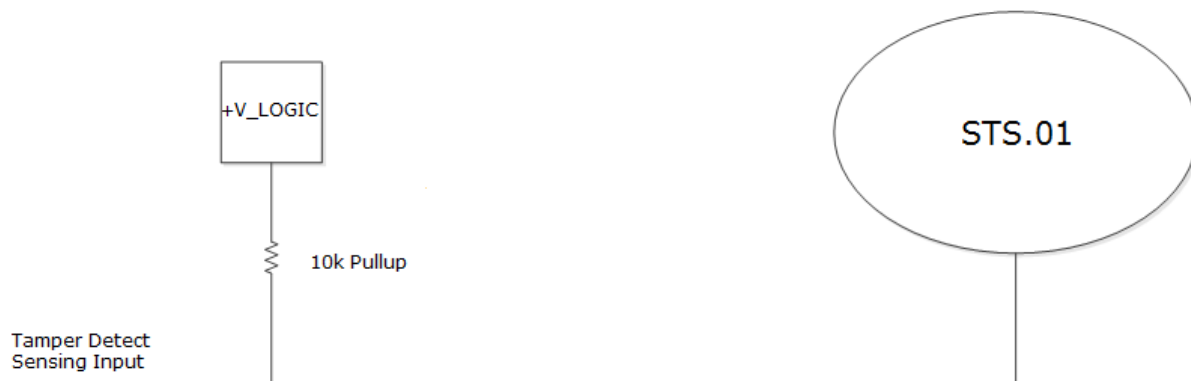

Figure 3 - Tamper Detection Pullup

Vlogic is the logic high supply voltage of the sensing input device. While the device's cable is intact, the tamper detection line will be 0V. When the cable is cut, Vlogic will be present on the tamper detection line.

The tamper detection line is connected to the Chassis Ground line of the cable and thus to the base of the device. This signaling scheme assumes the Chassis Ground line is connected to the same reference ground as the ground reference of the sensing device.

Using the tamper detection line is optional. The device is fully functional if the user decides not to use the tamper detection line. If unused tamper detect should be left floating or tied to the same point as Chassis Ground.

9. Device Performance

9.1 Iridium Approval

The Spartan STS.01 has been approved by Iridium for use on the Iridium satellite system. The approval process involves a side-by-side comparison to Iridium's baseline antenna. The baseline antenna is similar in size to the Spartan STS.01. Therefore, the baseline antenna should be viewed as maximum potential performance for any device. There are 4 performance characteristics that are covered in this comparison. Those characteristics are Voice Mode Call Performance, Data Mode Performance, Downlink Margin, and Power Control Efficiency. The testing results are shown in the following sections.

9.1.1 Voice Mode Call Performance

The test consisted of 180 second calls being made to the gateway used in testing. Figure 4 contains the performance results for the antenna for the test duration.

180 Second I2P Voice Calls	Call Attempts	Call Setup Rate	Call Drop Rate	Average Channel Assignment Time	Access Rate	Average Access Time	Average Setup time
Spartan STS.01 Transceiver Antenna System	1220	98.03%	2.93%	4.97	98.20%	7.17	9.85
Iridium Transceiver + Baseline Antenna	1220	98.77%	1.99%	4.76	99.02%	6.93	9.6

Figure 4 - Voice Mode Call Performance

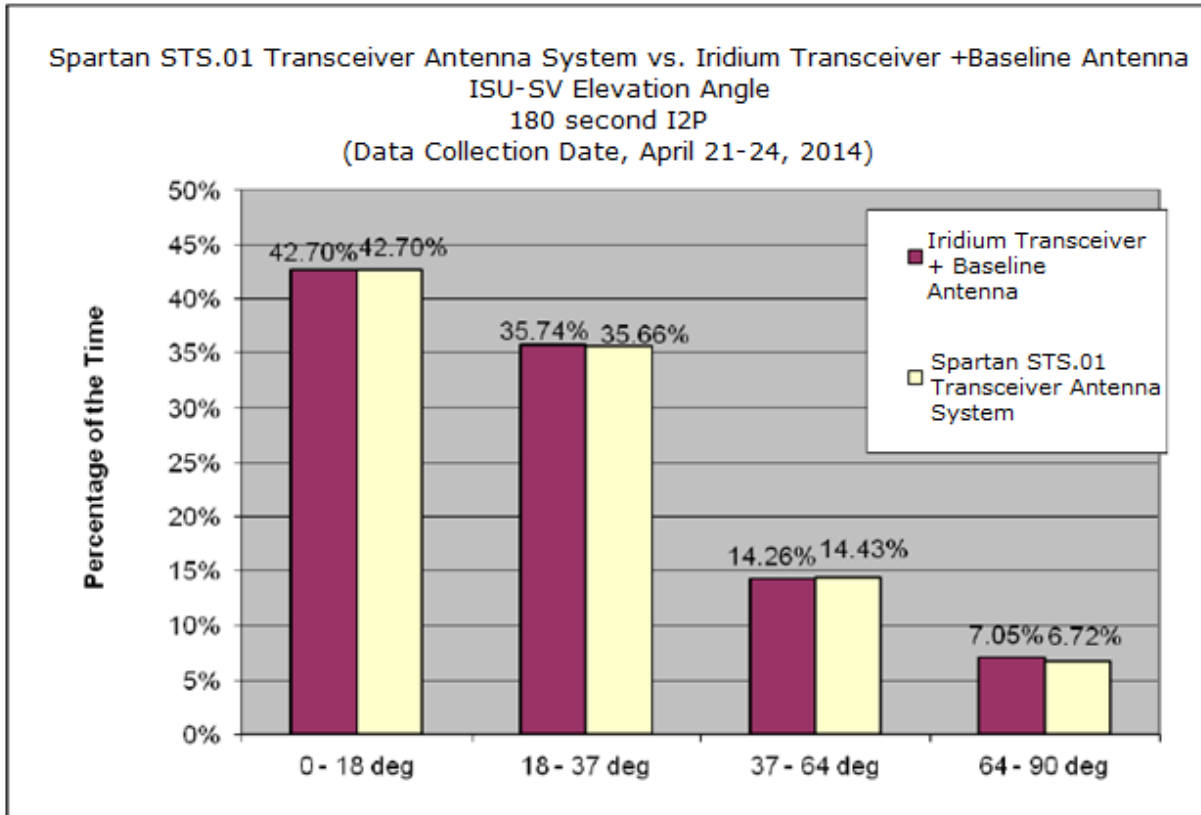

Figure 5 - Voice Mode Call Performance

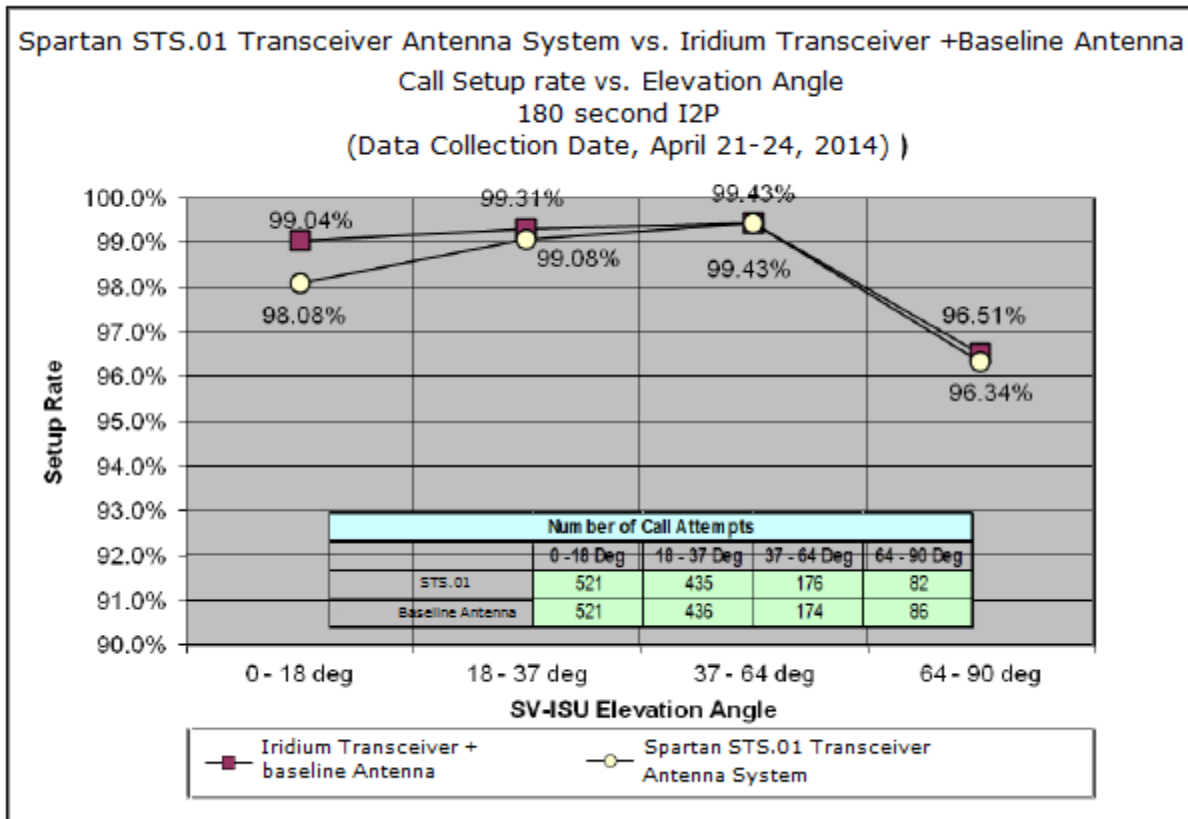

Figure 6 - Call Setup Rate vs. Elevation Angle

9.1.2 Data Mode Performance

Data was collected for one day from data calls performing 50k FTP upload transfers.

FTP 50K Upload	Call Attempts	Call Connect Count	Successful Call Connect Rate	Successful Transfer Count	Successful Transfer Rate	Average Throughput (Kb/sec)
Spartan STS.01 Transceiver Antenna System	942	891	94.59%	856	90.87%	2.62
Iridium Transceiver + Baseline Antenna	946	909	96.09%	891	94.19%	2.66

Figure 7 - Data Mode Performance

9.1.3 Downlink Margin Performance

The figures below depict the link margin on a per beam basis, evaluating only the traffic channel and does not include values that are 0 dB or less.

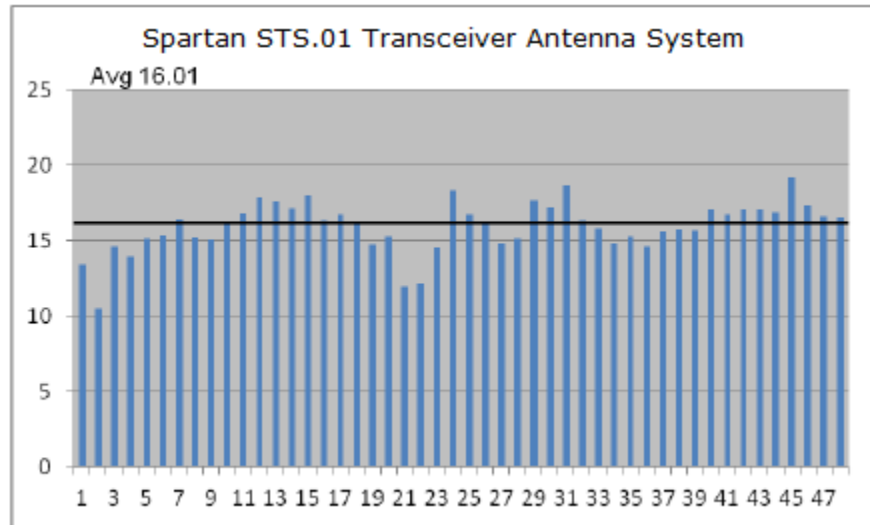

Figure 8 – Spartan STS.01 Transceiver Antenna System Link Margin per Beam

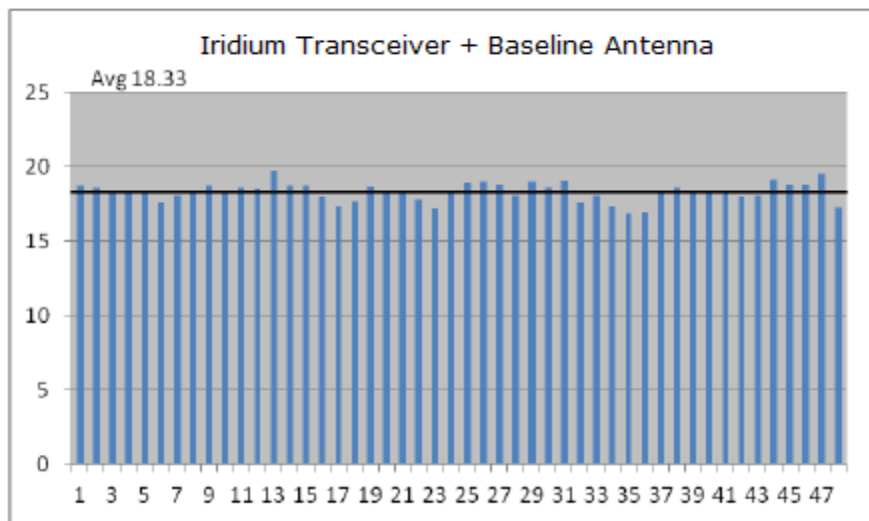

Figure 9 – Iridium Transceiver + Baseline Antenna Link Margin per Beam

9.1.4 Power Control Efficiency

The results are presented in terms of Capacity Factor, which is a ratio of voice call power to full power. Capacity Factor is calculated by determining the amount of time spent at various power levels during uplink and downlink.

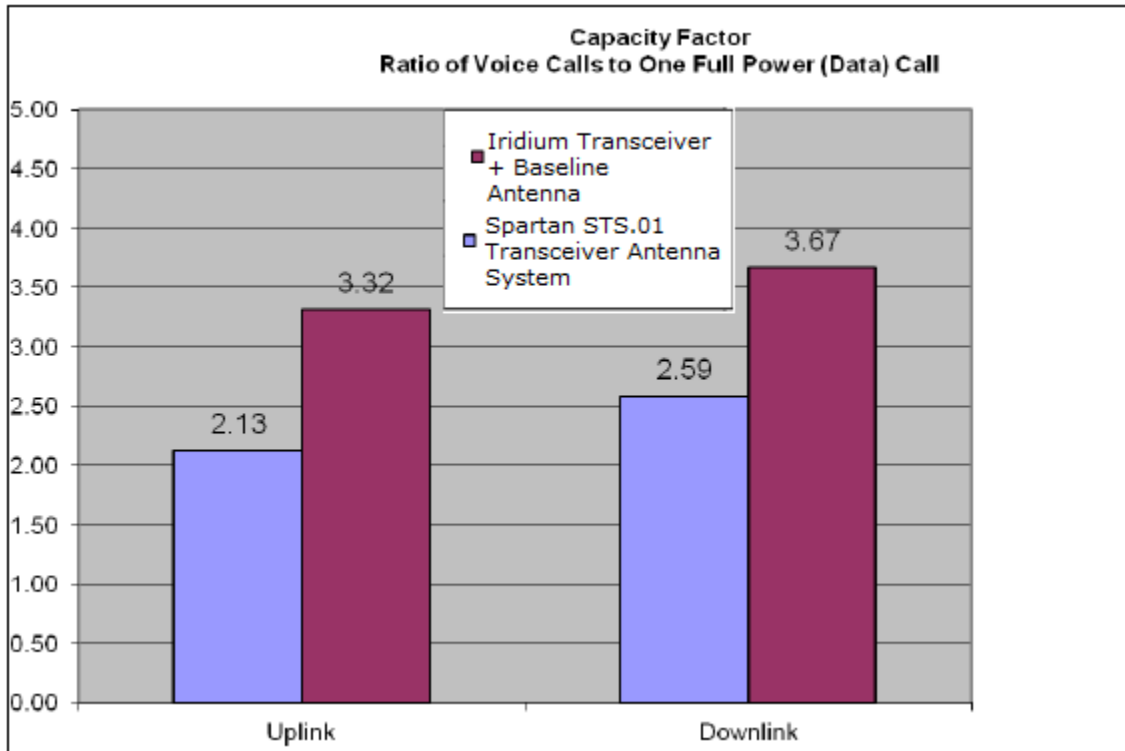

Figure 10 - Capacity Factor

9.2 Automotive Electrical Transients

The STS.01 is designed to maintain at least Class C operation for all transients defined in ISO 16750-2, ISO 7637-2, and ISO 7637-3. Class C operation means the device functionality will return to normal after the transient event without user intervention. The STS.01 actually maintains Class A operation for many of the transients including the load dump transient, defined in ISO 16750-2, Section 4.6.4, complying with the most severe 24V system requirements. Class A operation means the device functions as designed without interruption and without user intervention during the transient event. Other similar devices incorporate a user-replaceable fuse to overcome the severe load dump transient. This allows the manufacturer to claim Class D operation, meaning the user has to remove the device from its mounting location, open it up,

and replace the fuse to get the device back to normal operation after a transient event. This is not convenient in many applications, which is why the STS.01 is a superior option.

A short-circuit test is also defined in ISO 16750-2, Section 4.10, where all inputs and outputs must be tied to the power source and then to ground for a duration of 60 seconds each. This verifies there is no damage to the device when the user accidentally connects an I/O line to the wrong terminal. The STS.01 completed all of these tests assuming a 24V system, resulting in a very robust device.

Refer to ISO 16750-2, ISO 7637-2, and ISO 7637-3 for a complete list of specifications. The STS.01 successfully meets all of the requirements defined.

10. Mechanical Drawing

Side View

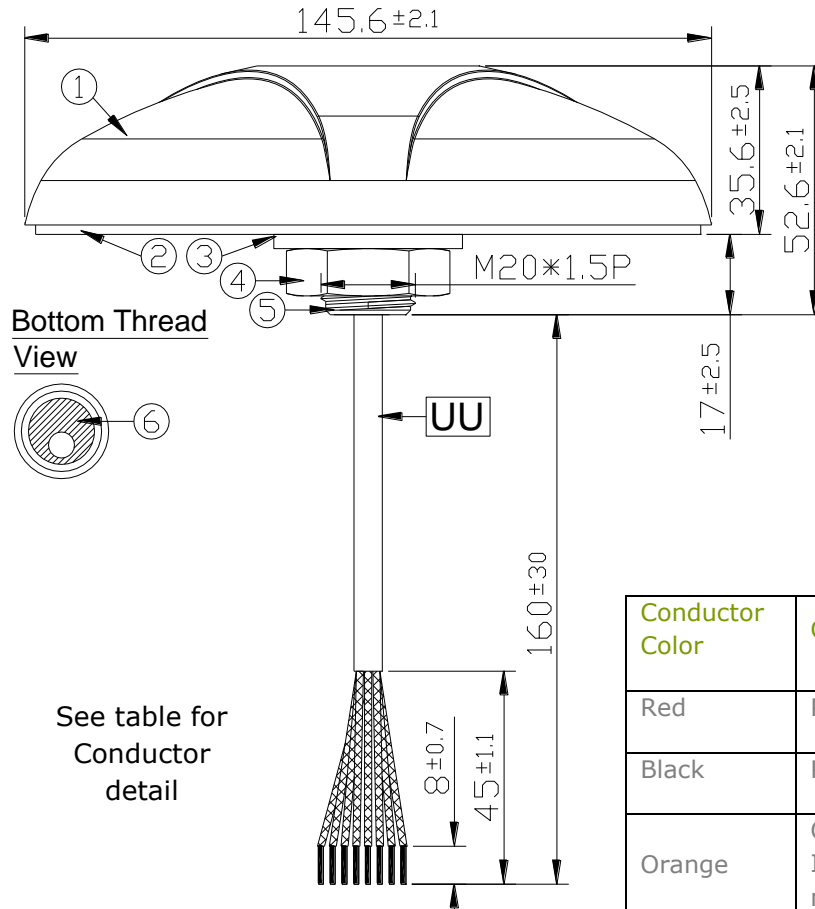

See table for
Conductor
detail

Conductor Color	Conductor Function
Red	Power Input (+8-32V)
Black	Power and Signal GND
Orange	On/Off Control (>1.4v Input to enable Iridium module)
Blue	Network Available (+3.3V Output)
Green	RX (Relative to Antenna Module)
Yellow	TX (Relative to Antenna Module)
Gray	Tamper Detect
White	Chassis Ground
Drain Wire	Internally connected to Chassis Ground

	Name	Material	Finish	QTY
1	Housing Spartan ST	PC + ABS	Black	1
2	Closed Cell Foam	3M 9448+CR-4305	Black	1
3	Nut_M20x1.5Px10H Cut	Steel	Ni Plated	1
4	Washer Nut	Steel	Ni Plated	1
5	Metal Base ST	Zinc Alloy	Ni Plated	1
6	Cable Rubber	Silicone Rubber	Black	1
UU	Cable Type	5118C	Grey	1