

Self-Interference: A Primer

One of the primary factors affecting TIS performance in real devices is Self-Interference, also known as self-quieting or self-jamming.

Self-interference is the phenomena where a receiver's performance is degraded by unrelated emissions at the same or similar frequency to the desired signal. Self-interference, to the receiver, is simply a particular type of noise which degrades the received signal-to-noise ratio (SNR).

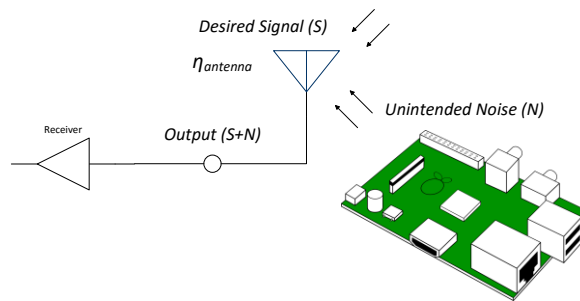

Figure 1: Signal and noise

Self-interference is not new and was first described for FM radios, where the radio would lock onto the wrong signal, internally generated—producing no audio, or quiet. Hence the term “self-quieting” was born.

The problem manifests itself somewhat differently in modern digital radios than in the FM radios of yesteryear. Whereas the “self” in self-quieting for FM radios referred to the radio itself (e.g. local oscillators for downconverters), self-quieting of today is more often associated with electronics not precisely related to the radio itself. Stated another way, today’s self-quieting has everything to do with the signal to noise ratio (SNR). If the noise is too high, the SNR is too low, and receiver performance follows.

The electronics which potentially produce interference include, but are not at all limited to: microcontrollers; memory interfaces; display interfaces; oscillators/clocks; and switching power supplies. Any of these electronics left unchecked can produce unwanted emissions at the received frequency.

In most cases, there is no way to remove or filter these emissions if they fall on the same frequency as the received signal. This means the signals must be stopped from entering the antenna but as the antenna cannot be shielded, this means that the emissions must be controlled at their source. Common mitigation methods include shielding, signal filtering, and PCB layout techniques.

For cellular devices, the conducted receiver sensitivity of the cellular radio is well-characterized. As an engineer integrating a cellular module and an antenna, this then places the burden of achieving satisfactory TIS on the antenna efficiency and controlling emissions from the system within the cellular frequency bands.