

# Aerospace & Defense

**WEBINAR: Multi-band GNSS Antenna Integration  
within EMEA Aerospace and Defense**



# Today's Speakers



**Kevin Blakeley**  
Head of Aerospace and Defense - Marine  
Corp Veteran



**Olivier Robin**  
Chief Operations Officer



**Sam McCarthy**  
VP EMEA Sales



# Aerospace & Defense

## WEBINAR: Multi-band GNSS Antenna Integration within EMEA Aerospace and Defense



## Housekeeping

### Have questions?

There's time set aside for Q&A at the end, so please utilize the private Q&A function within the chat box.

### Want to view this webinar again?

Webinar is being recorded, and we will share an on-demand link via email when the webinar ends.

Why Taoglas?



# Industry-leading Antenna Supplier for **A&D Applications**

## **Long History with Aerospace & Defense**

---

Shipped 100,000's of devices to A&D  
and government agencies

Military Veteran Team

## **Experience Handling Tough Requirements**

---

Highly reliable, robust antennas for  
use in harsh environments

Cybersecurity and quality standards  
compliance and certifications

## **In-house Engineering & Manufacturing**

---

Full capabilities globally for security  
and compliance

100+ Engineering experts in the field  
of RF



# Quality & Certifications



## **ITAR Registered with DDTC**

*Directorate of Defense Trade Controls (DDTC)*



## **IPC-A-610 and IPC-A-620S**

*Certified technicians for IPC-A-610 and IPC-A-620S for Military and Space cable assembly applications in our San Diego facility*



## **Customs Trade Partnership Against Terrorism (CTPAT)**

*Approved in May 2025*



## **Cybersecurity Maturity Model Certification (CMMC) – Level 2 Ready**

*ISO 27001 certified*



# Global Engineering Resources & Capabilities



## State-of-the-art RF Test Chambers & Analyzers

- 25+ VNAs WW
- 10 anechoic chambers WW
  - x4 in US from 400MHz to 40GHz
  - Active & Passive Tests
  - Call boxes
- Active Roof Top GNSS test setups in EMEA & Asia
- Customized Production Test Setup



## Engineering Test & Development Labs

- Designed for Manufacturing
- Electronics Design: Gerber, Circuitry
- Software Design: Python
- Mechanical Design: Solidworks
- RF Simulations CST & HFSS
- 3D Printing
- Concept Hardware Prototyping
- Validating & Testing
- Online Catalog of Test & Services for customer project completion by phases



## Environmental Testing & Statistical Analysis

- Validating and Releasing to Mass Production for Uncompromised Quality
- Torque, Pull, Free fall
- Temperature Cycles with Humidity
- Vibration, ESD, Salt spray
- UV, Magnetic force, 50G ME shock
- IP ratings IPx5, IPx7, IPx8
- Common SW to capture S-parameters during production for all Taoglas Partners



## Mechanical Labs in EMEA

- LPKF routers
- Pad printing for logo
- Ultrasonic welding machines
- Komax trimmer & stripper
- Schleuniger cutters
- IPEX connector crimping machine
- Homemade manufacturing test Jigs



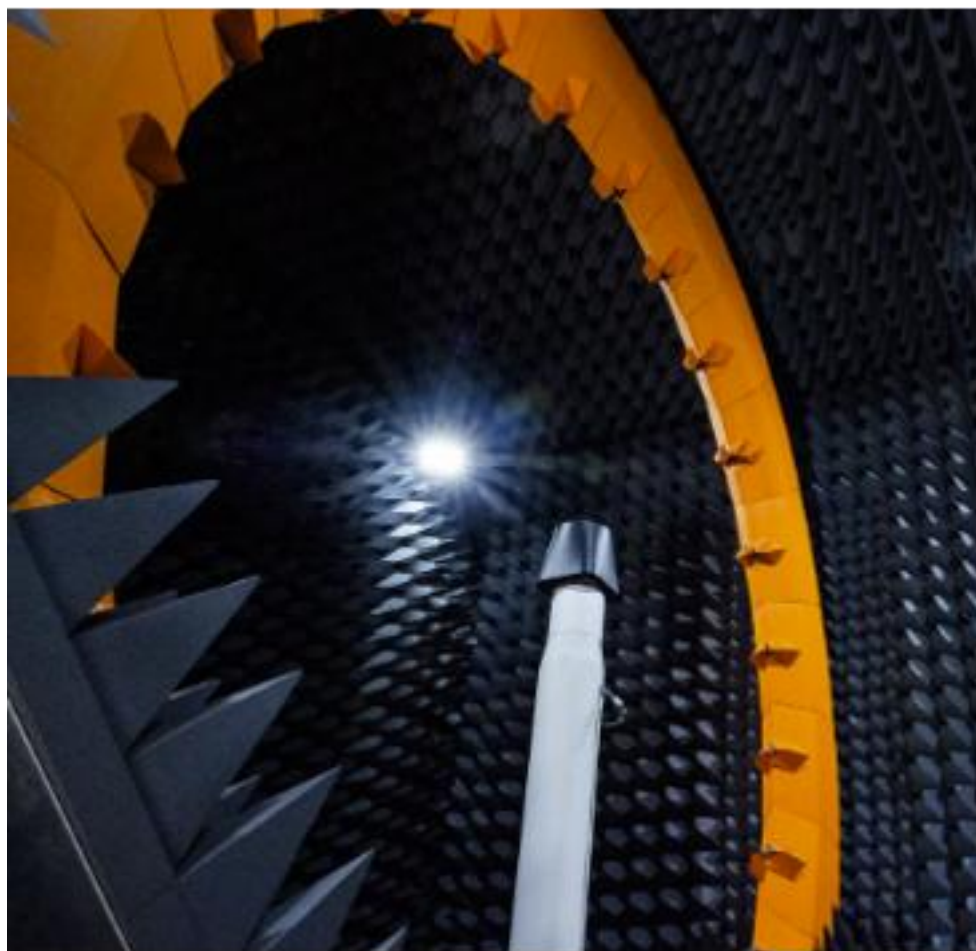
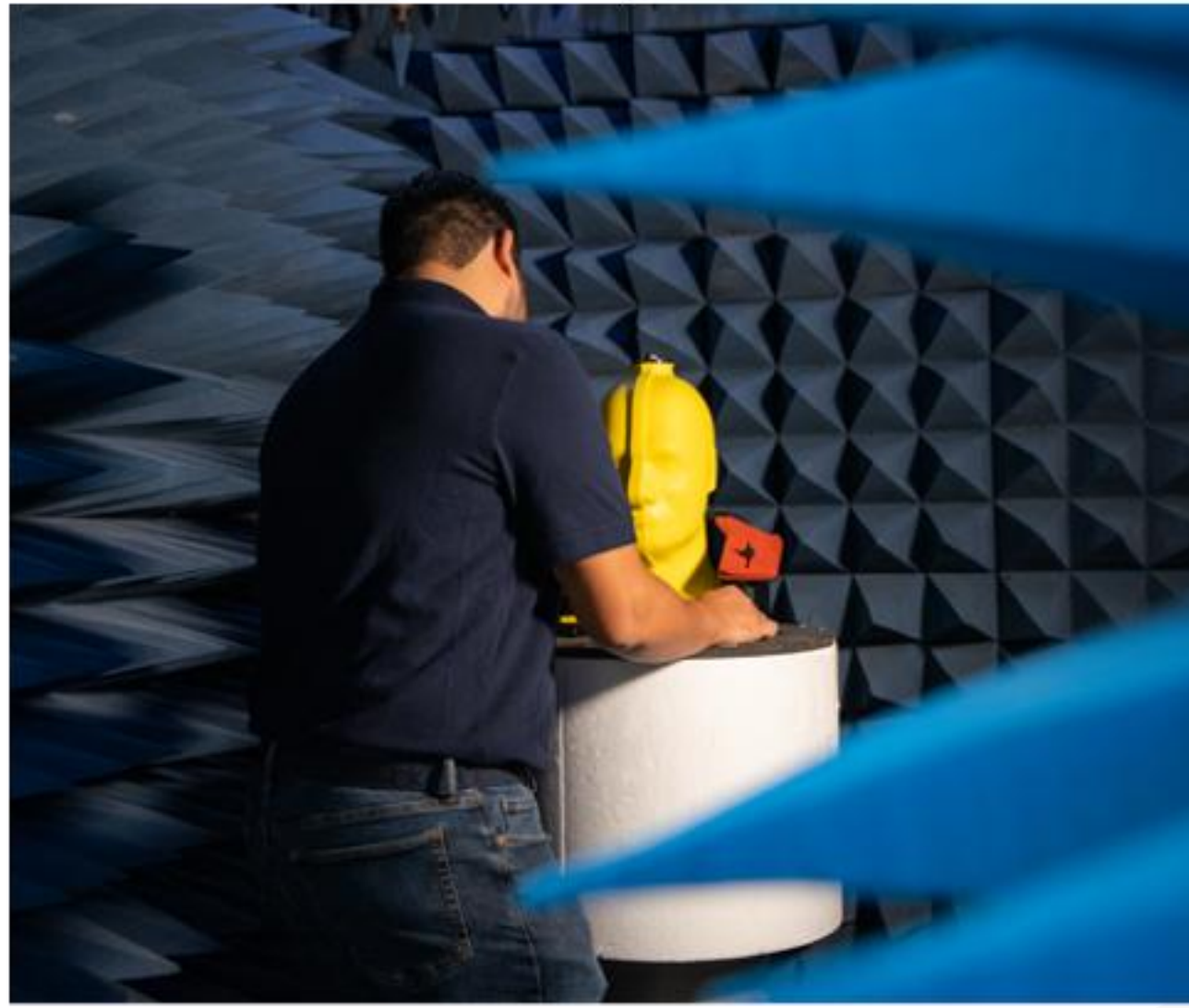

# State-of-the-Art Manufacturing Capabilities



## Global Manufacturing

- Taoglas Factory
  - Taiwan (100%)
  - India (W/H + IQC/OQC)
  - Vietnam
- Contract Manufacturers
  - Taiwan
  - Vietnam
  - India
  - Mexico

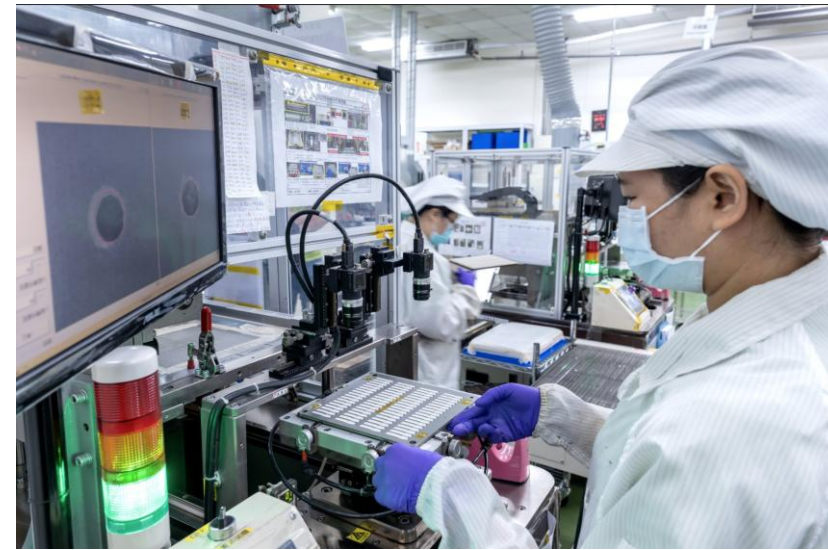

## In-house Manufacturing Capabilities

- Cable and Connector management
- Silver Paste Silk Screening on Ceramic Blocs & Terrablast
- Ultra Sonic Welding for External antennas
- Kiln Oven for ceramic baking
- Automatic welding stations
- Potting & Foaming Machines for outdoor antennas
- Water leakage machines (air pressure) for external antennas
- CNC machine
- Own Test Jig department
- Common SW to capture S-parameters during production for all Taoglas Partners



## Quality Standards

- ROHS, REACH compliance
- IATF-16949 (Factory & CM)
- ISO9001, ISO14001
- Experience with PPAP submission
- No functional field failures
  - No antenna recalls



# Delivering Long-term Quality & Trust to Rugged Transportation



**Synergy - MA1509 9-in-1**  
Combination Antenna – GNSS,  
5\*5G/4G Cellular & 3\*Wi-Fi



**Pantheon – MA750 5-in-1**  
Permanent Mount GNSS  
5G/4G 2xMIMO Wi-Fi  
2xMIMO Antenna

**Meteor FW.90**  
4G/3G/2G Cellular  
Flexible Whip,  
SMA(M)



**APEX TG.46**  
Wideband 5G/4G Dipole  
Terminal Antenna



**MagmaX2 – AA.200**  
Active Multiband GNSS  
Magnetic Mount Antenna



**SPKR.10.4.A**  
10 Inch Round Subwoofer  
Speaker 80W



**Monsoon MA170**  
2\*5G/4G MIMO Permanent  
Mount Antenna





# Lightweight, Low-profile Antennas Mobilize the Smart Battlefield

## Drone Antennas



**ADFGP.60A**  
Light weight Active  
Multi-band GNSS  
High Precision  
Patch Antenna

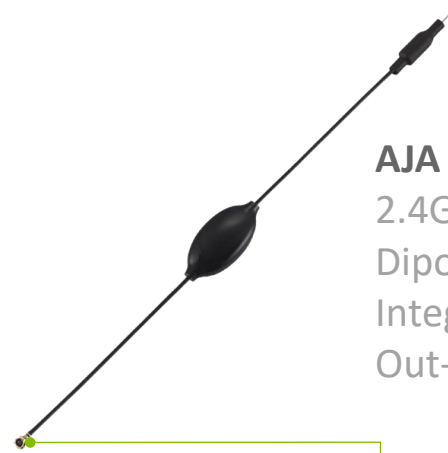

**AJA Series for UAV**  
2.4GHz Flexible Cable  
Dipole Antenna with  
Integrated Anti-Jamming  
Out-of-Band Filter



**Inception HP5354.A**  
Low Profile L1/L5 GNSS  
Patch-in-a-patch Antenna



**GP.15A**  
L1 GPS/GALILEO  
Patch Antenna

## Wearables

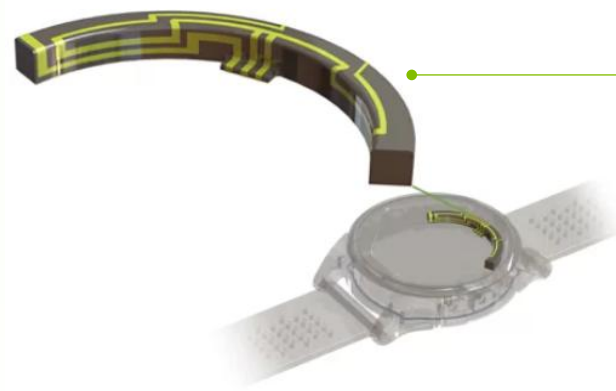

LDS technology and all other  
embedded products



**CBD Series for UAV**  
Lightweight, Thin 5.8GHz  
Cable Dipole Antenna



**ASGGB.184**  
Active GNSS Surface  
Mount Patch



**EAHP.125 for UAV**  
All-band GNSS Embedded  
Quad Helix Antenna



# Introduction to Multi-Band GNSS

The background features several abstract, overlapping geometric shapes in a lighter shade of blue, primarily located in the bottom right quadrant. These shapes include a large triangle pointing upwards and to the right, and several other angular polygons that create a sense of depth and movement.

# Multi-Constellations GNSS Systems

Use of multiple constellations results in more satellites in the field of view, which has the following benefits:



# Multi-Constellations GNSS Systems

The benefits of multi-constellation have been recognized by consumer chipset manufacturers. Currently, **more than 30% of all chipsets support four constellations.**

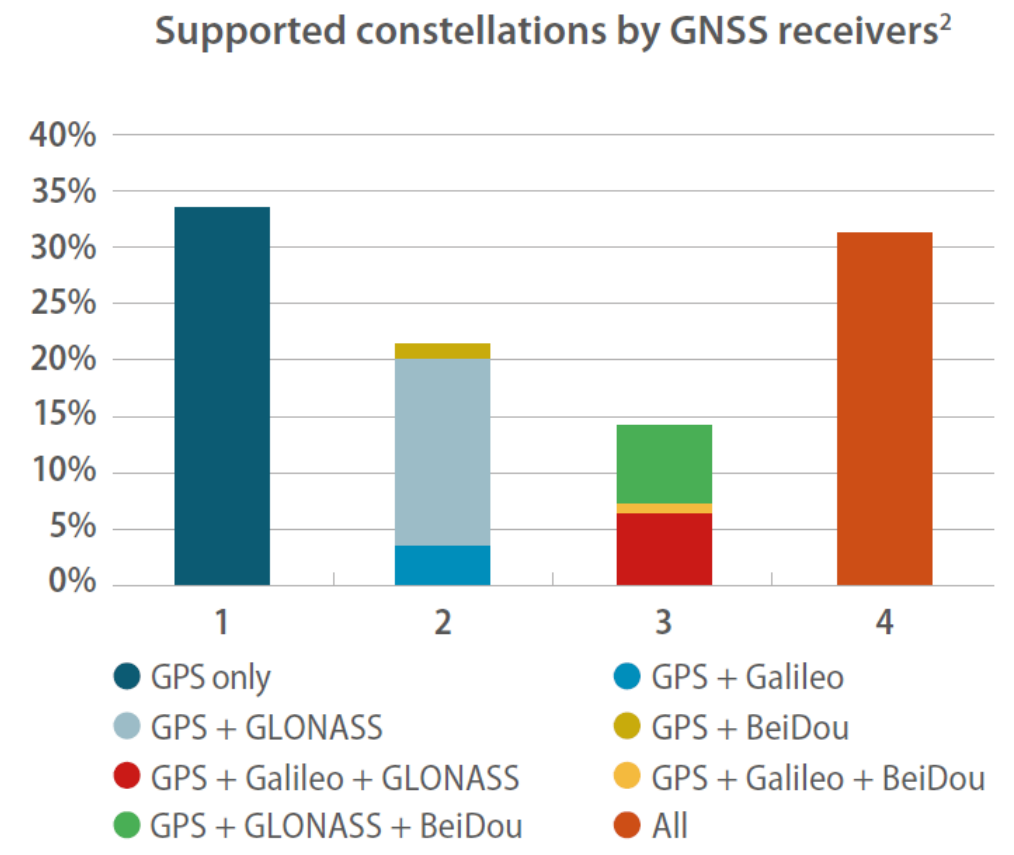
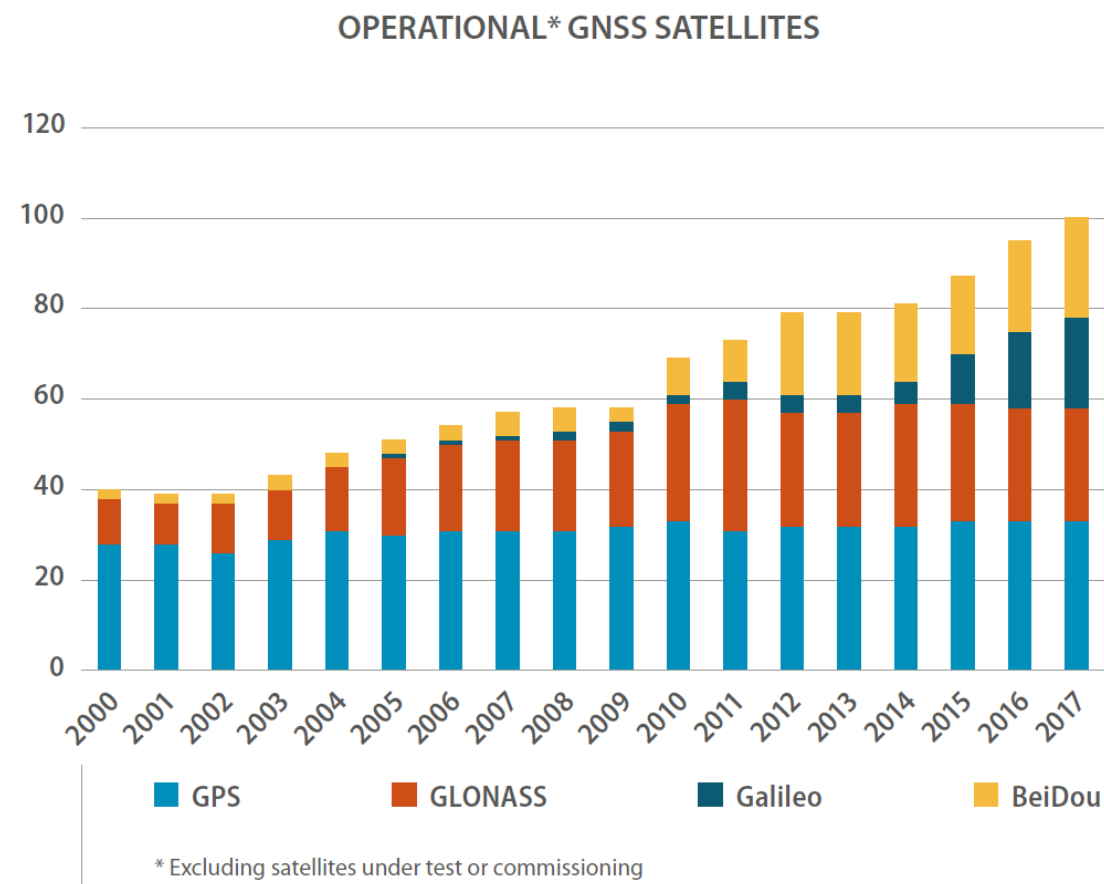

<sup>2</sup> shows the percentage of receivers capable of tracking 1, 2, 3 or all the 4 GNSS constellations

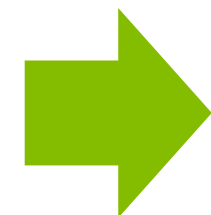

(Study European Global Navigation System Agency:  
[https://www.gsa.europa.eu/system/files/reports/market\\_report\\_issue\\_6\\_v2.pdf](https://www.gsa.europa.eu/system/files/reports/market_report_issue_6_v2.pdf))

[https://www.gsa.europa.eu/system/files/reports/gnss\\_user\\_tech\\_report\\_2018.pdf](https://www.gsa.europa.eu/system/files/reports/gnss_user_tech_report_2018.pdf)



# GNSS Technology 101 – US **Global Positioning System (GPS)** Example

GPS Bands	L1	L1 + L2	L1 + L5	L1 + L2 + L5	L1 + L2 + L5 + L-band	RTK
Basic Info	Legacy configuration	Common configuration	Long-term configuration	Future-proof global solution	Supports correction service	All-in-one solution
Accuracy	3m	1.5m	1.5m	1.5m	0.2m	cm-level
Power			Improved gain	Improved gain + more resilience, dynamic movement, signal more often		

## L1

1575.42 MHz

- Legacy configuration in ALL satellites
- Civilian signals

## L2

1227.60 MHz

- Legacy configuration in ALL satellites
- Signal not as good → lower power and narrower signal
- Military signals

## L5

1176.45 MHz

- Provided in NEWER satellites
- Higher gain signal → more power from L5 than L1
- L1/L5 is more resilient, better stability/accuracy
- Civilian signals

## L-band

1542 MHz

- Subscription-based corrections (PPP) from satellite
- Provides higher level of accuracy

## E6

1278.75 MHz

- Free correction service in GALILEO E6 satellites *not yet turned on*
- Provides higher level of accuracy



# Multi-band Solutions are Bigger...



Single band, quad constellation  
25\*25\*4mm



Triple-band, quad constellation  
50\*50\*12mm



All-band, quad feed  
Ø80\*19.1mm

...and more complex

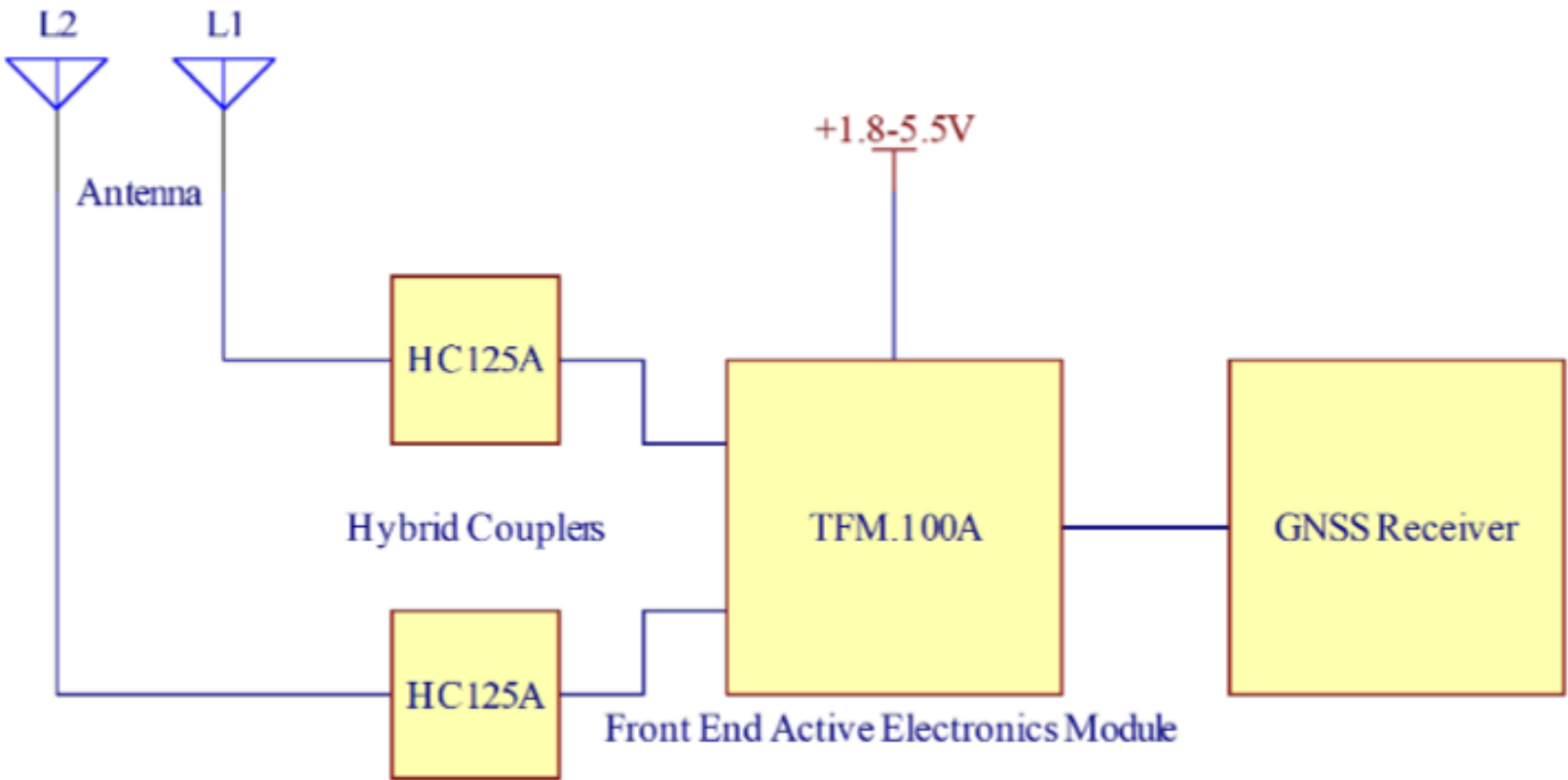

Block Diagram of integration of the TFM.100A



# Future-proof your GNSS design with Taoglas Antenna solutions

- For years designs have been using single band GNSS → same antennas, same filters & amplifiers.
  - Typical design has a 25x25x4mm patch antenna, or an active antenna for off board, or an external antenna
- Today - new bands and technology (L2, L5, L6, L-band) - means you can enjoy cleaner signal and better accuracy
- Prices are coming down for technology around the new bands, e.g. Radio Modules

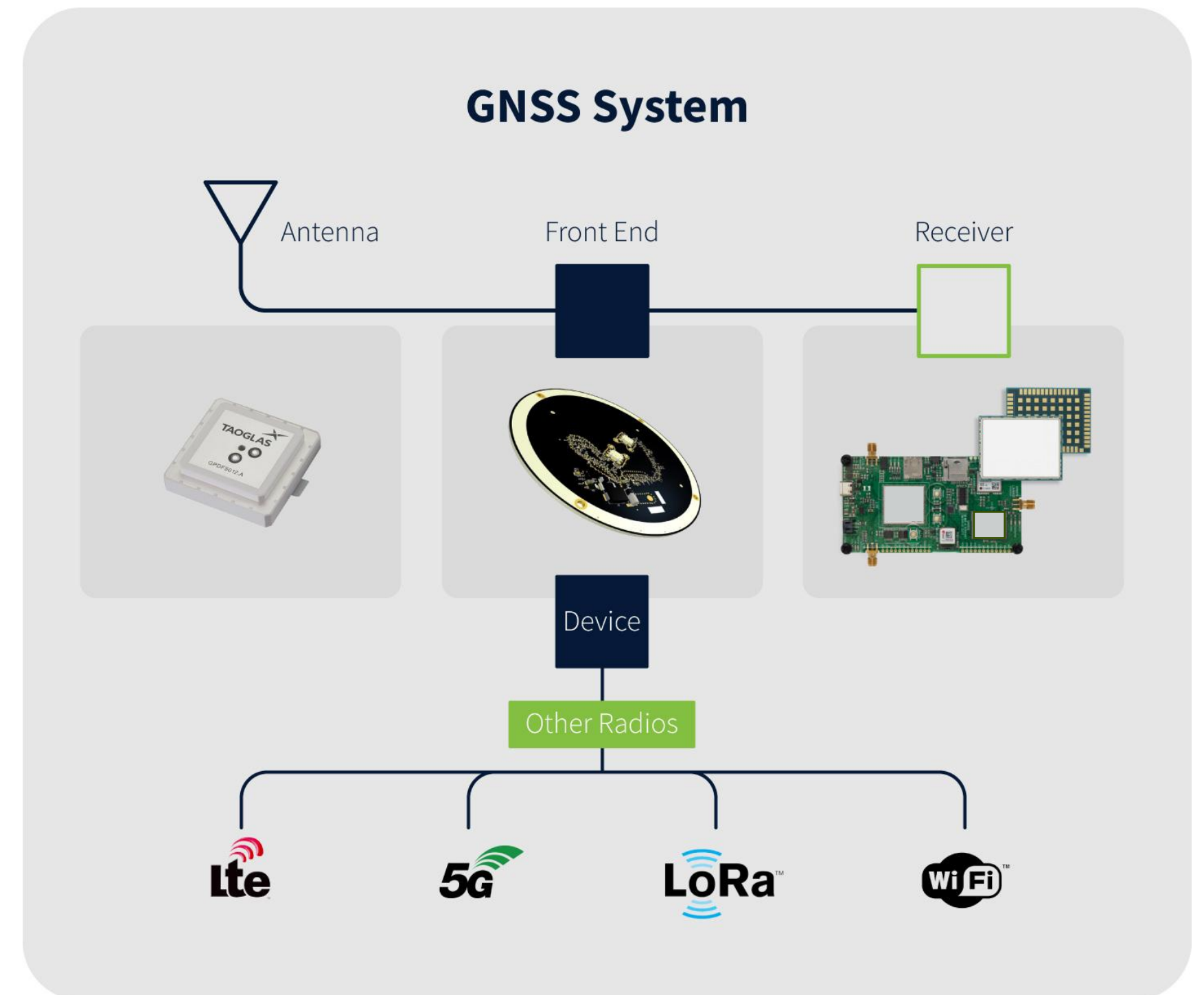

# GNSS Antenna Types

## Chip

### Loop Antenna

#### Characteristics:

- Linear Polarized Antennas (catch half of the signal)
- Small Antennas
- Passive or Active Antennas



GGBLA.125A

## FPC

### Flexible PCB

#### Characteristics:

- Linear Polarized Antennas
- Variety of sizes
- Omnidirectional
- Passive or Active Antennas



FXP612

## Patch

### Passive or Active

#### Characteristics:

- RHCP Polarized Antennas
- Large variety of sizes
- High Gain
- Passive or Active Antennas

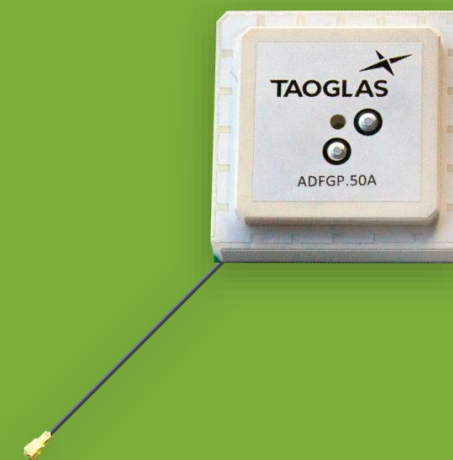

ADFGP.50

## Dipole

### Cross-Dipole

#### Characteristics:

- RHCP Polarized Antennas
- Low Cross-Pol
- Wide bandwidth
- Passive or Active Antennas



EAHP.60

## Helical

### Quad Helical

#### Characteristics:

- RHCP Polarized Antennas
- Large variety of sizes
- Omnidirectional
- Passive or Active Antennas



EAHP.125

Size / Cost / Performance



# Mounting Types

## Terminal Mount



TS.07 Monopole Terminal Antenna

## Adhesive Mount



STINGRAY Adhesive Mount Antenna

## Screw Mount



Colosseum Screw / Permanent Mount

## Magnetic Mount



MAGMA Magnetic Mount

## Wall Mount



GUARDIAN Wall Mount

## Pole Mount



THUNDER Pole Mount



# GNSS Antenna Characteristics

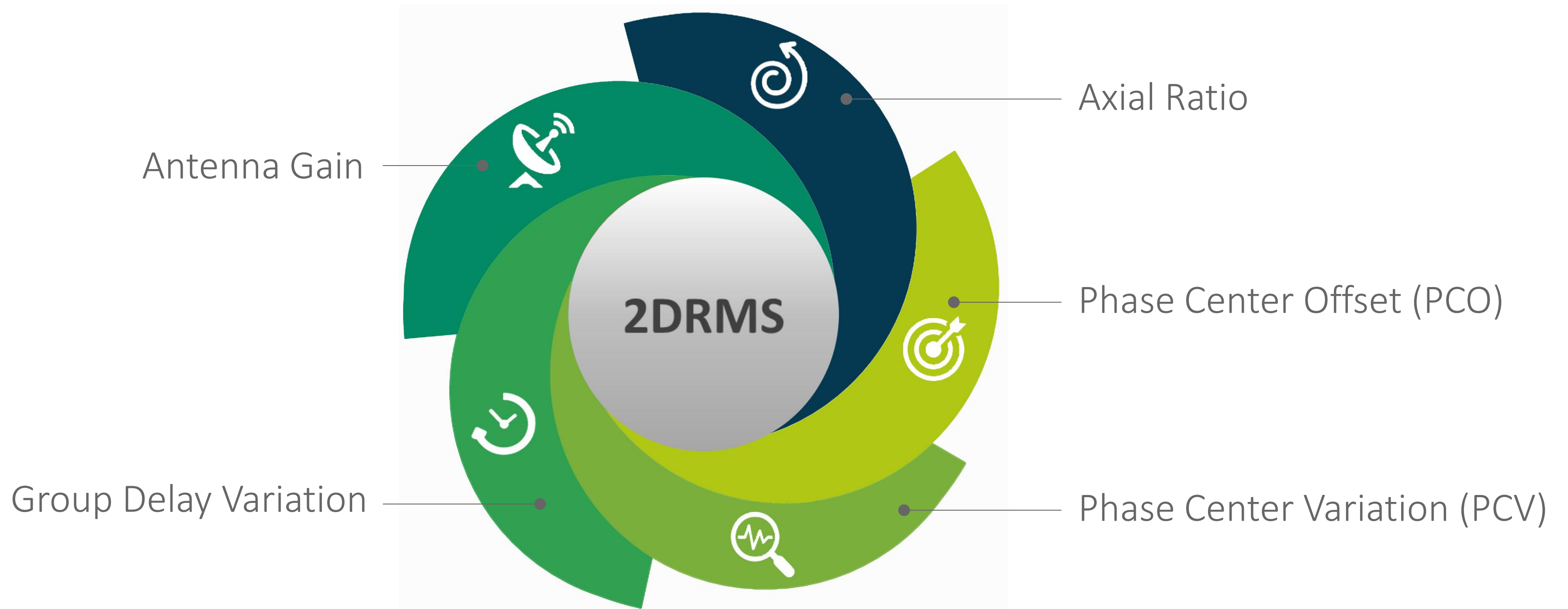

Twice of the Distance Root Mean Squared (2DRMS) is a single number that illustrates two-dimensional accuracy. It is the probability of being within a circle, with a radius equals to 2DRMS, 95% of the time.



# Types of GNSS Antennas

GNSS Antennas

## Passive or Active?

Application Design Priorities as an Indicator

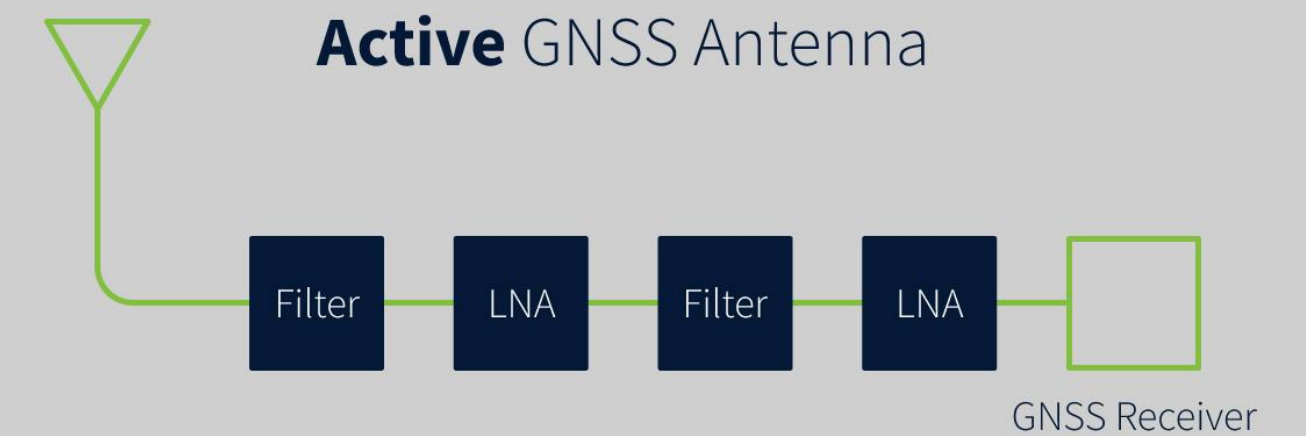
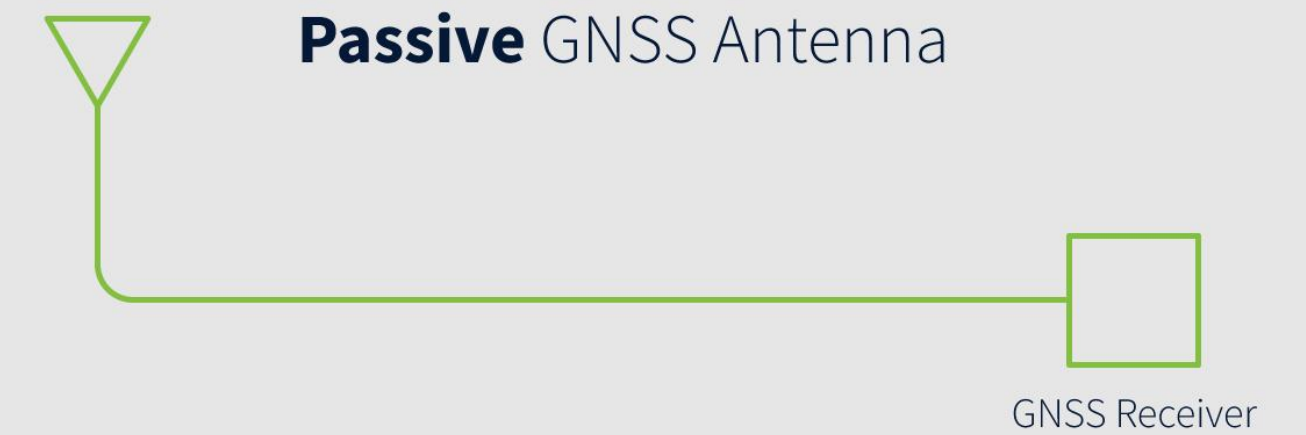
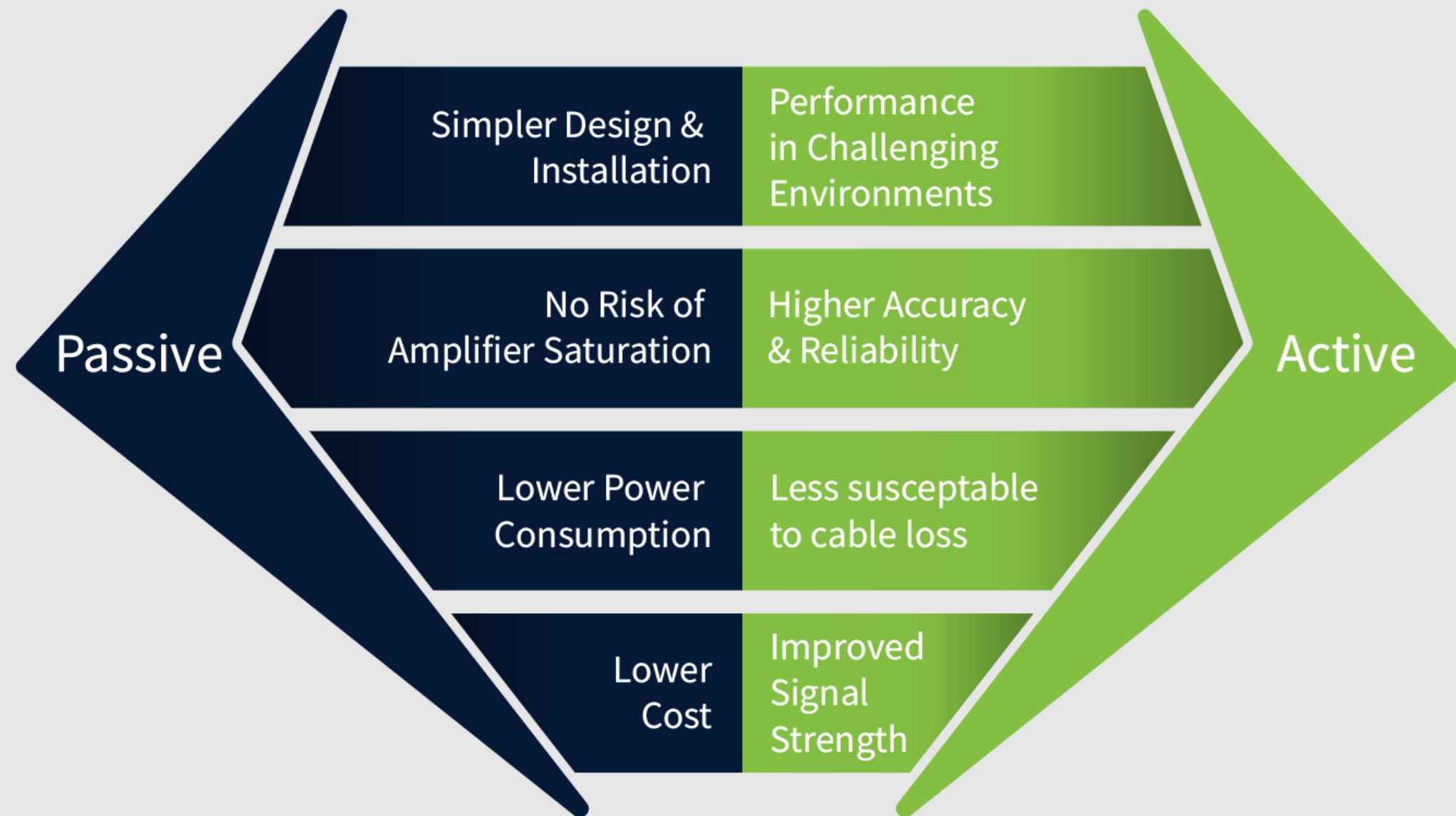

# Taoglas Product Portfolio

The image features a dark blue background with the text 'Taoglas Product Portfolio' in white. In the bottom right corner, there are several overlapping, semi-transparent geometric shapes in a slightly lighter shade of blue, including triangles and polygons, creating a modern, abstract design.

# Longstanding History of Taoglas External Antenna Designs



**SYNERGY** Combo up to 11-in-1



**OLYMPIAN II** Combo up to 3-in-1



**GUARDIAN** Combo up to 9-in-1



**GUARDIAN X** Combo up to 17-in-1



**HERCULES** GNSS 2-in-1



**ULTIMA**



**SENTINEL** Combo up to 3-in-1



**STREAM** Combo up to 3-in-1



**PANTHEON** Combo up to 5-in-1



**STORM** Combo up to 5-in-1



**COLOSSEUM** Combo up to 5-in-1



**RAPTOR III** Combo up to 7-in-1



**20+ Years Trusted Quality and Innovation**

# Longstanding History of Taoglas **External Antenna** Designs



**Raptor X** Combo up to 5-in-1



**COMET** 3-in-1 GNSS



**TGX.04** 4 x 5G/4G LTE MIMO



**NEPTUNE** Multi-Band Active GNSS Multi-Mount Marine

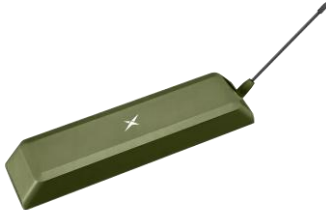

**Raptor MAX** Combo up to 12-in-1



**MA343** Combo up to 3-in-1



**MAGMA X** GNSS L1/L2/L5/L-Band Series



**CAMPTENNA** Combo 3-in-1



**SYNERGY X**



**TGX.08** MIMO 8-in-1









**LMA** MIMO Antenna

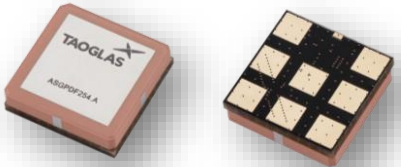
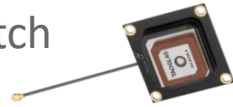
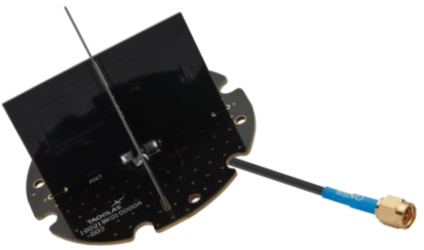
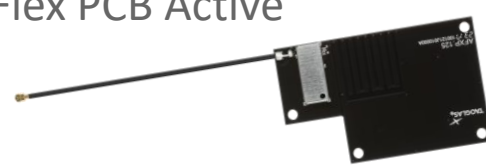

**TS.125** Multi-Band (+ L Band) GNSS Antenna

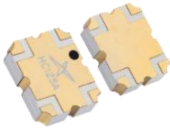

# High Precision **Embedded GNSS** Antenna & Components Portfolio – Featured Products

GPS Bands	L1	L1 + L2	L1 + L5	L1 + L2 + L5	L1 + L2 + L5 + L-band
Embedded Antennas - Active	<b>ASGPDF254</b> Dual Feed SMD Active Patch 	<b>AGPSF.36C</b> GPS L1/L2 Low Profile Stacked Patch 	<b>AGVLB.25B</b> Stacked Patch 	<b>EAHP.50</b> – L1/L2/L5/L6 Cross Dipole 	<b>AHP24510</b> L1/L2/L-Band 
			<b>AFXP125</b> Flex PCB Active 		<b>ALPDF254</b> L-Band Patch 
			<b>AGGBLA.125</b> Active SMD 		<b>ADFGP.50A</b> – L1/L2/L5 Dual-feed Stacked Patch 
Embedded Antennas – Passive	<b>SGPDF254</b> Dual Feed SMD Patch 	<b>HP2258.A</b> Stacked Patch 	<b>HP5354.A</b> Patch-in-a-patch 		<b>HP24510A</b> Dual-feed L1/L2/L-band Stacked Patch 
					<b>HP54510A</b> Dual-feed L1/L5/L-band Stacked Patch 
Active Circuitry – Front End Modules		<b>TFM.100A</b> FEM 	<b>TFM.100B</b> FEM 	<b>TFM.110A</b> FEM 	<b>TFM.120A</b> FEM 
Hybrid Couplers	<b>HC125A</b> – Low Profile 				



# What's your **biggest challenge** and how can we help?

## Cutting-edge Applications

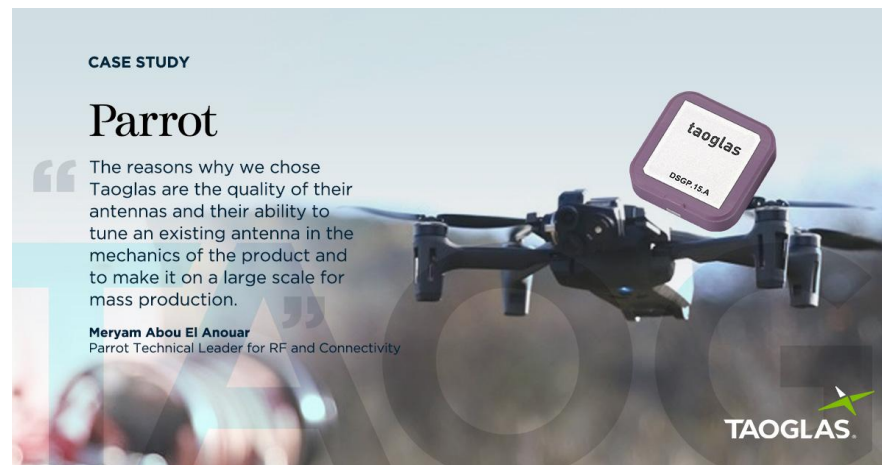

### Innovative Antenna Designs for:

- Public Safety & Humvee (rooftop antenna)
- Smart Battlefield (tablets)
- Wearables for soldiers
- Aerospace / Satcom
- UAVs, Drones (lightweight terrablast antennas)

[Pantheon Antennas Keep Sparks Police Department Reliably Connected](#)  
[Taoglas GNSS antenna flies with Parrot drones](#)

## Customer Success Stories

### Fotokite Drone Case Study

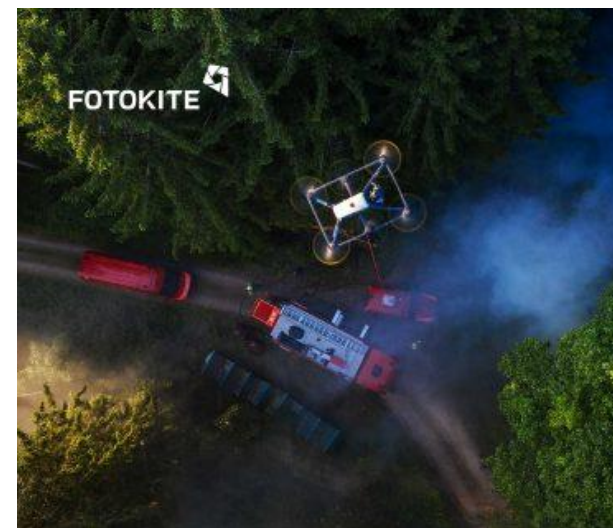

### The Challenge

During their initial tests, the Fotokite team discovered that the antennas used in their solution had significant Wi-Fi coverage issues. Additionally, with the space already at a premium, another two separate antennas for GPS (Global Positioning System) and LTE coverage were positioned incorrectly – leading to significant interference, signal loss and overall loss of antenna performance.

[Taoglas antenna takes flight with Fotokite's tethered drone](#)

## Webinars & Videos

### EIRSAT-1 Video



<https://www.taoglas.com/case-study/eirsat-1-irelands-first-satellite/>

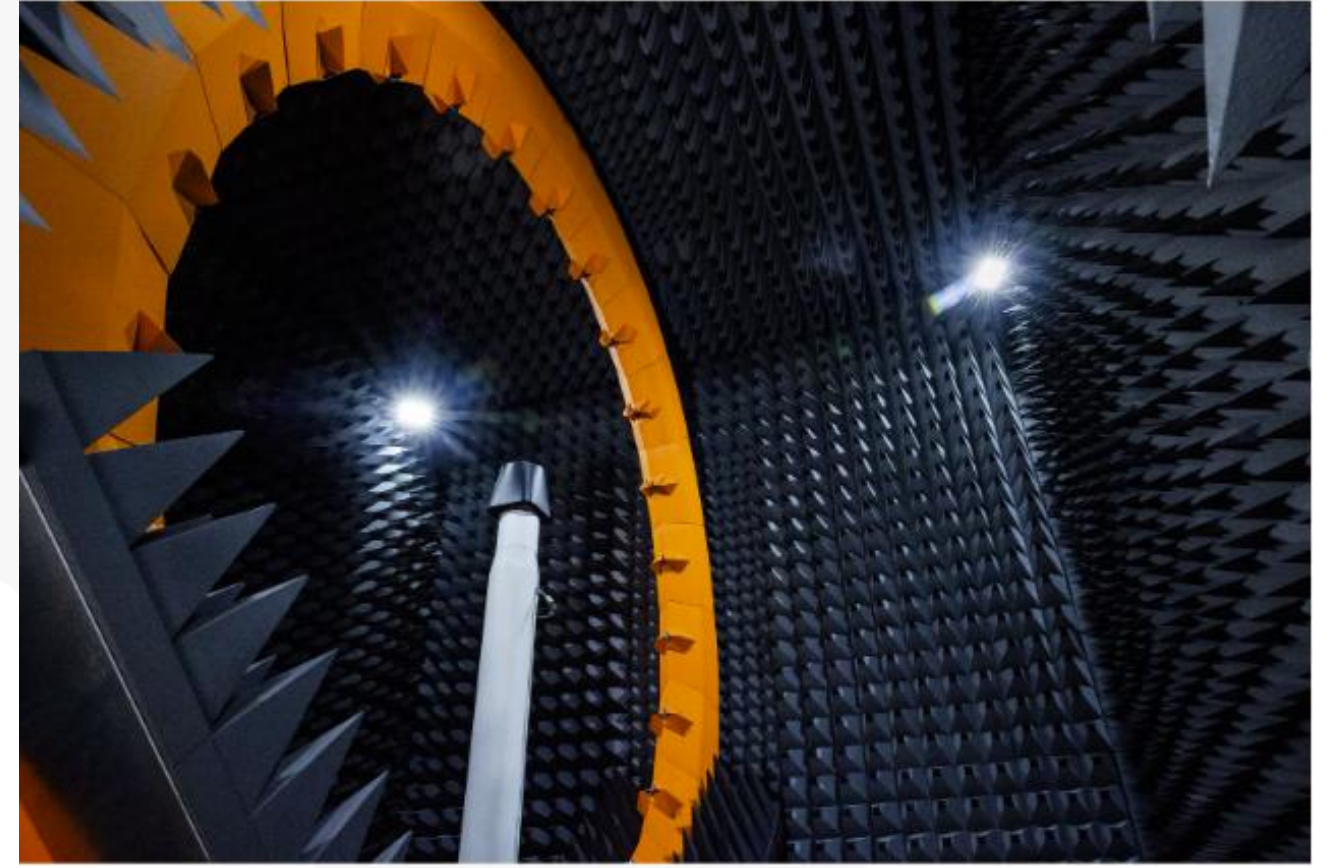



# Questions?

Please utilize the private Q&A function within the chat box.

# Contact Us

**Samuel McCarthy**  
VP of EMEA Sales

E: [smccarthy@taoglas.com](mailto:smccarthy@taoglas.com)  
M: +33 7 83 48 97 16  
[www.Taoglas.com](http://www.Taoglas.com)



# Useful Links

## GNSS Antenna Portfolio:

- [GNSS Embedded Antennas, GNSS Antennas, Embedded Antennas](#)
- [GNSS External Antennas, GPS Antennas, External Antennas](#)

## AntennaXpert Tool Suite:

- [Antenna Integrator - Taoglas](#) (Powered by AI)
- [Antenna Builder Tool : Build Your Custom Antenna - Taoglas](#)
- [Cable Builder Tool : Build Your Custom Cable - Taoglas](#)

## Information on antenna integration and selection services:

- [CSA-10: Antenna Feasibility Study](#)

## GNSS Information Hub:

- [GNSS Technology Overview: Evolution, Applications, and Antennas](#)

## Blogs:

- [Dual-Band vs. Multi-Band GNSS Antennas: Key Factors to Consider](#)
- [How GNSS Antennas Help Thwart Jamming Attacks | Taoglas](#)
- [GNSS Antenna Integration: Best Practices](#)





# TAOGLAS

Engineering Global Connectivity With You

[www.taoglas.com](http://www.taoglas.com)

